

# UTILITY VEHICLE E-GATOR™

Serial No. (001001– )

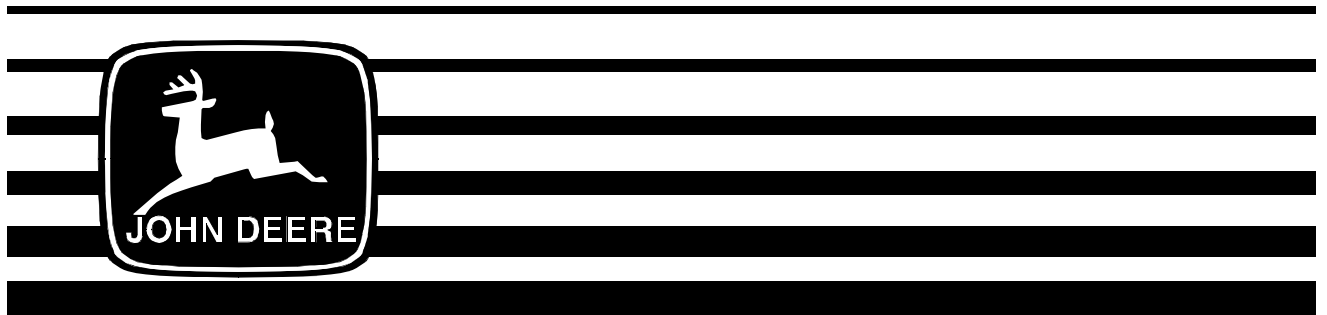

# OPERATOR'S MANUAL

John Deere  
Worldwide Commercial And  
Consumer Equipment Division  
OMM135735 E9

North American Version  
Litho in U.S.A.

English

# INTRODUCTION

---

**THANK YOU** for purchasing a John Deere product.

Read this manual thoroughly. Failure to do so could result in personal injury or equipment damage.

This manual should be considered a permanent part of your machine and should remain with the machine when you sell it.

Measurements in this manual are metric units and their U.S. customary equivalents. RIGHT-HAND and LEFT-HAND sides are determined by facing in the direction the machine will travel when going forward. When you see a broken line arrow (---->), it indicates the part it is pointing to is hidden.

Record identification numbers below. Be sure to record all the numbers to help in tracing the machine if it is stolen. You also need to give these numbers to your dealer when you order parts.

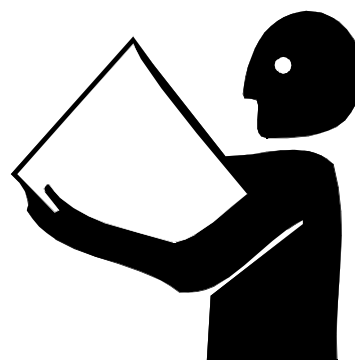

**DATE OF PURCHASE:**

\_\_\_\_\_

**DEALER NAME:**

\_\_\_\_\_

**DEALER PHONE:**

\_\_\_\_\_

**PRODUCT IDENTIFICATION NUMBER (A):**

-----

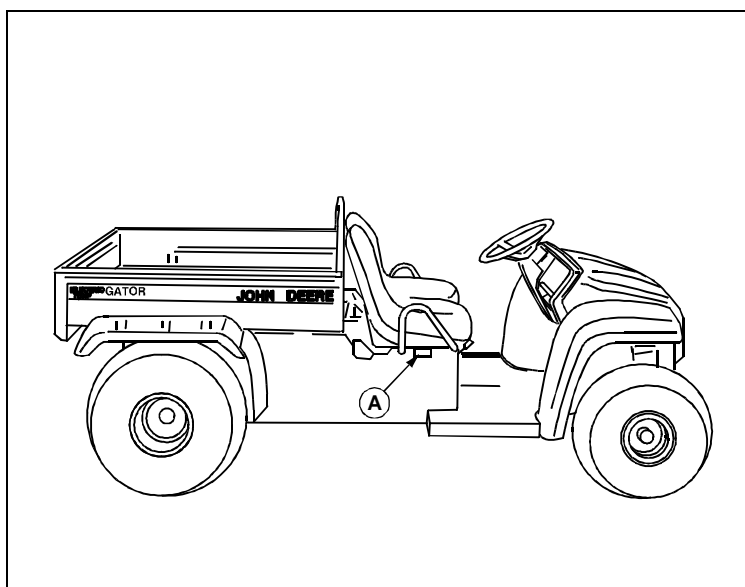

---

---

# TABLE OF CONTENTS

---

---

|   |     |
|---|-----|
| Safety Signs . . . . .                  | 1   |
| Controls . . . . .                      | 7   |
| Operating . . . . .                     | 9   |
| Replacement Parts . . . . .             | 43  |
| Service Machine Safely . . . . .        | 44  |
| Service Interval Chart . . . . .        | 50  |
| Service -Battery . . . . .              | 52  |
| Service -Electrical . . . . .           | 78  |
| Service - Miscellaneous . . . . .       | 81  |
| Troubleshooting . . . . .               | 86  |
| Storing Machine . . . . .               | 88  |
| Assembly . . . . .                      | 92  |
| Specifications . . . . .                | 104 |
| Warranty . . . . .                      | 114 |
| Index . . . . .                         | 115 |
| John Deere Service Literature . . . . . | 119 |

All information, illustrations and specifications in this manual are based on the latest information at the time of publication. The right is reserved to make changes at any time without notice.

COPYRIGHT© 1999  
Deere & Co.  
John Deere Worldwide Commercial and  
Consumer Equipment Division  
Horicon, WI  
All rights reserved

OMM135735 E9

**<https://www.ebooklibonline.com>**

Hello dear friend!

Thank you very much for reading.

Enter the link into your browser.

The full manual is available for immediate download.

**<https://www.ebooklibonline.com>**

# SAFETY SIGNS

## Safety-Alert Symbol

Read and recognize safety information. Be alert to the potential for personal injury when you see this safety-alert symbol.

On your machine safety labels, the words DANGER, WARNING, and CAUTION are used with this safety-alert symbol. DANGER identifies the most serious hazards. In this manual, the word CAUTION and this symbol call attention to safety messages.

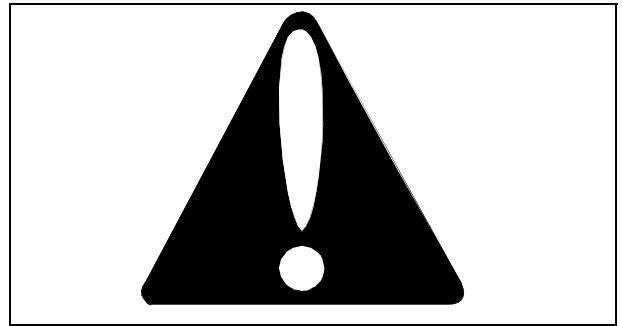

## Machine Safety Labels

### WARNING

#### RIDERS CAN FALL OFF AND BE KILLED

- Maximum of one person to a seat.
- No riders in box or anywhere else.

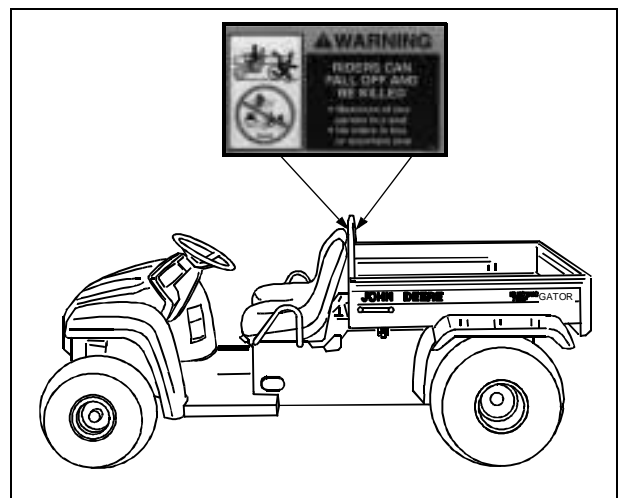

### DANGER

#### To avoid injury from electrical burns or battery explosion

- Read the operator's manual.
- Turn key off, place FORWARD/REVERSE lever to Neutral (N) and remove key.
- Place SERVICE switch in SERVICE position.
- Never disconnect a circuit under load at a battery terminal.
- Remove all jewelry (rings, watches etc.).
- Use insulated tools only.
- Disconnect batteries, as shown, to avoid unintentional starting of vehicle. Pay close attention to polarities when connecting batteries. Always connect the red end of the cable to the positive (+) post and the black end of the cable to the negative (-) post.

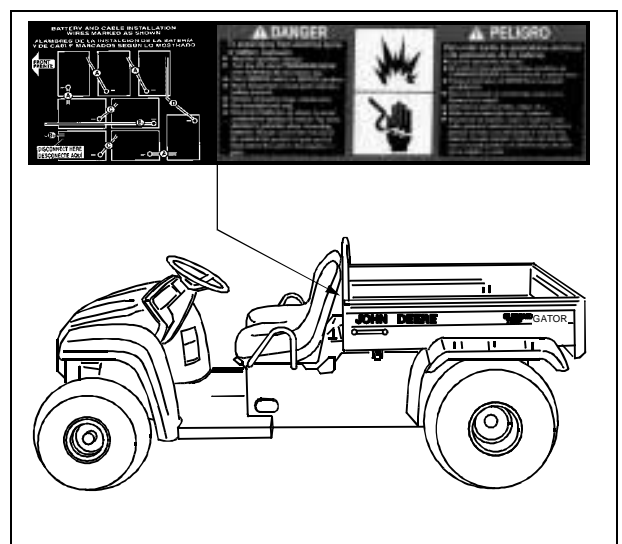

## SAFETY SIGNS

### WARNING

#### YOUNG DRIVERS INCREASE CHANCE OF DEATH

- Young drivers may not be able to control vehicle.
- No drivers younger than 16 years old.

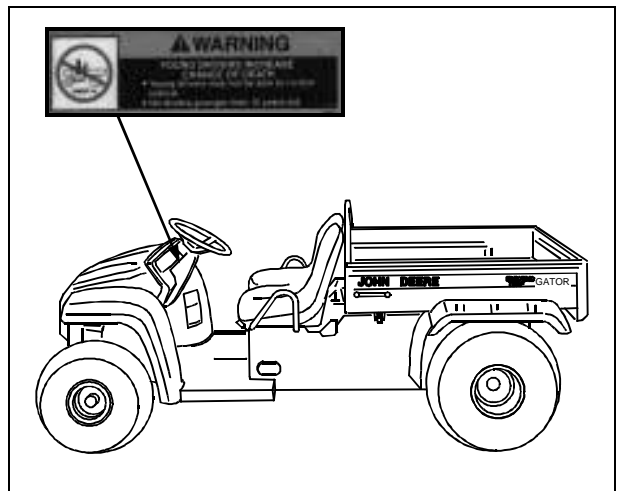

### WARNING

#### ROLLOVER OR FALLING OFF MAY CAUSE DEATH

- Read operator's manual.
- Drive very slowly when turning.
- Always use brakes going down a slope. Vehicle can take-off (freewheel) downhill.
- No loads heavier than 500 lbs (227 kg) in 4x2. Spread load evenly. Tie loads down.
- Reduce speed and load on rough or hilly ground.

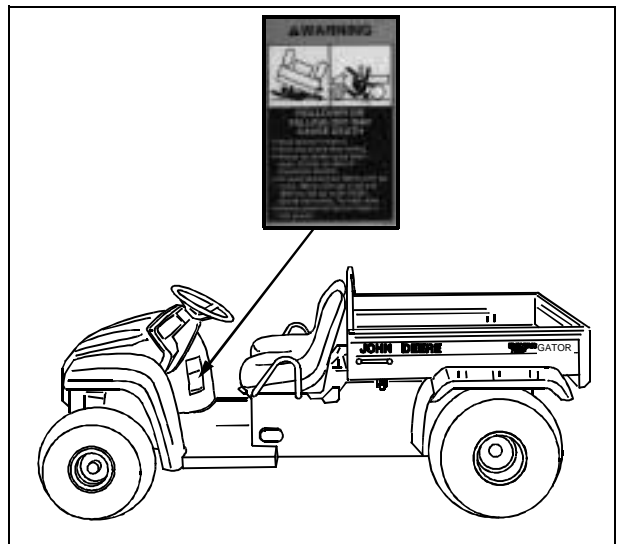

### CAUTION

#### Before leaving vehicle:

- Shift to neutral.
- Set park brake.
- Remove key.

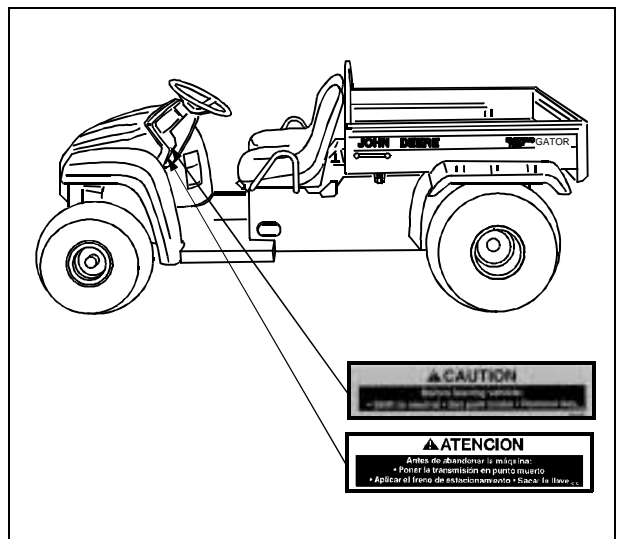

# SAFETY SIGNS

## DANGER/POISON

**Picture Note:** Raise cargo box to locate battery safety information. English DANGER/POISON information (A) molded into battery caps. Spanish DANGER/POISON labels (B) are located on each vehicle frame side rail.

## Explosive Gases

Cigarettes, flames or sparks could cause the batteries to explode. Always shield eyes and face from the batteries. Do not charge or use booster cables or adjust poor connections without proper instruction and training. Keep vent caps tight and level.

## Causes Severe Burns

Contains sulfuric acid. Avoid contact with skin, eyes or clothing. In event of an accident, flush with water and call a physician immediately. Keep out of reach of children.

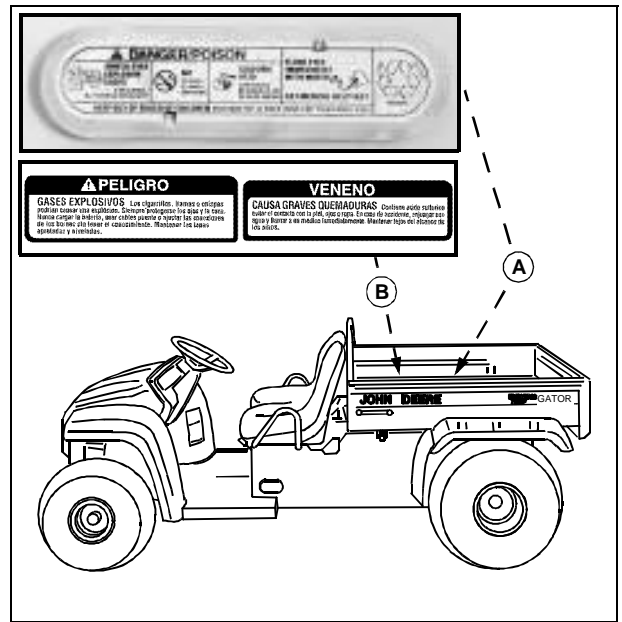

## DANGER

### To avoid injury from batteries and motor exploding or electrical arcing/shock:

**Picture Note:** Lift operator seat to locate safety labels.

Place switch in SERVICE position before servicing batteries or when towing.

Do not tow in excess of 15 m.p.h. (24 km/h) or motor may rupture or disintegrate.

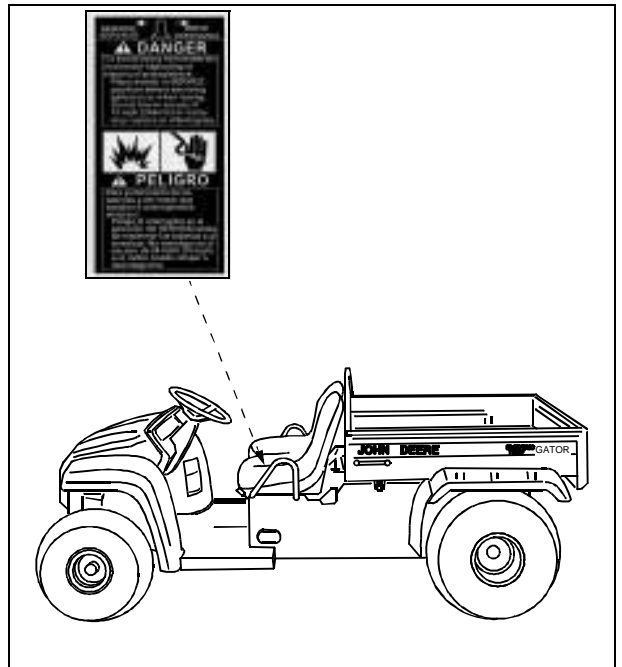

# SAFETY SIGNS

## CAUTION

### HELP PREVENT INJURY WHEN DUMPING LOADS

**Picture Note:** Safety label attached to cargo box load guard when equipped with the power lift option.

- Operate dump with machine stationary and parking brake locked: Never dump while moving.
- Operate dump on level ground only.
- Operate dump from operator's seat only.
- Do not place hands behind seat when lowering box.
- Refer to operator's manual for correct load distribution.

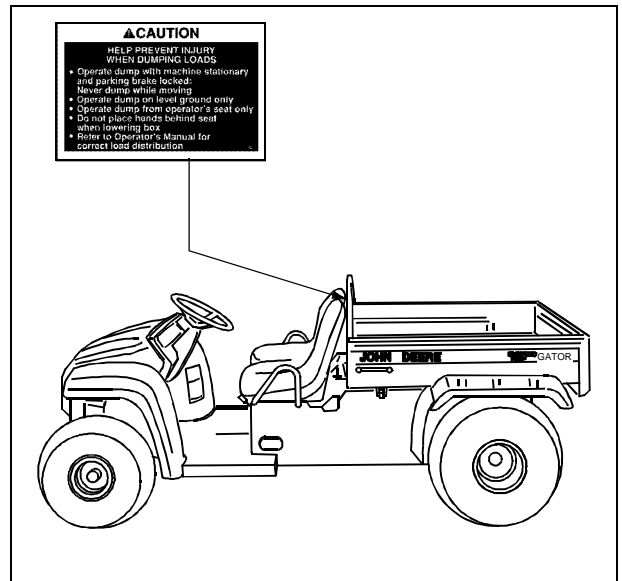

## Battery Charger Safety Labels

### CAUTION

**Engage connector fully for proper charging.**

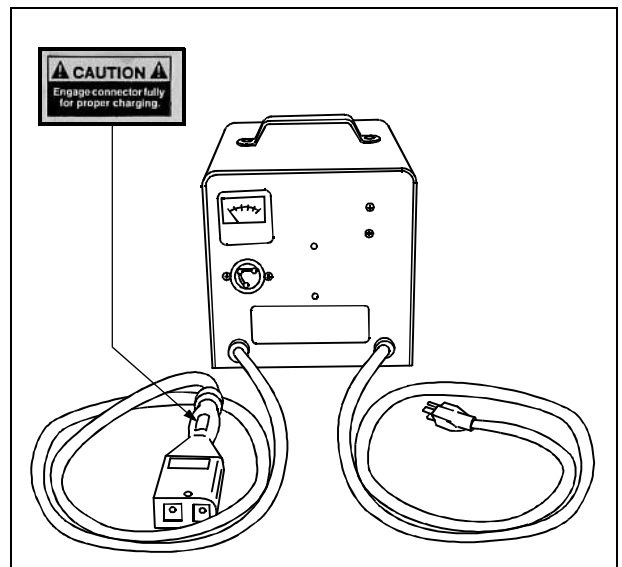

## SAFETY SIGNS

### WARNING

**Picture Note: Battery charger WARNING information inscribed on top of battery charger housing.**

- TO REDUCE THE RISK OF FIRE, DO NOT USE CHARGER NEAR FLAMMABLE MATERIALS OR VAPORS! BATTERIES GENERATE EXPLOSIVE GASSES DURING OPERATION. KEEP SPARKS AND FLAME AWAY FROM BATTERIES! NO SMOKING!
- MAKE SURE DC OUTPUT CHARGING PLUG AND RECEPTACLE ARE IN GOOD CONDITION! DO NOT USE IF DC PLUG OR RECEPTACLE ARE DAMAGED, LOOSE, OR FEEL HOTTER THAN NORMAL! REPLACE WORN OR DAMAGED PARTS IMMEDIATELY!
- DO NOT DISCONNECT THE CHARGER OUTPUT CONNECTOR FROM THE BATTERY CONNECTOR WHEN THE CHARGER IS ON. THE RESULTING ARCING AND BURNING WILL DAMAGE THE CONNECTORS AND COULD CAUSE THE BATTERIES TO EXPLODE. DISCONNECT INPUT CORD TO TURN CHARGER OFF.
- TO AVOID DAMAGE TO OUTPUT CORD, PLUG AND BATTERY RECEPTACLE, DO NOT PULL ON OUTPUT CORD! DO NOT TWIST, ROCK OR BEND PLUG SIDEWAYS!

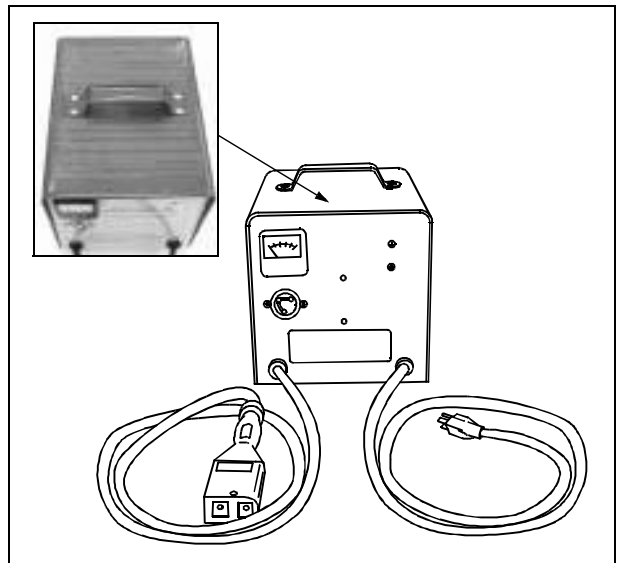

### DANGER

**Picture Note: Battery charger DANGER information inscribed on top of battery charger housing.**

- ELECTRICAL SHOCK HAZARD! DO NOT TOUCH UNINSULATED PORTION OF OUTPUT CONNECTOR OR UNINSULATED BATTERY TERMINALS!

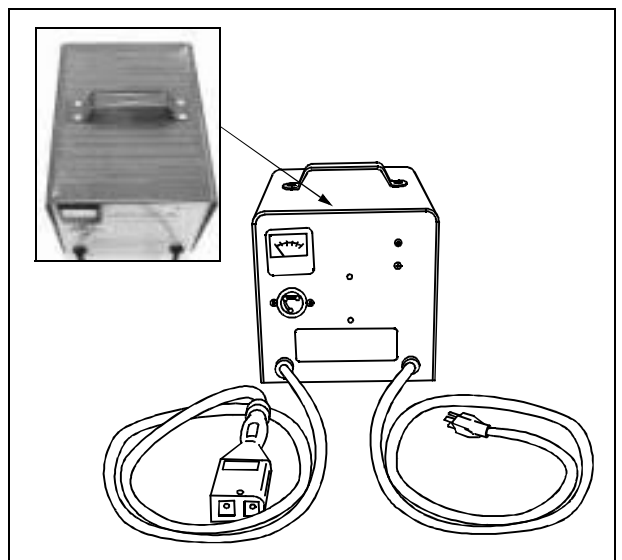

## SAFETY SIGNS

### CAUTION

**Picture Note: Battery charger CAUTION information inscribed on top of battery charger housing.**

- OUTPUT LEAD DC POLARITY: POSITIVE; "+", RED. NEGATIVE; "-", BLACK AND BLUE.
- TO REDUCE THE RISK OF ELECTRIC SHOCK, CONNECT ONLY TO PROPERLY GROUNDED THREE WIRE OUTLETS! DO NOT EXPOSE TO RAIN, POWER WASH DETERGENTS, OR SPRAY!
- USE ONLY ON CIRCUITS PROVIDED WITH A MAXIMUM OF 15 AMP BRANCH CIRCUIT PROTECTION IN ACCORDANCE WITH THE NATIONAL ELECTRIC CODE ANSI/NFPA 70 AND ALL LOCAL CODES AND ORDINANCES! IMPROPER CIRCUIT PROTECTION MAY RESULT IN A FIRE.
- USE ONLY ON 48 VOLT, 24 CELL (2.5 VOLTS PER CELL) WET LEAD ACID SYSTEM OF 140 TO 270 AH (20 HOUR RATE)! OTHER TYPES OF BATTERIES MAY BURST CAUSING PERSONAL INJURY AND DAMAGE!

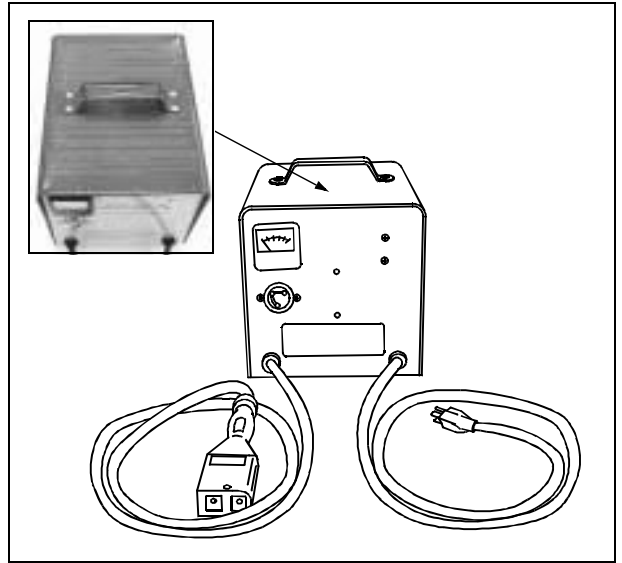

# CONTROLS

## Dash Controls

- A - Cargo Box Dump Switch (Option)
- B - Key Switch
- C - Headlight Switch
- D - Charge Meter / Hour Meter (Option)



## Foot/Platform Controls

- A - Foot Brake Pedal
- B - Accelerator Pedal
- C - Park Brake Lever
- D - Directional Control Lever

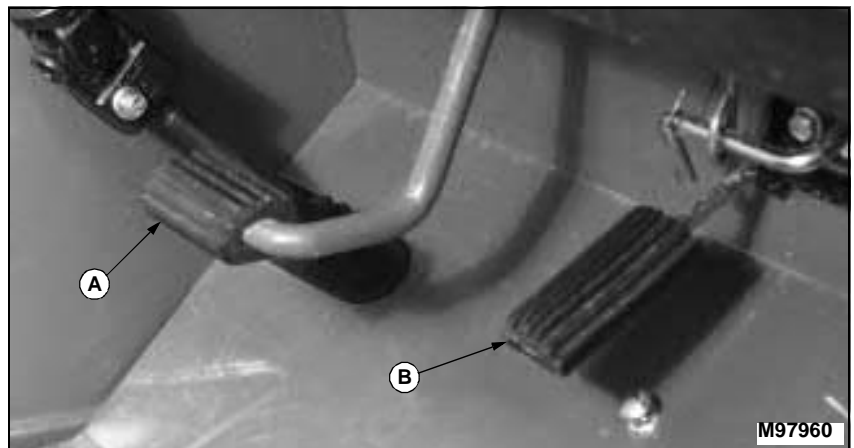

# CONTROLS

## Miscellaneous Controls

Picture Note: Raise operator seat to locate service/drive switch.

A - Service/Drive Switch



# OPERATING

---

## Operate Safely

- View the videotape provided with the vehicle for safe operating practices.
- DO NOT misuse the GATOR® Utility Vehicle, it is a utility vehicle NOT a recreation vehicle.
- Sit on the center of the seat and keep both feet within the foot platform perimeter. Clean foot platform if dirty, and remove any debris from around foot controls.
- Check for debris or refuse in the battery storage compartment, especially around brake linkage which attaches to axle housing on each side of the transaxle.
- Always use both hands for steering.
- Know location of controls and how and what they operate.
- Never operate utility vehicle while standing.
- Never operate utility vehicle with the cargo box raised.
- Check brake action before beginning vehicle operation. If necessary, have the brakes adjusted or serviced by a trained technician.
- To provide adequate braking ability and traction, DO NOT tow any attachment or loaded trailer unless the utility vehicle cargo box is loaded.
- Inspect vehicle before operating. Be sure hardware is tight. Repair or replace damaged, badly worn, or missing parts. Be sure guards and shields are in good condition and fastened in place. Make any necessary adjustments before operating.
- Keep people and pets out of the work area. Stop the vehicle if anyone enters the area. If an object is hit, stop and inspect the vehicle for damage. Make repairs before operating. Keep the vehicle properly maintained and in good working order.
- Keep headlight lenses clean.
- DO NOT leave vehicle unattended.
- Only operate during daylight or with good artificial light.
- Be careful of traffic when operating near or crossing roadways.
- This vehicle is NOT intended for use on highways or public roadways. It is to be used for off-road use only.
- Avoid sudden starts, stops, or turns.

## OPERATING

---

- Always use a level turn-around area.
- DO NOT wear radio or music headphones while operating the vehicle. Safe operation requires your full attention.
- STAY ALERT: LOOK, LISTEN.

### Park Safely

- Stop the vehicle on a level surface, not on a slope.
- Turn key switch to the OFF "0" position.
- Move directional control lever to the NEUTRAL "N" position.
- Engage park brake.
- Remove key.

### Use Hand Holds

Hand Holds (A) are provided for passenger balance when driving over rough terrain. Use dash bar and side rails on seats for stability.



### Check Wheel Bolts

- A serious accident could occur causing serious injury if wheel bolts are not tight.
- Check wheel bolt tightness after first 10 hours of vehicle operation and semi-annually thereafter.

# OPERATING

## Protect Children and Prevent Accidents

### PROTECT CHILDREN:

- Never assume that children will remain where you last saw them. Stay alert to the presence of children.
- Never carry children in the cargo box area. **DO NOT** let children ride in the cargo box of the utility vehicle or any attachment. **DO NOT** tow children in a cart or trailer.
- Use extra care when coming to blind corners, shrubs, trees, or other objects that may block vision.
- **DO NOT** let children or an untrained person operate the vehicle.
- Before backing or turning, look behind and around the utility vehicle for children.

### HELP PREVENT SERIOUS OR FATAL ACCIDENTS:

- Be alert at all times, drive forward and in reverse carefully. People, especially children, can move quickly into an area of operation.
- Back carefully. Look behind the vehicle, especially for children, before backing up.
- **DO NOT** operate vehicle if under the influence of alcohol or other drugs.
- Misuse and recreational riding can lead to accidents, severe bodily injury or death.

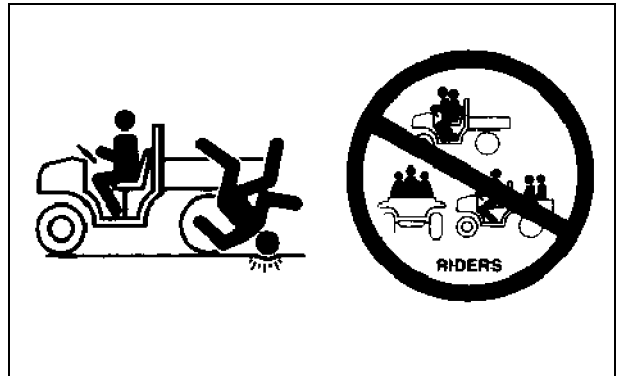

## OPERATING

---

### Avoid Tipping

Accidents resulting in serious injury or death can occur from tipping the utility vehicle. Observe the following practices to help prevent accidents:

- DO NOT misuse this utility vehicle. This utility vehicle is not designed for recreational riding.
- Never allow riders in the cargo box or other areas where seats are not provided.
- Drive very slowly when turning. Sharp turns could cause the utility vehicle to tip over.
- Reduce speed and exercise extreme caution on slopes or on rough ground.
- DO NOT overload vehicle and avoid shifting loads. Reduce load when operating over rough or hilly terrain.
- DO NOT stop or start suddenly when going uphill or downhill. Be especially cautious when changing direction on slopes.
- Stay alert for holes, rocks, and other hidden hazards in the terrain.
- Keep front wheels straight at crest of hill or going over bumps.
- When descending a hill, remove foot from accelerator and apply brakes to reduce speed and maintain control.
- DO NOT make changes or modifications to this utility vehicle.
- Use of a helmet and/or protective gear is recommended for certain operating conditions.

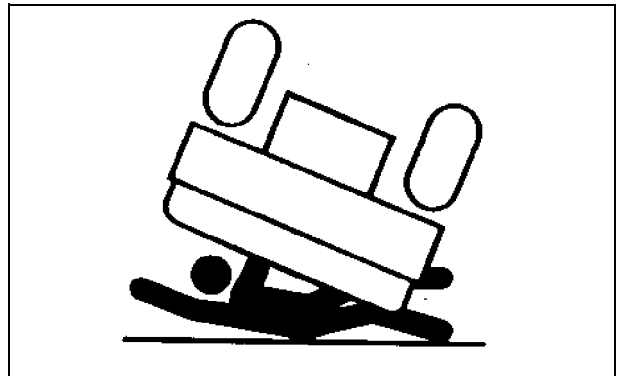

# OPERATING

## Operator Training Required

Study Operating section of this manual before operating the vehicle.

- Operate vehicle in an open, unobstructed area under the direction of an experienced operator.
- Learn the use of all controls.
- Operator experience is required to learn the moving, stopping, turning and other operating characteristics of the vehicle.
- Young drivers may not have the strength or experience to control the utility vehicle. This increases the chances of rolling the vehicle over resulting in severe bodily injury or death.
- The utility vehicle should NOT be operated by anyone under the age of 16 years.

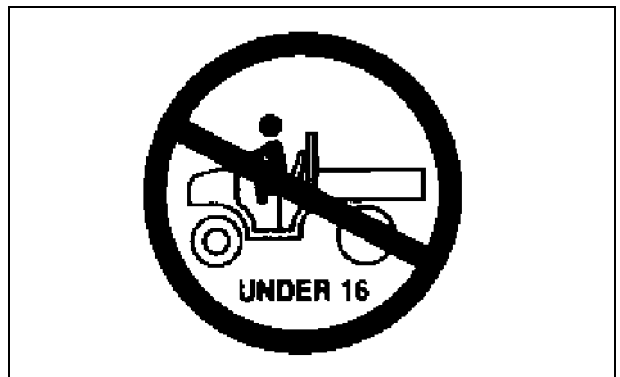

## Keep Riders Off Vehicle

- Seating is provided for operator and one passenger. No riders are allowed in cargo box or anywhere else on vehicle.
- Riders on vehicle are subject to injury such as being struck by foreign objects or being thrown off of the vehicle and severely injured or killed.
- Riders affect the operators ability to control the vehicle as well as its center of gravity. Also, riders could obstruct the operator's view resulting in the vehicle being operated in an unsafe manner.

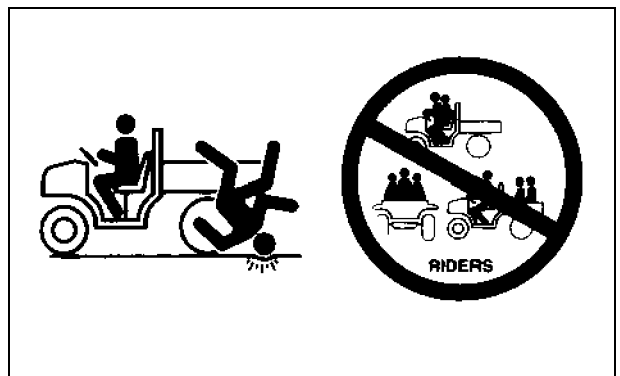

## Wear Appropriate Clothing

- Wear close fitting clothing and safety equipment appropriate for the job.
- Loud noise can cause impairment or loss of hearing, wear a suitable protective device such as earplugs.

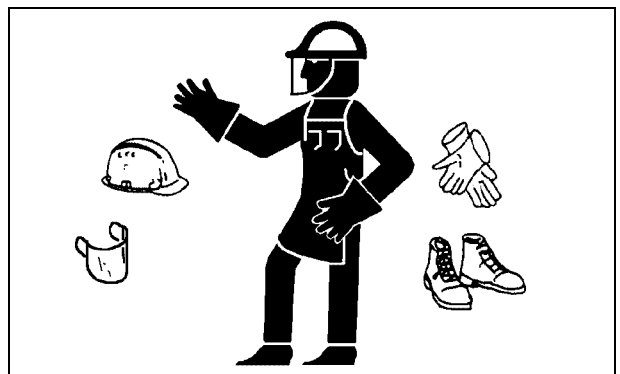

# OPERATING

## Driving On Rough Or Hilly Terrain

**⚠ CAUTION:** Help prevent severe bodily injury or death due to loss of control. Reduce load when operating over rough or hilly terrain.

Reduce speed when turning or when operating around obstacles or rough terrain.

Check the terrain and know the operational capability of the vehicle. Choose places to operate carefully.

- Always use the brakes when going down slopes. The utility vehicle can speed-up when carrying a load. Make sure loads are dispersed evenly and secured. Braking could shift the load and affect vehicle stability.
- Use existing trails. Avoid terrain such as dangerous slopes and impassable swamps. Watch carefully for sharp bumps, holes, ruts, or obstacles.
- Look ahead at terrain. Know what is coming and be prepared to react. Be alert for hazards.
- Keep front wheels straight at crest of hill or going over bumps.
- Adjust speed according to trail, terrain, and visibility conditions.
- Use of a helmet and or protective gear is recommended for certain operating conditions.

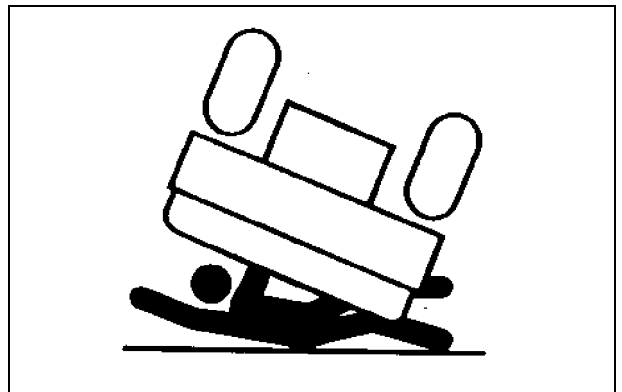

## Driving Across Slopes

**⚠ CAUTION:** Help prevent severe bodily injury or death due to tipping or loss of control. Reduce speed and exercise extreme caution on slopes and in sharp turns. Be especially cautious when changing direction on slopes.

- Sit on center of seat and keep both feet within foot platform perimeter.
- Stay alert for holes, rocks and other hidden hazards in the terrain.
- When riding on soft terrain, turn front wheels slightly uphill to keep utility vehicle on a straight line across the hill.
- If utility vehicle begins to tip, turn front wheel downhill to gain control before proceeding.
- Use of a helmet or protective gear is recommended for certain operating conditions.

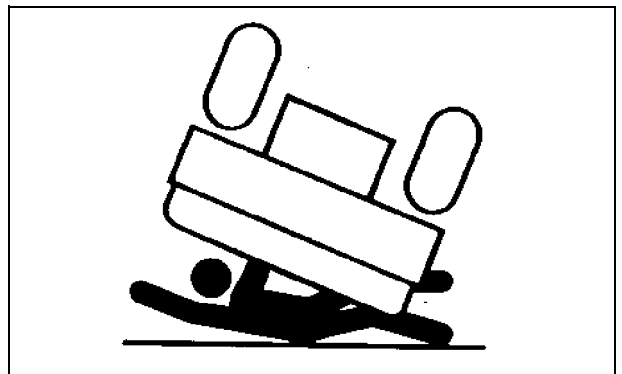



**Suggest:**

**If the above button click is invalid.**

**Please download this document**

**first, and then click the above link**

**to download the complete manual.**

**Thank you so much for reading**

## OPERATING

### Climbing Or Descending A Hill



**CAUTION:** Help prevent severe bodily injury or death due to loss of control. Reduce load when operating over rough terrain.

Reduce speed when turning or when operating around obstacles or on rough ground.

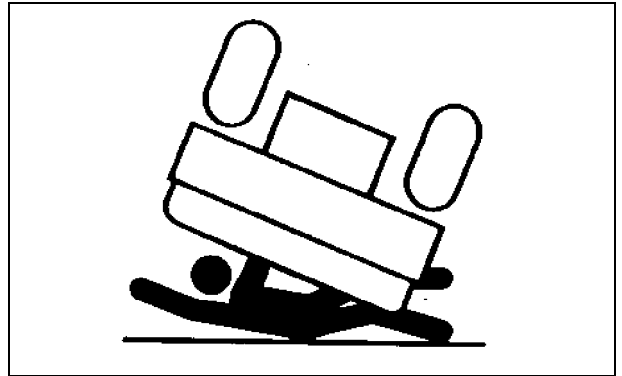

- Always use the brakes when going down slopes. The utility vehicle can speed-up when carrying a load. Make sure loads are dispersed evenly and secured. Braking could shift the load and affect vehicle stability.
- Sit on center of seat and keep both feet within foot platform.
- Never drive past the limit of visibility. Slow down near crest of hill until getting a clear view of the other side.
- Keep front wheels straight at crest of hill or going over bumps.
- DO NOT stop or start suddenly when going uphill or downhill. Be especially cautious when changing direction on slopes.
- If vehicle stops or loses power going up a hill, apply park brake to hold vehicle on slope. Maintain direction of travel and release brake slowly. Back straight down hill slowly while maintaining control. DO NOT turn vehicle sideways. Vehicle is more stable in a straight forward or rearward position.
- When descending a hill, remove foot from accelerator and apply brakes to reduce speed and maintain control.
- Use of a helmet and/or protective gear is recommended for certain operating conditions.

**<https://www.ebooklibonline.com>**

Hello dear friend!

Thank you very much for reading.

Enter the link into your browser.

The full manual is available for immediate download.

**<https://www.ebooklibonline.com>**