

John Deere Combine Quik-Tatch Platforms



OPERATORS MANUAL John Deere Combine Quik-Tatch Platforms

OMH84062 Issue K1 English

John Deere Harvester Works
OMH84062 Issue K1

LITHO IN U.S.A.
ENGLISH





To the Purchaser

This new platform was carefully designed and manufactured to give years of dependable service. To keep it running efficiently, read the instructions in this operator's manual. Each section is clearly identified so you can easily find the information you need—whether it is operation, lubrication, or service. Read the Table of Contents to learn where each section is located. Use the alphabetical index for fast reference.

 This safety alert symbol identifies important safety messages in this manual. When you see this symbol, be alert to the possibility of personal injury and carefully read the message that follows.

In addition to the equipment furnished with your platform, attachments are available to help you do a better job in special crop conditions. These are de-

scribed in the attachments section of this manual, and can be purchased from your John Deere dealer.

“Right-hand” and “left-hand” sides are determined by facing in the direction the platform will travel when in use.

Record your platform serial number in the space provided on page 36. Your dealer needs this information to give you prompt, efficient service when you order parts or attachments. If your platform requires replacement parts, go to your John Deere dealer where you can obtain Genuine John Deere parts—accept no substitutes.

The warranty on this platform appears on your copy of the purchase order which you should have received from your dealer when you purchased the platform.

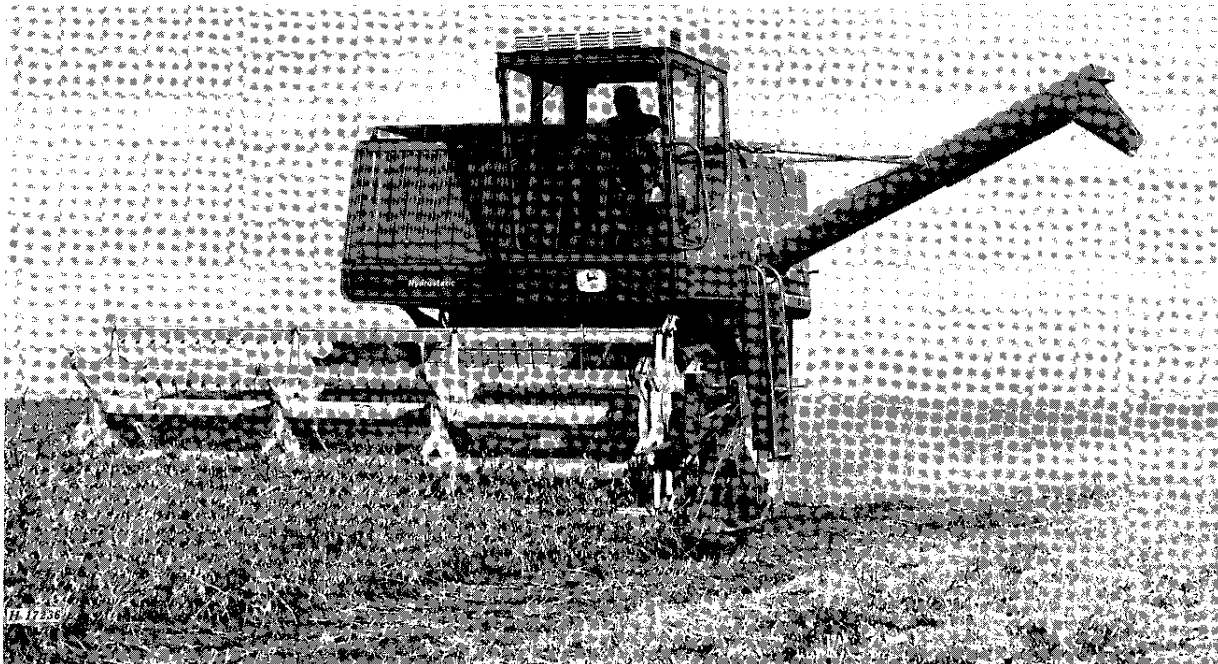



Contents

	Page
Operation	2-7
Lubrication and Periodic Service	8-9
Service	10-16
Trouble Shooting	17-19
Storage	20
Installation	21-26
Attachments	27-29
Assembly	30-35
Specifications	36
Index	37

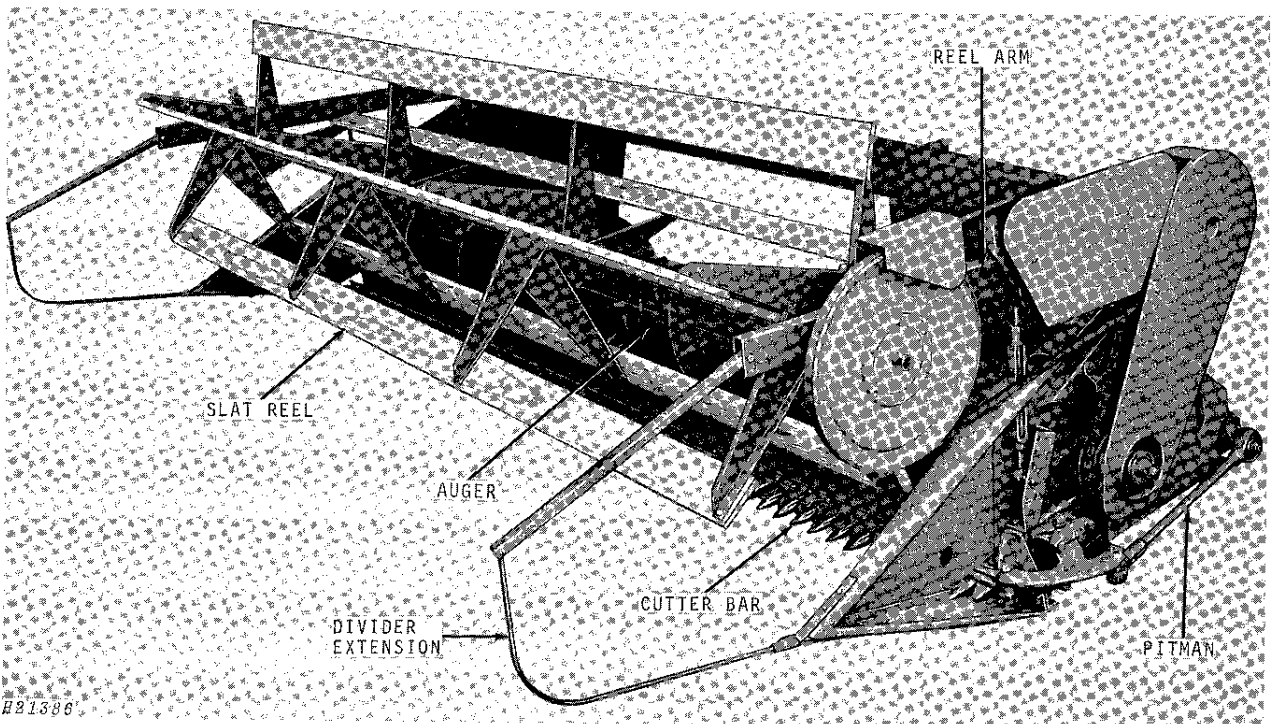

H21398

John Deere Cutting Platform for Combines

<https://www.ebooklibonline.com>

Hello dear friend!

Thank you very much for reading.

Enter the link into your browser.

The full manual is available for immediate download.

<https://www.ebooklibonline.com>



Operation

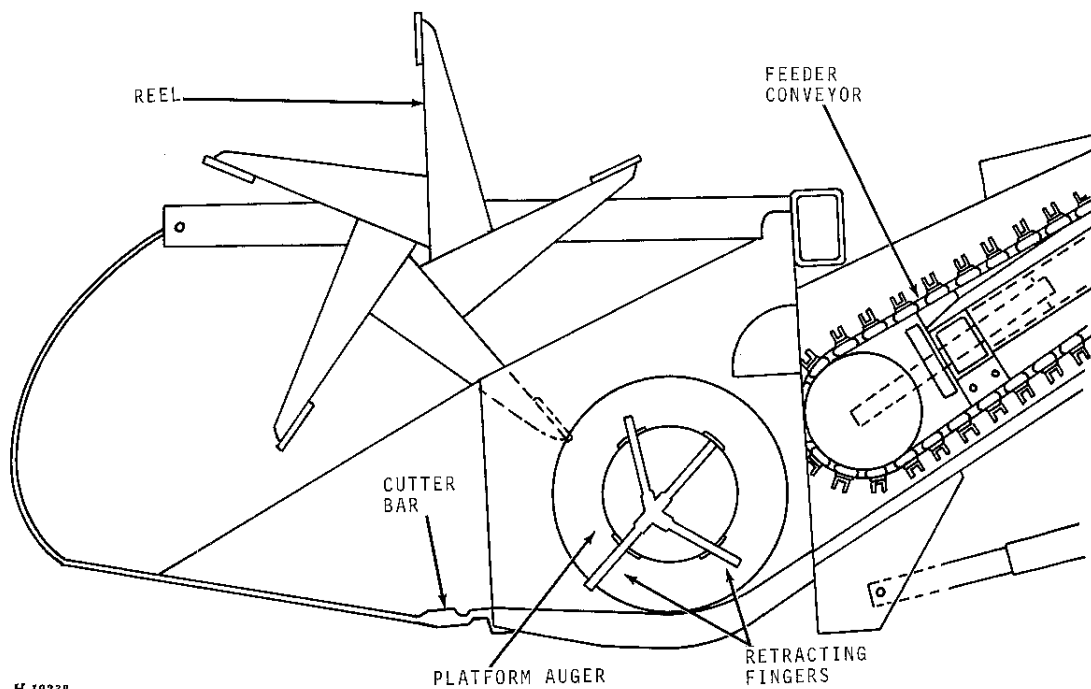

H 19238

The platform receives the crop and moves it to the front of the combine feeder house by means of an auger. Retracting fingers on the auger feed the material to the feeder conveyor.

Height of the platform can be changed by moving the platform height control lever located on the combine steering column. As a safety measure, platform height cannot be changed unless the engine is running. See combine operator's manual.

On combines so equipped, an electric clutch is either engaged or disengaged by operating a switch on the control panel, allowing the platform and feeder house to be started or stopped immediately. See combine operator's manual.

Platform performance depends largely on maintaining correct unit speeds (page 7) and keeping the platform as level as possible (page 15).

While servicing the platform always use the hydraulic cylinder safety stop (page 10).

CUTTER BAR

The cutter bar is basically a multiple series of shears. To cut properly, the knife must run smoothly in the cutter bar, and every knife section must rest on the guard in position to make a shear cut. This means that the guards (page 11), wearing plates (page 12), and knife clips (page 12) must be in good condition and set correctly. If these parts become loose or worn, the knife will chew and tear the crop instead of cutting it.

To prevent poor cutting and frequent clogging, always keep the knife properly registered (page 11).

Do not run the cutter bar closer to the ground than necessary to cut all the crop. Keep the cutter bar aligned at all times (page 13).

REEL

Reel slats gather the crop, hold it until it is cut by the knife, and then move it into the platform auger. Keep the reel level, at proper height, and at proper speed to feed the cut material uniformly and steadily to the platform auger.

Set reel so the slats, in their lowest position, strike just below the lowest grain heads and slightly ahead of the knife.

In crops that are down and badly tangled, set the reel so it will just clear the knife and platform auger. In this position, the material is swept back into the platform auger.

Choose a reel speed to match the condition of the crop. Keep speed as fast as possible without shattering the grain or carrying the straw around over the top of the reel. Usually, slow ground travel speed requires a slow reel speed.

Adjust reel speed by repositioning the reel drive chain on different drive and driven sprockets (pages 4 and 5).

Reel Adjustments

Forward or Rearward Adjustment

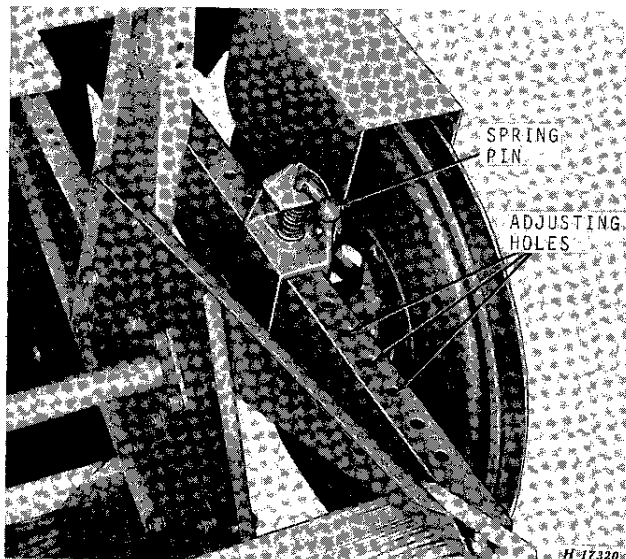

A series of holes is provided on the reel support arms so the reel can be moved forward or rearward. Lift up the spring pin, move the reel to desired position, and install pin. Be sure to adjust both sides evenly.

Check drive belt tension and adjust if necessary.
Page 14.

Height Adjustment (Manual Control)

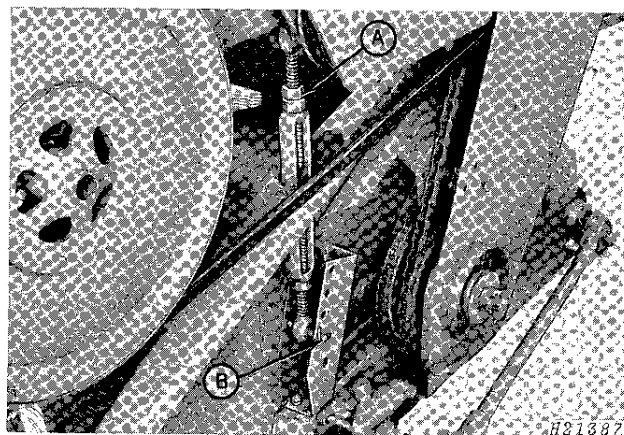

Reel arm turnbuckles, located at each end of cutting platform, are used to adjust the reel up or down. Loosen lock nut "A," turn turnbuckle, and tighten lock nut "A."

CAUTION: The reel arm is heavy and must be supported when removing pin.

The reel can also be adjusted by removing pin "B" and positioning to desired height.



be careful.....
avoid accidents

X 1275

4 Operation

Reel Speeds

Reel speed may be changed by positioning the drive chain on different combinations of drive sprockets on the auger shaft and driven sprockets on the countershaft. When changing the reel speed, always position the drive chain on the inside sprocket on the auger shaft. The two auger shaft sprockets are inter-

changeable to insure correct drive chain alignment (page 5). The countershaft sprockets also must be positioned correctly (page 5).

Whenever the 47-tooth sprocket is used on the auger shaft, the front support bracket for the shield will have to be repositioned as shown below.

NOTE: Shields have been removed for illustrative purposes.

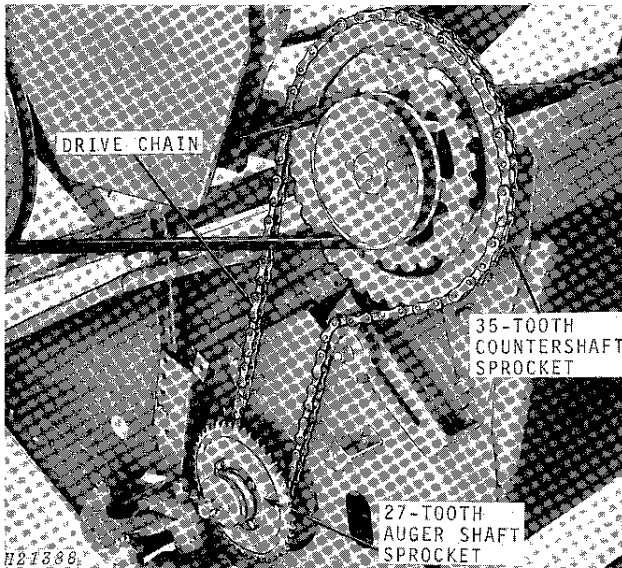

26 rpm

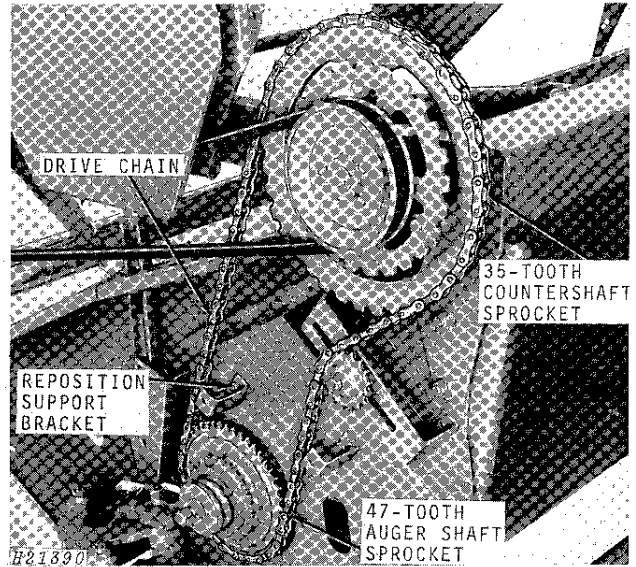

46 rpm

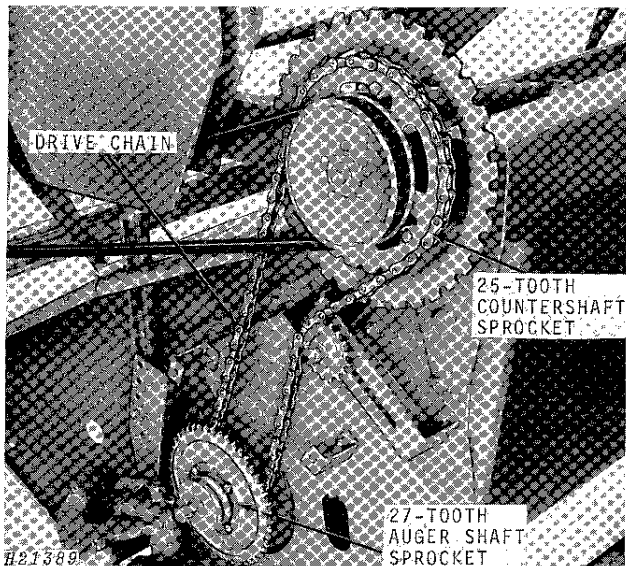

36 rpm

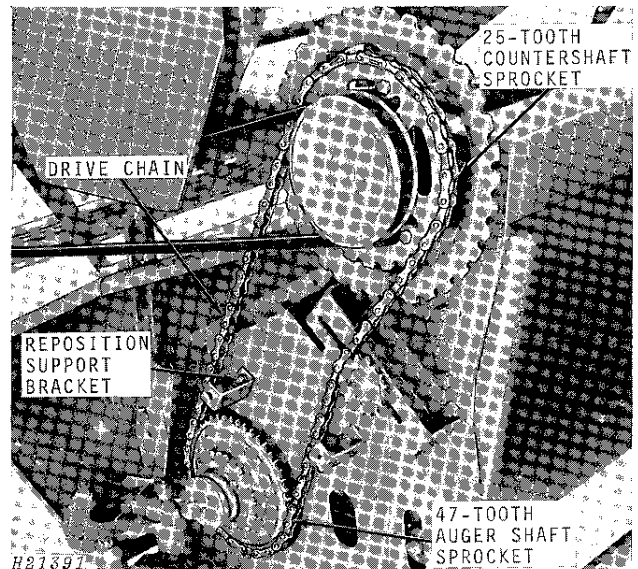

63 rpm

Interchanging Auger Shaft Sprockets

1. (Not Illustrated) Remove reel drive shield and drive chain.

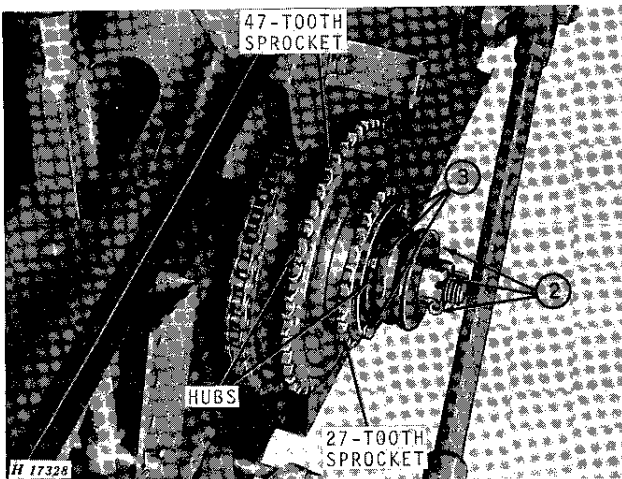

2. Remove cotter pin, castellated nut, and cup washer.

3. Remove four cap screws and slide both sprockets off the auger shaft.

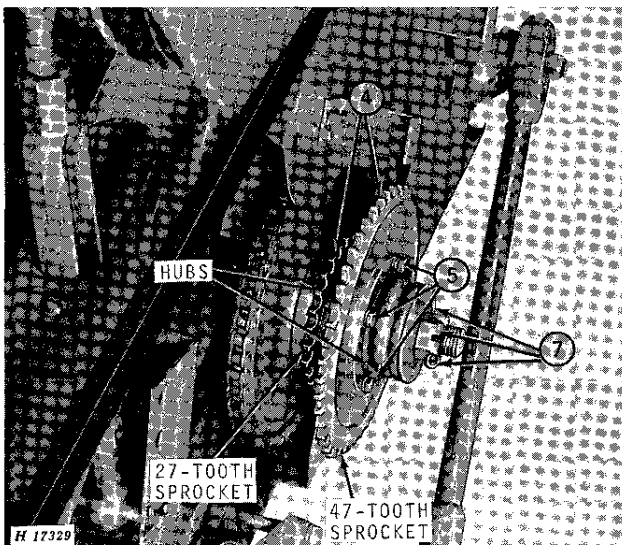

4. Slide the desired sprocket on the shaft first with the wide hub in; then slide second sprocket on with the wide hub out.

5. Install cap screws and tighten.

6. (Not Illustrated) Install drive chain (add or remove chain links as necessary) and adjust tension (page 14).

7. Install cup washer, castellated nut, and cotter pin. Install reel drive shield.

Repositioning Countershaft Sprockets

1. (Not Illustrated) Remove reel drive shield and drive chain.

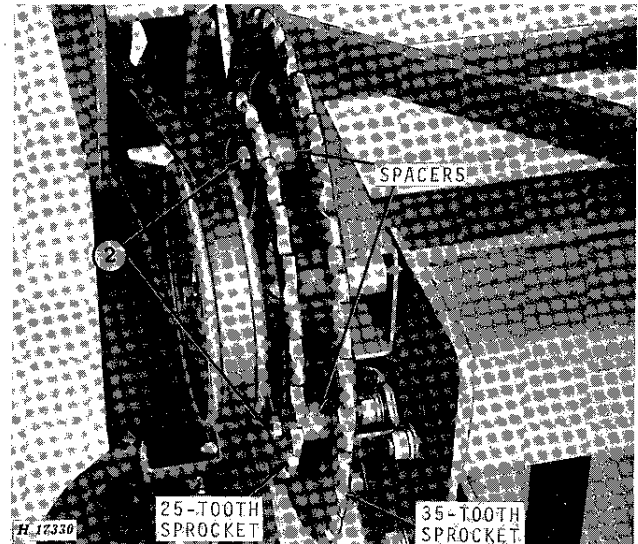

2. The illustration above shows the 25-tooth sprocket in drive position. To switch to the 35-tooth sprocket, remove three cap screws and spacers between the two sprockets.

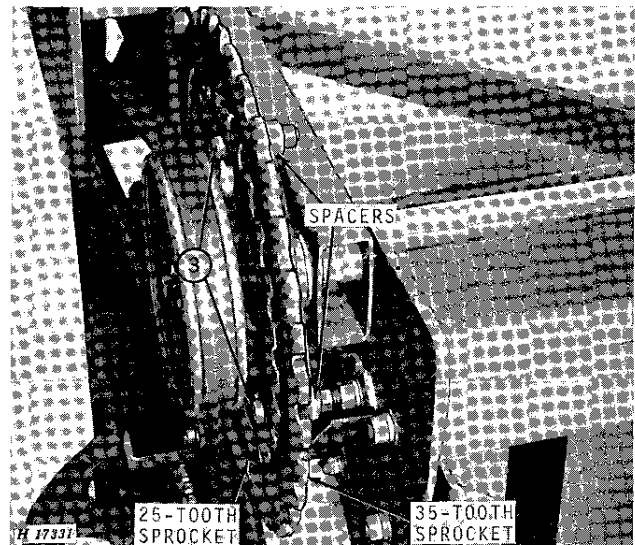

3. Install cap screws with the spacers on the back side of the 35-tooth sprocket. Tighten cap screws.

4. (Not Illustrated) Install drive chain (add or remove links as necessary) and adjust tension (page 14). Install reel drive shield.

5. When returning to the 25-tooth sprocket, reposition the spacers between sprockets.

PLATFORM AUGER

A 1/8- to 5/8-inch clearance between the auger flights and platform bottom and between the auger flights and the auger stripper is required for most crops and conditions to get smooth even feeding.

If the auger is too high or does not have the same relationship at both ends, material will be carried around the auger and will not be fed properly to the feeder conveyor.

It may be necessary to raise the auger when combining coarse stemmed crops or heavy windrows.

Adjusting Auger Height

On right-hand side of platform, loosen two nuts "A." To raise the auger, loosen nut "B" and tighten nut "C." To lower the auger, loosen nut "C" and tighten nut "B."

On the left-hand side, loosen nuts "A" and nut "B." To raise the auger, tighten bolt "C." To lower the auger, loosen bolt "C." Tighten nut "B" and nuts "A."

IMPORTANT: Keep auger level; be certain there is ample clearance for the auger fingers and proper clearance between auger flights and stripper. Check drive chain tension.

Adjusting Auger Forward and Rearward

On right-hand side of platform, loosen the two bolts "D" in the adjusting bracket. Move auger to the necessary position, and tighten nuts.

NOTE: Be careful not to destroy finger height setting.

On left-hand side, move the auger rearward by loosening nut "D" and tightening nut "E." Move the auger forward by loosening nut "E" and tightening nut "D."

Adjusting Finger Clearance

Retracting auger fingers are adjustable to obtain the best delivery to the feeder conveyor.

Maintain equal clearance between both the end finger bearings and the finger cranks, as illustrated. Loosen lock nuts "F" and "G" and move shaft in or out as necessary. Then secure shaft in position by tightening lock nuts "F" and "G."

Adjusting Finger Height

On the right-hand side of the platform, loosen the two bolts "H." To move the extended fingers down on the auger tube, pivot the top of bracket forward. Tighten nuts "H." Fingers must clear platform bottom 1/8 to 1/4 inch. To move fingers up, reverse the procedure.

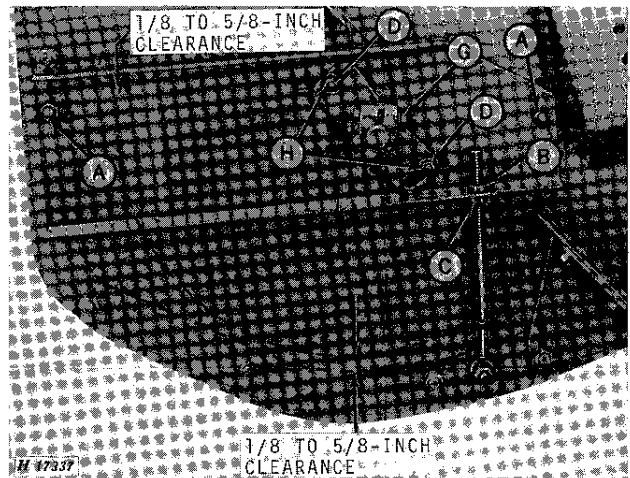

Right-Hand Side

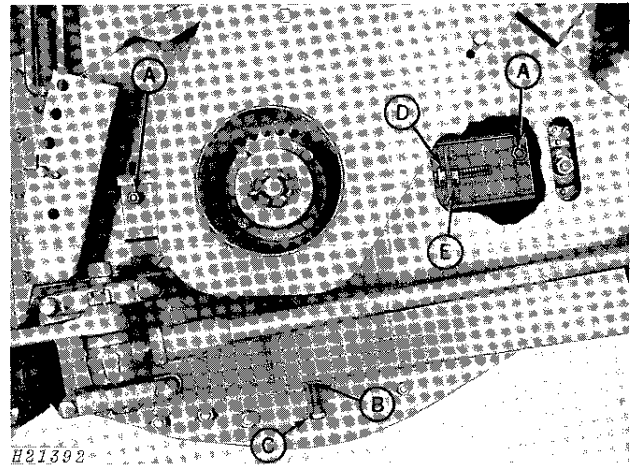

Left-Hand Side

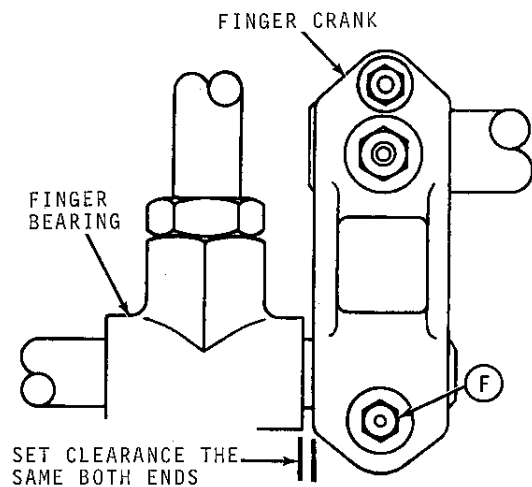

H 17339

NOTE: Be careful not to destroy the auger forward and rearward adjustment.

OPERATING SPEEDS

Description	Speed	Page
Reel	26 - 63 rpm	4
Knife	465 cycles per min.	11
Knife and Platform Countershaft: 3300, 4400, 6600, and 7700 Combines	465 rpm	--
45, 55, 95, and 105 Combines	470 rpm	--
Platform Auger	177 rpm	6

SAFETY SUGGESTIONS



Study these suggestions carefully and insist that they be followed by those working with you and for you.

All machinery should be operated only by responsible persons who have been delegated to do so.

Never clean, oil, or adjust the platform when it is running.

Clothing worn by operator should be fairly tight and belted. Loose jackets, shirts, or sleeves should never be worn because of the danger of getting into moving parts.

Make certain everyone is clear of the combine before starting the combine engine so no one can be struck by moving parts.

Always disengage drive and shut off the combine engine before working on the platform.

Be certain shields and guards are in place and in good condition before starting in the field.

Never attempt to clear obstructions off the platform unless the combine is stopped and the combine engine is shut off.

Escaping hydraulic fluid under pressure can have sufficient force to penetrate the skin, causing serious personal injury. Before disconnecting lines, be sure to relieve all pressure. Before applying pressure to the system, be sure all connections are tight and that lines, pipes, and hoses are not damaged. Fluid escaping from a very small hole can be almost invisible. Use a piece of cardboard or wood, rather than hands, to search for suspected leaks.

If injured by escaping hydraulic fluid, see a doctor at once. Serious infection or reaction can develop if proper medical treatment is not administered immediately.



Lubrication and Periodic Service

SYMBOLS	
	Lubricate Every 5 Hours of Operation with John Deere Multi-Purpose Lubricant or an equivalent SAE Multipurpose-Type Grease.
	Lubricate Every 10 Hours of Operation with John Deere Multi-Purpose Lubricant or an equivalent SAE Multipurpose-Type Grease.
	Oil Every 50 Hours of Operation with SAE 30 Oil.

LUBRICATE AS REQUIRED

CAUTION: Never lubricate or service platform while combine engine is running.

Chains

Lubricate chains at frequent intervals with SAE 30 oil. Operate chains for several minutes so they are warm when oil is applied.

NOTE: Genuine John Deere Chain Lube in an aerosol can (part number PT508) may be obtained from your John Deere dealer. This is an ideal lubricant for roller drive chains.

Knife

The amount of lubricant to use on a knife depends on the conditions in which the work is being done. When the grain is being topped and the cutter bar is carried some distance from the ground, liberal lubrication with SAE 30 oil is permissible. In conditions where the cutter bar must operate close to the ground, it is better not to use oil except for a small amount on the knife holders.

KEEP LUBRICANTS CLEAN!

Use only high-grade lubricants which have been stored in clean containers. Wipe away all grease and dirt from grease fittings before lubricating.

5-HOUR SERVICE

Slat Reel Pipe or Pick-Up Reel Shaft Housing—Both Sides

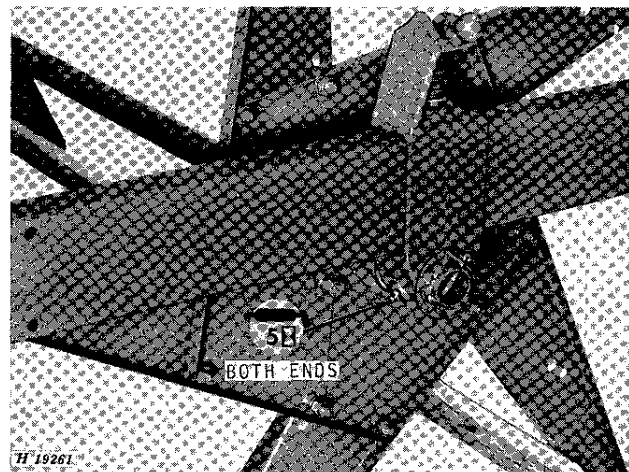

Slat Reel

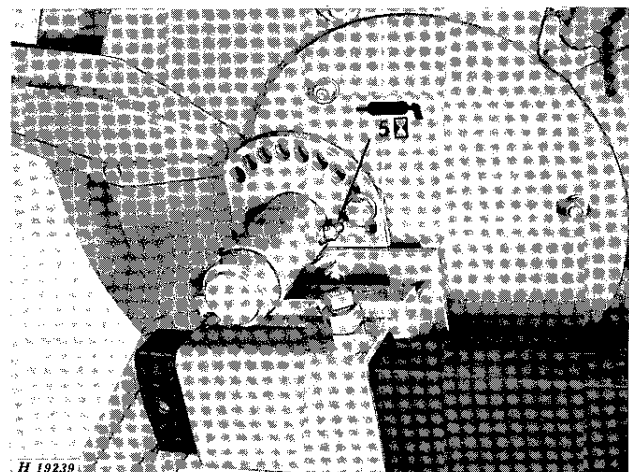

Pick-Up Reel

10-HOUR SERVICE

Perform all 5-hour lubrication.

Knife Drive Pitman, Bell Crank, and Knife Head

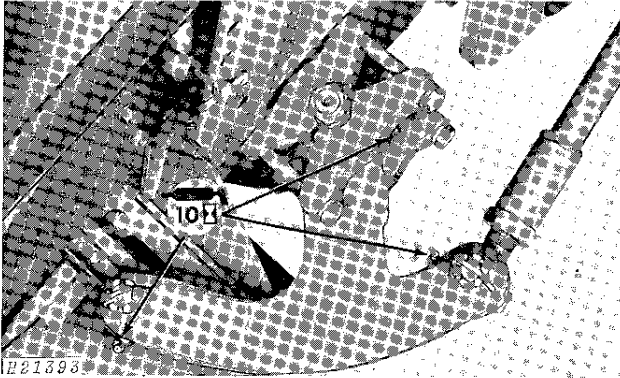

Reel Drive

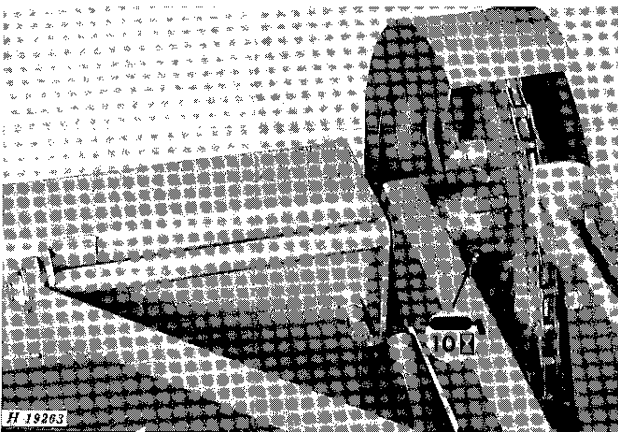

Reel Drive Belt

Check tension, page 14.

Reel Drive Chain

Check tension, page 14.

Platform Auger Drive Chain

Check tension, page 14.

50-HOUR SERVICE

Perform all 5- and 10-hour lubrication and periodic services.

Pickup Reel Finger Coils

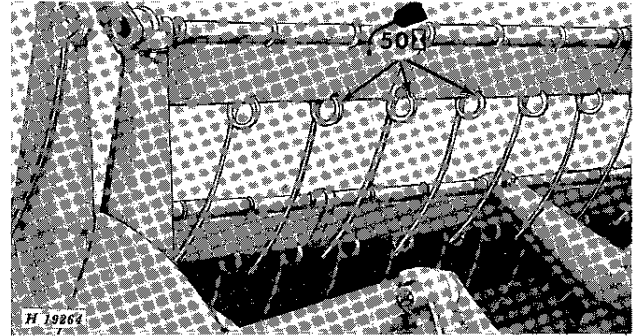

Cutter Bar and Knife

- Check for broken sections, page 11.
- Check register, page 11.
- Check alignment, page 13.
- Check guards, page 11.
- Check knife clips, page 12.
- Check wearing plates, page 12.

100-HOUR SERVICE

Perform all 5-, 10-, and 50-hour lubrication and periodic services.

Platform

Check level, page 15.

Bell Crank

Check adjustment, page 10.

500-HOUR OR YEARLY SERVICE

Perform all 5-, 10-, 50- and 100-hour lubrication and periodic services.

Platform Auger Slip Clutch

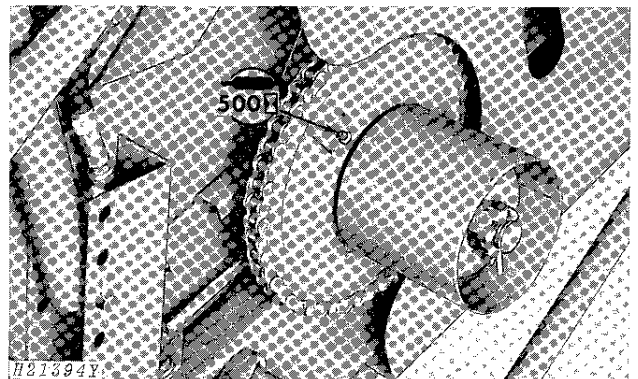

Remove pipe plug and install grease fitting. After lubrication, reinstall pipe plug to prevent more frequent lubrication of slip clutch.



Service

HYDRAULIC CYLINDER SAFETY STOP

CAUTION: When working under the platform always place the hydraulic cylinder safety stop in safety position.

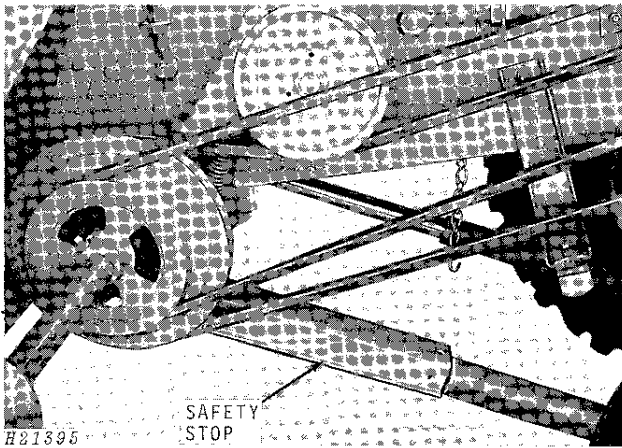

Safety Position

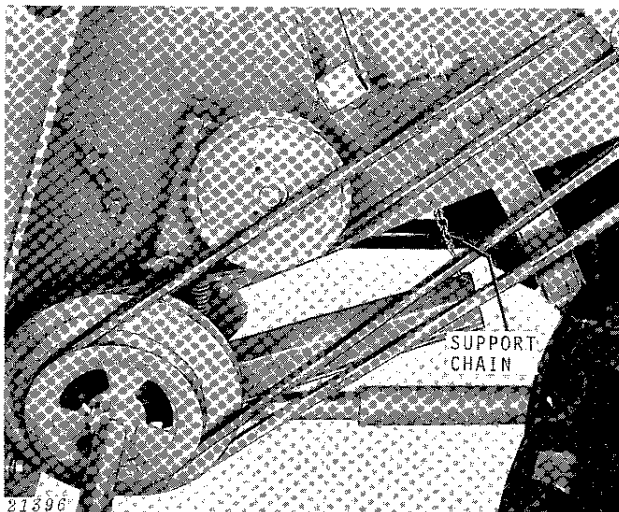

Storage Position

To place hydraulic cylinder safety stop in safety position first extend hydraulic cylinders. Disconnect support chain from safety stop and position safety stop on piston rod. After completing the work on the platform, attach safety stop to support chain for storage.

CUTTER BAR

Bell Crank Bearing Adjustment

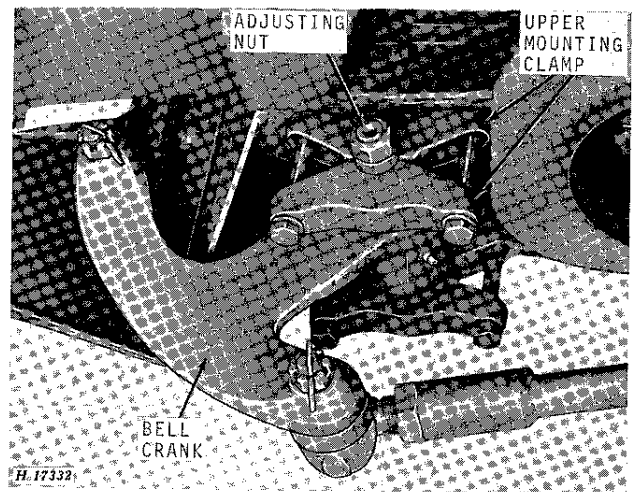

Check the tapered roller bearing (located in bell crank) every 100 hours of operation for vertical end play. If vertical end play exists, make the following adjustments:

Loosen top bolts in mounting clamp and tighten adjusting nut until end play disappears; tighten mounting clamp bolts.

Removal and Installation of Knife

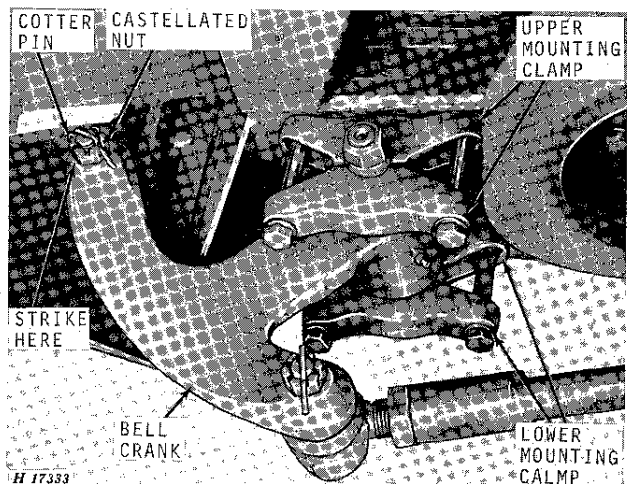

To remove knife, remove cotter pin and castellated nut from knife head. Loosen cap screws in lower mounting clamp; remove upper mounting clamp. Strike the bell crank a sharp blow with a hammer at knife head to break loose the "tapered lock." Lift bell crank off knife head and pull knife out of cutter bar.

To install the knife, reverse the above procedure.

IMPORTANT: Be careful to align knife section with guard slots so sections will not bind. After centering sections, tighten four cap screws in mounting clamps.

Knife Register

The knife is in proper register when the sections pass an equal distance, through adjacent guards at each end of the pitman stroke. If such is not the case, the cut is incomplete on one stroke and excessive on the other, resulting in poor cutting and frequent clogging of the knife.

To adjust register, remove cotter pin from tie rod end and loosen nut. Break tie rod end loose from bell crank with lead hammer or use an automotive-type tie rod removal tool. Remove nut and lower pitman tie rod end.

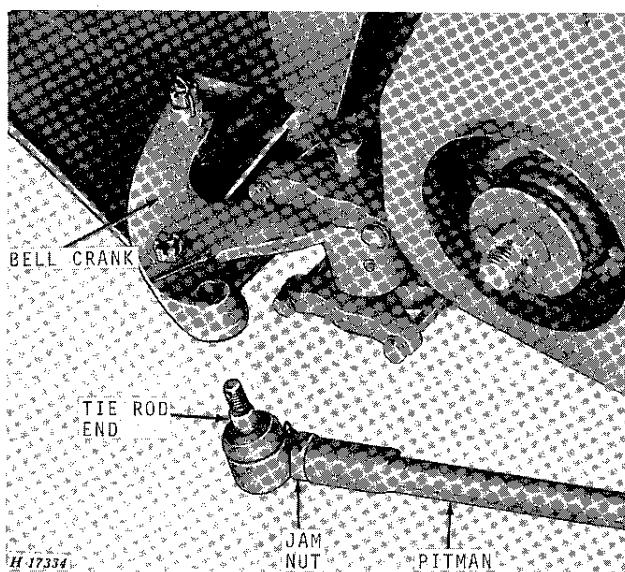

Loosen 1-1/2-inch jam nut and revolve tie rod end as many full turns, either direction, as necessary. Each complete turn is equivalent to 1/16 inch. Attach tie rod end to bell crank, check register, and tighten jam nut.

IMPORTANT: Tie rod end must fit freely into tapered hole in bell crank to prevent breaking pitman. If necessary, bend pitman to make tie rod end fit freely in tapered hole.

Guard Alignment

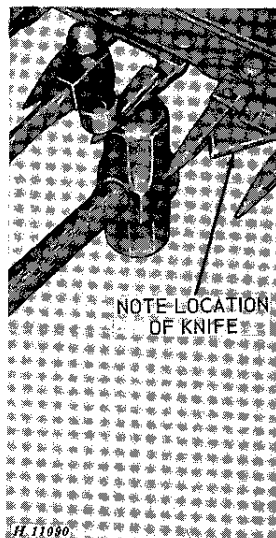

Setting Guard Down

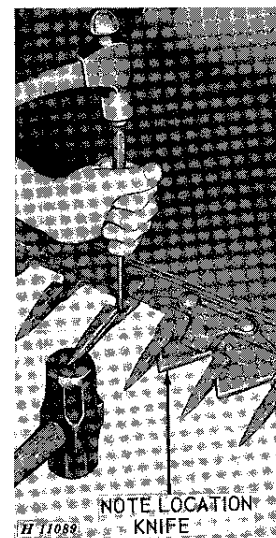

Setting Guard Up

NOTE: Before aligning guards be sure the cutterbar is aligned (page 13).

Set each guard up or down as necessary to obtain a shear cut between the knife section and the guard. Tighten the bolt as each guard is aligned.

NOTE: Guard lip must be parallel with shear edge of guard.

If it is necessary to replace guards, be certain to align new guards to insure a shear cut.



Suggest:

If the above button click is invalid.

Please download this document

first, and then click the above link

to download the complete manual.

Thank you so much for reading

CUTTER BAR—Continued

Knife Clip Adjustment

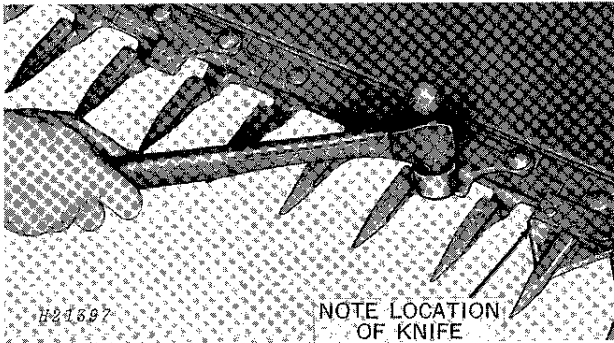

Setting Knife Clip Down

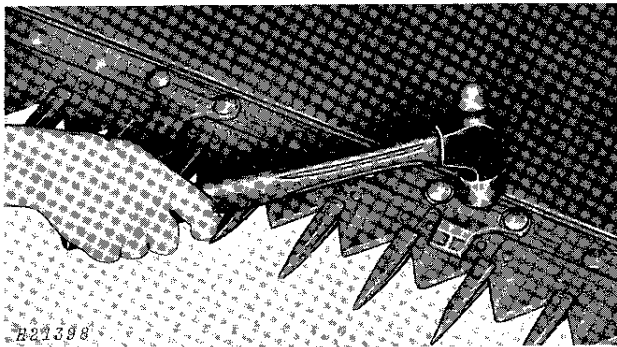

Setting Knife Clip Up

Knife clips must keep sections from lifting off guards and permit knife to slide without binding. Set knife clips after guards are aligned. Never bend down a knife clip when the knife is under it. Tap the knife clips up or down until the knife will slide under them without binding.

If knife clip is too tight, strike it between the bolts. After setting the knife clips, oil, and make certain the knife works freely.

Wearing Plate Adjustment

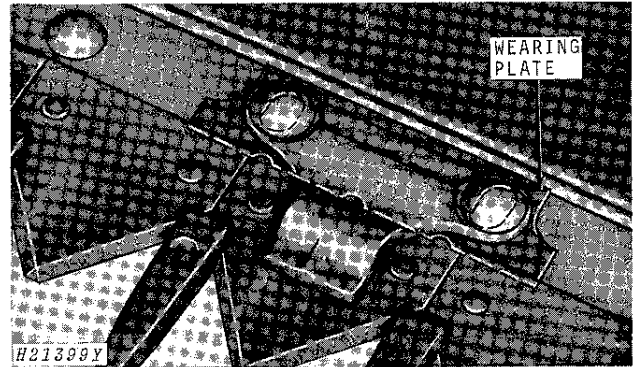

Wearing plates are located along the entire length of the knife back and are adjustable to compensate for wear on the knife back. Turned-down edges of the wearing plates must line up with each other to give the knife back a straight bearing along its entire length.

Hold knife forward with fingers and adjust wearing plates finger tight against knife back. Do not drive with a hammer or pry up with a screwdriver. After moving wearing plates forward, or after replacing them, be sure to tighten the guard bolts securely.

The world's best safety device is a careful operator.

<https://www.ebooklibonline.com>

Hello dear friend!

Thank you very much for reading.

Enter the link into your browser.

The full manual is available for immediate download.

<https://www.ebooklibonline.com>