

Combine Quick-Tatch Platforms



JOHN DEERE

OPERATORS MANUAL

Combine Quick-Tatch
Platforms

OMH86807 Issue J3 English

John Deere Harvester Works
OMH86807 Issue J3

LITHO IN U.S.A.
ENGLISH





To the Purchaser

This new platform was carefully designed and manufactured to give years of dependable service. To keep it running efficiently, read the instructions in this operator's manual. Each section is clearly identified so you can easily find the information you need—whether it is operation, lubrication, or service. Read the Table of Contents to learn where each section is located. Use the alphabetical index for fast reference.

 This safety alert symbol identifies important safety messages in this manual. When you see this symbol, be alert to the possibility of personal injury and carefully read the message that follows.

In addition to the equipment furnished with your platform, attachments are available to help you do a better job in special crop conditions. These are de-

scribed in the attachments section of this manual, and can be purchased from your John Deere dealer.

"Right-hand" and "left-hand" sides are determined by facing in the direction the platform will travel when in use.

Record your platform serial number in the space provided on page 40. Your dealer needs this information to give you prompt, efficient service when you order parts or attachments. If your platform requires replacement parts, go to your John Deere dealer where you can obtain Genuine John Deere parts—accept no substitutes.

The warranty on this platform appears on your copy of the purchase order which you should have received from your dealer when you purchased the platform.

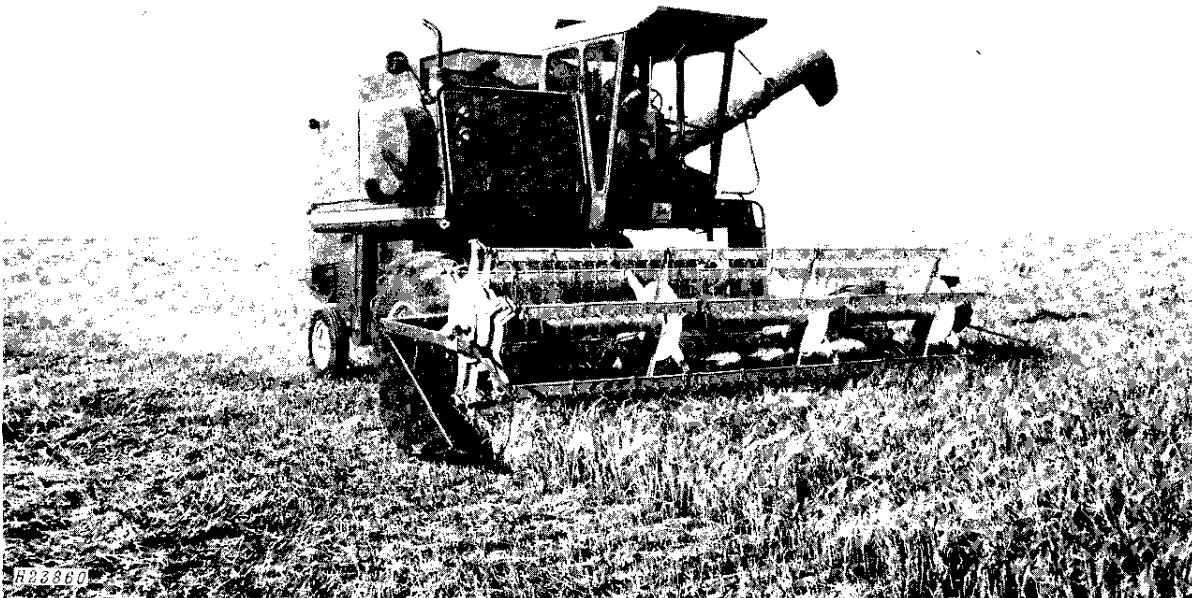

JOHN DEERE QUIK-TATCH PLATFORMS

PREDELIVERY CHECK LIST

Inspect the platform thoroughly after it is completely assembled to be sure it is in good running order before delivering it to the customer. The following check list is a reminder of points to inspect. Check off each item as it is found satisfactory or after proper adjustment is made.

- Look the platform over carefully and remove all tools.
- Be sure all sheaves are in alignment. Check tension of belts.
- Check all chains for proper installation, alignment, and adjustment.
- Check all bolts and nuts to be sure they are tight.
- Reel must be level and centered between platform sides. Reel support arms must be square with platform top beam.
- Check the register of the knife. Sections must pass the same distance through adjacent guards.
- Check alignment of the guards. Set guards up or down as necessary.
- Check for clearance between retracting fingers and platform bottom. If necessary, adjust so fingers will not gouge into platform bottom.
- Check for equal clearance between end finger bearings and finger cranks, adjust if necessary.

OWNER REGISTER

Name _____
Post Office _____
County _____ State _____
Platform Serial No. _____
Date Purchased _____

- Platform cutterbar must be level and parallel with the front axle tube.
- Check, and if necessary, lubricate all lubrication points. (See lubrication charts.)
- Check to be sure right-hand coupler shield is installed on feeder houses with lower shaft extended on right-hand side.
- Deliver the operator's manual to the purchaser. Explain the safe operation and adjustments and service of this machine as outlined in the operator's manual.
- Remove this predelivery check list and retain for future reference.

I have performed the above predelivery service to the best of my ability.

Date _____

Name _____

(Signature of Serviceman)

<https://www.ebooklibonline.com>

Hello dear friend!

Thank you very much for reading.

Enter the link into your browser.

The full manual is available for immediate download.

<https://www.ebooklibonline.com>

SHIPPING BUNDLES

Bundle No.	Description	Bundle No.	Description
BH 75854	Platform, Cutting, 10-Ft.	BH 75180	* Reel Arms (Wood Slats) - 10-Ft.
BH 75856	Platform, Cutting, 13-Ft.	BH 75026	* Reel Arms (13-through 16-Ft.) (Wood Slats) (2 used)
BH 75855	Platform, Belt Pickup, 13-Ft.	BH 75179	* Reel Arms (16-Ft.) (Metal Slats) (2 used)
BH 75858	Platform, Cutting, 14-Ft.	BH 75026	* Reel Arms (18- and 20-Ft.) (Wood and Slats)
BH 75857	Platform, Belt Pickup, 14-Ft.	BH 75180	
BH 75859	Platform, Cutting, 15-Ft.	BH 75027	* Reel Arms (18- and 20-Ft.) (Metal and Slats)
BH 75860	Platform, Cutting, 16-Ft.	BH 75179	
BH 75861	Platform, Cutting, 18-Ft.	BH 75027	* Reel Arms (22-Ft.) (Metal Slats) (2 used)
BH 75862	Platform, Cutting, 20-Ft.	BH 75027	* Reel Arms (24-Ft.) (Metal Slats) (2 used)
BH 75863	Platform, Cutting, 22-Ft.	BH 75091	* Truss Rod Parts, 20-Ft.
BH 75864	Platform, Cutting, 24-Ft.	BH 75103	* Truss Rods, 20-Ft.
H 25385	* Reel Slats - (Wood) - 10-Ft. (5 used)	BH 75092	* Truss Rod Parts, 22-Ft.
H 24049	* Reel Slats - (Wood) - 13-Ft. (5 used)	BH 75104	* Truss Rods, 22-Ft.
H 22818	* Reel Slats - (Wood) - 14-Ft. (5 used)	BH 75092	* Truss Rod Parts, 24-Ft.
H 62942	* Reel Slats - (Wood) - 15-Ft. (5 used)	BH 75105	* Truss Rods, 24-Ft.
H 22819	* Reel Slats - (Wood) - 16-Ft. (5 used)	BH 75183	Reel Support Arms
H 79258	* Reel Slats - (Metal) - 16-Ft. (5 used)	BH 75028	Reel Support
H 22820	* Reel Slats - (Wood) - 18-Ft. (5 used)	BH 60118	Fixed Reel Drive Parts
H 79259	* Reel Slats - (Metal) - 18-Ft. (5 used)	BH 75517	Fixed Reel Drive Parts
H 28027	* Reel Slats - (Wood) - 20-Ft. (5 used)	BH 75933	Fixed Reel Drive
H 79260	* Reel Slats - (Metal) - 20-Ft. (5 used)	BH 60621	Divider Points
H 79261	* Reel Slats - (Metal) - 22-Ft. (5 used)	AH 62583	Loop Dividers (2 used)
H 79262	* Reel Slats - (Metal) - 24-Ft. (5 used)	BH 75476	Right-hand Coupler Shield - Required only when platform is attached to an Intermediate Feeder House or a Corn Feeder House.
AH 77185	* Reel Pipe, 10-Ft.		
AH 75951	* Reel Pipe, 13-Ft.		
AH 77188	* Reel Pipe, 14-Ft.		
AH 77184	* Reel Pipe, 15-Ft.		
AH 77189	* Reel Pipe, 16-Ft.		
AH 77190	* Reel Pipe, 18-Ft.		
AH 77186	* Reel Pipe, 20-Ft.		
AH 77187	* Reel Pipe, 22-Ft.		
AH 77183	* Reel Pipe, 24-Ft.		

* Not required when combine is to be equipped with pickup reel.

NOTE: Installation instructions are included with pickup reel.



Contents

	Page
Operation	2-9
Lubrication and Periodic Service	10-11
Service	12-20
Trouble Shooting	21-23
Storage	24
Installation	25-30
Attachments	31-33
Assembly	34-39
Specifications	40
Index	41

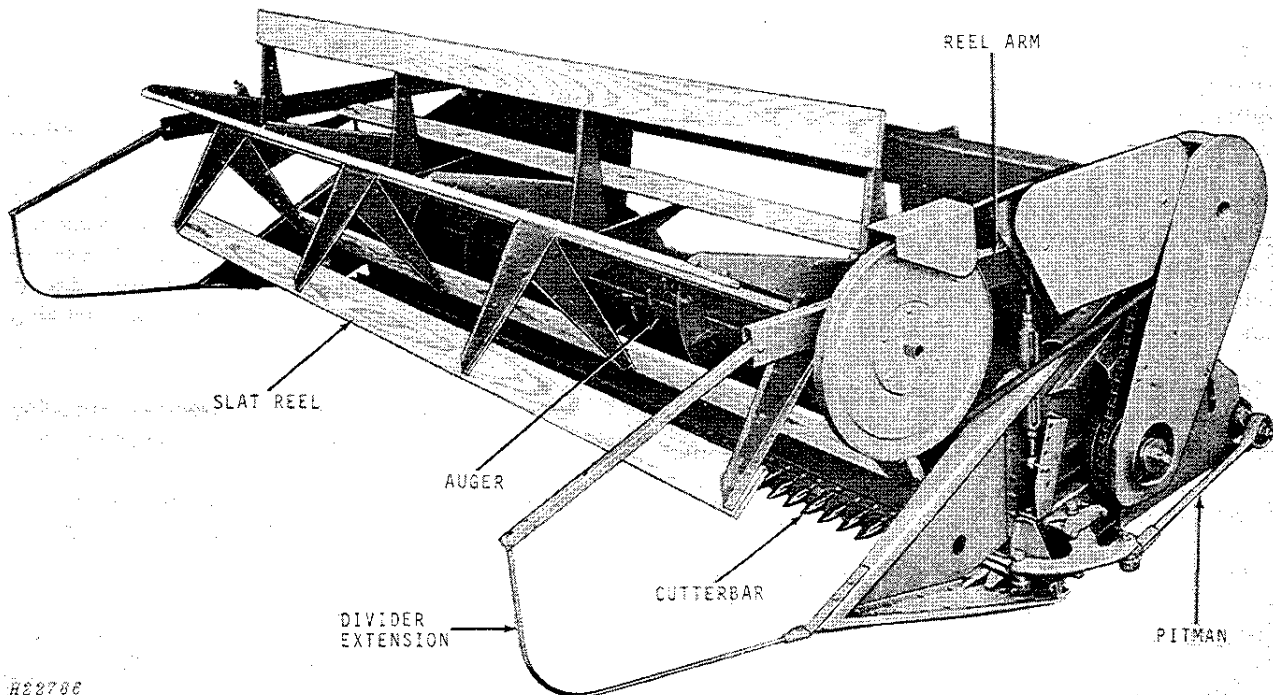

R22786

John Deere Cutting Platform for Combines



Operation

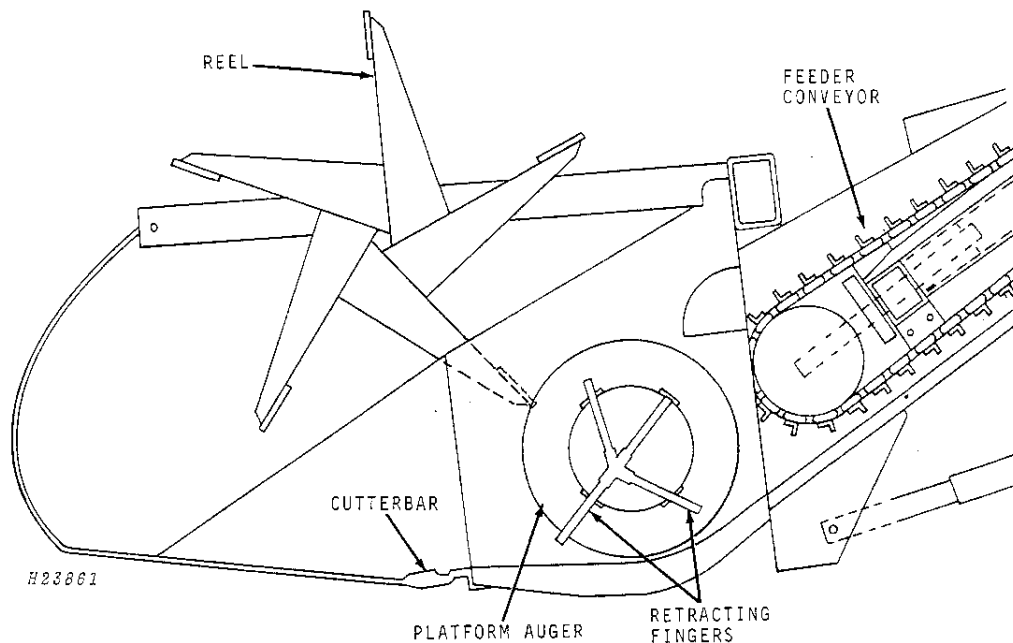

The platform receives the crop and moves it to the front of the combine feeder house by means of a reel, cutterbar, and auger. Retracting fingers on the auger feed the material to the feeder conveyor.

Height of the platform can be changed by moving the platform height control lever located on the combine steering column. As a safety measure, platform height cannot be changed unless the engine is running. See combine operator's manual.

On combines so equipped, an electric clutch is either engaged or disengaged by operating a switch on the control panel, allowing the platform and feeder house to be started or stopped immediately. See combine operator's manual.

Platform performance depends largely on maintaining correct unit speeds (page 9) and keeping the platform as level as possible (page 19).

While servicing the platform always use the hydraulic cylinder safety stop (page 14).

CUTTERBAR

The cutterbar is basically a multiple series of shears. To cut properly, the knife must run smoothly in the cutterbar, and every knife section must rest on the guard in position to make a shear cut. This means that the guards (page 15), wearing plates (page 16), and knife clips (page 16), must be in good condition and set correctly. If these parts become loose or worn, the knife will chew and tear the crop instead of cutting it.

To prevent poor cutting and frequent clogging, always keep the knife properly registered (page 15).

Do not run the cutterbar closer to the ground than necessary to cut all the crop. Keep the cutterbar aligned at all times (page 17).

REEL

Reel slats gather the crop, hold it until it is cut by the knife, and then move it into the platform auger. Keep the reel level, at proper height, and at proper speed to feed the cut material uniformly and steadily to the platform auger.

Set reel so the slats, in their lowest position, strike just below the lowest grain heads and slightly ahead of the knife.

In crops that are down and badly tangled, set the reel so it will just clear the knife and platform auger. In this position, the material is swept back into the platform auger.

Pickup reel fingers gather up downed crops, re-

duce shattering, and provide a more even flow of material to the combine. The fingers on pickup reels are angled to properly lift material before it is cut by the cutterbar. The angle should be selected so a downed crop is uniformly delivered to the platform auger.

Choose a reel speed to match the condition of the crop. Keep speed as fast as possible without shattering the grain or carrying the straw around over the top of the reel. Usually, slow ground travel speed requires a slow reel speed.

Adjust reel speed by repositioning the reel drive chain on different drive and driven sprockets (pages 6 and 7).

REEL ADJUSTMENTS

Forward or Rearward Adjustment for Bat Reel

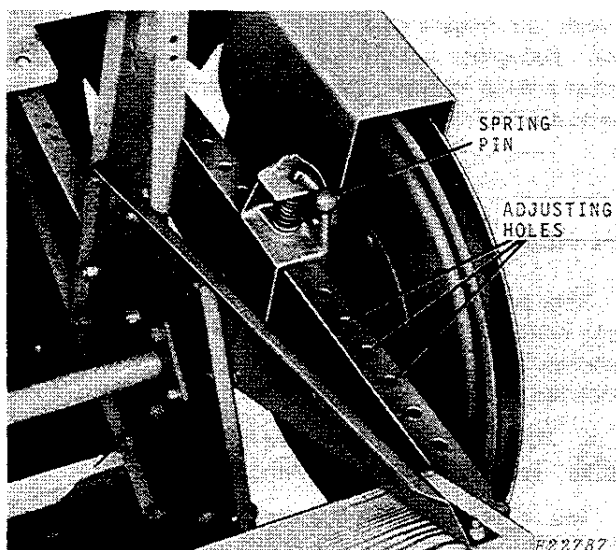

A series of holes is provided on the reel support arms so the reel can be moved forward or rearward. Lift up the spring pin, move the reel to desired position, and install pin. Be sure to adjust both sides evenly.

Check drive belt tension and adjust if necessary (page 18).

Forward or Rearward Adjustment for Pickup Reel

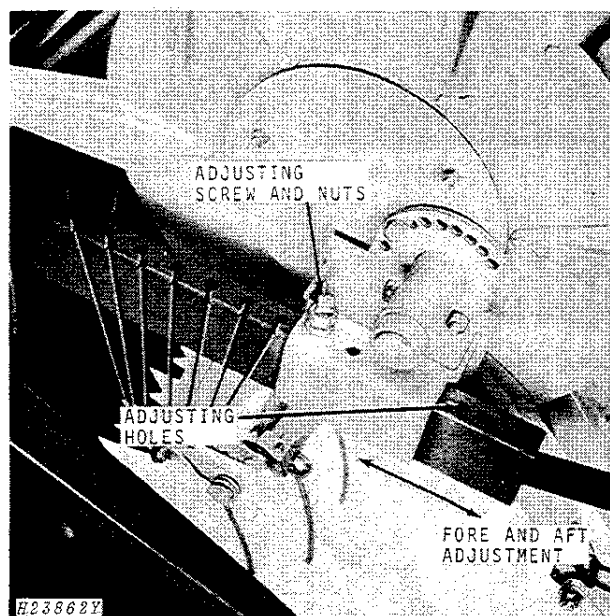

A series of holes is provided on the reel support arms so the reel can be moved forward or rearward. Loosen lock nuts and adjusting screw, move reel to desired position, and tighten adjusting screw and lock nuts. Be certain to adjust both sides evenly.

Be certain fingers are 1 to 5 inches from cutterbar and approximately 4 inches from auger. See illustration in right-hand column at top of page 4.

NOTE: If reel is equipped with hydraulic lift, be certain hydraulic ram is closed (down).

Check drive belt tension and adjust if necessary. See page 18.

PICKUP REEL

Finger Adjustment for Pickup Reel

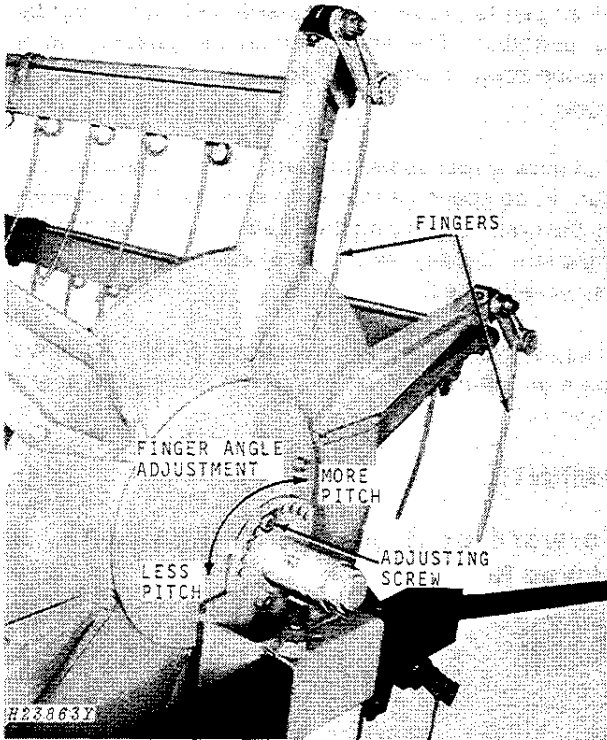

Right-Hand Side Illustrated

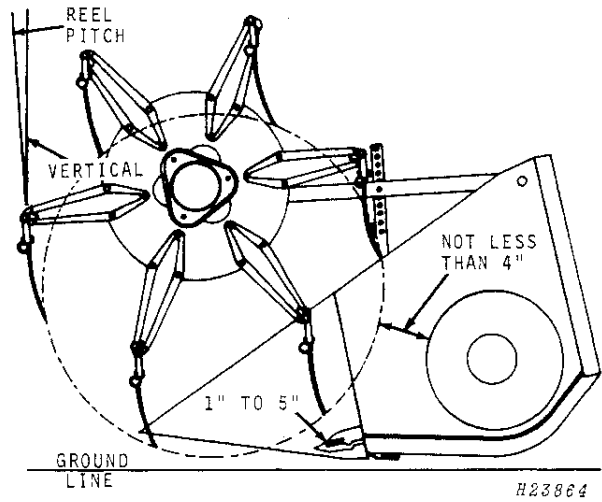

Remove adjusting screw from each side of reel and move reel forward for more pitch or rearward for less pitch as illustrated in left-hand column.

Start reel with a pitch of about 5 degrees. In grain crops, the fingers should be perpendicular to cutterbar. Too great a pitch causes reel to carry the cut crop around the reel because fingers do not release cut crop after it is cut.

MANUAL LIFT REEL

Height Adjustment

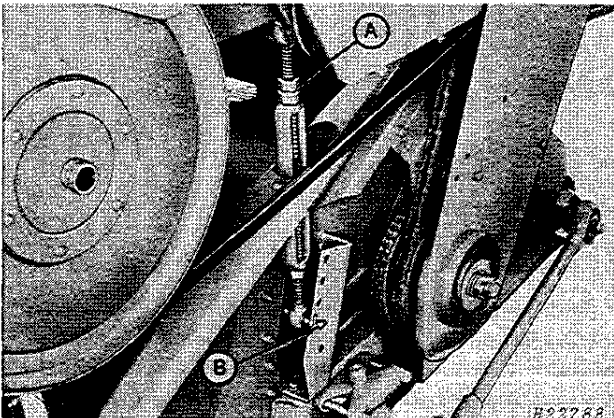

Reel arm turnbuckles, located at each end of cutting platform, are used to adjust the reel up or down. Loosen lock nut "A," turn turnbuckle, and tighten lock nut "A."

CAUTION: The reel arm is heavy and must be supported when removing pin.

The reel can also be adjusted by removing pin "B" and positioning to desired height.

NOTE: Be certain to keep reel parallel with the cutterbar to insure even feeding of material.

HYDRAULIC LIFT REEL

Raising and Lowering

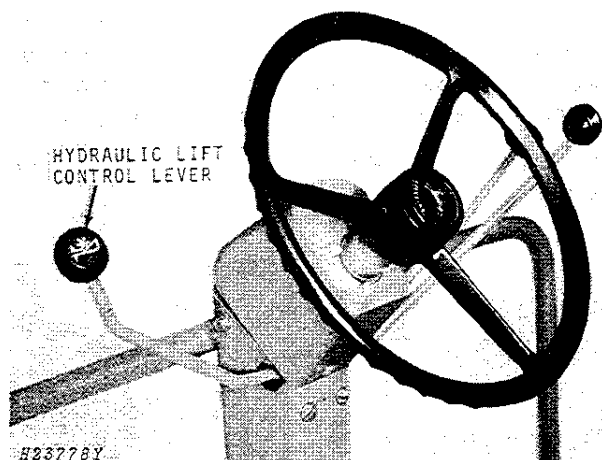

The hydraulic lift reel attachment enables the operator to control the height of the reel from the operator's platform.

The hydraulic lift reel is controlled by a lever on the left-hand side of the steering column.

To raise the reel, move the lever rearward. To lower the reel, move the lever forward. The lever automatically returns to neutral when released.

Speed of Lowering

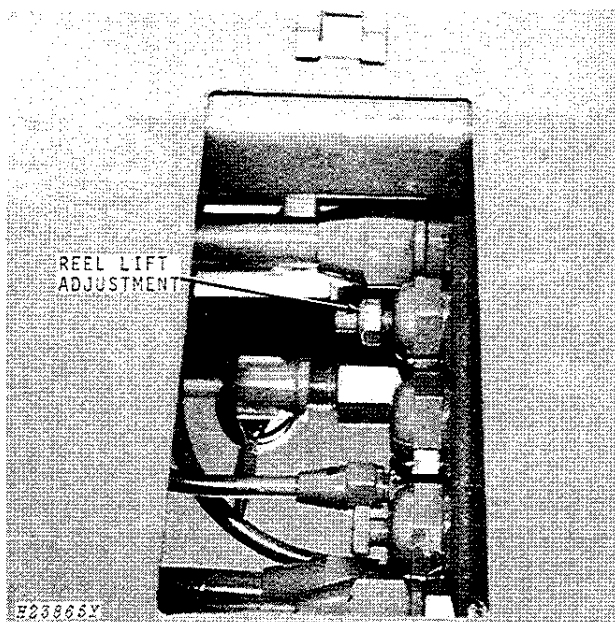

Access Plate in Floorboard Removed

The control valve, located under the operator's platform, has an adjustment to control speed of reel lowering. A nut located on the valve, can be turned in or out to change spool travel. By turning nut in, lower-

ing speed is decreased; by turning nut out, lowering speed is increased.

Height Range

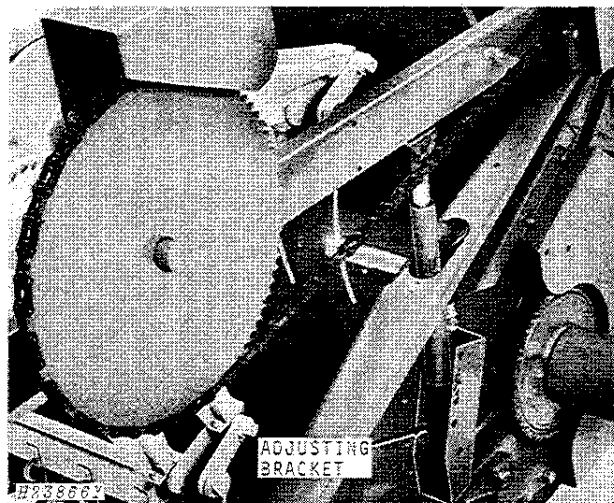

The height range of the reel is determined by the location of the bottom of the hydraulic cylinders in the adjusting brackets. Select the range that is right for the crop being harvested. Be certain that both cylinders are adjusted alike or the reel will not be level with the cutterbar.

IMPORTANT: When the hydraulic cylinders are completely retracted, be certain that the reel slats or fingers (pickup reel) do not strike the cutterbar.

Leveling

Always keep the reel level with the cutterbar. Be sure both hydraulic cylinders are located in the same hole in each adjusting bracket as explained above.

If, during operation, one end of the reel is lower than the other, raise the reel to its highest position or lower the reel to its lowest position. When both hydraulic cylinders are completely extended or retracted, the reel can then be returned to its original position and it will automatically be level.

If the reel cannot be leveled by extending or retracting the hydraulic cylinders as explained above, air may be trapped in the system. To bleed air from the hydraulic system at the slave cylinder, see page 12.

REGULAR DRIVE REEL

Reel Speeds

Reel speed may be changed by positioning the drive chain on different combinations of drive sprockets on the auger shaft and driven sprockets on the countershaft. When changing the reel speed, always position the drive chain on the inside sprocket on the auger shaft. The two auger shaft sprockets are interchangeable to insure correct drive chain alignment

(page 7). The countershaft sprockets also must be positioned correctly (page 7).

Whenever the 47-tooth sprocket is used on the auger shaft, the front support bracket for the shield will have to be repositioned as shown below.

NOTE: Shields have been removed for illustrative purposes.

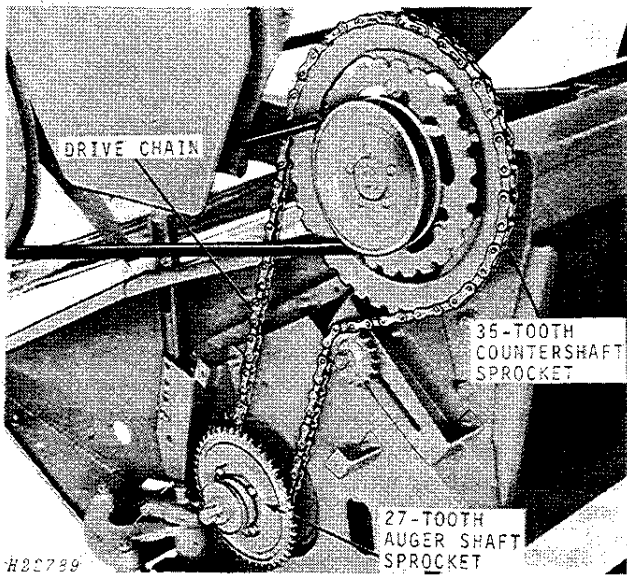

26 rpm

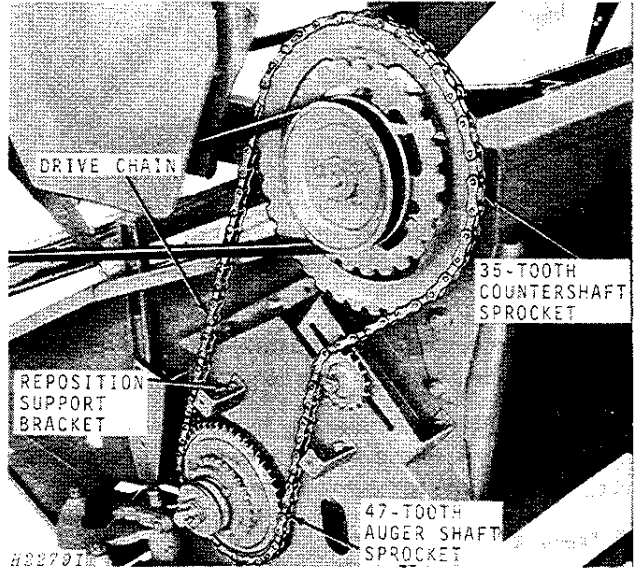

46 rpm

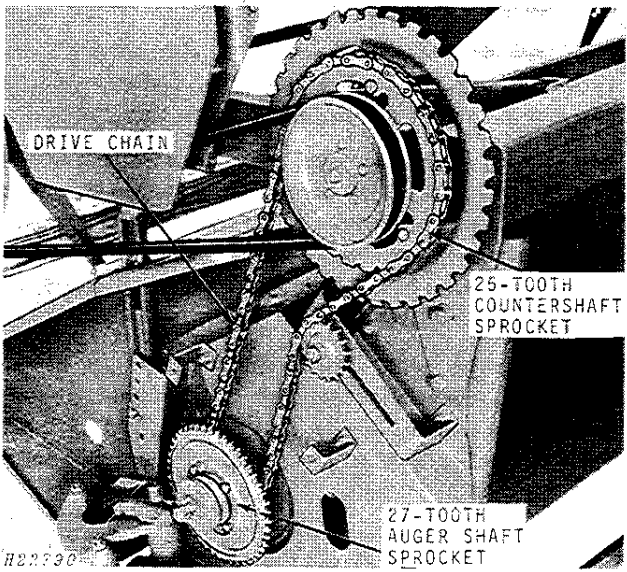

36 rpm

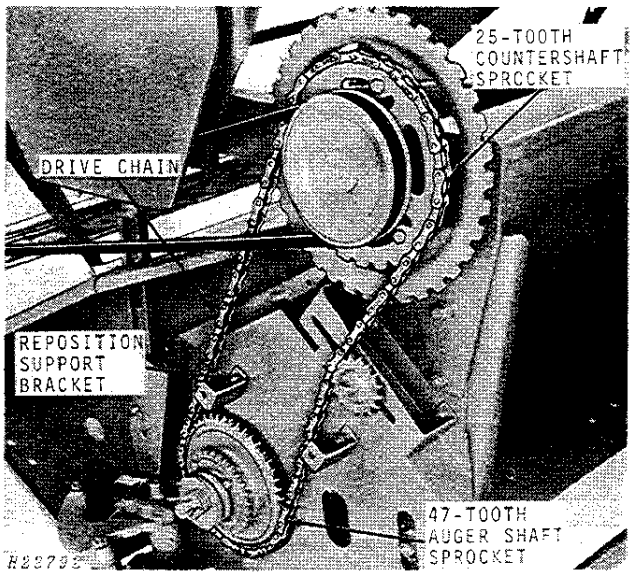

63 rpm

Interchanging Auger Shaft Sprockets

1. (Not Illustrated) Remove reel drive shield and drive chain.

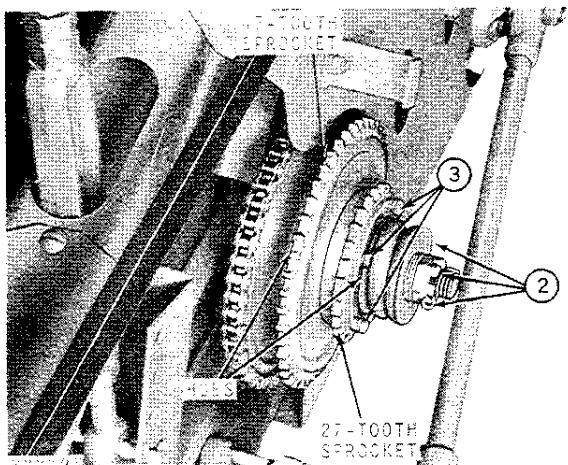

2. Remove cotter pin, castellated nut, and cup washer.

3. Remove four cap screws and slide both sprockets off the auger shaft.

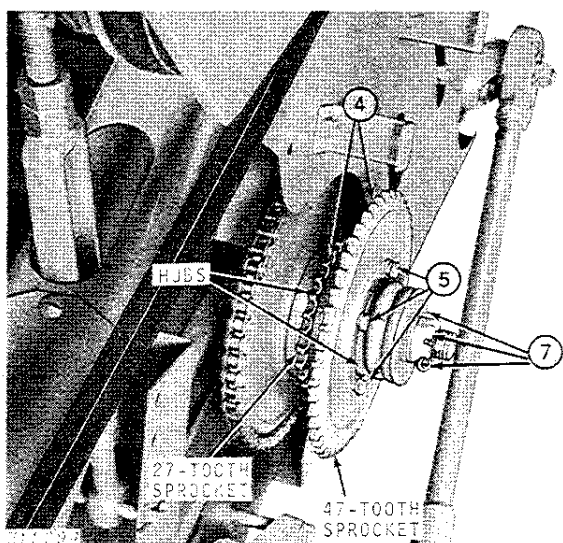

4. Slide the desired sprocket on the shaft first with the wide hub in; then slide second sprocket on with the wide hub out.

5. Install cap screws and tighten.

6. (Not illustrated) Install drive chain (add or remove chain links as necessary) and adjust tension (page 18).

7. Install cup washer, castellated nut, and cotter pin. Install reel drive shield.

Repositioning Countershaft Sprockets

1. (Not Illustrated) Remove reel drive shield and drive chain.

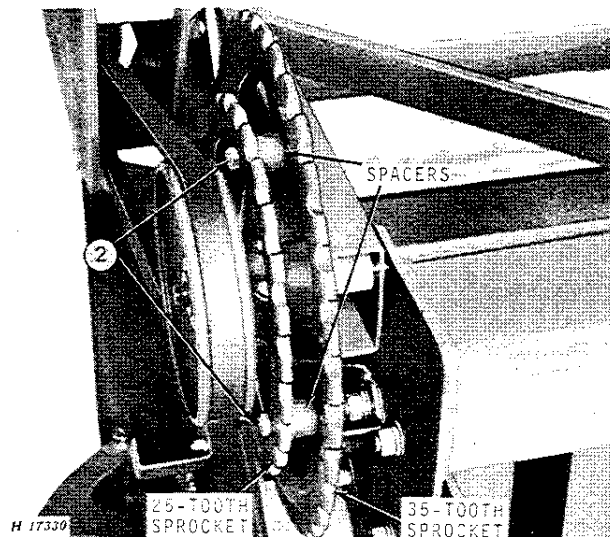

2. The illustration above shows the 25-tooth sprocket in drive position. To switch to the 35-tooth sprocket, remove three cap screws and spacers between the two sprockets.

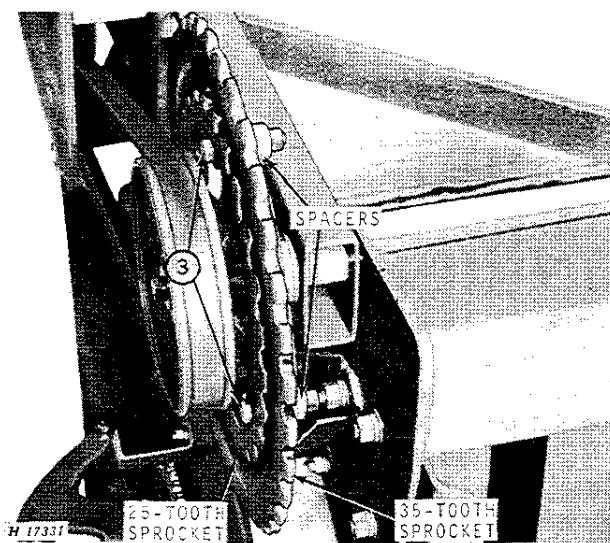

3. Install cap screws with the spacers on the back side of the 35-tooth sprocket. Tighten cap screws.

4. (Not illustrated) Install drive chain (add or remove links as necessary) and adjust tension (page 18). Install reel drive shield.

5. When returning to the 25-tooth sprocket, reposition the spacers between sprockets.

HYDROSTATIC DRIVE REEL

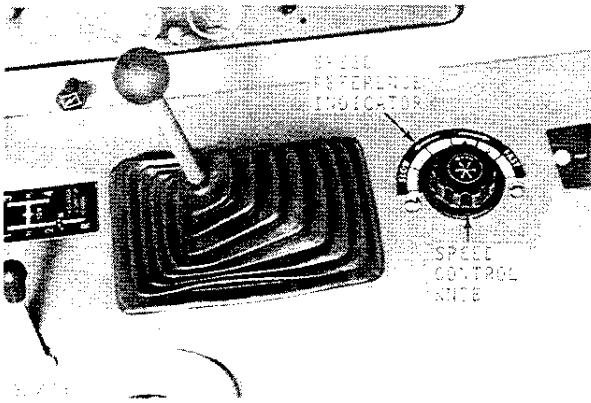

The hydrostatic drive reel attachment enables the operator to vary the speed of the reel without leaving the operator's platform.

The reel speed may be changed from 5 rpm to 40 rpm with a pickup reel or from 8 rpm to 64 rpm with a bat reel by turning the control knob on the console.

To increase the reel speed, turn the knob toward FAST. To decrease the reel speed, turn the knob toward SLOW.

Use the reference indicator as a guide to return to the reel speed that was previously found best for a particular crop or field condition.

PLATFORM AUGER

A 1/8- to 5/8-inch clearance between the auger flights and platform bottom and between the auger flights and the auger stripper is required for most crops and conditions to get smooth even feeding.

If the auger is too high or does not have the same relationship at both ends, material will be carried around the auger and will not be fed properly to the feeder conveyor.

It may be necessary to raise the auger when combining coarse stemmed crops or heavy windrows.

Adjusting Auger Height

On right-hand side of platform, loosen two nuts "A." To raise the auger, loosen nut "B" and tighten nut "C." To lower the auger, loosen nut "C" and tighten nut "B."

On the left-hand side, loosen nuts "A" and nut "B." To raise the auger, tighten bolt "C." To lower the auger, loosen bolt "C." Tighten nut "B" and nuts "A."

IMPORTANT: Keep auger level; be certain there is ample clearance for the auger fingers and proper clearance between auger flights and stripper. Check drive chain tension.

Adjusting Auger Forward and Rearward

On right-hand side of platform, loosen the two bolts "D" in the adjusting bracket. Move auger to the necessary position, and tighten nuts.

NOTE: Be careful not to destroy finger height setting.

On left-hand side, move the auger rearward by loosening nut "D" and tightening nut "E." Move the auger forward by loosening nut "E" and tightening nut "D."

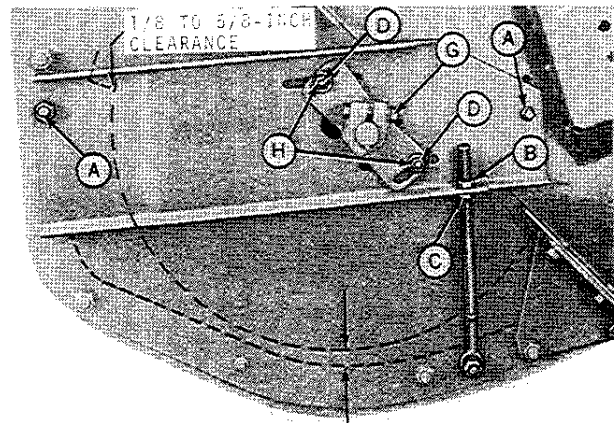

H 17337

1/8 TO 5/8-INCH
CLEARANCE

Right-Hand Side

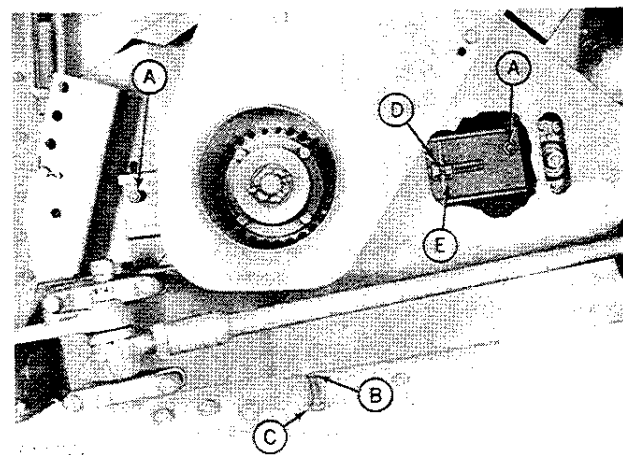

Left-Hand Side

Adjusting Finger Clearance

Retracting auger fingers are adjustable to obtain the best delivery to the feeder conveyor.

Maintain equal clearance between both the end finger bearings and the finger cranks, as illustrated. Loosen lock nuts "F" and "G" and move shaft in or out as necessary. Then secure shaft in position by tightening lock nuts "F" and "G."

Adjusting Finger Height

On the right-hand side of the platform, loosen the two bolts "H." To move the extended fingers down on the auger tube, pivot the top of bracket forward. Tighten nuts "H." Fingers must clear platform bottom 1/8 to 1/4 inch. To move fingers up, reverse the procedure.

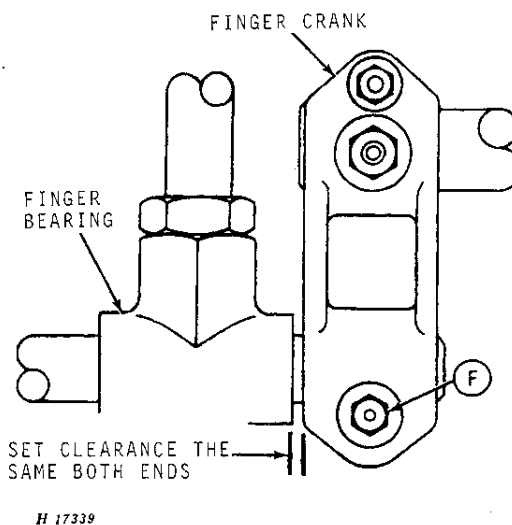

NOTE: Be careful not to destroy the auger forward and rearward adjustment.

OPERATING SPEEDS

Description	Speed	Page
Reel	26 - 63 rpm	6
Knife	465 cycles per min.	15
Knife and Platform Countershaft: 3300, 4400, 6600, and 7700 Combines	465 rpm	--
45, 55, 95, and 105 Combines	470 rpm	--
Platform Auger	205 rpm	8

SAFETY SUGGESTIONS

⚠ Study these suggestions carefully and insist that they be followed by those working with you and for you.

All machinery should be operated only by responsible persons who have been delegated to do so.

Never clean, oil, or adjust the platform when it is running.

Clothing worn by operator should be fairly tight and belted. Loose jackets, shirts, or sleeves should never be worn because of the danger of getting into moving parts.

Make certain everyone is clear of the combine before starting the combine engine so no one can be struck by moving parts.

Always disengage drive and shut off the combine engine before working on the platform.

Be certain shields and guards are in place and in good condition before starting in the field.

Never attempt to clear obstructions off the platform unless the combine is stopped and the combine engine is shut off.

Escaping hydraulic fluid under pressure can have sufficient force to penetrate the skin, causing serious personal injury. Before disconnecting lines, be sure to relieve all pressure. Before applying pressure to the system, be sure all connections are tight and that lines, pipes, and hoses are not damaged. Fluid escaping from a very small hole can be almost invisible. Use a piece of cardboard or wood, rather than hands, to search for suspected leaks.

If injured by escaping hydraulic fluid, see a doctor at once. Serious infection or reaction can develop if proper medical treatment is not administered immediately.



Lubrication and Periodic Service

SYMBOLS



Lubricate Every 5 Hours of Operation with John Deere Multi-Purpose Lubricant or an equivalent SAE Multipurpose-Type Grease.



Lubricate Every 10 Hours of Operation with John Deere Multi-Purpose Lubricant

or an equivalent SAE Multipurpose-Type Grease.



Oil Every 50 Hours of Operation with SAE 30 Oil.

LUBRICATE AS REQUIRED

CAUTION: Never lubricate or service platform while combine engine is running.

Chains

Lubricate chains at frequent intervals with SAE 30 oil. Operate chains for several minutes so they are warm when oil is applied.

NOTE: Genuine John Deere Chain Lube in an aerosol can (part number PT508) may be obtained from your John Deere dealer. This is an ideal lubricant for roller drive chains.

Knife

The amount of lubricant to use on a knife depends on the conditions in which the work is being done. When the grain is being topped and the cutterbar is carried some distance from the ground, liberal lubrication with SAE 30 oil is permissible. In conditions where the cutter bar must operate close to the ground, it is better not to use oil except for a small amount on the knife holders.

KEEP LUBRICANTS CLEAN!

Use only high-grade lubricants which have been stored in clean containers. Wipe away all grease and dirt from grease fittings before lubricating.

5-HOUR SERVICE

Slat Reel Pipe or Pick-Up Reel Shaft Housing—Both Sides

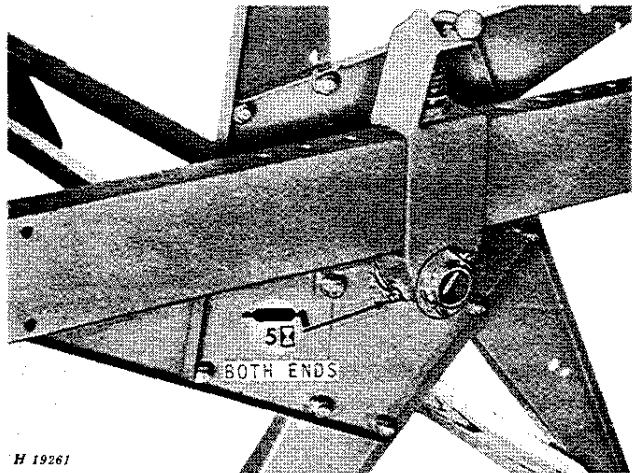

Slat Reel

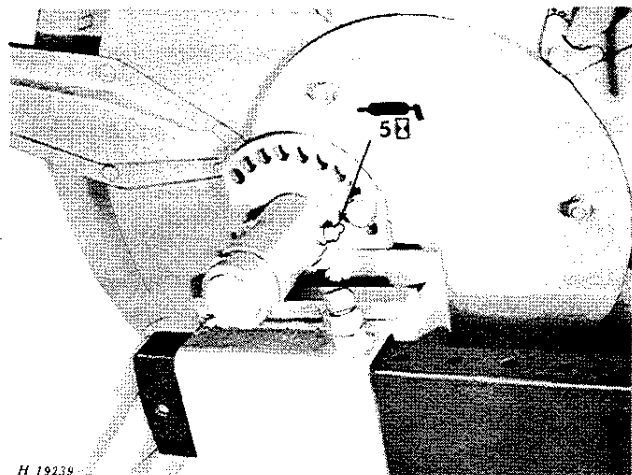

Pick-Up Reel

10-HOUR SERVICE

Perform all 5-hour lubrication.

Knife Drive Pitman, Bell Crank, and Knife Head

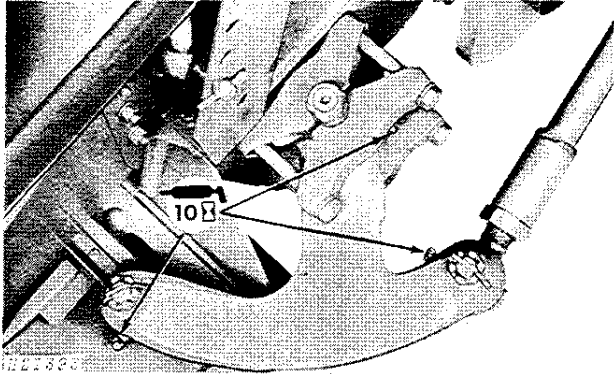

Reel Drive

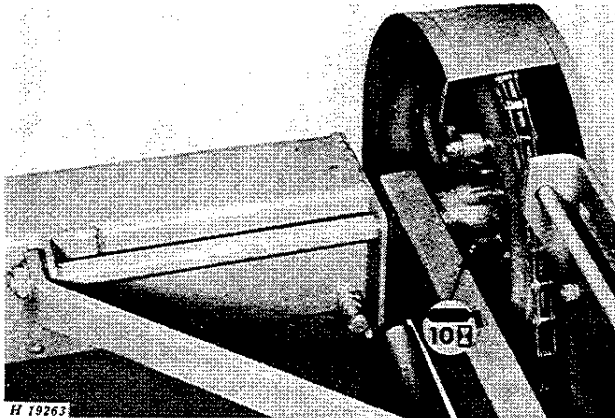

Reel Drive Belt

Check tension, page 18.

Reel Drive Chain

Check tension, page 18.

Platform Auger Drive Chain

Check tension, page 18.

50-HOUR SERVICE

Perform all 5- and 10-hour lubrication and periodic services.

Pickup Reel Finger Coils

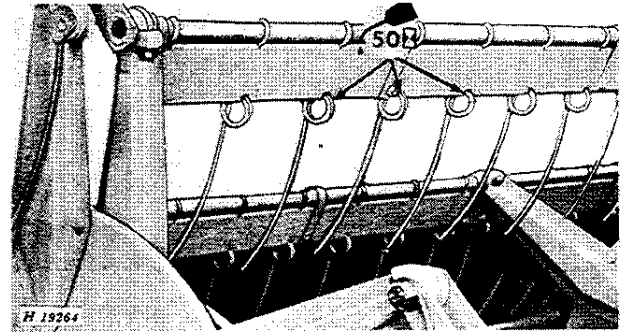

Cutterbar and Knife

- Check for broken sections, page 15.
- Check register, page 15.
- Check alignment, page 17.
- Check guards, page 15.
- Check knife clips, page 16.
- Check wearing plates, page 16.

100-HOUR SERVICE

Perform all 5-, 10-, and 50-hour lubrication and periodic services.

Platform

Check level, page 19.

Bell Crank

Check adjustment, page 14.

500-HOUR OR YEARLY SERVICE

Perform all 5-, 10-, 50- and 100-hour lubrication and periodic services.

Platform Auger Slip Clutch

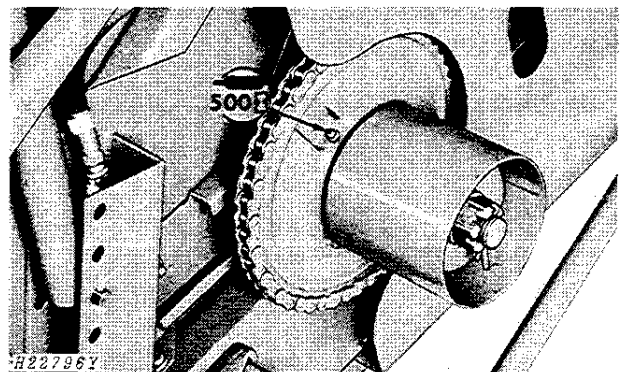

Remove pipe plug and install grease fitting. After lubrication, reinstall pipe plug to prevent more frequent lubrication of slip clutch.



Service

HYDRAULIC LIFT REEL

Bleeding the System

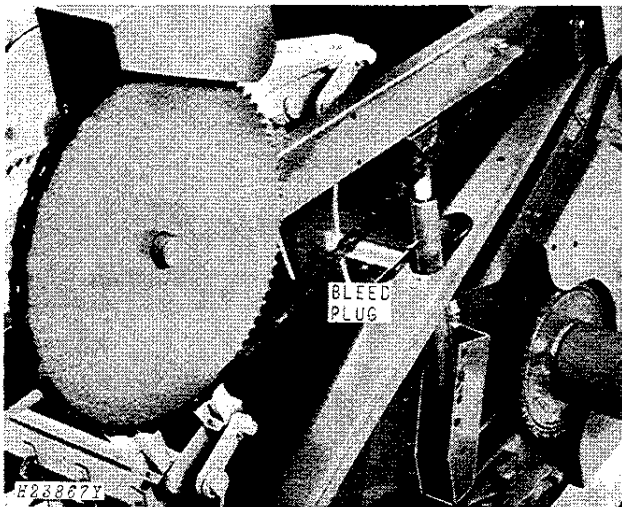

If the hydraulic hoses have been disconnected from the cylinder or if the reel will not remain level with the cutterbar, all trapped air must be removed from the cylinders and lines.

To remove trapped air, open the bleed plug at the upper end of the slave cylinder on the left-hand side of the cutting platform. Then, raise the reel. When oil flowing out the bleed plug opening is free of air bubbles, replace the bleed plug.

IMPORTANT: Be certain that the bleed plug is tight.

Control Valve

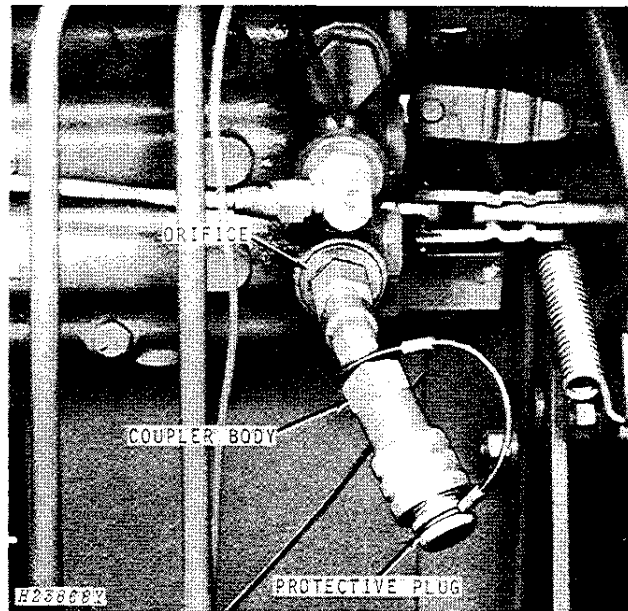

If for any reason, the coupler assembly is removed from the control valve, be sure the smooth side of the orifice is against the adapter when reinstalling adapter into control valve.

Connecting and Disconnecting Hoses

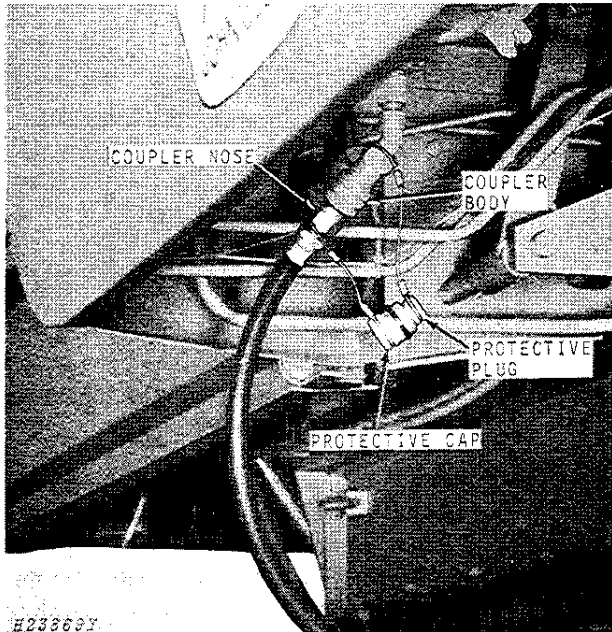

When the hydraulic hose is connected to control valve, snap protective cap and plug together as shown above.

Whenever the hydraulic hose is disconnected from control valve, be sure to insert protective plug into coupler body as shown in illustration at bottom of page 12 and snap protective cap over coupler nose.

HYDROSTATIC DRIVE REEL

Tightening Pump Drive Belt

3300 and 4400 Combines

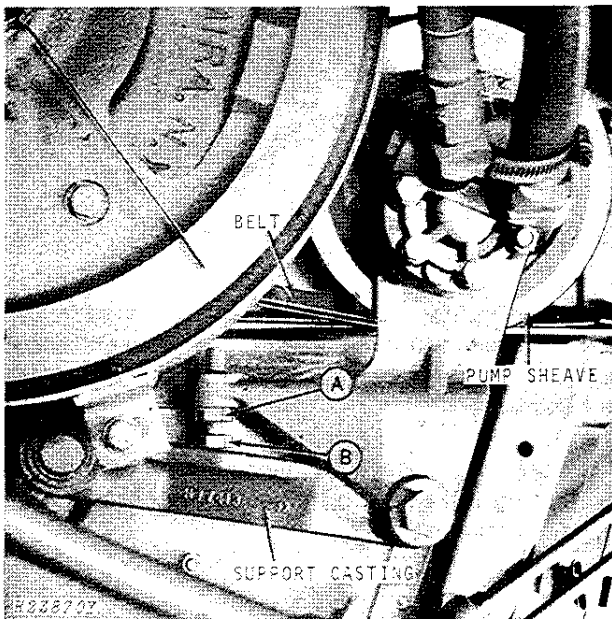

- Loosen lock nut "A."
- Turn cap screw "B" out against support casting, forcing pump sheave against belt.
- Tighten belt until it will operate without slipping.
- Tighten lock nut "A."

IMPORTANT: Keep this belt tight at all times.

6600 and 7700 Combines

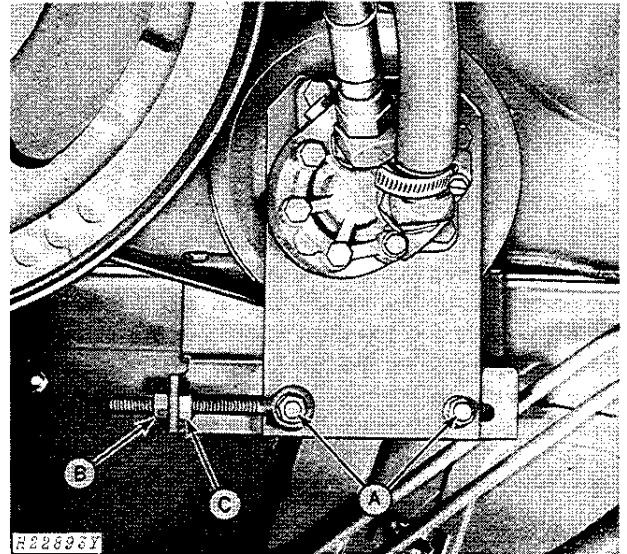

- Loosen nuts "A" and nut "B."
- Turn nut "C" until belt will operate without slipping.
- Tighten nut "B" and nuts "A."

IMPORTANT: Keep this belt tight at all times.

Tightening Reel Drive Chain

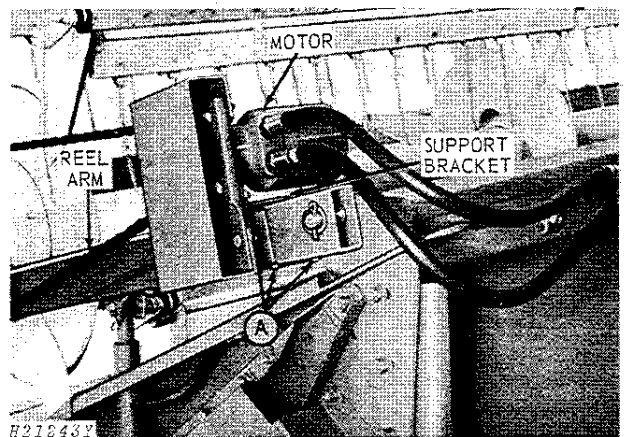

- Loosen four carriage bolts "A."
- Pull motor and support bracket rearward on reel arm until the chain will operate without climbing or jumping sprocket teeth.
- Tighten carriage bolts "A."



Suggest:

If the above button click is invalid.

Please download this document

first, and then click the above link

to download the complete manual.

Thank you so much for reading

Connecting Hoses

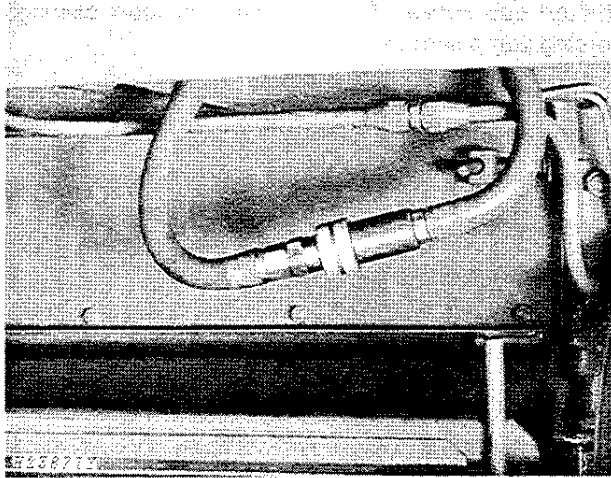

IMPORTANT: When the hoses are disconnected from the oil lines to the motor, be sure to connect the pressure line to the return line at the combine as shown to assure a free flow of fluid to the reservoir. Failure to provide for the return flow will result in constant operation of the relief valve which will eventually overheat and damage the hydraulic system.

HYDRAULIC CYLINDER SAFETY STOP

CAUTION: When working under the platform always place the hydraulic cylinder safety stop in safety position.

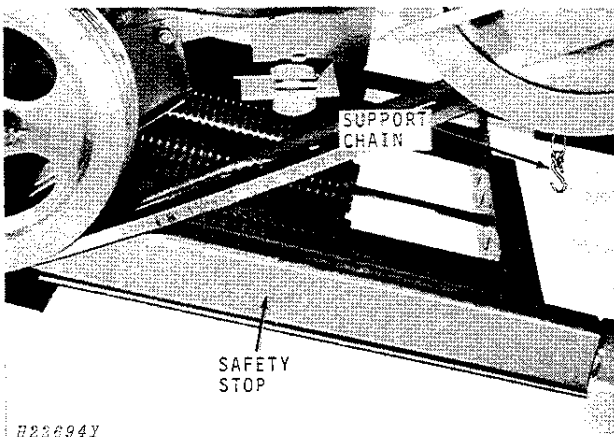

Safety Position

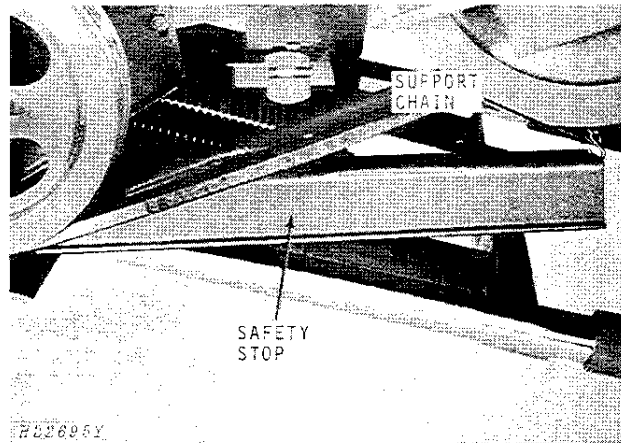

Storage Position

To place hydraulic cylinder safety stop in safety position first extend hydraulic cylinders. Disconnect support chain from safety stop and position safety stop on piston rod. After completing the work on the platform, attach safety stop to support chain for storage.

CUTTERBAR

Bell Crank Bearing Adjustment

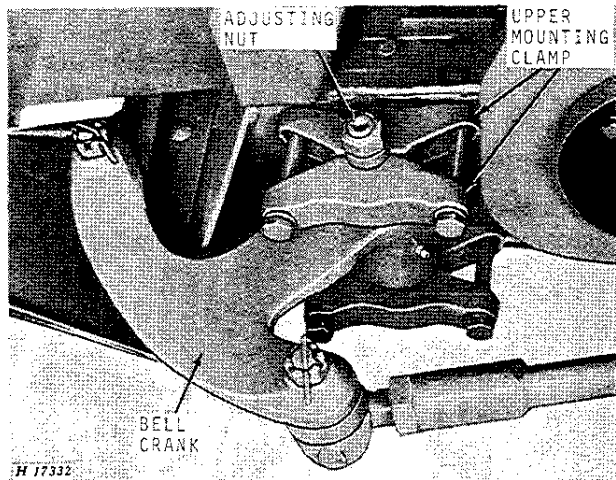

Check the tapered roller bearing (located in bell crank) every 100 hours of operation for vertical end play. If vertical end play exists, make the following adjustments:

Loosen top bolts in mounting clamp and tighten adjusting nut until end play disappears; tighten mounting clamp bolts.

<https://www.ebooklibonline.com>

Hello dear friend!

Thank you very much for reading.

Enter the link into your browser.

The full manual is available for immediate download.

<https://www.ebooklibonline.com>