

# JOHN DEERE COMBINE OPERATOR'S CAB AND ACCESSORIES



## OPERATORS MANUAL JOHN DEERE COMBINE OPERATOR'S CAB AND ACCESSORIES

OMH84015 K1 English

JOHN DEERE HARVESTER WORKS  
OMH84015 K1

LITHO IN THE U.S.A. (REVISED)  
ENGLISH





## To The Purchaser

---

This new operator's cab was carefully designed and manufactured to give years of dependable service. To keep it running efficiently, read the instructions in this operator's manual. Each section is clearly identified so you can easily find the information you need—whether it is operation or service. Read the Table of Contents to learn where each section is located.

 This safety alert symbol identifies important safety messages in this manual. When you see this symbol, be alert to the possibility of personal injury and carefully read the message that follows.

Study this manual carefully, keep it handy with your regular combine operator's manual, in a safe place, for future reference.

If you find that you require information not covered in this manual, see your John Deere dealer. He will answer any questions regarding the operation and service of the operator's cab. He has trained mechanics who are kept informed on the best method of

John Deere servicing and can give you prompt know-how service in the field or in his shop.

Should your operator's cab require replacement parts, see your John Deere dealer where you will receive John Deere parts—accept no substitutes. John Deere parts fit properly and insure satisfactory service because they are made from original patterns and from the same material as the new machines.

"Right-hand" and "left-hand" sides are determined by facing in the direction the combine will travel when in use.

The warranty on this operator's cab appears on your copy of the purchase order which you should have received from your dealer when you purchased the operator's cab.

Record the date purchased in the space provided on page 18. Your dealer needs this information to give you prompt, efficient service when you order parts.

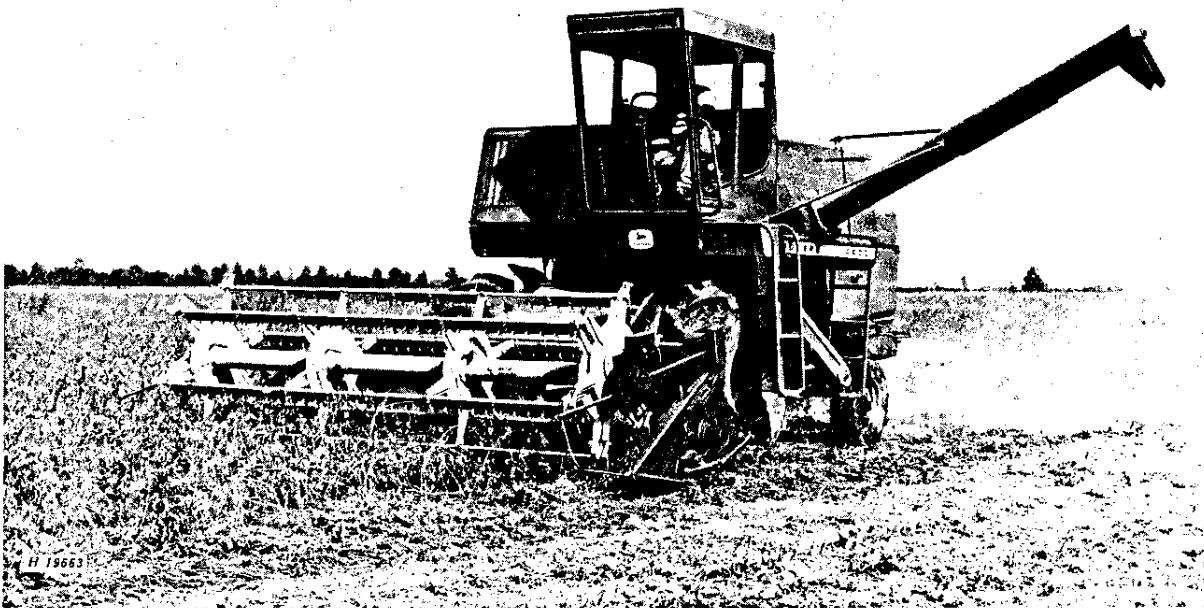



# Contents

	Page
Operation .....	2
Controls .....	2-3
Pressurizer System .....	3
Heater System .....	5
Air Conditioner System .....	4-5
End-of-Season Service .....	6
Pre-Season Service .....	6
Service .....	7-11
Wiring Diagrams .....	10-11
Trouble Shooting .....	12-16
Specifications .....	17-18

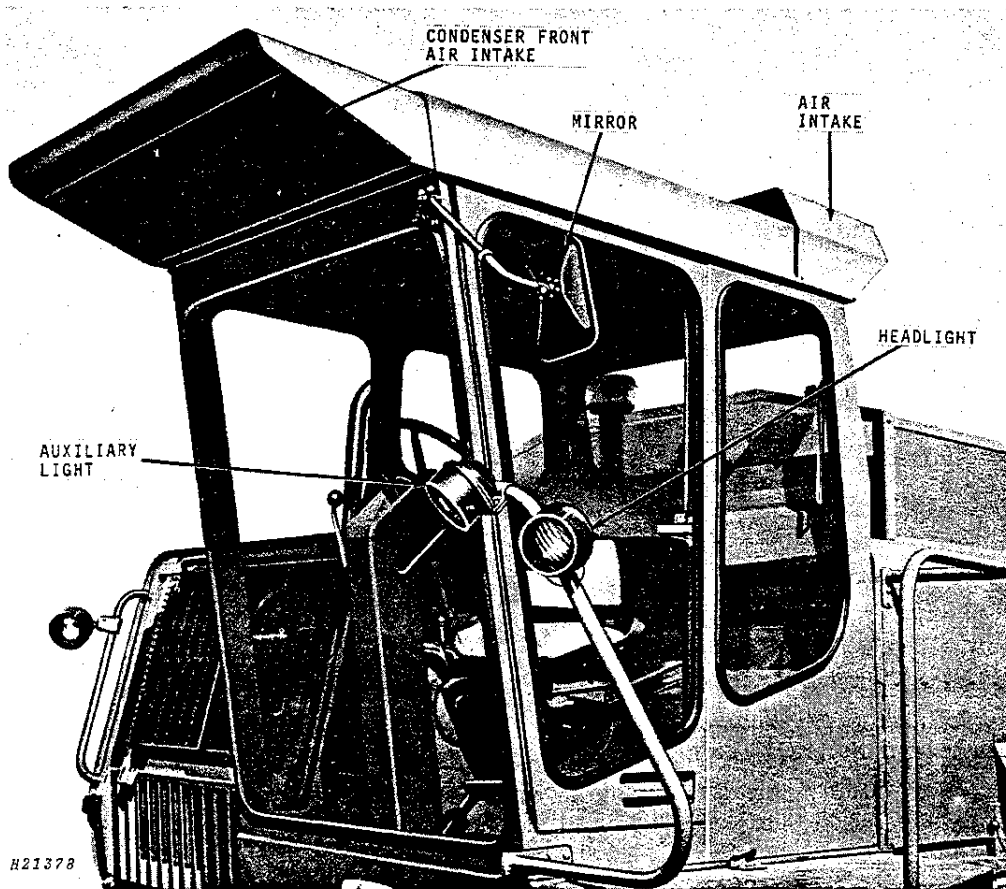

John Deere Combine Operator's Cab

**<https://www.ebooklibonline.com>**

Hello dear friend!

Thank you very much for reading.

Enter the link into your browser.

The full manual is available for immediate download.

**<https://www.ebooklibonline.com>**



# Operation

## CONTROLS

The operator's cab controls are conveniently located in the cab headliner to the front and side of the operator. The radio is located in the rear right-hand corner of the cab.

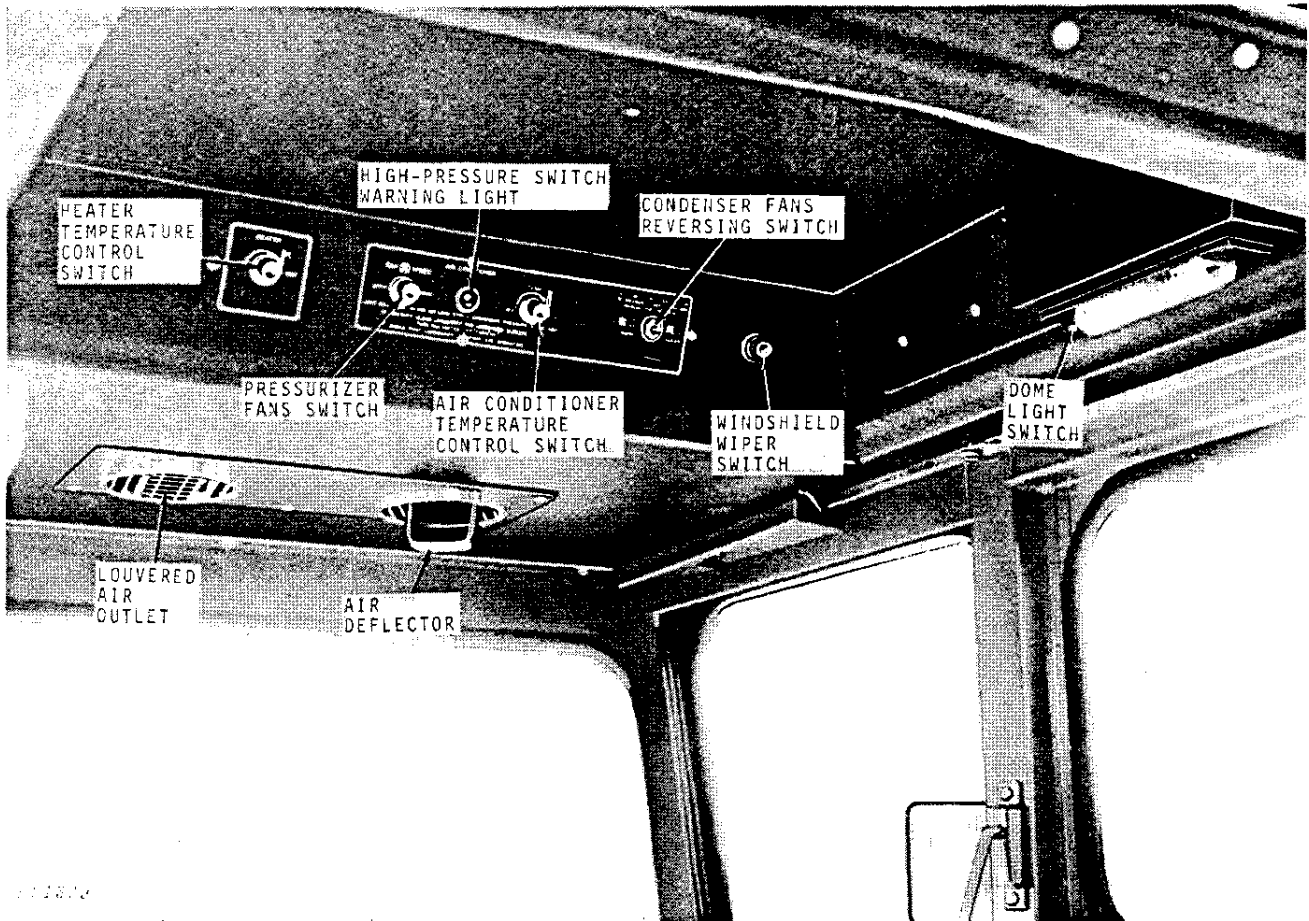

### Heater Temperature Control Switch

The amount of heat in the cab is controlled by turning the heater control switch clockwise, from the "OFF" position toward the "HOT" position. Turning the switch all the way to the "HOT" position will provide maximum heating.

### Pressurizer Fans Switch

This switch controls the fans which pressurize the cab. This is a three-speed switch with the highest speed obtained by turning the switch clockwise as far as it will go.

**IMPORTANT:** Pressurizer fans must be operating whenever the heater or air conditioner is in use.

### High-Pressure Switch Warning Light

This light will glow red when the high-pressure switch has activated indicating that it may be necessary to clean the condenser. See page 9.

### Air Conditioner Temperature Control Switch

The air conditioner temperature control switch is a thermostatic-type switch which will maintain the desired temperature.

Cool air in the cab is controlled by turning the air conditioner temperature control switch from the "OFF" position clockwise toward the "COLD" position. Turning the switch all the way to the "COLD" position will provide maximum cooling.

### Condenser Fans Reversing Switch

When pushed to the right, this toggle-type switch will reverse the three condenser fans located in the cab roof. When released, it will automatically return to normal operating position.

**IMPORTANT:** Operate this reversing switch once every grain tank load for approximately 30 seconds, to clean the condenser core of any dirt or chaff.

### Windshield Wiper Switch

This is a two-speed switch. Turning the switch clockwise to the first detent will give normal wiper operation. The second detent position will produce a faster wiper action. When the switch is turned all the way counterclockwise, the wiper will return to its stop position.

### Dome Light Switch

Moving this toggle-type switch to the right turns the dome light on; moving this switch to the left turns the light off.

### Louvered Air Outlets

The air outlets are adjustable, enabling the operator to control the flow of air into the cab. The outlets can be turned 360 degrees. One of the air outlets is equipped with an air deflector to further control air flow.

### PRESSURIZER SYSTEM

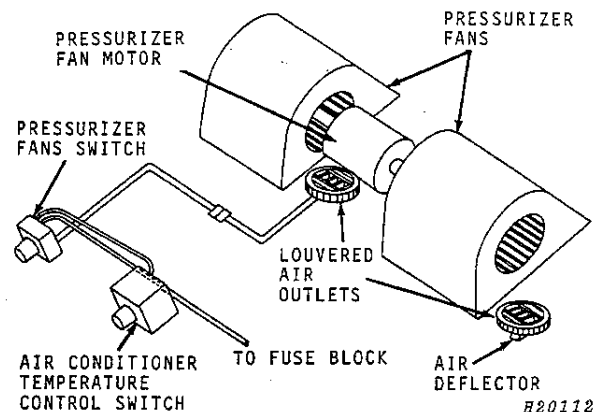

The pressurizer system is made up of two rotating cage-type fans, an electric motor, two louvered air outlets, an air deflector (snapped into one of the air outlets) and a control switch.

The pressurizer fans, when activated by the control switch, increase the pressure inside the cab. With a higher pressure inside the cab, the air and dust will not move from outside the cab to the inside of cab.

The louvered air outlets are also used to direct air flow from the air conditioner and heater.

**IMPORTANT:** The pressurizer system must be in operation when the air conditioner or heater is in use.





**Suggest:**

**If the above button click is invalid.**

**Please download this document**

**first, and then click the above link**

**to download the complete manual.**

**Thank you so much for reading**

### High-Pressure Switch

The high-pressure switch is used in conjunction with a relay to prevent the compressor electromagnetic clutch from recycling when a head pressure of 400 psi or above is reached.

Indications that the high-pressure switch has been activated are as follows:

1. Compressor and condenser fans not operating.
2. No cooling even though pressurizer fan is working.
3. High-pressure switch warning light glows red.

To reactivate the system after the high-pressure switch has been activated, turn the pressurizer fan switch off and then on. If, after a short time, the high-pressure switch is again activated; the condenser needs to be cleaned. See page 9.

### High-Pressure Switch Warning Light

This light warns the operator that the high-pressure switch has activated as described above.

### Refrigerant-Loss Switch

The refrigerant-loss switch senses low pressure in the air conditioner system caused by loss of refrigerant or when operating in temperatures below 25°F. When the refrigerant-loss switch activates, the entire air conditioner system is inoperative.

See your John Deere dealer and have him charge the system.

### Maximum Air Recirculator

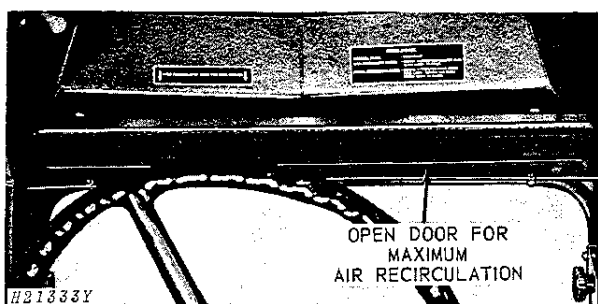

Under normal operating conditions, the normal air recirculator will provide sufficient cooling.

In those conditions which require increased cooling, open the door on the maximum air recirculator at the rear of cab.

### HEATER SYSTEM

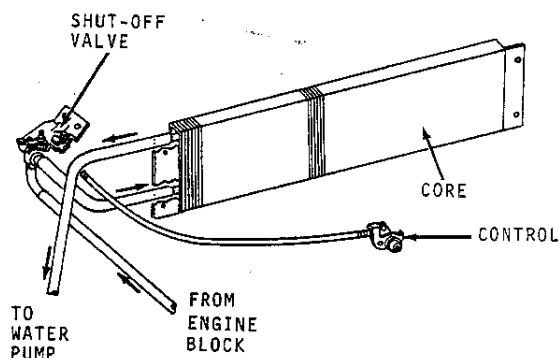

H20113

The heater system is composed of a core, a mechanical shut-off valve, hoses, and a control.

With the control knob on, the shut-off valve allows coolant from the engine block to enter, the shut-off valve directs the coolant to the lower tube of the core, and the water moves through the core out the upper tube on the core to the water pump.

The pressurizer fans blow across the heater core as the coolant moves through the heater, removing heat and blowing it through the louvered air outlets into the cab.

**IMPORTANT:** The pressurizer system must be in operation when the heater is in use.

### SAFETY SUGGESTION

**CAUTION:** Air conditioner refrigerant is very dangerous when not handled properly. The air conditioner system should only be serviced by a qualified serviceman.

**<https://www.ebooklibonline.com>**

Hello dear friend!

Thank you very much for reading.

Enter the link into your browser.

The full manual is available for immediate download.

**<https://www.ebooklibonline.com>**