

**JOHN DEERE**  
**WORLDWIDE COMMERCIAL & CONSUMER**  
**EQUIPMENT DIVISION**

---

**Blower and Rear Hopper**  
**Dump From Seat 14 Bushel**

OMTCU29193 J0

**OPERATOR'S MANUAL**



**JOHN DEERE**

**Original Instruction**

All information, illustrations and specifications in this manual are based on the latest information at the time of publication. The right is reserved to make changes at any time without notice.

**COPYRIGHT© 2010**

**Deere & Co.**

**John Deere Worldwide Commercial and Consumer Equipment Division**

**All rights reserved**

**Previous Editions**

**COPYRIGHT©**

**North American Version**

**Litho in U.S.A.**

---

---

# INTRODUCTION

---

---

## Table of Contents

Introduction.....	1
Product Identification.....	1
Safety Labels.....	3
Safety.....	3
Preparing Vehicle.....	5
Assembly.....	9
Installing.....	16
Removing and Storing.....	19
Operating.....	21
Service Intervals.....	22
Service.....	23
Troubleshooting.....	26
Specifications.....	26
Getting Quality Service.....	26

---

---

## Introduction

### Using Your Operator's Manual

Read this entire operator's manual, especially the safety information, before operating.

This manual is an important part of your machine. Keep all manuals in a convenient location so they can be accessed easily.

Use the safety and operating information in the attachment operator's manual, along with the machine operator's manual, to operate and service the attachment safely and correctly.

If your attachment manual has a section called Preparing the Machine, it means that you will have to do something to your tractor or vehicle before you can install the attachment. The Assembly and Installation sections of this manual provide information to assemble and install the attachment to your tractor or vehicle. Use the Service section to make any needed adjustments and routine service to your attachment.

If you have any questions or concerns with the assembly, installation, or operation of this attachment, see your local John Deere dealer or call the John Deere Customer Contact Center at 1-800-537-8233 for assistance.

Warranty information on this John Deere attachment can be found in the warranty that came with your John Deere tractor or vehicle.

---

---

## Product Identification

### Product Compatibility

The 14 Bushel Dump From Seat (DFS) Material Collection System is compatible with the ZTrak models:

- Z820A, Z830A, Z840A, Z850A, Z860A
- Z920A, Z925A, Z930A, Z950A, Z960A, Z970A

# PRODUCT IDENTIFICATION

---

## Record Identification Numbers

### Blower

Serial Number (040001- )

If you need to contact an Authorized Service Center for information on servicing, always provide the product model and serial number.

You will need to locate the serial number (A) for the attachment. Record the information in the spaces provided below.



MX22809

DATE OF PURCHASE:

\_\_\_\_\_

DEALER NAME:

\_\_\_\_\_

DEALER PHONE:

\_\_\_\_\_

PRODUCT SERIAL NUMBER (A):

-----

**<https://www.ebooklibonline.com>**

Hello dear friend!

Thank you very much for reading.

Enter the link into your browser.

The full manual is available for immediate download.

**<https://www.ebooklibonline.com>**

# SAFETY LABELS

## Safety Labels



### Understanding The Machine Safety Labels

The machine safety labels shown in this section are placed in important areas on your machine to draw attention to potential safety hazards.

On your machine safety labels, the words DANGER, WARNING, and CAUTION are used with this safety-alert symbol. DANGER identifies the most serious hazards.

The operator's manual also explains any potential safety hazards whenever necessary in special safety messages that are identified with the word, CAUTION, and the safety-alert symbol.

There can be additional safety information contained on parts and components sourced from suppliers that is not reproduced in this operator's manual.

### WARNING - M118454



M118454

#### Rotating Blade -Thrown Objects

- Operate blower with entire grass catcher secured in place.

### DANGER

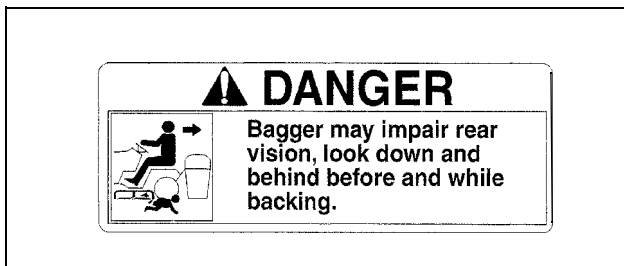

M146238

- Bagger may impair rear vision; look down and behind before and while backing.

### WARNING

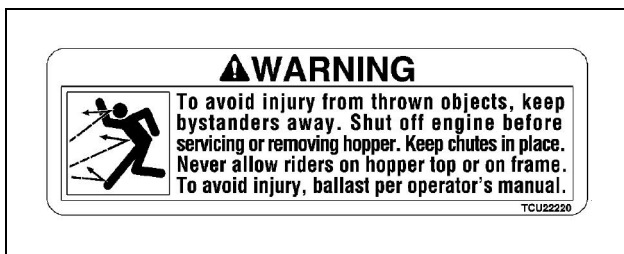

TCU22220

- To avoid injury from thrown objects, keep bystanders away. Shut off engine before servicing or removing hopper. Keep chutes in place. Never allow riders on hopper top or on frame. To avoid injury, ballast per operator's manual.

### CAUTION - TCU16753

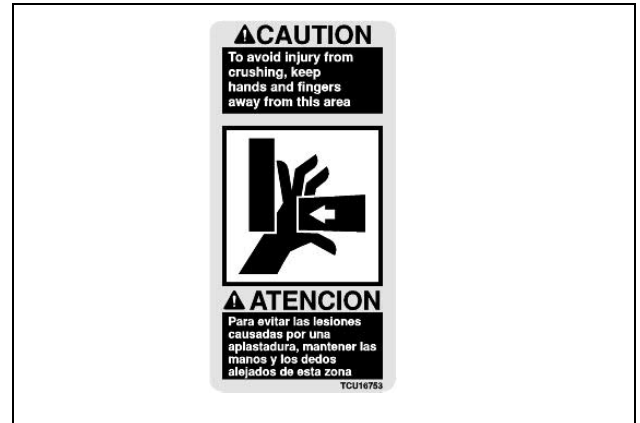

TCU16753

- To avoid injury from crushing, keep hands and fingers away from this area.

## Safety

### Read Safety in Machine Operator's Manual

Read the general safety operating precautions in your machine operator's manual for additional safety information.

### Operating Safely

Read, understand and follow all instructions in this attachment manual, the machine operator's manual and safety signs on equipment before starting. Use proper front ballast. Remove ballast when the material collection system is removed.

Hopper extends beyond machine. Be aware of surrounding objects when making short turns.

Do not operate material collection system unless entire grass catcher is fastened in place with hopper securely installed.

Do not let anyone ride on the mower or material collection system. Riders are subject to injury such as being struck by foreign objects or being thrown off. Riders may obstruct the operator's view and cause a collision.

#### Before hopper removal or installation:

- Stop mower.
- Disengage mower or PTO.
- Stop engine and remove key.
- Wait for engine and all moving parts to stop before leaving the operator seat.

#### Before backing up machine:

- Stop machine.
- Look behind hopper for children.
- Keep bystanders away when unloading material collection system.

#### Operate safely on slopes:

- Empty MCS when half full.
- Do not operate on steep slopes.
- Before turning, slow down.
- Avoid sudden starts and stops.

# SAFETY

---

- Do not park machine with material collection system on slopes.

## Hose Maintenance:

- Hose is subject to wear and deterioration.
- Check hose frequently; replace when necessary.
- Use John Deere hose or equivalent to comply with safety specifications.

## Parking Safely

1. Stop machine on a level surface, not on a slope.
2. Disengage mower blades or any other attachments.
3. Lower attachments to the ground.
4. Lock the park brake.
5. Stop the engine.
6. Remove the key.
7. Wait for engine and all moving parts to stop before you leave the operator's seat.
8. Close fuel shut-off valve, if your machine is equipped.
9. Disconnect the negative battery cable or remove the spark plug wire(s) (for gasoline engines) before servicing the machine.

## Protect Children

- Tragic accidents can occur if the operator is not alert to the presence of children. Keep children indoors when the machine and attachment are operated and under the watchful care of another responsible adult.
- Never assume that children will remain where you last saw them. Stay alert to the presence of children. Turn the machine off if a child enters the work area.
- Do not let children or an untrained person operate the machine.
- Do not carry or let children ride on any attachment or machine even with the attachment off. Do not tow children in a cart or trailer.

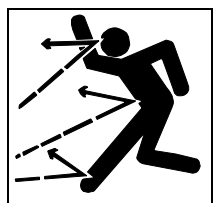

## Avoid Injury From Thrown Objects

- When operating the vehicle with the MCS attachment installed make sure all chutes and hoses are securely in place. Keep hopper closed or MCS in operating position.
- Stop the engine and wait for all moving parts to stop before removing or lifting any attachment components.

- Avoid injury from impeller blades and thrown objects. Remove attachment when operating vehicle in side discharge mode. Make sure deflector shield is in place on mower deck if attachment is removed.



## Avoid Injury From Rotating Blades

- Keep hands and feet away from rotating blades and blower assembly when engine is running.

- Stop engine and wait for moving parts to stop before servicing components.
- Do not operate MCS or blower unless all attachment components are in place and latched.

## Practice Safe Maintenance

- Only qualified, trained adults should service this machine.

- Understand service procedure before doing work. Keep area clean and dry.
- Do not operate the engine in a confined space where dangerous carbon monoxide fumes can collect.
- Never lubricate, service or adjust the machine or attachment while it is moving. Keep safety devices in place and in working condition. Keep hardware tight.
- Keep hands, feet, clothing, jewelry, and long hair away from any moving parts, to prevent them from getting caught.
- Lower any attachment completely to the ground or to an existing attachment mechanical stop before servicing the attachment. Disengage all power and stop the engine. Lock park brake and remove the key. Let machine cool.
- Disconnect battery or remove spark plug wire (for gasoline engines) before making any repairs.
- Before servicing machine or attachment, carefully release pressure from any components with stored energy, such as hydraulic components and springs.
- Release hydraulic pressure by lowering attachment or cutting units to the ground or to a mechanical stop and move hydraulic control levers.
- Securely support any machine or attachment elements that must be raised for service work. Use jack stands or lock service latches to support components when needed.
- Never run engine unless park brake is locked.
- Keep all parts in good condition and properly installed. Fix damage immediately. Replace worn or broken parts. Replace all worn or damaged safety and instruction decals.
- Check all hardware at frequent intervals to be sure the equipment is in safe working condition.
- Do not modify machine or safety devices. Unauthorized modifications to the machine or attachment may impair its function and safety.

# PREPARING VEHICLE

## Preparing Vehicle

### Verify Frame Member Reinforcement

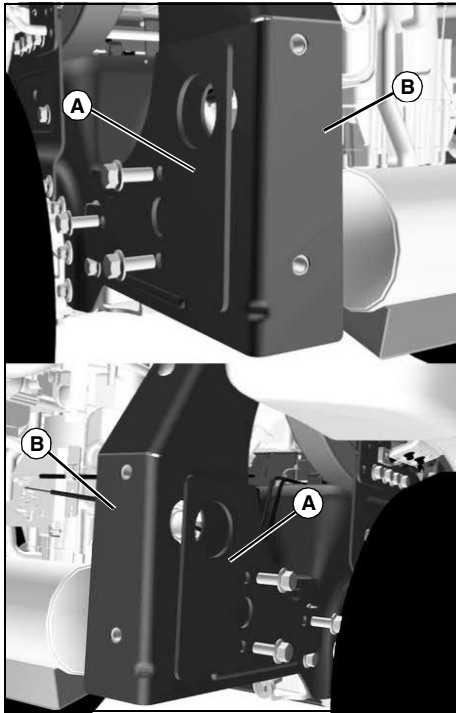

MX19962, MX2965a

The assembly section of this manual refers to the removal and installation of side plates (A) and reinforced frame members (B).

Determine if mower is equipped with reinforced frame members. If not, parts (TCA19292 and TCA19293) must be ordered and installed on mower prior to installing MCS.

- Reinforced frame members and side plates are not necessary on ZTrak Estate series.
- Reinforced frame members are factory installed on ZTrak Pro series models listed below. Removal of frame members and installation of side plates is not necessary.
  - Z810A through Z850A - serial numbers 020001 and above.
  - Z860A
  - Z900A Series
- Confirm that mower is equipped with reinforced frame members by measuring material thickness:
  - Reinforced frame members are 4.55 mm (3/16 in.) thick.
  - Non-reinforced frame members are 3.42 mm (1/8 in.) thick.

### Checking Tire Pressure

Check tire pressure of machine before installing hopper. See your machine operator's manual.

## Installing Proper Mower Blades

**IMPORTANT: Avoid damage! When replacing mower blades, always use genuine John Deere Service Parts.**

- For best performance, always use correct mower blade for job being performed.
- Always follow safety and service instructions in the machine operator's manual when changing mower blades.

For maximum performance from your material collection system (MCS), install the correct mower blades for your application:

- Mulching Blades - Not for use with MCS.
- Standard Blades - Standard blades are designed for bagging, side discharging, and all mowing conditions.

## Installing Mounting Bracket for MCS Blower

**CAUTION: Avoid injury! Rotating blades are dangerous. Before adjusting or servicing mower:**

- Disconnect spark plug wire(s) or battery negative (-) cable to prevent engine from starting accidentally.
- Always wear gloves when handling mower blades or working near blades.

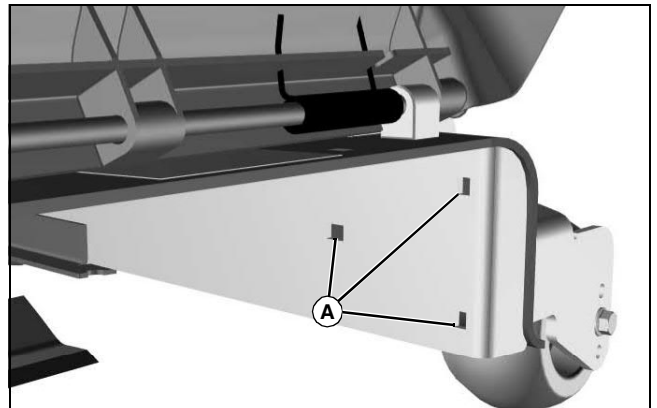

MX25142

1. Lift discharge chute up and locate mounting holes (A) for front bracket.

# PREPARING VEHICLE

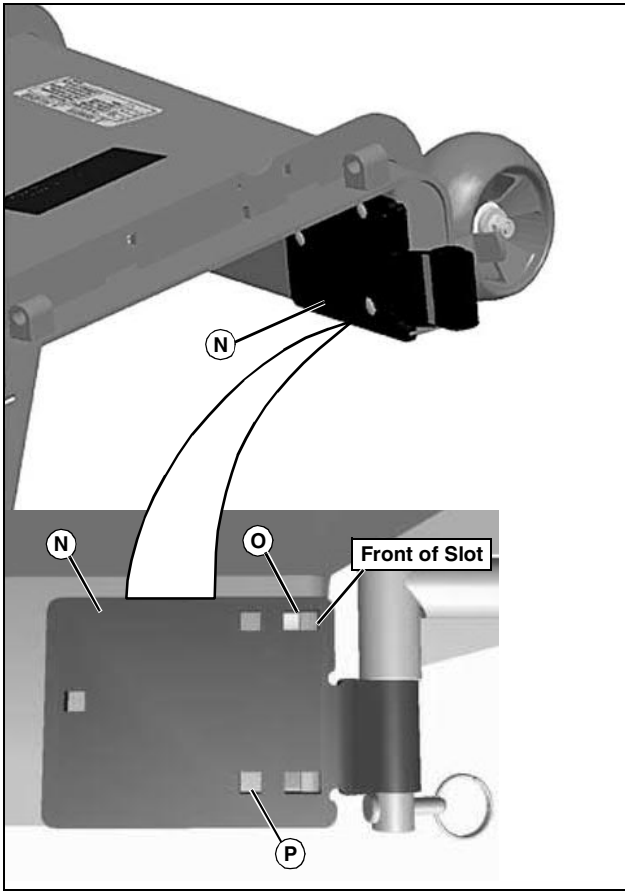

MX23678, MX22841

**Picture Note: Hardware removed for clarity. Position bracket as shown with blower pivot tube toward bottom.**

2. Position front pivot bracket (N) flush with deck.
3. Install and tighten three M8 X 25 carriage bolts and locknuts in locations listed below:
  - 48 in deck located in back of slot (O)
  - 54 in deck located in the middle of slot (O)
  - 60 in. deck is located front of slot (O).
  - 72 in. deck is location (P).

## Bracket Assembly for all Mulch on Demand Decks.

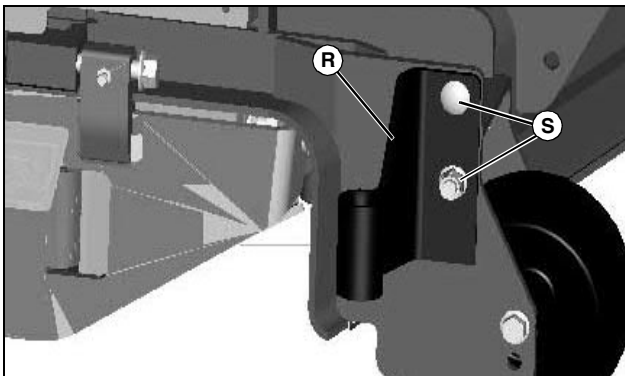

MX26037

1. Position front pivot bracket (R) flush with outside scalp wheel frame.

2. Install and two M8 X 25 carriage bolts (S) and locknuts, and secure bracket into place.

## Install Blower Support Bracket

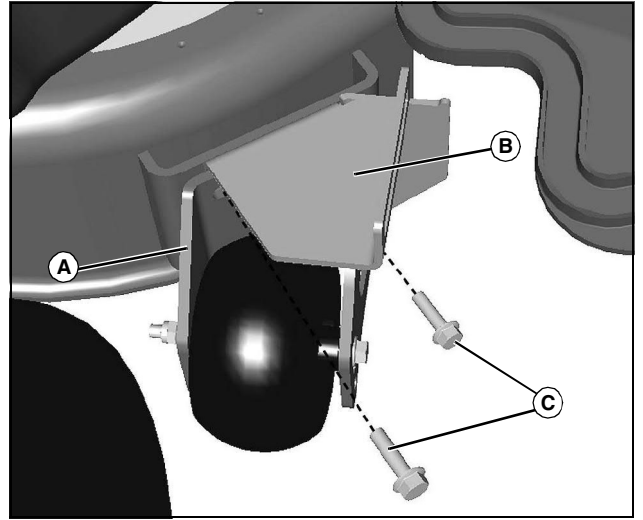

MX47240

**Picture Note: Z800/Z900 Series shown**

1. Remove screws and rear right anti scalp wheel assembly (A) from mower deck.
2. Position blower support bracket (B) in place flush against deck.
3. install anti scalp wheel onto bracket and secure in place with new provided M8x30 screws (C).

## Install Pulley and Spacer

1. Remove belt shield on discharge chute side of mower deck.

# PREPARING VEHICLE

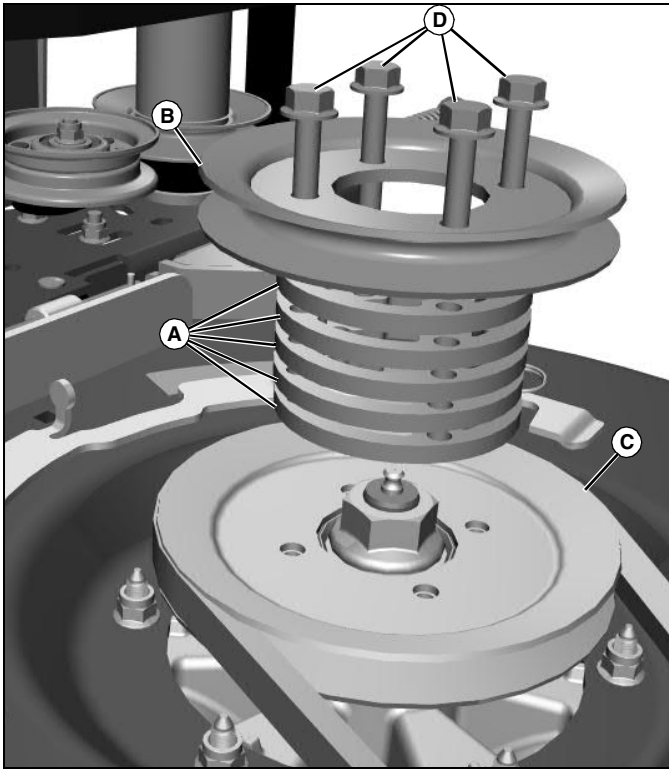

MX25080

2. Install five spacers (A) and extra pulley (B) on sheave (C) using four M8x50 flange head bolts (D), and tighten to 24 N•m (18 lb-ft).

## Install New Gate (Mulch on Demand Mower Decks Only)

1. Park machine safely. (See Parking Safely in the SAFETY section.)



**CAUTION: Avoid injury! Rotating blades are dangerous. Before adjusting or servicing mower:**

- Disconnect spark plug wire(s) or battery negative (-) cable to prevent engine from starting accidentally.
- Always wear gloves when handling mower blades or working near blades.

2. Lift discharge chute up.

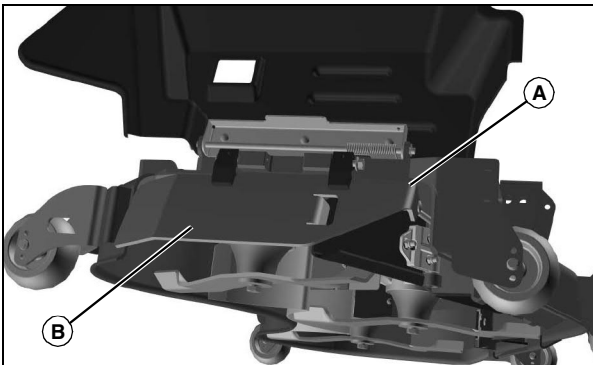

MX25143

3. Remove link assembly (A).

4. Remove discharge gate (B).

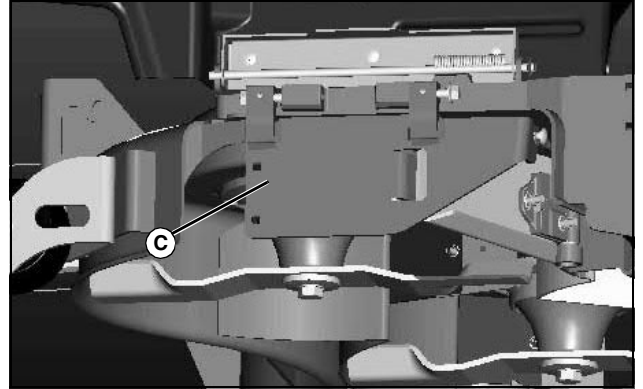

MX26043

5. Install new gate (C) and attach link assembly.

## Gate Extension for MCS Gate

**NOTE: Gate extension must be installed if machine is operated without MCS blower.**

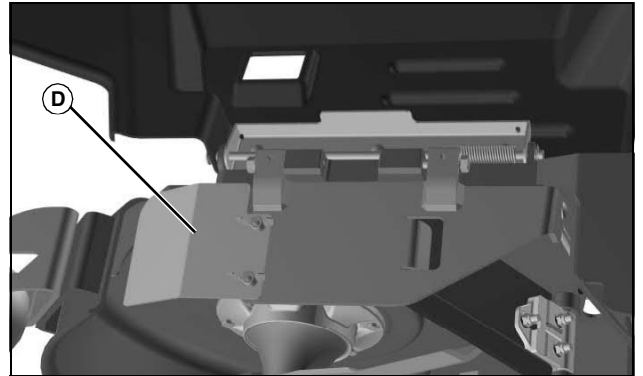

MX25143

1. Install gate extension (D) with hardware and secure in place.

## Install Mulch-On-Demand Position Lever (Mulch on Demand Mower Decks Only)

1. Park machine safely. (See Parking Safely in the SAFETY section.)

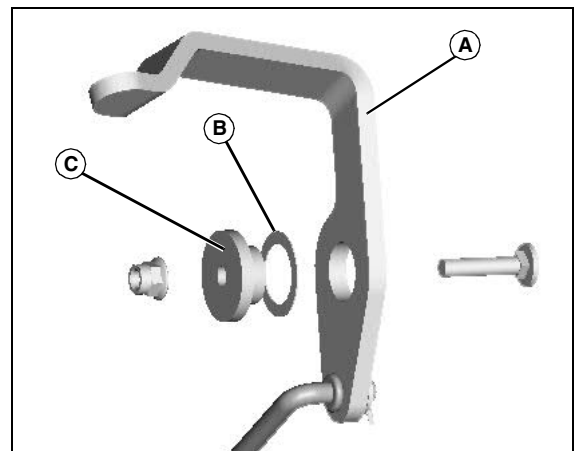

MX26039

2. Place shim washer (B) onto Insert bushing (C).

# PREPARING VEHICLE

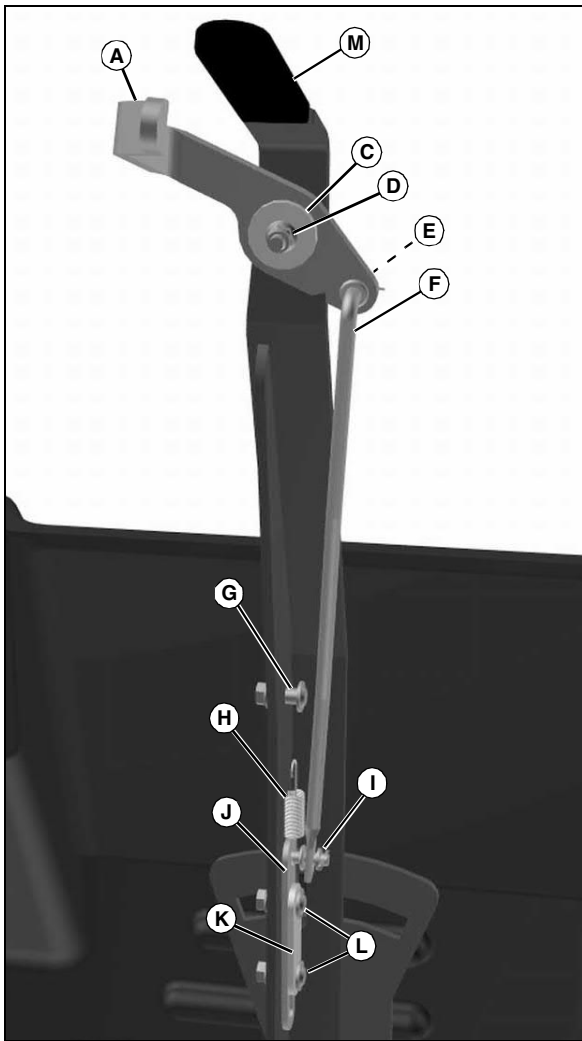

MX25145

3. Insert bushing (C) into lever release (A) and attach to deck mode lever (M) with M6x30 cap screw and nut (D). Tighten hardware.
4. Position pawl plate (J) and shim latch (K) in place and secure with two M6x21 socket head shoulder bolts and nuts (L). Do not overtighten hardware.
5. Install M6x21 socket head shoulder bolt and nut (G). Tighten hardware.
6. Install tension spring (H) from pawl plate (J) to socket head shoulder bolt (G).
7. Install link latch (F) to lever release and pawl plate. Secure link latch with M8.4x1.6 washer and cotter pin (E) and M6.4x1.6 washer and cotter pin (I). Spread cotter pins to secure in place.

## Trim Discharge Chute

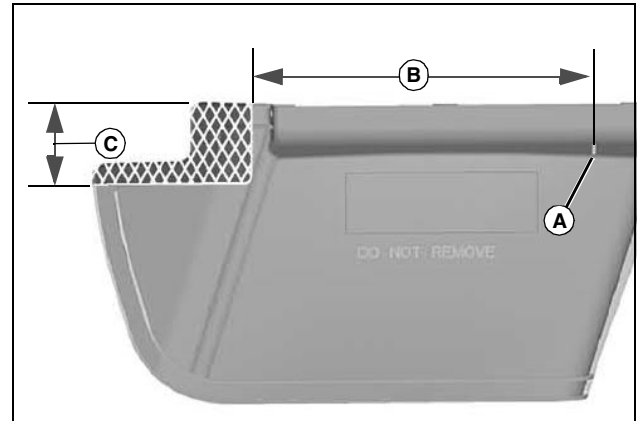

MX22932

1. Begin at point (A) and measure distance (B) as shown. Scribe a mark.
2. Measure distance (C) beginning from hinge side of guard as shown. Scribe a mark.
3. Extend lines from both marks so they meet at a 90° angle and identify the shaded area as shown.
4. Remove shaded area using a suitable cutting tool.

### Specifications

- Distance (B) ..... 423.00 ± 0.80 mm (16.65 ± 0.03 in.)  
 Distance (C) ..... 88.66 ± 0.80 mm (3.50 ± 0.03 in.)

### Specifications (For Mulch on Demand Decks)

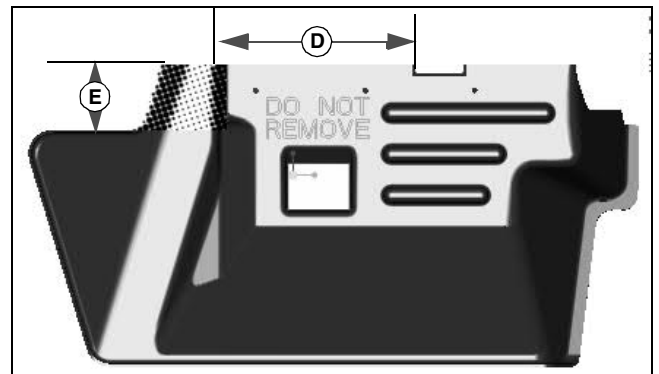

MX26038

- Distance (D) ..... 270.00 ± 0.80 mm (10.62 ± 0.03 in.)  
 Distance (E) ..... 85.00 ± 0.80 mm (3.34 ± 0.03 in.)

## Installing Weight Bracket

### Parts in Kit (Weight Bracket)

Qty.	Description
1	Bracket, Weight
2	Carriage Bolt, M12x35
2	Carriage Bolt, M12x50
4	Locknut, Flange

1. Park machine safely.

# ASSEMBLY

**NOTE: Secure and support vehicle as required. Take all safety precautions.**

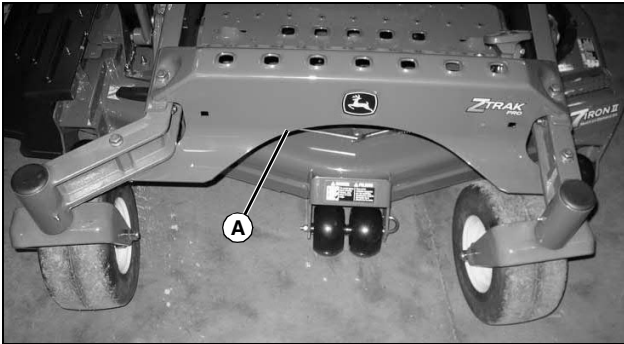

MX25036

2. Clean front cross member (A) area of any debris.
3. Center weight bracket on cross member.

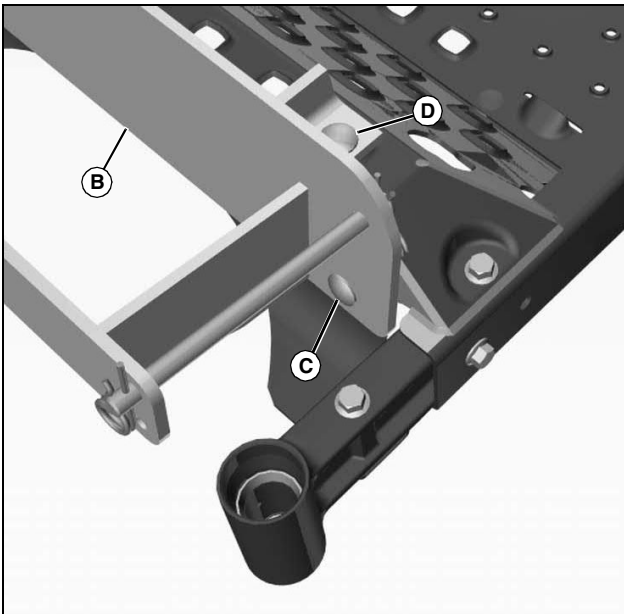

MX25037

- Picture Note: Front caster wheel not shown for photo clarity only.**
4. Align front mounting holes of the weight bracket (B) with the holes in the cross member.
  5. Install M12x35 carriage bolts (C) and nuts. Tighten all hardware.
  6. Install M12x50 carriage bolts (D) through top of weight bracket.

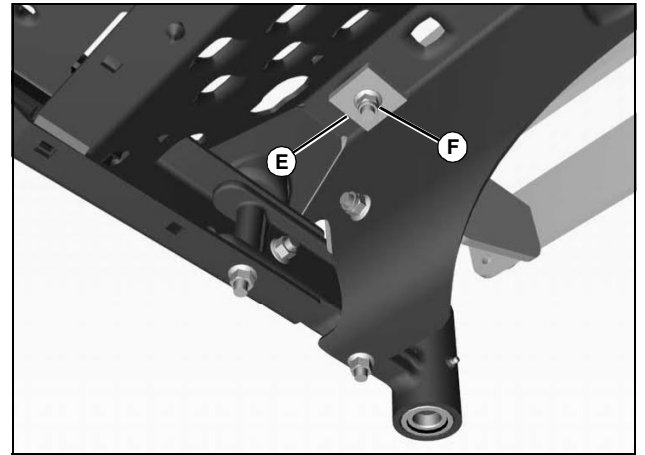

MX25038

7. Install backing plates (E) and nuts (F). Tighten all hardware.

## Assembly

### Dump From Seat Hopper Parts List

Qty.	Description
1	Assembly, Hopper
2	Link, Door
2	Link, Latch
1	Assembly, Handle
2	Carriage Bolt, M8X30
3	Carriage Bolt, M8X25
5	Nut, M8
2	Washer, M8
1	Plate, Seal
1	Seal
8	Hex Head Bolt, M6X20
8	Locknut, M6
9	Pin, Cotter
8	Washer, M10
2	Hex Head Bolt, M12X110

### Blower Assembly Parts List

Qty.	Description
1	Assembly, Blower
1	Assembly, Spring Tension
1	Belt, Primary
1	Bolt, Socket Head, M6x20 (48/54/60/72)

# ASSEMBLY

Qty.	Description
1	Boot, Blower
1	Guard, Primary Belt
5	Bolt, Square Neck, M6x20 (48/54/60 MOD)
6	Bolt, Square Neck, M6x20 (60/72)
5	Locknut, M6 (60 MOD)
6	Locknut, M6 (48/54)
7	Locknut, M6 (60/72)

## Assemble Blower



MX22738



MX22735

1. Remove belt guard (A) and secondary drive belt (B).

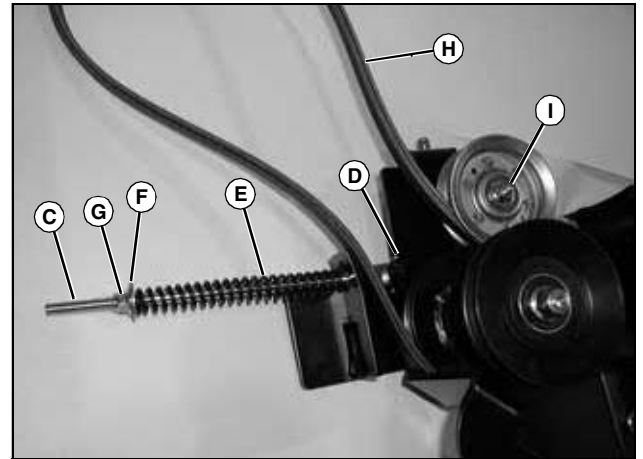

MX22776

2. Install primary tension rod (C), retaining clip (D), spring (E), washer (F), and locknut (G).
3. Install primary drive belt (H).
4. Tighten hardware on idler pulley (I).
5. Install secondary drive belt (B) and tighten idler pulley.
6. Adjust secondary drive belt.
7. Install belt guard (A).

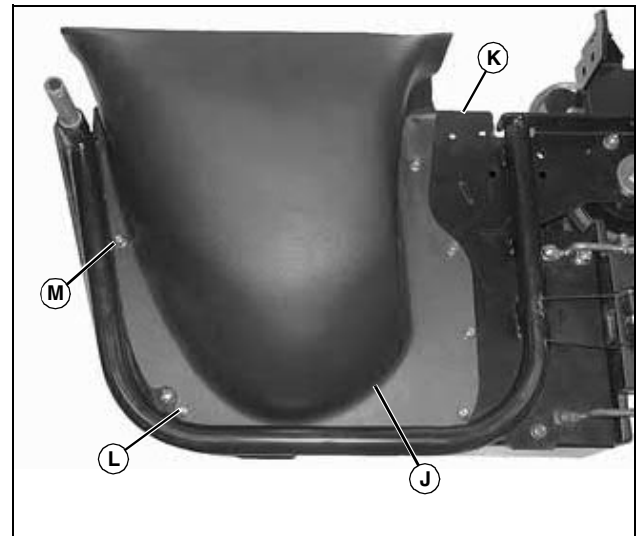

MX22739

**Picture Note: Deck boot for 48/54 in. shown. Socket head cap screw (M) must be installed in this location.**

8. Install blower boot (J) on the bottom of blower housing (K) using the appropriate quantity of M6x20 square neck bolts (L) and one M6x20 socket head bolt (M) with M6 locknuts.



**Suggest:**

**If the above button click is invalid.**

**Please download this document**

**first, and then click the above link**

**to download the complete manual.**

**Thank you so much for reading**

# ASSEMBLY

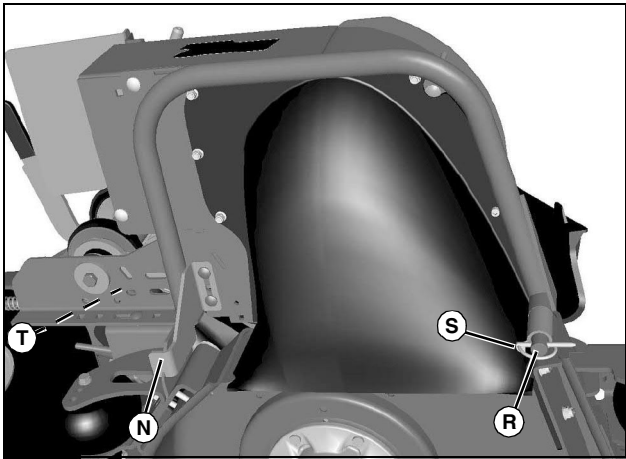

MX47237

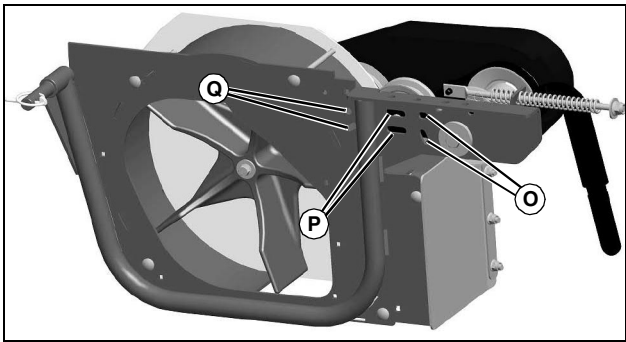

MX43144

9. Install rear mounting bracket (N) using two M8x25 carriage bolt and locknuts:

- For 72 in. decks, place bracket into slots (O).
- For 60 in. and all Mulch on Demand decks, place bracket into slots (P).
- For 48 and 54 in. decks place bracket into slots (Q).

10. Install blower front pivot pin (R) and secure with lynch pin (S) in front mounting bracket. Swing blower into position, and align rear mounting bracket to install release handle (T) and M8x25 carriage bolt.

11. Tighten hardware on rear mounting bracket.

12. Connect primary drive belt from blower to drive sheave on deck.

13. Install primary belt guard onto deck.

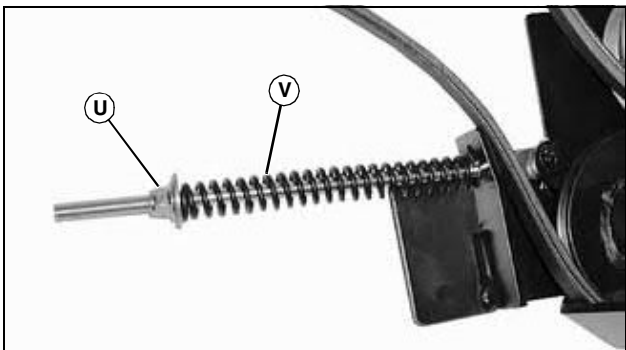

MX22741

14. Adjust primary drive belt.

15. Tighten nut (U) on tension rod until spring (V) length is 150 +/- 10 mm (6.0 +/- 0.4 in.).

## Assembling Frame

1. Park machine safely. (See Parking Safely in the SAFETY section.)

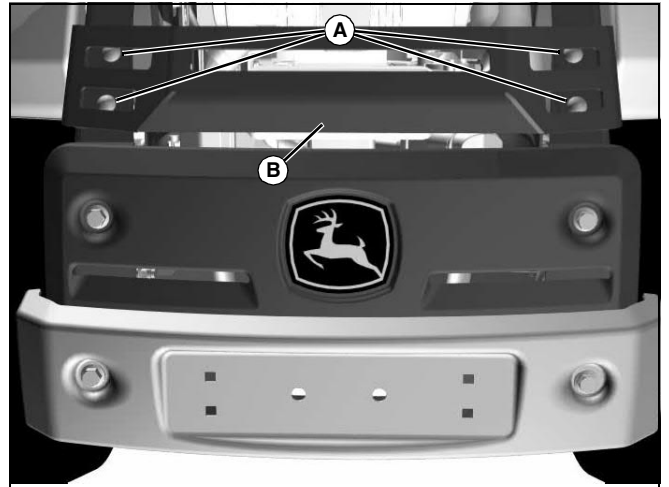

MX25070

2. If model is equipped with an engine guard, remove four carriage bolts, washers, and locknuts (A), and remove engine guard (B).



**CAUTION: Avoid injury! Bumper weighs approximately 90 lbs. John Deere recommends that two people be used when removing bumper from machine.**

**NOTE: If installed, remove rear side weights from mower. They are not compatible with an MCS.**

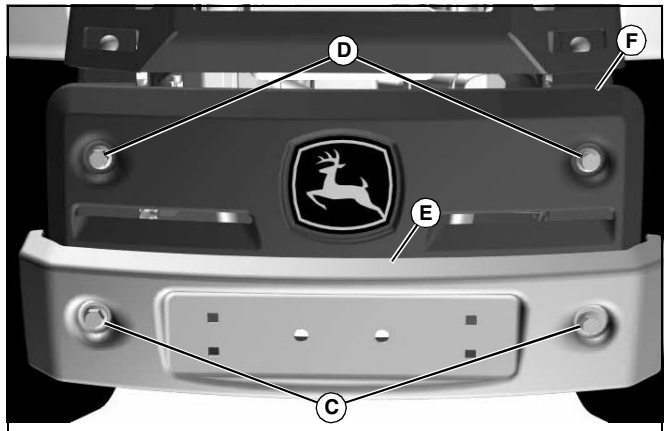

MX25070

3. Remove two M12 nuts (C) and two M12x30 flange head bolts (D). Remove bumper (E) and rear grille (F).

**<https://www.ebooklibonline.com>**

Hello dear friend!

Thank you very much for reading.

Enter the link into your browser.

The full manual is available for immediate download.

**<https://www.ebooklibonline.com>**