

8850 TRACTOR



OPERATORS MANUAL 8850 TRACTOR

OMRW16848 J4 English

**JOHN DEERE TRACTOR WORKS
OMRW16848 J4**

LITHO IN THE U.S.A.
ENGLISH



WARRANTY

The warranty on this tractor appears on your copy of the purchase order which you should have received from your dealer when making your purchase. This warranty provides you the assurance that John Deere will back its products where defects appear within the warranty period. In some circumstances, John Deere also provides field improvements, often without charge to the customer, even if the product is out of warranty.

Warranty and field improvements are a part of John Deere's product support program for customers who operate and maintain their equipment as described in this manual. Should the equipment be abused, or modified to change its performance beyond the original factory specifications, the warranty will become void and field improvements may be denied. Setting fuel delivery above specifications or otherwise overpowering machines will result in such action.

The tire manufacturer's warranty packed with your machine may not apply outside the U.S.



This safety alert symbol indicates important safety messages in this manual. When you see this symbol, be alert to the possibility of personal injury and carefully read the message that follows.



Worldwide symbols are used to assist identification and operation. In this manual, an identifying symbol is placed by the instructions, like the example at left for the symbol on the engine oil pressure gauge. The cylinder block in the symbol represents the engine, the drop signifies oil, and the arrows indicate pressure. Regardless of the language used in a nation, this symbol means engine oil pressure without translation.

This operator's manual contains SI Metric equivalents which follow immediately after the U.S. customary units of measure.

"Right-hand" and "left-hand" sides of the tractor are determined by facing in the direction of tractor forward travel.

Record your tractor serial numbers in the space provided in the Specifications section. Provide this information to your dealer when ordering parts.



John Deere 8850 Tractor

RW8070

Contents

Safety	2
Controls and Instruments	10
Lighting and Signals	16
Operator's Station	20
Engine Break-in	28
Prestarting Checks	30
Operating the Engine	33
Operating the Tractor	42
Rockshaft and 3-Point Hitch	46
Remote Hydraulic Cylinders	57
Drawbar and PTO	63
Ballast	69
Wheels, Tires, and Treads	74
Transporting	82
Fuels and Lubricants	86
Lubrication and Maintenance	91
Troubleshooting	112
Service	122
Storage	149
Crime Prevention Tips	151A
Specifications	152
Identification Numbers	154
Daily Maintenance	156
Lubrication and Maintenance Record	157
Index	165

<https://www.ebooklibonline.com>

Hello dear friend!

Thank you very much for reading.

Enter the link into your browser.

The full manual is available for immediate download.

<https://www.ebooklibonline.com>

Safety

OPERATE TRACTOR SAFELY

Never allow riders on the tractor.

Slow down for hillsides, rough ground, and sharp turns.

Always place transmission in PARK before dismounting. Leaving transmission in gear with engine stopped will NOT prevent the tractor from moving.

Keep all shields in place.

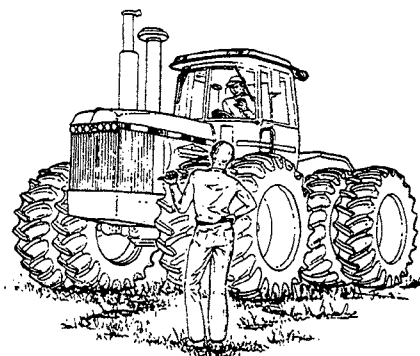

AJ7;RW4418 U01;SA01 X2 011081

AVOID TIP-OVERS

Use a seat belt under almost all operating conditions.

Avoid holes, ditches, and obstructions which may cause the tractor to tip, especially on hillsides.

Never drive near the edge of a gully or steep embankment—it might cave in.

Be especially careful if outer duals are removed for any reason. Danger of an overturn increases greatly with narrow tread 79 in. (2.0 m) or less and high speed.

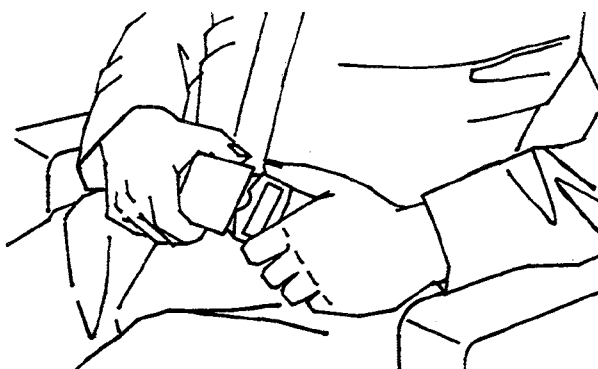

AJ7;RW4419 U01;SA02 X3 270982

EMERGENCY EXIT

For an emergency exit, SOUND-GARD® body windows can be opened. Remove the quick-lock pins (A) and headed pins (B) from window latches, and push window wide open.

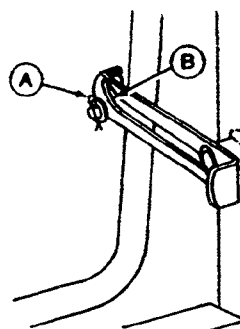

AJ7;RW4420 U01;SA03 X2 150982

MAKE TRACTOR VISIBLE ON HIGHWAY

Turn light switch to "H" position. Never use white lights which are visible from the rear. Always dim head lamps before meeting another vehicle. Keep head lamps properly adjusted.

Add SMV emblem, reflectors, and auxiliary lighting to equipment as required for safety and by local regulations.

Before operating tractor on highway, be sure flashing warning lamps work properly. Adjust rear view mirror, and clean windows and SMV emblem.

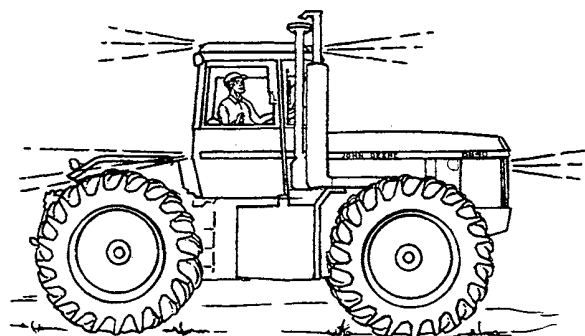

AJ7;RW4423 U01;SA06 X2 270284

TRANSPORT TRACTOR SAFELY

Before descending a steep hill (A), shift to a low gear (B) to control the tractor with little or no braking. Never coast downhill.

When transporting on icy or graveled surfaces, be alert for skids which could result in loss of steering control. To decrease chance of skids, reduce speed and be sure tractor is properly ballasted.

Before towing tractor, see instruction in Transporting section. Never tow tractor faster than 5 mph (8 km/h) with all wheels on the ground. With rear wheels raised, never tow tractor faster than 10 mph (16 km/h).

Use of radial ply tires requires special precautions. (See Radial Ply Tires in Wheels, Tires and Treads section.)

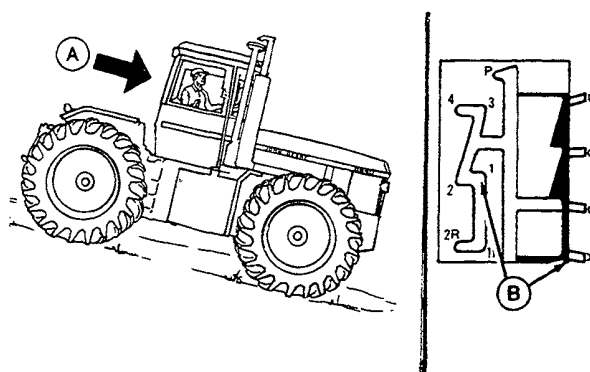

AJ7;RW4421 U01;SA04 X2 270284

TOW EQUIPMENT PROPERLY

Use caution when towing loads at transport speeds. Reduce speed if towed load weighs more than the tractor and is not equipped with brakes. Avoid hard braking applications. (Consult implement operator's manual for recommended transport speeds.)

Use additional caution when transporting towed loads under adverse surface conditions, when turning, or on inclines.

U01;SAX1 06 140884

1U2;P3 111084

USE A SAFETY CHAIN

A safety chain will help control drawn equipment (B) should it accidentally separate from the drawbar (A) while transporting. Using the appropriate adapter parts, attach the chain to the tractor drawbar support or other specified anchor location. Provide only enough slack in the chain to permit turning. See your John Deere dealer for a chain with a strength rating greater than the gross weight of the towed machine.

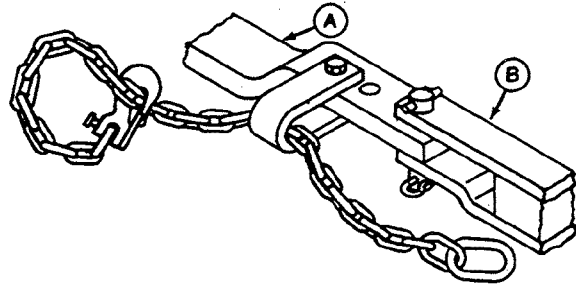

AB6;TS163 053;SA A 120284

STAY CLEAR OF PTO

Stop the engine and be sure the PTO drive line has stopped before:

- Connecting or disconnecting implement drive line
- Making adjustments on the implement
- Cleaning out PTO driven equipment

PTO master shield (A) and drive line shields should be in place at all times except for special applications as directed in the implement operator's manual.

The PTO shaft guard should be in place when the PTO is not being used.

Install lock bars in tractor hinge before operating stationary PTO equipment. Be sure lock bars are removed before driving tractor.

Operate PTO at recommended speed.

Avoid loose-fitting or dangling clothing.

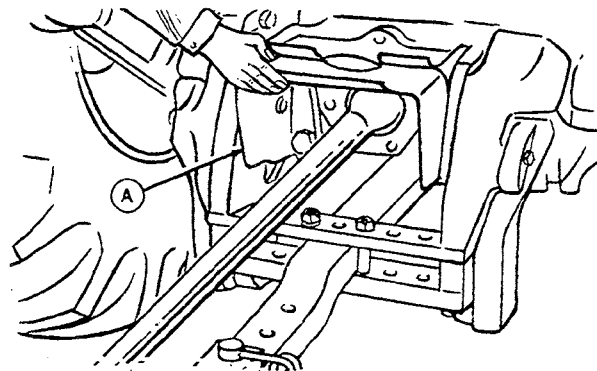

AJ7;RW4424 U01;SA08 X2 270284

OPERATE ON HILLSIDE SAFELY

Always operate tractor with dual wheels (A) except for width limitations when transporting. Avoid sharp uphill turns.

Keep transmission-hydraulic oil level at upper mark on dipstick (B) when operating on hillsides. Low oil level might result in loss of steering and clutch engagement. If this should happen, hold tractor with brakes, shift to PARK, stop engine, and add hydraulic oil to proper level.

Before operating on extremely steep slopes, overfill transmission-hydraulic system by 3.2 to 5.3 gal. (12 to 20 L). This is particularly important when using large hydraulic cylinders, due to the volume of oil used to extend them.

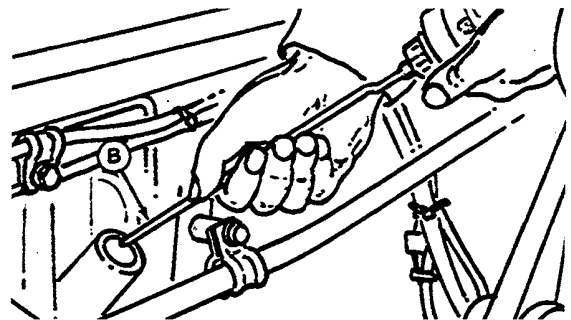
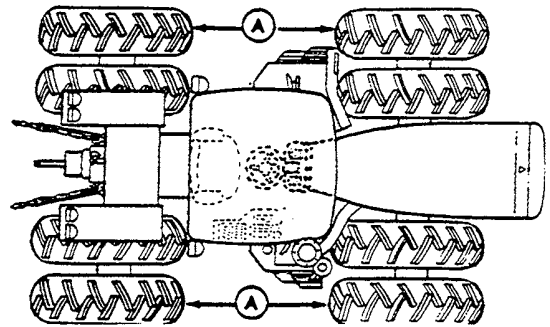

AJ7;RW8077,RW8071 U01;SA07 X2 270982

STAY CLEAR OF MOVING TRACTOR

Be sure everyone is clear of tractor and attached equipment before starting engine or moving steering wheel. Tractor and equipment move (A), even with transmission in PARK. Some steering movement often occurs as engine starts.

Never try to get on or off a moving tractor.

Before dismounting, place the transmission in PARK and lower implements to the ground. If tractor is to be left unattended, stop the engine and remove the key.

Never attempt to start or operate tractor except from operator's station.

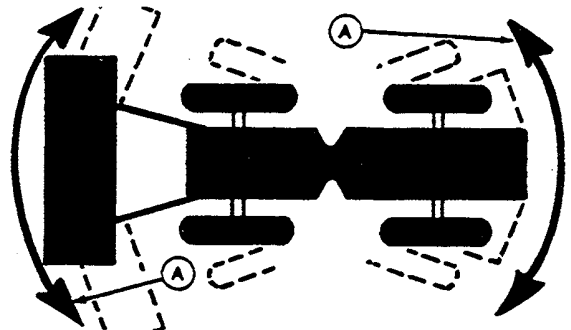

AJ7;RW8078 U01;SA10 X2 270982

DO NOT MODIFY TRACTOR

Unauthorized modification to the machine may impair the function and/or safety and affect machine life.

Never modify structural members of SOUND-GARD body (A) by welding, bending, drilling or cutting as this might weaken the structure. If any structural member is damaged, replace the entire structure. Do not attempt repairs.

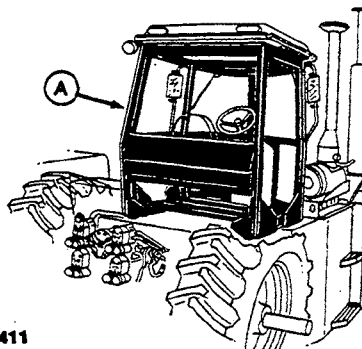

RW10411

AJ7;RW1041 1 U01;SA09 X2 060484

AVOID TRACTOR RUNAWAY

Avoid possible injury or death from a machine runaway.

Do not start engine by shorting across starter terminals. Machine will start in gear and move if normal starting circuitry is bypassed.

Start engine only from operator's seat with transmission in neutral or park. NEVER start engine while standing on ground.

U01;SA17 X2 150982

SERVICE TRACTOR SAFELY

Do not service the tractor while it is in motion or while the engine is running.

Stay clear of hinge area when engine is running. Stop engine and remove key before working near hinge.

Drive shaft does not turn at engine start-up until clutch pedal is depressed and released. Be aware of sudden rotation of drive shaft as clutch is actuated.

Install lock bars (A) on tractor hinge before performing service work in hinge area. Be sure lock bars are removed before operating tractor.

The air conditioning system is pressurized. Improper servicing may cause refrigerant to penetrate eyes and skin or cause burns. Special equipment and procedures are required to service air conditioning system. (See your John Deere dealer.)

Reinstall all shields removed during service.

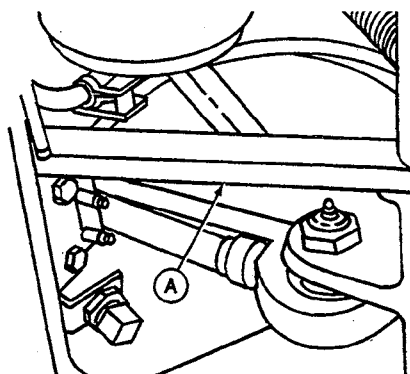

AJ7;RW4425 U01;SA11 X2 171282

1U2;P6 111084

AVOID HIGH-PRESSURE FLUIDS

Escaping fluid under pressure can penetrate the skin causing serious injury. Relieve pressure before disconnecting hydraulic or other lines. Tighten all connections before applying pressure. Keep hands and body away from pin holes and nozzles which eject fluids under high pressure. Use a piece of cardboard or paper to search for leaks. Do not use your hand.

If any fluid is injected into the skin, it must be surgically removed within a few hours by a doctor familiar with this type injury or gangrene may result.

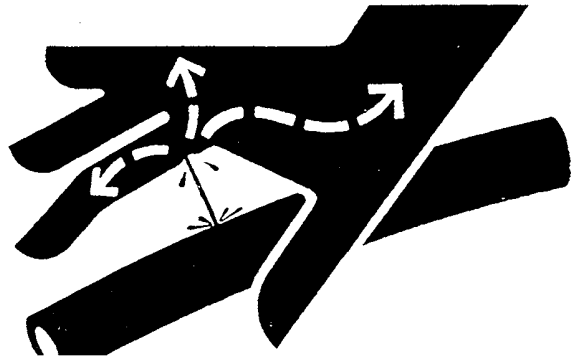

AJ7;X9811 U01;SA18 X2 150982

AVOID EXPLOSIONS OR FIRE

Accumulation of trash in engine and exhaust area can create a fire hazard, particularly when operating in trash field conditions. Keep this area free of debris. (See Service as Required in the Lubrication and Maintenance section.)

Batteries produce explosive gas. Before using booster batteries, read the instructions listed under Using a Booster Battery, in Operating the Engine section.

To avoid sparks, turn the charger off before connecting or disconnecting a battery charger.

Be careful with starting fluid or any type of fuel. Do not refuel the tractor when the engine is hot or running. Never smoke while handling fuel.

A fire extinguisher can be mounted to your tractor. It is available from your John Deere dealer. Be sure to see the owners manual packaged with the extinguisher for operation and service instructions.



AJ7;RW5895,RW2369 U01;SA13 X2 060183

USE ELECTRIC COOLANT HEATER PROPERLY

Use a heavy-duty grounded cord to connect coolant heater (A) to electrical power.

Do NOT plug into electrical power unless heating element is immersed in coolant. Sheath could burst and result in personal injury.

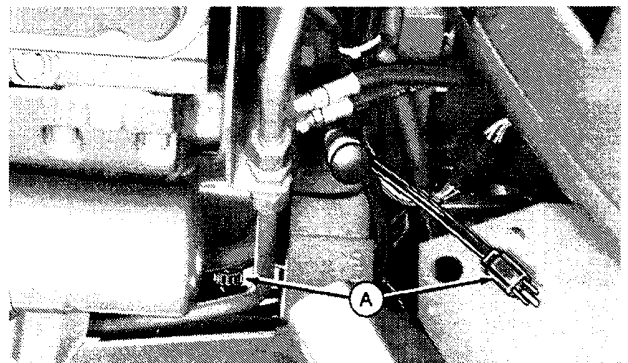

AJ7;RW4288 U01;SA23 X2 190384

SERVICE BRAKE ACCUMULATOR SAFELY

Before disconnecting brake accumulator or brake valve, relieve all pressure from accumulator. To do so open bleed screws and pump brake pedal with engine stopped, until pedal easily goes all way down.

The accumulator is charged with dry nitrogen to a pressure of 500 psi (3450 kPa) (35 bar). If it needs recharging, have job done only by a qualified service person and only with dry nitrogen.

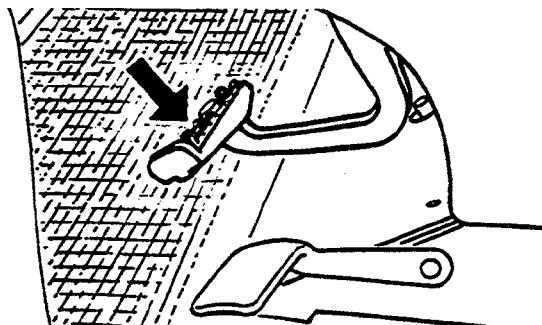

AJ7;RW8103 U01;SA22 X2 161282

OBSERVE ELECTRICAL SERVICE PRECAUTIONS

Keep all sparks and flames away from batteries, as gas given off by electrolyte is explosive. To avoid sparks, connect ground cable (A) last and disconnect it first. When using a booster battery, follow instructions in Operating the Engine section.

Disconnect battery ground cable before working in an area where you might accidentally contact electrical components causing shocks, burns, or damage to electrical system.

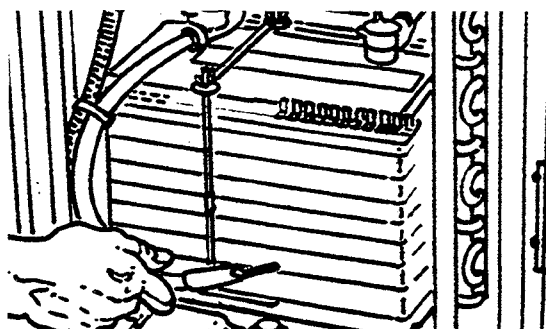

AJ7;RW8074 U01;SA19 X2 171282

SERVICE COOLING SYSTEM SAFELY

Do not remove radiator cap (A) when engine is hot. Shut the engine off and wait until it cools. When removing cap, turn to the first stop to relieve pressure before removing it completely.

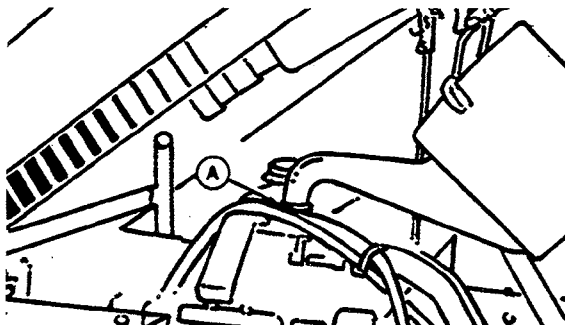

AJ7;RW8076 U01;SA21 X2 270982

AVOID EXHAUST FUMES

Never run engine in a closed building.

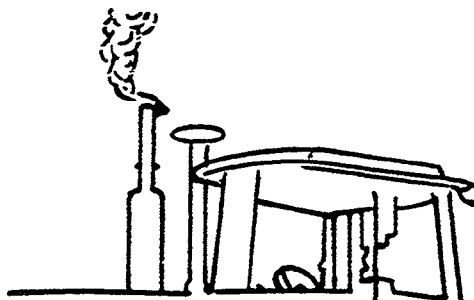

AJ7;RW8075 U01;SA20 X2 270982

SERVICE TIRES SAFELY

Failure to follow proper procedures when mounting a tire on a wheel or rim can produce an explosion which may result in serious injury or death. Do not attempt to mount a tire unless you have the proper equipment and experience to perform the job. Have it done by your John Deere dealer or a qualified tire repair service.

When sealing tire beads on rims, never exceed 35 psi (241 kPa) (2.4 bar) or maximum inflation pressures specified by tire manufacturers for mounting tires. Inflation beyond this maximum pressure may break the bead, or even the rim, with dangerous explosive force. If both beads are not seated when the maximum recommended pressure is reached, deflate, reposition tire, relubricate bead and reinflate.

Detailed tire mounting instructions, including necessary safety precautions, are contained in John Deere Fundamentals of Service (FOS) Manual 55, Tires and Tracks, available through your John Deere dealer. Such information is also available from the Rubber Manufacturers Association and from tire manufacturers.

- A—Use a Safety Cage if Available.
- B—Do Not Stand Over Tire. Use a Clip-on Chuck and Extension Hose.

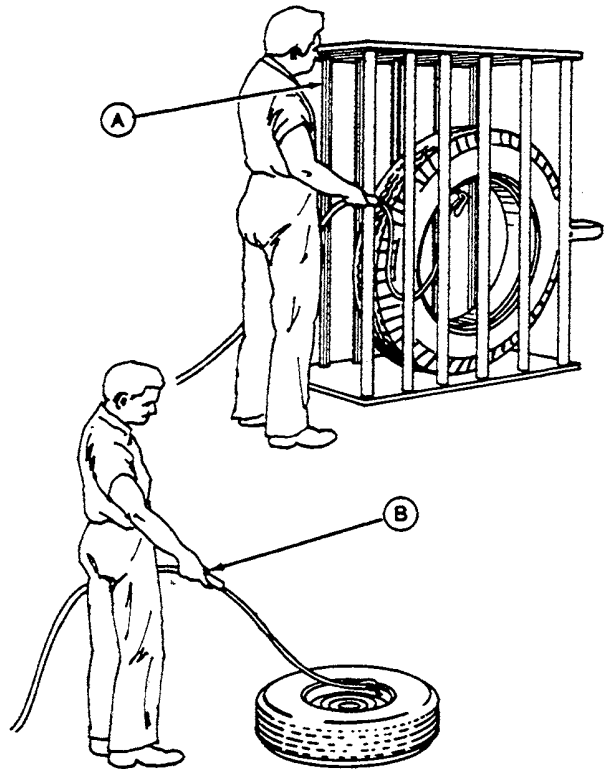

AB6;TS0123 053;TSAFT A 091283

HANDLE CHEMICALS PROPERLY

SOUND-GARD body air filters (A) are not designed to filter out harmful chemicals. Follow instructions given in the implement operator's manual and those given by the chemical manufacturer when using agricultural chemicals.

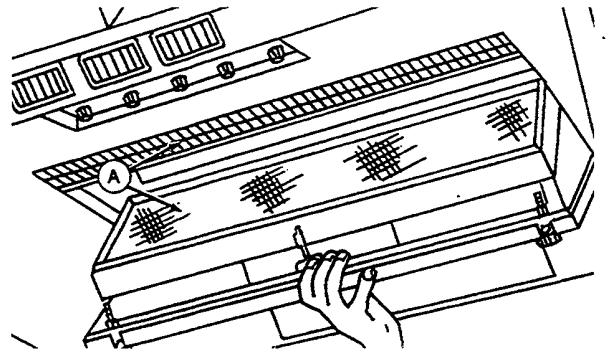

AJ7;RW5704L U01;SAX1 18 151282

PROTECT AGAINST NOISE

Prolonged exposure to loud noise can cause impairment or loss of hearing.

Wear a suitable hearing protective device such as earmuffs (A) or earplugs (B) to protect against objectionable or uncomfortable loud noises.

- A—Earmuffs
- B—Earplugs



AJ7;RW213 001;SA14 X2 290284

1U2;P9 190384

Controls and Instruments

SOUND-GARD® BODY CONTROLS

- | | |
|--|---------------------------------------|
| A—Left Wiper Switch | I—Radio Tuning Knob |
| B—Air Conditioning Temperature Control | J—Radio Tuning Push Buttons |
| C—Blower Switch | K—AM/FM Selection Bar |
| D—Heater Temperature Control | L—Radio On-Off/Volume/Balance Control |
| E—Right Wiper Switch | M—Radio Tone Control |
| F—Console Lamp | N—Air Louver |
| G—Dome Lamp Switch | |
| H—Dome Lamp | |

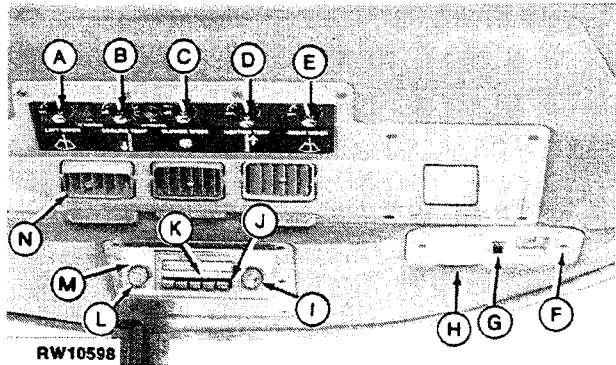

AJ8;RW10598 U01;C1X1 01 041084

TRACTOR CONTROLS

- | | |
|------------------------------------|---------------------------------|
| A—PTO Lever | L—Rockshaft Depth Stop Knob |
| B—Steering Wheel Telescope Release | M—Rockshaft Control Lever |
| C—Turn Signal Control | N—Rockshaft Load Selector Lever |
| D—Steering Wheel | O—Throttle Pedal |
| E—Lighter | P—Brake Pedal |
| F—Key Switch | Q—Differential Lock |
| G—Engine Stop Knob | R—Steering Wheel Tilt Release |
| H—Horn Button | S—Dimmer Switch |
| I—Hand Throttle | T—Clutch Pedal |
| J—Shift Lever | U—Light Switch |
| K—Remote Cylinder Levers | V—Starting Aid Switch |

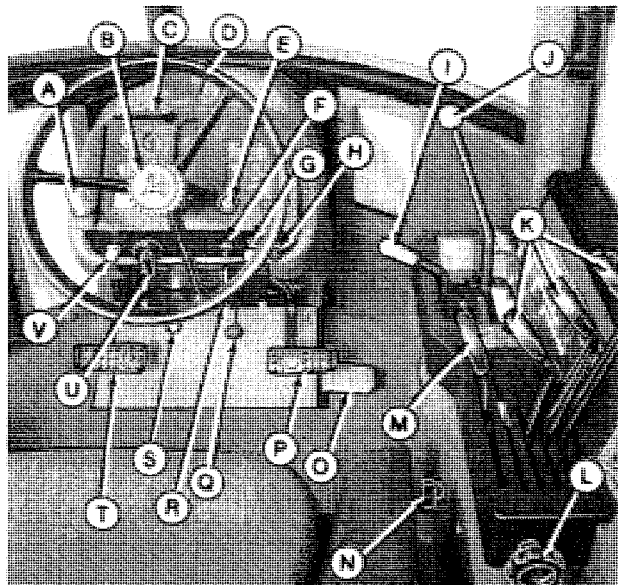

AJ8;RW9093 U01;C102 X2 061082

GAUGES AND INSTRUMENTS

- | |
|--|
| A—Engine Oil Pressure Gauge |
| B—Voltmeter |
| C—Fuel Gauge |
| D—Engine Temperature Gauge |
| E—Tachometer Display |
| F—Head Lamp Hi-Beam Indicator |
| G—Tachometer Touch Pad |
| H—Engine Stop Signal |
| I—Service Alert Signal |
| J—Hourmeter |
| K—INVESTIGATOR II™ Warning Indicator Lamps |

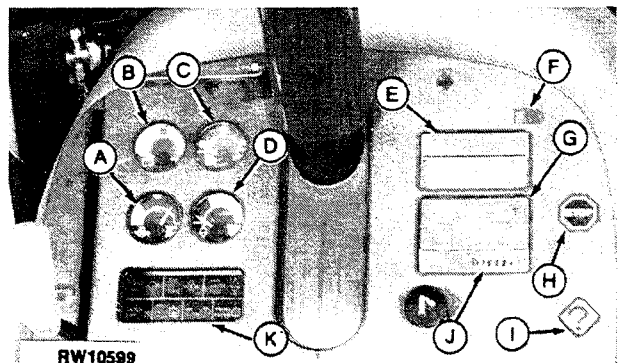

AJ8;RW10599 U01;C103 X2 041084

INVESTIGATOR II WARNING INDICATOR LAMPS

- A—Transmission Oil Pressure Indicator
- B—Engine Oil Pressure Indicator
- C—Engine Water Temperature Indicator
- D—Clutch Temperature Indicator
- E—Hydraulic Oil Temperature Indicator
- F—Air Filter Restriction Indicator
- G—Transmission Filter Restriction Indicator

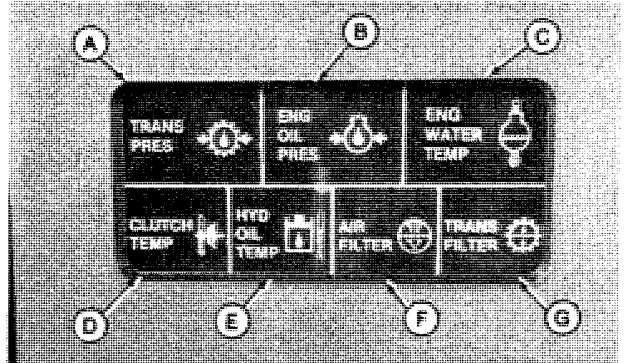

AJ8;RW5709 U01;CI04 X2 041084

CHECK INSTRUMENTS OFTEN

IMPORTANT: See your John Deere dealer if any instrument malfunctions. Operate tractor only if all instruments work properly.

Leave key switch on while operating tractor so instruments will function. Form a habit of checking them often.

Check indicator lamps and audible warning signal each time engine is started. All INVESTIGATOR II warning indicator lamps (A), "Service Alert" (B), and red "Stop Engine" (C) signals should glow for 5 seconds when key switch is turned to first position. Audible warning tone should be heard for the first 2 seconds while lamps glow.

NOTE: If blower speed switch is on, air conditioner "Lo" and "Hi" pressure lights (D) should glow 5 seconds for bulb check. (Also see Adjusting Air Conditioning in Operator's Station section.)

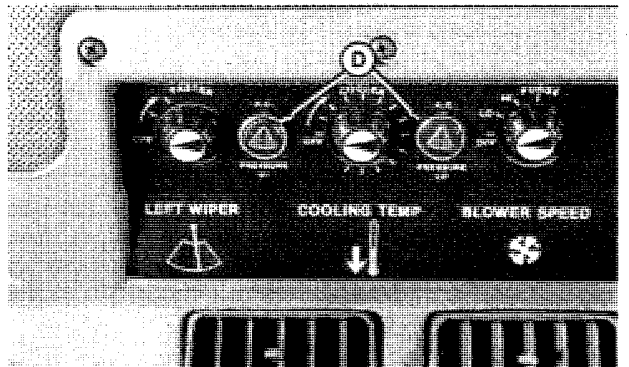
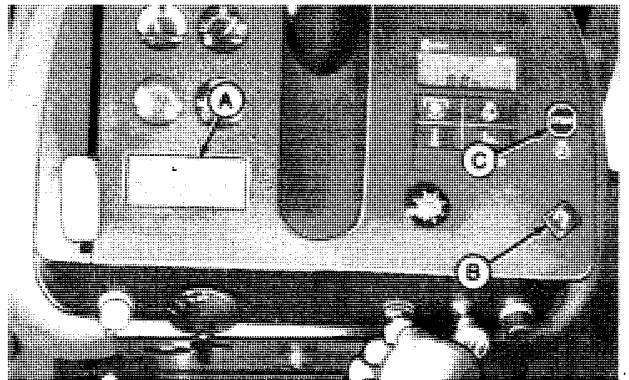

AJ8;RW4076,RW8604 U01;CI05 X2 290284

WATCH FUEL LEVEL

Stop to refuel before fuel gauge (A) reaches empty mark (B).

Use diesel fuel specified in Fuels and Lubricants section.

Should tractor run out of fuel and not start in several tries, air must be bled from fuel system. (See Bleeding Fuel Lines in Service section.)

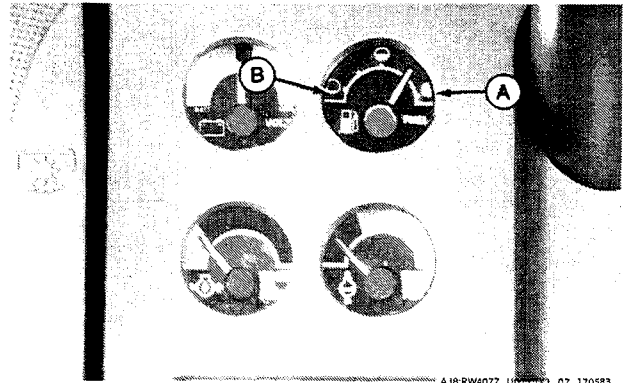

AJB.RW4077 U07.C01 07 170593

OBEY "STOP ENGINE" SIGNAL

IMPORTANT: If the "Stop Engine" signal comes on, shut down the engine immediately and place transmission in park. Then determine and correct the cause.

A red "Stop Engine" signal (A) flashes whenever a vital tractor system malfunctions (such as cooling or lubrication). A steady, audible tone also accompanies this signal.

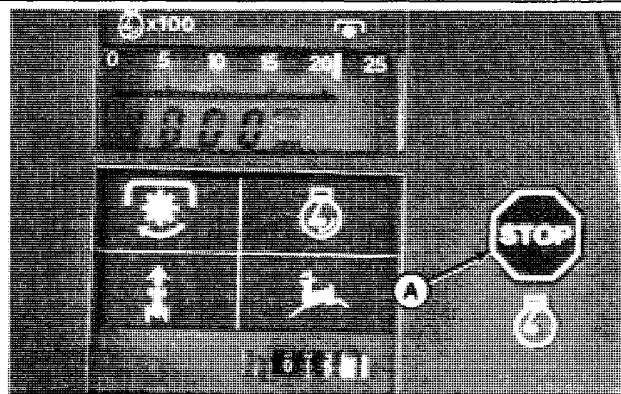

AJB.RW4077 U07.C01 07 170593

OBSERVE "SERVICE ALERT" SIGNAL

An amber "Service Alert" signal (A) glows when a problem develops which does not require immediate engine shut down. Observe gauges and indicator lamps for possible cause. A maintenance check or a change in tractor operation should be initiated as soon as possible. An audible "beep" on critical functions alerts the operator to a function that has reached a warning condition.

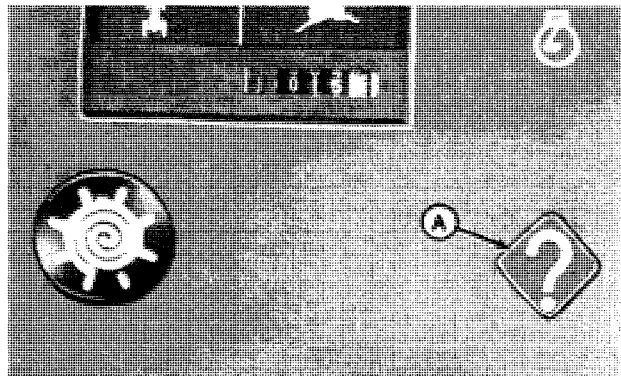

AJB.RW4077 U07.C01 07 170593

CHECK VOLTMETER

With key switch on and engine stopped, voltmeter should reach left-hand green band (A). If it does not, batteries are undercharged.

With engine running, needle should rise to right-hand green band (B) indicating batteries charging, system normal. Turning on lights or other electrical load causes needle to move slightly left within the green band, lower voltage is indicated, but operation is normal.

NOTE: When operating in warm ambient temperatures with batteries fully charged, it is normal for needle to run in black area (E).

If needle moves into either amber band (C), INVESTIGATOR II, "Service Alert" signal (D) will glow. If needle stays in either amber band, see your John Deere dealer.

If needle moves to left-hand amber band, move tractor to service area before shutting off engine; it may not restart.

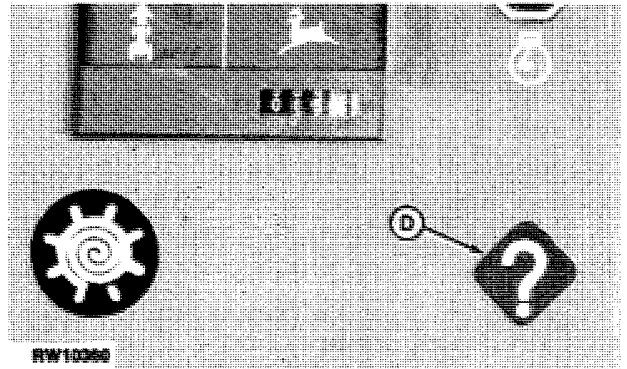
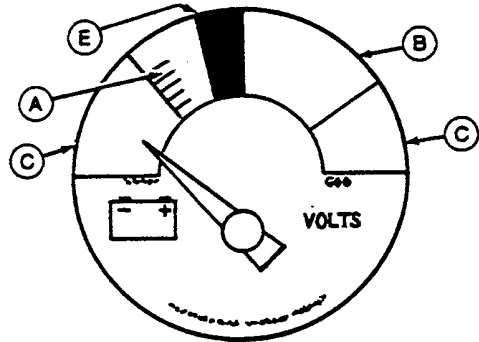

AJ8;RW8605,RW10360 U01;CI20 X2 290284

WATCH ENGINE OIL PRESSURE GAUGE

IMPORTANT: NEVER operate engine without sufficient oil pressure—not even for a minute.

If engine oil pressure falls too low, pressure gauge (A) needle drops into red zone (B), “ENG OIL PRES” indicator (C) will glow, “Stop Engine” signal (D) will flash, and warning horn will sound. Stop engine immediately and determine the cause. If low oil level is not the problem, see your John Deere dealer

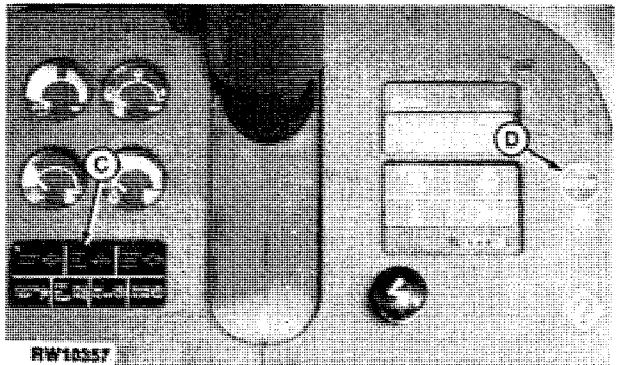
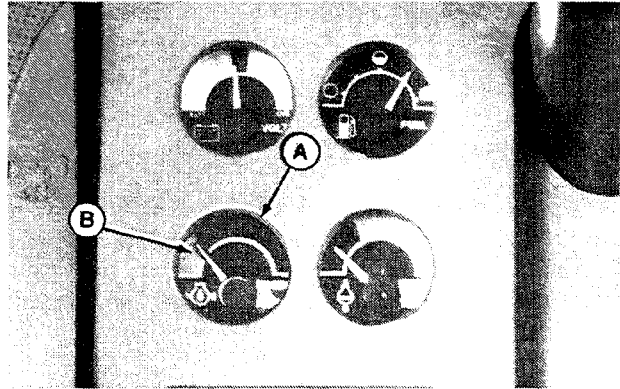

- A—Engine Oil Pressure Gauge
- B—Red Zone
- C—Engine Oil Pressure Indicator Light
- D—Stop Engine Signal

AJ8;RW4081,RW10357 U01;CI21 X2 290284

CHECK ENGINE TEMPERATURE GAUGE

Green and green/white striped area (A) of temperature gauge represents the normal safe operating temperature. If gauge reaches red and white striped area (B), "ENG WATER TEMP" indicator (C) will glow, "Service Alert" signal (D) will come on.

Check grille screens and radiator for plugging. Check coolant level when engine cools down. Reduce load or shift to a lower gear.

If needle reaches solid red area (E), red "Stop Engine" signal (F) will flash and steady tone will sound. Stop engine immediately and determine the cause. (See Troubleshooting section.)

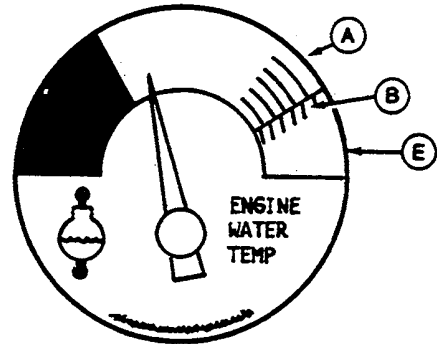

- A—Green and Green/White Striped Area
- B—Red and White Striped Area
- C—Engine Water Temperature Indicator
- D—Service Alert Signal
- E—Solid Red Area
- F—Stop Engine Signal

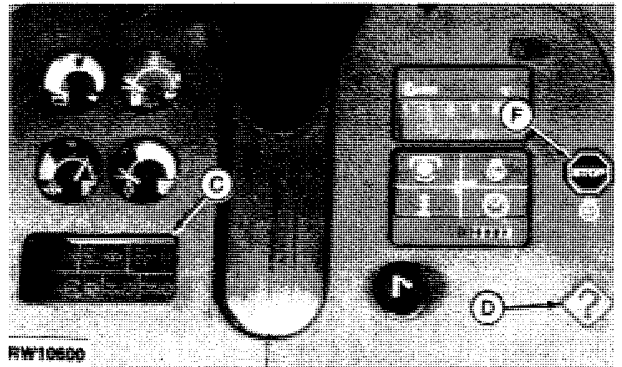

AJ8;RW8609,RW10600 U01;CI01 X3 041084

WATCH TRANSMISSION OIL PRESSURE INDICATOR

If transmission control pressure or lube pressure falls too low, "TRANS PRES" indicator (A) will glow, "Stop Engine" signal (B) will flash and warning horn will sound. Stop tractor and determine cause. If low transmission-hydraulic oil level is not the problem, see your John Deere dealer.

NOTE: If transmission hydraulic oil is cold (below 14°F (−10°C) "TRANS PRES" indicator and service alert signal (C) may glow. Warm transmission hydraulic oil before placing tractor under load. (See Transmission-Hydraulic System Warm-up in Operating the Engine section.)

When shifting, clutching or operating PTO, "TRAN PRES" light may flicker. This is normal.

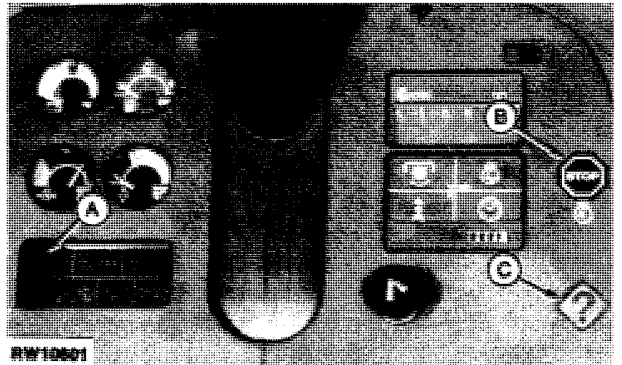

AJ8;RW10601 U01;CI12 X2 041084



Suggest:

If the above button click is invalid.

Please download this document

first, and then click the above link

to download the complete manual.

Thank you so much for reading

WATCH CLUTCH TEMPERATURE INDICATOR

If clutch cooling oil temperature becomes excessive, "CLUTCH TEMP" (A) and "Service Alert" (B) signals will glow and warning horn beeps. Allow several minutes to cool clutch. Place transmission in park or neutral. With clutch pedal disengaged, run engine at 1000 to 1500 rpm. If warning persists, see your John Deere dealer.

IMPORTANT: High clutch oil temperatures are usually caused by excessive clutch slippage or pedal riding.

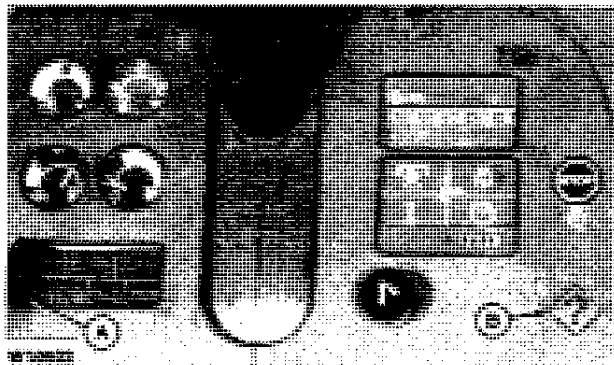

AJ8;RW10602 U01;CI15 X2 041084

WATCH HYDRAULIC OIL TEMPERATURE INDICATOR

If hydraulic oil becomes excessively hot, "HYD OIL TEMP" indicator (A) and "Service Alert" (B) signal will glow and warning horn will beep. Reduce transmission or hydraulic load. Check for low transmission-hydraulic oil level and plugged oil cooler. If the oil temperature continues to rise, red "Stop Engine" (C) signal will flash and horn tone becomes constant. Shut engine down and determine cause. If problem is not found, see your John Deere dealer.

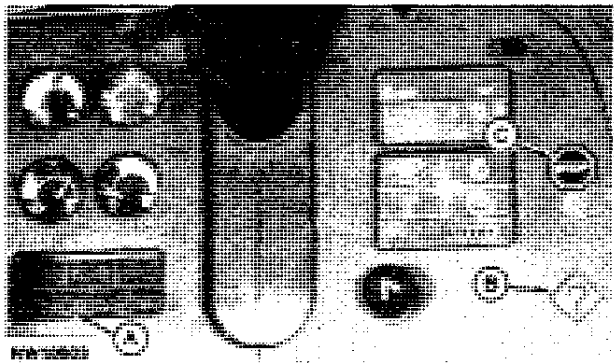

AJ8;RW10603 U01;CI16 X2 041084

WATCH AIR FILTER RESTRICTION INDICATOR

"AIR FILTER" indicator (A) and "Service Alert" signal (B) glow to indicate a restriction to intake air flow through air filter. Service air filter elements as soon as possible. (See Service Air Cleaner in Service section.)

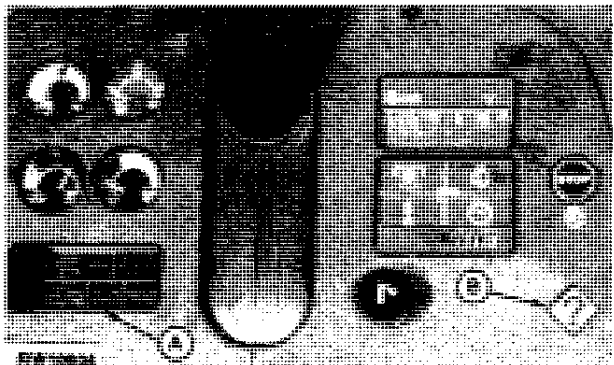

AJ8;RW10604 U01;CI17 X2 041084

WATCH TRANSMISSION FILTER RESTRICTION INDICATOR

"TRANS FILTER" indicator (A) and "Service Alert" signal (B) glow if transmission filter becomes partially plugged. Upon receiving warning signal, replace transmission filter as soon as possible. If filter is not replaced and restriction increases, red "Stop Engine" signal (C) flashes and warning horn sounds. Stop tractor immediately and replace filter. (See Lubrication and Maintenance section.) If filter replacement does not solve problem, see your John Deere dealer.

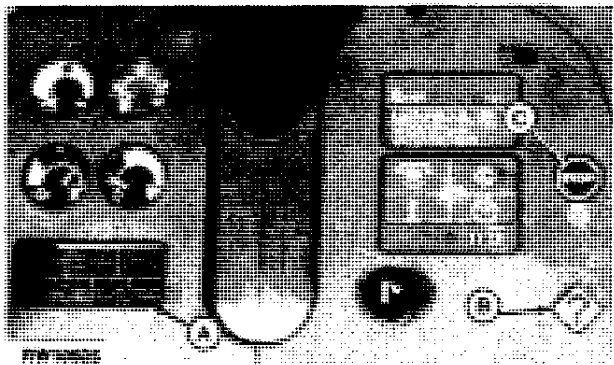

AJ8;RW10605 U01;CI18 X2 041084

<https://www.ebooklibonline.com>

Hello dear friend!

Thank you very much for reading.

Enter the link into your browser.

The full manual is available for immediate download.

<https://www.ebooklibonline.com>