

**8850
TRACTOR
(SERIAL NO. 006501-)**



JOHN DEERE

**OPERATORS MANUAL
8850 TRACTOR
(SERIAL NO. 006501-)**

OMRW22395 K5 English

**JOHN DEERE TRACTOR WORKS
OMRW22395 K5**

LITHO IN THE U.S.A.
ENGLISH



Introduction

Read This Manual carefully to learn how to operate and service your tractor correctly. Failure to do so could result in personal injury or equipment damage.

This manual should be considered a permanent part of your tractor and should remain with the tractor when you sell it.



This safety-alert symbol means ATTENTION! BECOME ALERT! YOUR SAFETY IS INVOLVED!

When you see this symbol on your machine or in your manual, be alert to the possibility of personal injury or death. Follow the instructions in the safety message.

Measurements in this manual are U.S. customary units and their metric equivalents.

Right-hand and left-hand sides are determined by facing in the direction of forward travel.



Worldwide symbols are used to assist identification and operation. In this manual, an identifying symbol is placed by the instructions like the example above for the symbol on the engine oil pressure gauge. The cylinder block in the symbol represents the engine, the drop signifies oil, and the arrows indicate pressure. Regardless of the language used in a nation, this symbol means engine oil pressure without translation.

Warranty on this machine appears on your copy of the purchase order which you should have received from your dealer when making your purchase. This warranty provides you the assurance that John Deere will back its products where defects appear within the warranty period. In some circumstances, John Deere also provides field improvements, often without charge to the customer, even if the product is out of warranty.

Warranty and field improvements are a part of John Deere's product support program for customers who operate and maintain their equipment as described in this manual. Should the equipment be abused or modified to change its performance beyond the original factory specifications, the warranty will become void and field improvements denied. Setting fuel delivery above specifications or otherwise overpowering machines will result in such action.

The tire manufacturer's warranty supplied with your machine may not apply outside the U.S.

Record the Product Identification Number(s) in the space provided following Specifications. Accurately record all of the characters because (should the product be stolen) tracing is sometimes through a computer match of letters and numbers. Also, your dealer needs this information when ordering parts. If you carry your operator's manual on the machine for reference, be sure to also record the identification number(s) on a separate sheet of paper and file it in a secure place not on the machine so you will still have a record in case the machine is stolen.

All information, illustrations and specifications in this manual are based on the latest product information available at the time of publication. The right is reserved to make changes at any time without notice.

Contents

Safety Signs	05-1	Remote Hydraulic Cylinders	
Safety	10-1	Hose Tips	55-1
Controls and Instruments		Identifying SCV	55-1
Control Location	15-1	Connecting Cylinder Hoses	55-2
Instrument Identification	15-1	Operating SCV	55-4
Gauges and Indicators Description	15-3	Setting Remote Cylinder Stroke	55-7
Tachometer	15-7	Disconnecting Cylinder Hoses	55-8
Lighting and Signals		Adjusting SCV Linkage	55-8
Switch	20-1	Drawbar and PTO	
Lamps and Signals	20-1	Drawbar Adjustments	60-2
Electrical Outlets	20-3	Power Take-Off (PTO)	60-5
Operator's Station		Ballast	
SOUND-GARD Body® Temperature		Importance of Ballast	65-1
Controls	25-1	Measuring Wheel Slip	65-2
Window Wipers and Washers	25-3	Determining Ballast	65-3
Windows	25-4	Wheels, Tires and Treads	
Radio	25-5	Wheel Tightening	70-1
Seat	25-6	Tread Settings	70-3
Steering Wheel	25-10	Wheel Adjustment	70-4
Engine Break-in	30-1	Steering Stops	70-7
Prestarting Checks	35-1	Axle Stops	70-8
Operating the Engine		Inflation Pressure	70-8
Start-up Procedure	40-3	Transporting	
Cold Weather Starting	40-5	Driving	75-1
Starting Aids	40-5	Carrier	75-2
Warm-Up and Operation	40-8	Towing	75-3
Stopping the Engine	40-10	Fuels and Lubricants	
Operating the Tractor		Fuel	80-1
Brakes	45-1	Engine Oil	80-2
Differential Lock	45-1	Transmission-Hydraulic Oil	80-3
QUAD-RANGE Transmission	45-2	Lubricants	80-4
Rockshaft and 3-Point Hitch		Lubricant Storage	80-5
Component Identification	50-2	Lubrication and Maintenance	
Rockshaft Control Lever	50-2	First 100 Hours	85-2
Rockshaft Selector Lever	50-4	10 Hour	90-1
Speed of Drop	50-6	200 Hour	95-1
Sway Blocks	50-6	600 Hour	100-1
Hitch Conversion	50-7	1200 Hour	105-1
Attaching Implement Hitch	50-9	Annual	110-1
Adjusting Implement Level	50-11	2 Year	115-1
Removing Implement	50-11	As Required	120-1

Continued on next page

<https://www.ebooklibonline.com>

Hello dear friend!

Thank you very much for reading.

Enter the link into your browser.

The full manual is available for immediate download.

<https://www.ebooklibonline.com>

Contents

Troubleshooting

Engine 125-1
Transmission 125-4
Hydraulic System 125-5
Brakes 125-6
Rockshaft 3-Point Hitch 125-6
Remote Hydraulic Cylinders 125-7
Electrical 125-8
SOUND-GARD® Body 125-10

Service

Access 130-1
Air Cleaner 130-3
Fuel System 130-6
Cooling System 130-8
Belts 130-13
Electrical 130-16
Circuit Breakers 130-19
Lighting 130-20
Brakes 130-26
Heating 130-29
Air Conditioner 130-30
Rollover Protective Structure 130-34

Storage

Placing Tractor in Storage 135-1
Removing Tractor From Storage 135-3

Crime Prevention Tips 140-1

Specifications

General 145-1
Ground Speeds 145-3

Identification Numbers

Identification Plates 150-1

Daily Maintenance 155-1

Lubrication and Maintenance Records

200 Hour Service 160-1
600 Hour Service 160-5
1200 Hour Service 160-6
Annual Service 160-7
Two Year Service 160-7
As Required Service 160-8

Index 165-1

Service Literature Form



John Deere 8850 Tractor

AJ7;RW8070 U01;CON02 X2 201185

Safety Signs

RECOGNIZE SAFETY INFORMATION

This is the safety-alert symbol. When you see this symbol on your machine or in this manual, be alert to the potential for personal injury.



AB6;T81389 053;ALERT 071085

UNDERSTAND SIGNAL WORDS

A signal word—DANGER, WARNING, or CAUTION—is used with the safety-alert symbol. DANGER identifies the most serious hazards.

Safety signs with signal word DANGER or WARNING are typically near specific hazards.

General precautions are listed on CAUTION safety signs. CAUTION also calls attention to safety messages in this manual.



AB6;TS187 053;SIGNAL 071085

FOLLOW SAFETY INSTRUCTIONS

Carefully read all safety messages in this manual and on your machine safety signs. Follow recommended precautions and safe operating practices.

Keep safety signs in good condition. Replace missing or damaged safety signs.



AB6;TS188 053;SIGNS 071085

STAY CLEAR OF PTO

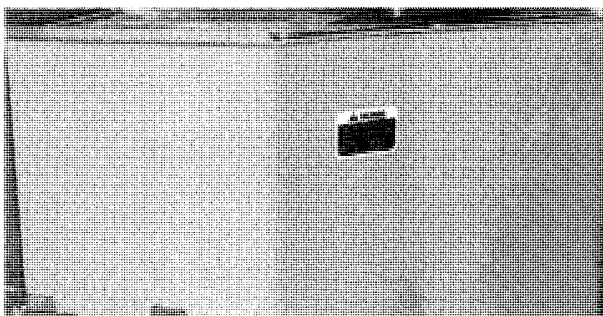

TO AVOID BODILY INJURY:

1. Keep PTO master shield and all power drive system safety shields in place.
2. When operating PTO driven implements, install drawbar in the down position if offset, and use the following drawbar instructions:

PTO Shaft	PTO Shaft End to Hitch Pin Hole
540 rpm - 6 spline	14.00 in. (356 mm)
1000 rpm - 21 spline	16.00 in. (407 mm)
* 1000 rpm - 20 spline	20.00 in. (508 mm)
* 1.75 in. (44.5 mm) dia. shaft	

AJ7;RW1098 5,RW1095 0 U01;READ SIGN2 311085

PREVENT MACHINE RUNAWAY

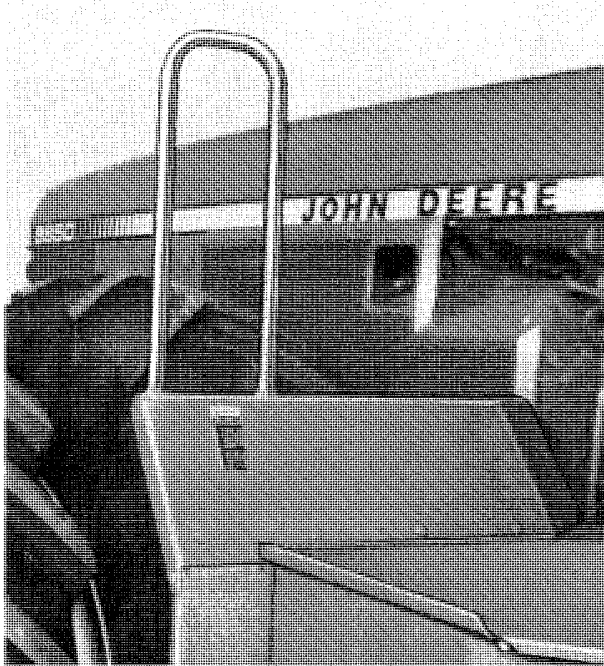

WARNING

AVOID POSSIBLE INJURY OR DEATH FROM A MACHINE RUNAWAY.

1. Do not start engine by shorting across starter terminals. Machine will start in gear if normal starting circuitry is bypassed.
2. Start engine only from operator's seat with transmission in neutral or park. **NEVER** start engine while standing on ground.

AJ7/RW1116 7,RW1095 1,U01;READ SIGN3A 211185

STAY CLEAR OF MOVING TRACTOR

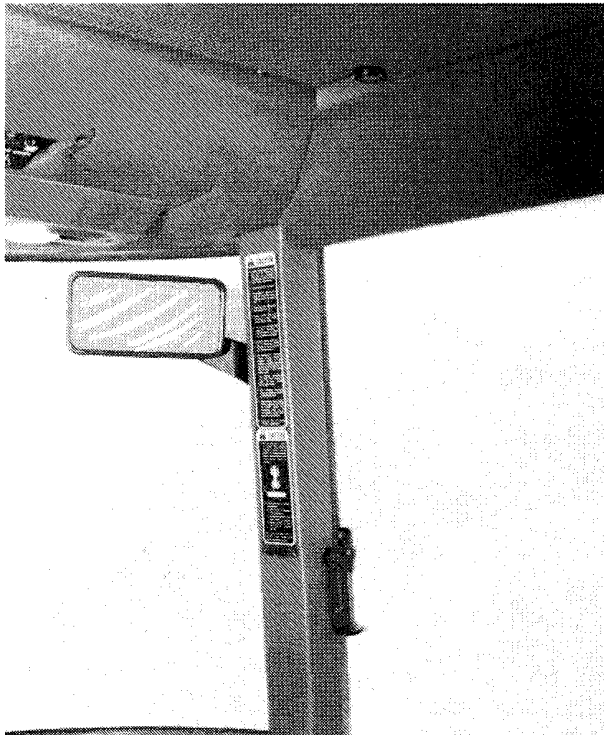

CAUTION

1. Be sure everyone is clear of tractor and attached equipment before starting engine or moving steering wheel because tractor and equipment move as pictured



2. Install lock-bars on tractor hinge before:
 - a. operating stationary PTO equipment.
 - b. performing service work near center of tractor
 - c. lifting tractor or transporting on another vehicle

Be sure lock bars are removed from hinge area before operating tractor.

AJ7/RW1098 7,RW1095 2L U01;READ SIGN4 311085

Safety Signs

AVOID HIGH-PRESSURE FLUID

Safety sign is located on brake accumulator line inside control support on right-hand side.

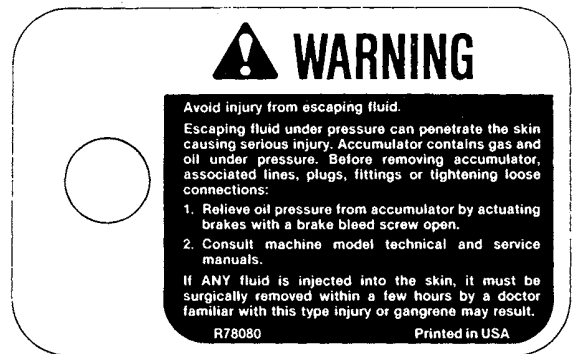

AJ7;RW1095 3 U01;READ SIGN5 010885

AVOID ESCAPING FLUID

Safety sign is located on brake accumulator inside control support on right-hand side.

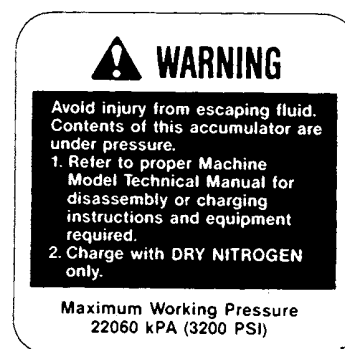

AJ7;RW1101 1 U01;READ SIGN12 080885

COUPLE IMPLEMENT SECURELY

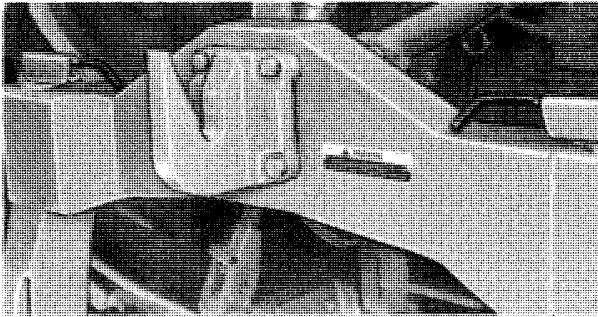

AJ7;RW1116 8,RW1095 4 U01;READ SIGN6A 211185

OPERATE TRACTOR SAFELY

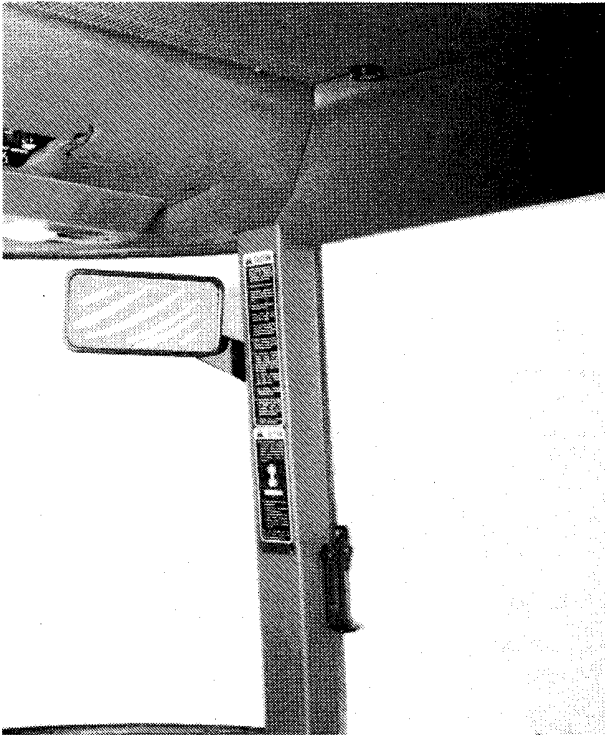

CAUTION

1. Before operating this tractor, read the Operator's Manual for complete operating instructions and safety information.
2. Keep all shields in place.
3. Make certain everyone is clear of machine before starting engine or operation.
4. Keep all riders off tractor and equipment.
5. Keep hands, feet and clothing away from power driven parts.
6. Use of seat belt with this protective structure is recommended for almost all operating conditions.
7. Reduce speed when turning or operating around hazards, on rough ground or on steep slopes.
8. Be especially careful when using single wheels. Danger of an overturn increases greatly with narrow tread (2 m [80 inches] or less) and high speed.
For hillside operation, use only dual wheels, front and rear. Avoid sharp uphill turns.
9. Use flashing warning lights on highway unless prohibited by law.
10. Stop engine, lower implement to ground and shift to "PARK" before dismounting. Wait for all movement to stop before servicing machinery.
11. Remove key if leaving tractor unattended.

AJ7;RW1098 7, RW1095 5 U01;READ SIGN7 311085

Safety

LEARN MACHINE SAFETY

Carefully read this manual. Learn how to operate the machine and how to use the controls properly.

Do not let anyone operate this machine without proper instruction.

Unauthorized modifications to the machine may impair the function and/or safety and affect machine life.

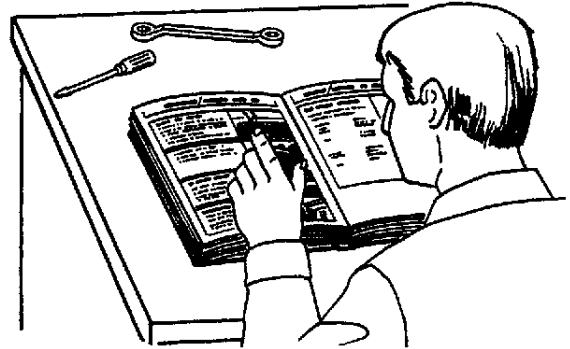

AB6;TS183 053;READ2 080785

EMERGENCY EXIT

Make an emergency exit out the SOUND-GARD® body window by removing quick-lock pins (A) and headed pins (B) from window latches and pushing window wide open.

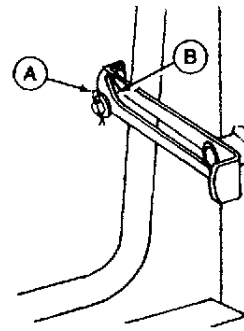

AJ7;RW4420 U01;EXIT 090585

PREVENT MACHINE RUNAWAY

Avoid possible injury or death from machinery runaway.

Do not start engine by shorting across starter terminals. Machine will start in gear if normal circuitry is by passed.

NEVER start engine while standing on ground. Start engine only from operator's seat, with transmission in neutral or park.

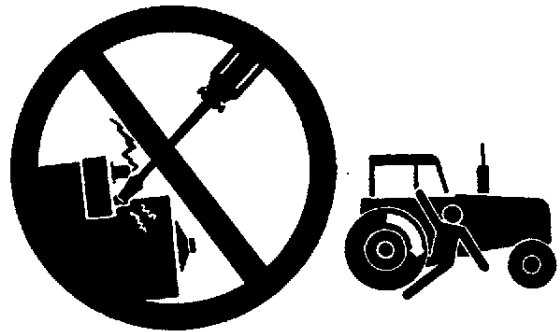

AB6;TS177 053;BYPAS1 210585

SHIFT TO LOW GEAR ON HILLS

Shift to a low gear (B) before descending a steep hill (A), to improve your control of the tractor with little or no braking. Never coast downhill.

When driving on icy or graveled surfaces, reduce speed and be sure tractor is properly ballasted to avoid skidding and loss of steering control.

Additional ballast may be needed for transporting heavy integral implements. When implement is raised, drive slowly over rough ground, regardless of how much ballast is used.

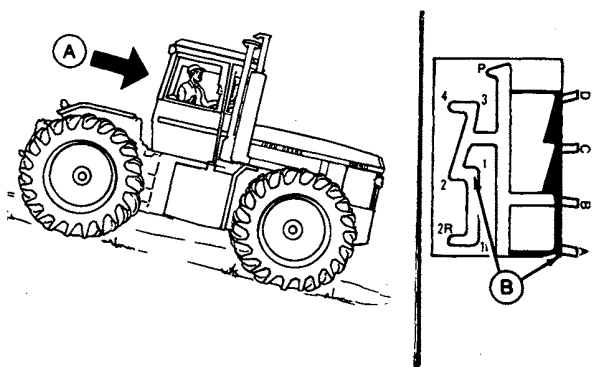

AJ7;RW4421 U01;DRIVE SAFE 281085

USE CAUTION ON HILLSIDES

Avoid holes, ditches, and obstructions which may cause the tractor to tip, especially on hillsides.

Never drive near the edge of a gully or steep embankment—it might cave in.

Be especially careful when using single wheels. The danger of an overturn increases greatly with narrow tread 80 in. (2032 mm) or less and high speed.

For hillside operation, always use front and rear dual wheels (A). Avoid sharp, uphill turns.

Keep transmission-hydraulic oil level at upper mark on dipstick (B) when operating on hillsides. Low oil level might result in loss of steering and clutch engagement. If this should happen, hold tractor with brakes, shift to PARK, stop engine, and add hydraulic oil to proper level.

Before operating on extremely steep slopes, fill transmission-hydraulic system beyond overfull mark on dipstick 1 to 2 gal. (4 to 8 L). This is particularly important when using large hydraulic cylinders, due to the volume of oil used to extend them.

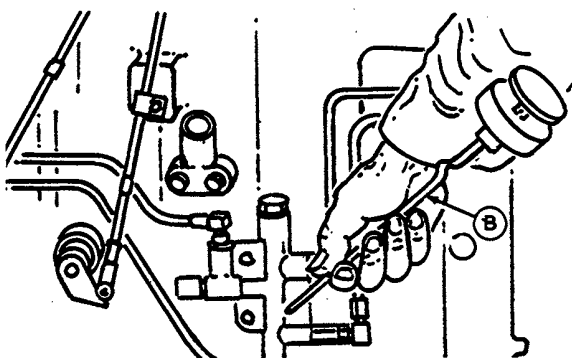
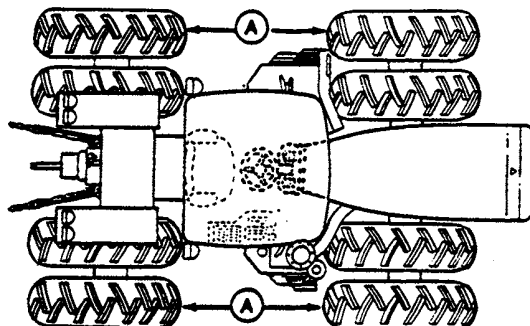

AJ7;RW8077,RW1035 6 U01;HILL SIDE 051185

COUPLE IMPLEMENT SECURELY

Securely couple implement by pushing sheet metal base of both hand latch controls down against turned up edge of latch rod brackets.

Secure draft link attaching pins by tightening retainer screws to 85 lb-ft (115 N·m).

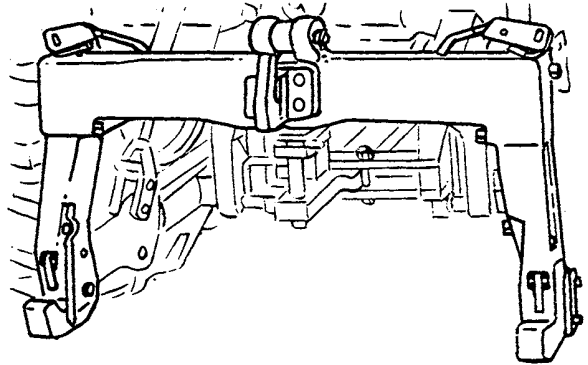

AJ7;RW1095 6 U01;COUPLE SECURE 200585

AVOID EXHAUST FUMES

Never run engine in a closed building. Make sure service area is adequately ventilated.

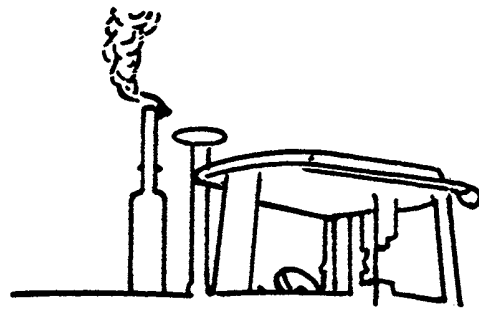

AJ7;RW8075 U01;AVOID FUMES1 311085

KEEP RIDERS OFF MACHINE

Only allow the operator on the machine. Keep riders off.

Riders on machine are subject to injury such as being struck by foreign objects and being thrown off of the machine. Riders also obstruct the operator's view resulting in the machine being operated in an unsafe manner.



AB6;TS173 053;RIDER 261184

MAKE TRACTOR VISIBLE ON HIGHWAY

Turn light switch to "H" position. Never use white lights which are visible from the rear. Always dim head lamps before meeting another vehicle. Keep head lamps properly adjusted.

Add SMV emblem, reflectors, and auxiliary lighting to equipment as required for safety and by local regulations.

Before operating tractor on highway, be sure flashing warning lamps work properly. Adjust rear view mirror, and clean windows and SMV emblem.

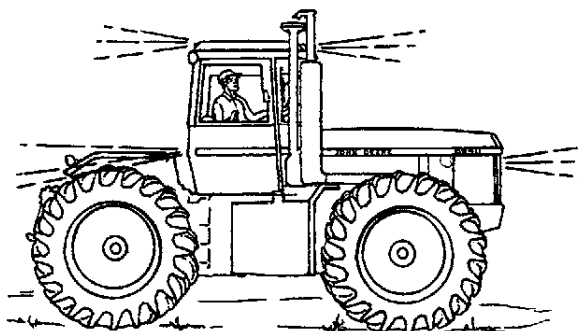

AJ7;RW4423 U01;USE LIGHT 051185

Safety

HANDLE FUEL SAFELY—AVOID FIRES

Handle fuel with care: it is highly flammable. Do not refuel the machine while smoking or when near open flame or sparks.

Always stop engine before refueling machine. Fill fuel tank outdoors.

Prevent fires by keeping machine clean of accumulated trash, grease, and debris. Always clean up spilled fuel.



AB6;TS185 053;FIRE1 240785

PREPARE FOR EMERGENCIES

Be prepared if a fire starts.

Keep a first aid kit and fire extinguishers handy.

Keep emergency numbers for doctors, ambulance service, hospital, and fire department near your telephone.



AB6;TS186 053;FIRE2 080785

HANDLE STARTING FLUID SAFELY

Starting fluid is highly flammable.

Keep all sparks and flame away when using it. To prevent accidental discharge when storing the pressurized can, keep the cap on the container, and store in a cool, protected location.

Do not incinerate or puncture a starting fluid container.



AB6;T6089A U 053;FIRE3 080785

PREVENT BATTERY EXPLOSIONS

Battery gas can explode. Keep sparks and flames away from batteries. Use a flashlight to check battery electrolyte level.

Never check battery charge by placing a metal object across the posts. Use a voltmeter or hydrometer.

Always remove grounded (-) battery clamp first and replace it last.

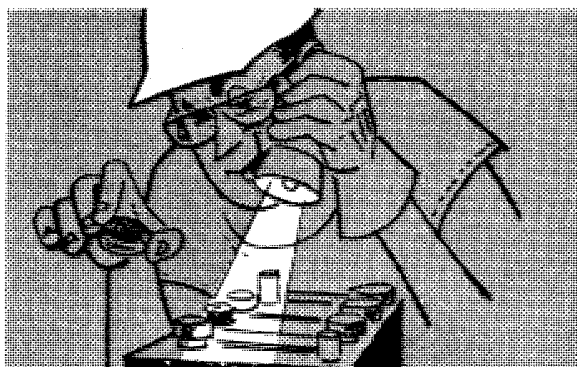

AB6;TS181 053;EXPL0 180485

AVOID ACID BURNS

Sulfuric acid in battery electrolyte is poisonous. It is strong enough to burn skin, eat holes in clothing, and cause blindness if splashed into eyes.

Avoid the hazard by:

1. Filling batteries in a well-ventilated area.
2. Wearing eye protection and rubber gloves.
3. Avoiding breathing fumes when electrolyte is added.
4. Avoiding spilling or dripping electrolyte.

If you spill acid on yourself:

1. Flush your skin with water.
2. Apply baking soda or lime to help neutralize the acid.
3. Flush your eyes with water for 10-15 minutes. Get medical attention immediately.

If acid is swallowed:

1. Drink large amounts of water or milk.
2. Then drink milk of magnesia, beaten eggs, or vegetable oil.
3. Get medical attention immediately.

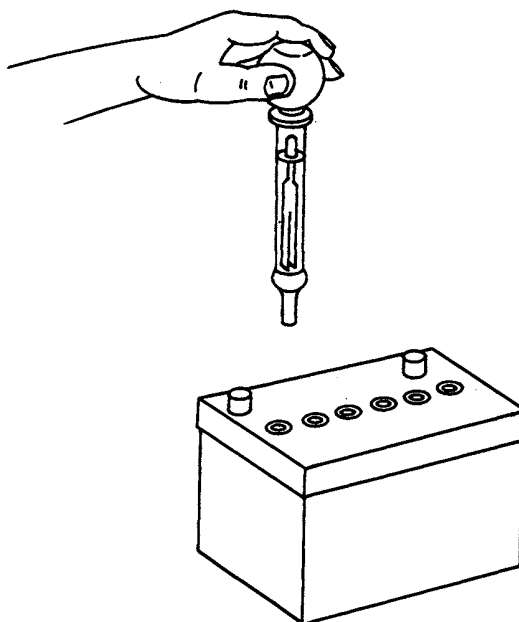

AB6;TS182 053;ACID 180485

PROTECT AGAINST NOISE

Prolonged exposure to loud noise can cause impairment or loss of hearing.

Wear a suitable hearing protective device such as earmuffs (A) or earplugs (B) to protect against objectionable uncomfortable loud noises.

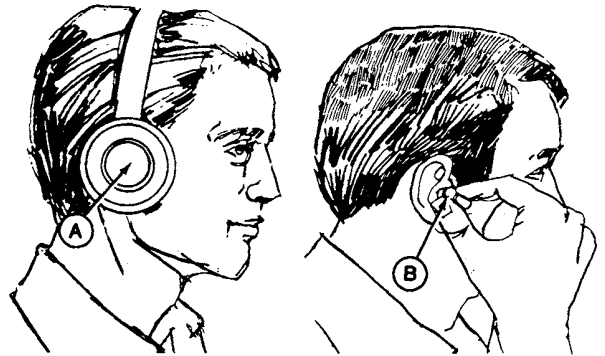

AB6;X7662 053;NOISE 150584

USE SEAT BELT PROPERLY

Use a seat belt when you operate with a roll-over protective structure (ROPS) to minimize chance of injury from an accident such as an overturn.

Do not use a seat belt if operating without a ROPS.

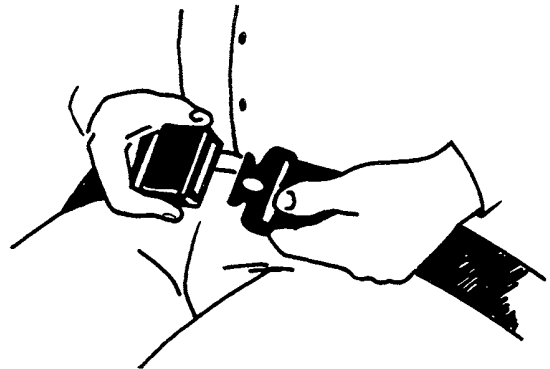

AB6;TS175 053;ROPS1 261184

HANDLE CHEMICALS PROPERLY

SOUND-GARD body air filters (A) are not designed to filter out harmful chemicals. Follow instructions given in the implement operator's manual and those given by the chemical manufacturer when using agricultural chemicals.

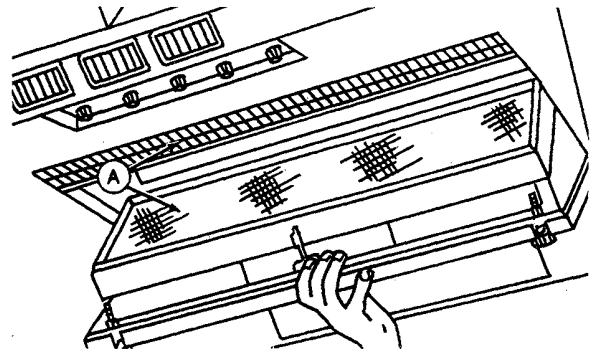

AJ7;RW5704 L U01;HANDLE CHEM 090585

WEAR PROTECTIVE CLOTHING

Wear fairly tight clothing and safety equipment.



AB6;TS184 053;WEAR2 080785

STAY CLEAR OF MOVING TRACTOR

Always place transmission in PARK before dismounting. Leaving transmission in gear with engine stopped will NOT prevent the tractor from moving.

Be sure everyone is clear of tractor and attached equipment before starting engine or moving steering wheel. Tractor and equipment move (A), even with transmission in PARK. Some steering movement often occurs as engine starts.

Never try to get on or off a moving tractor.

When tractor is left unattended, lower implements to the ground, stop the engine, and remove the key.

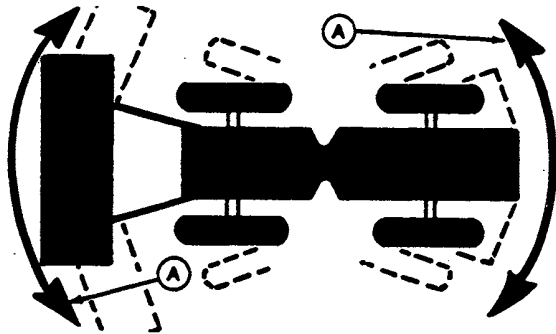

AJ7;RW8078 U01;STAY CLEAR1 281085

STAY CLEAR OF PTO

Stop the engine and be sure the PTO drive line has stopped before:

- Connecting or disconnecting implement drive line
- Making adjustments on the implement
- Cleaning out PTO driven equipment

PTO master shield (A) and drive line shields should be in place at all times except for special applications as directed in the implement operator's manual.

Install lock bars in tractor hinge before operating stationary PTO equipment. Be sure lock bars are removed before driving tractor.

Operate PTO at recommended speed.

Avoid loose-fitting or dangling clothing.

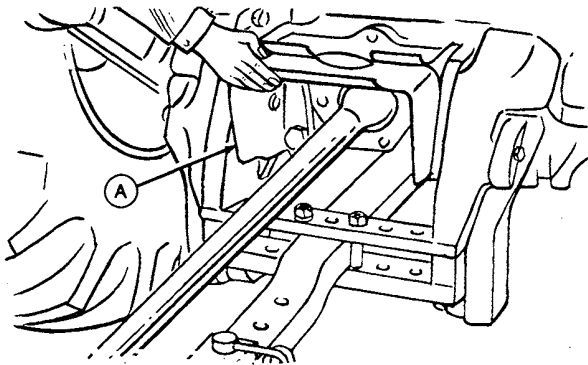

AJ7;RW4424 U01;PTO 1 250285

USE A SAFETY CHAIN

A safety chain will help control drawn equipment (B) should it accidentally separate from the drawbar (A) while transporting. Using the appropriate adapter parts, attach the chain to the tractor drawbar support or other specified anchor location. Provide only enough slack in the chain to permit turning. See your John Deere dealer for a chain with a strength rating equal to or greater than the gross weight of the towed machine.

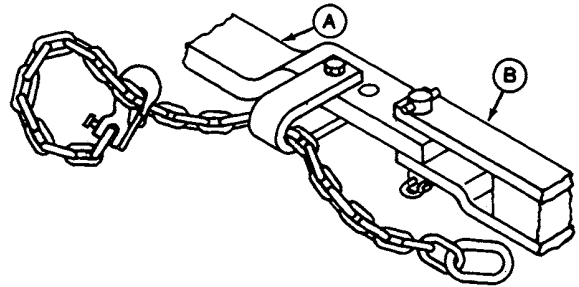

AB6;TS163 053;CHAIN 310884

TRANSPORT TRACTOR SAFELY

The best method for transporting a disabled tractor is to haul it on a flatbed carrier.

If towing a tractor, never tow faster than 10 mph (16 km/h) with rear wheels raised or faster than 5 mph (8 km/h) with all wheels on the ground. (See Towing in Transporting section.) When possible, have an operator steer and brake tractor.

Use of radial tires requires special precautions. (See Using Radial-Ply Tires in Wheels, Tires and Treads section.)

U01;HAUL IT1 051185

TOW EQUIPMENT PROPERLY

Use caution when towing loads at transport speeds. Reduce speed if towed load weighs more than the tractor and is not equipped with brakes. Avoid hard braking applications. (Consult implement operator's manual for recommended transport speeds.)

Use additional caution when transporting towed loads under adverse surface conditions, when turning, or on inclines.

U01;TOW 061284

SERVICE TRACTOR SAFELY

Do not service the tractor while it is in motion or while the engine is running.

Stay clear of hinge area when engine is running. Stop engine and remove key before working near hinge.

Drive shaft does not turn at engine start-up until clutch pedal is depressed and released. Be aware of sudden rotation of drive shaft as clutch is actuated.

Install lock bars on tractor hinge before performing service work in hinge area. Be sure lock bars are removed before operating tractor.

The air conditioning system is pressurized. Improper servicing may cause refrigerant to penetrate eyes and skin or cause burns. Special equipment and procedures are required to service air conditioning system. (See your John Deere dealer.)

Reinstall all shields removed during service.

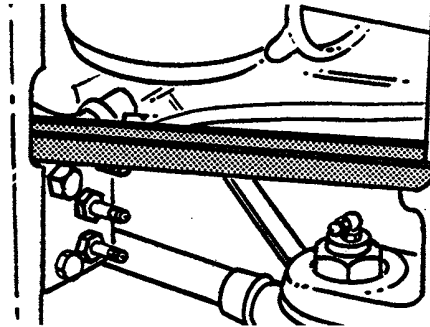

AJ7;RW8194 U01;WORK SAFE 311085

AVOID HIGH-PRESSURE FLUIDS

Escaping fluid under pressure can penetrate the skin causing serious injury. Relieve pressure before disconnecting hydraulic or other lines. Tighten all connections before applying pressure. Keep hands and body away from pinholes and nozzles which eject fluids under high pressure. Use a piece of cardboard or paper to search for leaks.

If ANY fluid is injected into the skin, it must be surgically removed within a few hours by a doctor familiar with this type injury or gangrene may result.

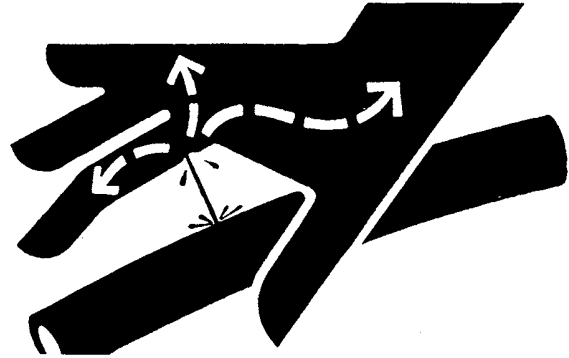

AB6;X9811 053;FLUID 100584

SERVICE COOLING SYSTEM SAFELY

Do not remove radiator cap (A) when engine is hot. Shut the engine off and wait until it cools. Then turn the cap slowly to the first stop to relieve pressure before removing it completely.

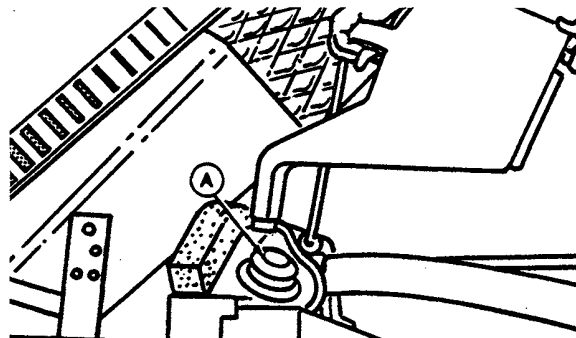

AJ7;RW8195 U01;COOL IT1 111185



Suggest:

If the above button click is invalid.

Please download this document

first, and then click the above link

to download the complete manual.

Thank you so much for reading

SERVICE TIRES SAFELY

Failure to follow proper procedures when mounting a tire on a wheel or rim can produce an explosion which may result in serious injury or death. Do not attempt to mount a tire unless you have the proper equipment and experience to perform the job. Have it done by your John Deere dealer or a qualified repair service.

When sealing tire beads on rims, never exceed 35 psi (240 kPa) (2.4 bar) or maximum inflation pressures specified by tire manufacturers for mounting tires. Inflation beyond this maximum pressure may break the bead, or even the rim, with dangerous explosive force. If both beads are not seated when the maximum recommended pressure is reached, deflate, reposition tire, relubricate bead, and reinflate.

Detailed agricultural tire mounting instructions, including necessary safety precautions, are contained in John Deere Fundamentals of Service (FOS) Manual 55, Tires and Tracks. Such information is also available from the Rubber Manufacturers Association and from tire manufacturers.

- A—Use a safety cage if available.
- B—Do not stand over tire. Use a clip-on chuck and extension hose.

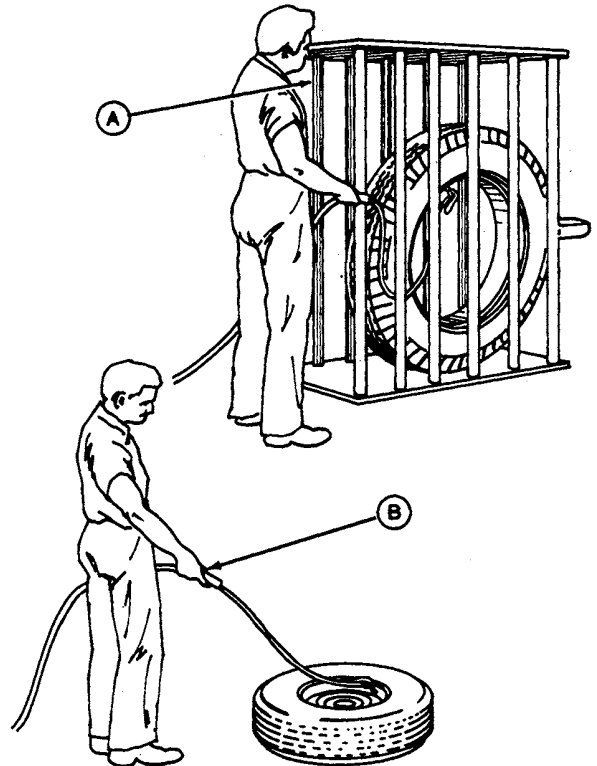

AJ7;TS0123 U01;FIX TIRES 090585

TEST COOLANT HEATER IN LIQUID ONLY

Do not plug coolant heater into electrical power unless heating element is immersed in coolant. Sheath could burst and result in personal injury.

Use a heavy-duty grounded cord to connect coolant heater to electrical power.

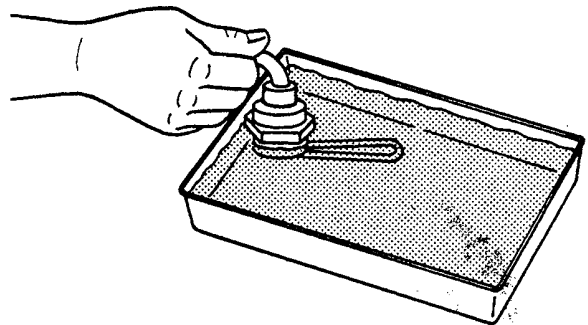

AB6;TS174 053;HEAT 110584

SERVICE BRAKE ACCUMULATOR SAFELY

Accumulator contains gas and oil under pressure. To avoid injury from escaping fluid, relieve all pressure from accumulator before disconnecting brake accumulator or brake valve. To do so open bleed screws and pump brake pedal with engine stopped, until pedal easily goes all the way down.

The accumulator is charged with dry nitrogen to a pressure of 500 psi (3450 kPa) (35 bar). If it needs recharging, have job done only by a qualified service person and only with dry nitrogen.

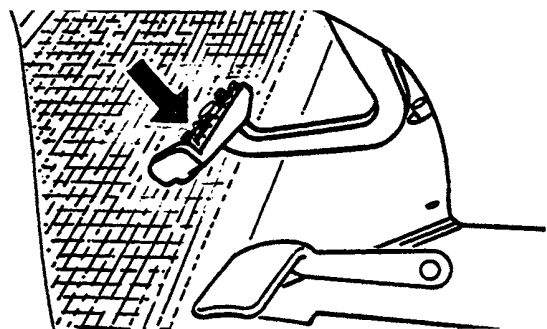

AC3;RW8103 U01;FIX BRAKE1 311085

<https://www.ebooklibonline.com>

Hello dear friend!

Thank you very much for reading.

Enter the link into your browser.

The full manual is available for immediate download.

<https://www.ebooklibonline.com>