



6601 COMBINE



JOHN DEERE

OPERATORS MANUAL 6601 COMBINE

OMH82644 E0 English

JOHN DEERE HARVESTER WORKS
OMH82644 E0

LITHO IN THE U.S.A.
ENGLISH

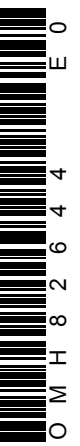



To the Purchaser

This new combine was carefully designed and manufactured to give years of dependable service. To keep it running efficiently, read the instructions in this operator's manual. Each section is clearly identified so you can easily find the information you need—whether it is operation, lubrication, or service. Read the Table of Contents to learn where each section is located. Use the alphabetical index for fast reference.

 This safety alert symbol identifies important safety messages in this manual. When you see this symbol, be alert to the possibility of personal injury and carefully read the message that follows.

In addition to the equipment furnished with your combine, attachments are available to help you do a better job in special crop conditions. These are described in the attachments section of this manual and can be purchased from your John Deere dealer.

"Right-hand" and "left-hand" sides are determined by facing in the direction the combine will travel when in use.

Record your combine serial numbers in the space provided on page 69. Your dealer needs this information to give you prompt, efficient service when you order parts or attachments. If your combine requires replacement parts, go to your John Deere dealer where you can obtain Genuine John Deere parts—accept no substitutes.

The warranty on this combine appears on your copy of the purchase order which you should have received from your dealer when you purchased the combine.

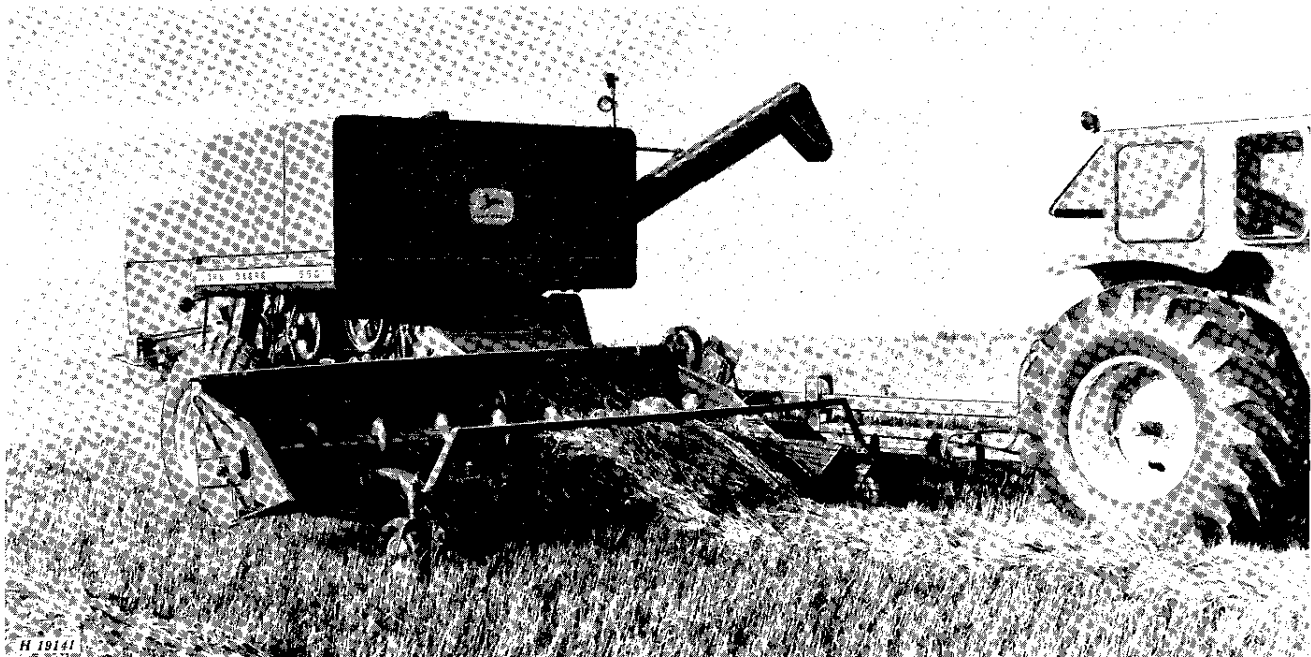



Contents

	Page
Controls and instruments	2
Operation	4
Safety suggestions	26
Lubrication and periodic service	27
Service	32
Trouble shooting	59
Storage	65
Attachments	66
Specifications	69
Index	71

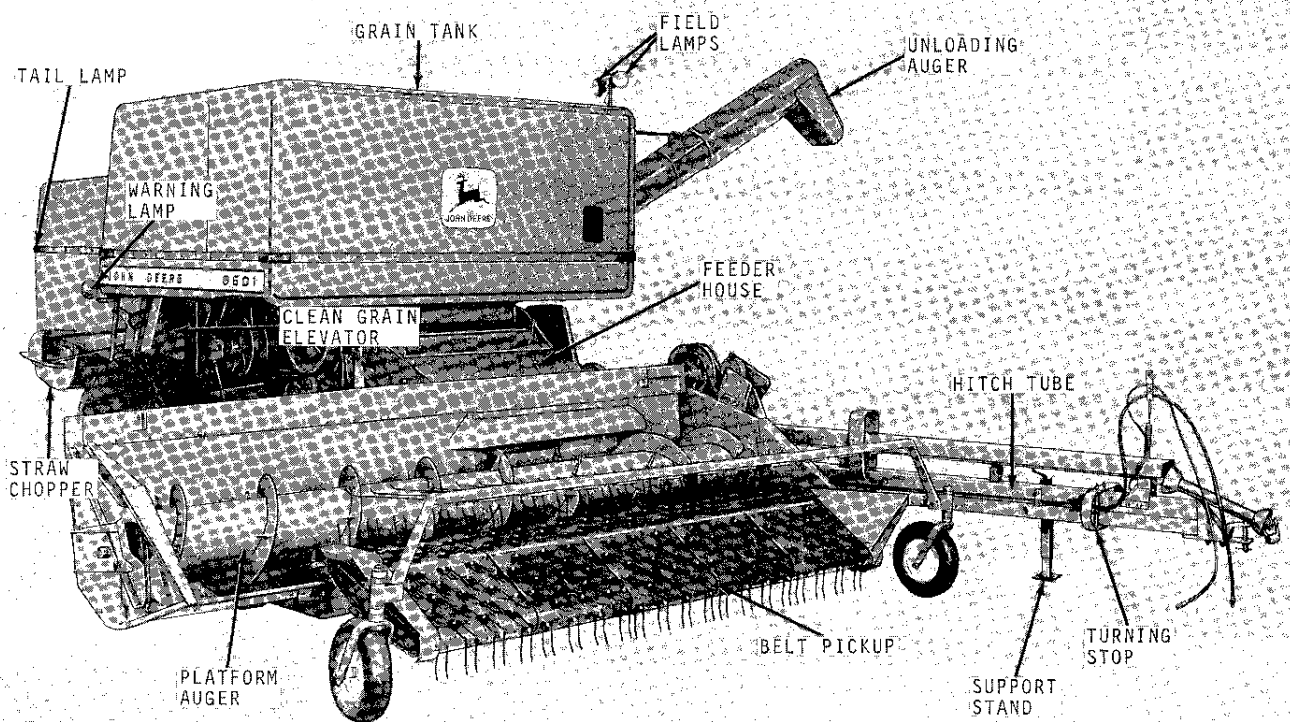

H 19142

John Deere 6601 Combine with Belt Pickup and Straw Chopper (Special Attachments)

<https://www.ebooklibonline.com>

Hello dear friend!

Thank you very much for reading.

Enter the link into your browser.

The full manual is available for immediate download.

<https://www.ebooklibonline.com>



Controls and Instruments

This section illustrates all controls and instruments necessary for successful field operation. For an explanation of each control and instrument, refer to the page reference given.

Before attempting to operate your new combine, become familiar with the location and purpose of its controls and instruments. Study these pages carefully, regardless of your previous combine experience.

SWITCH BOX

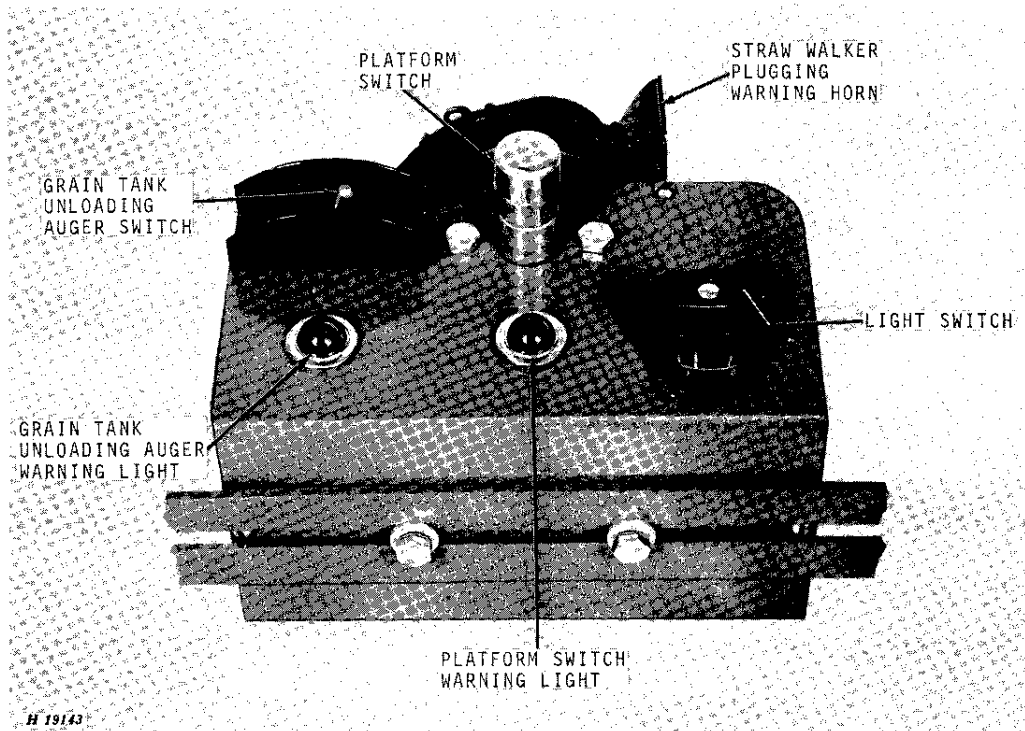

- Grain Tank Unloading Auger Switch - Page 21
- Grain Tank Unloading Auger Warning Light - Page 21
- Platform Switch - Page 11
- Platform Switch Warning Light - Page 11
- Straw Walker Plugging Warning Horn - Page 67
- Light Switch - Page 21

CONCAVE

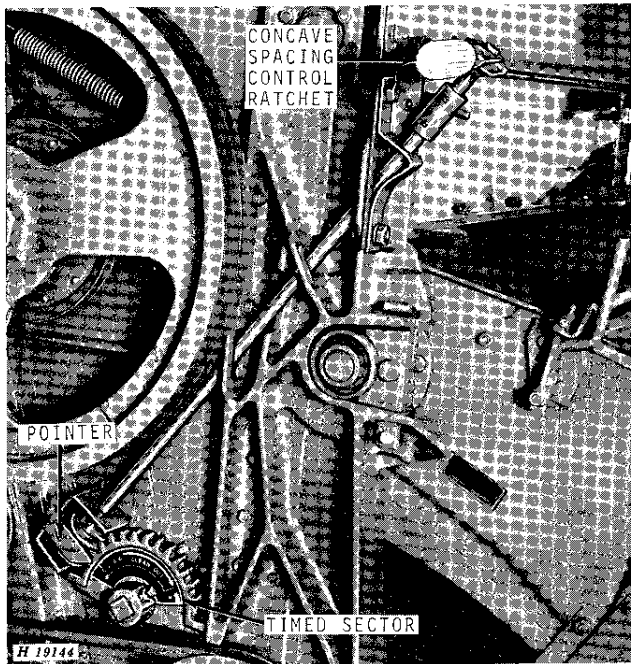

Concave Spacing Control Ratchet - Page 17

FAN

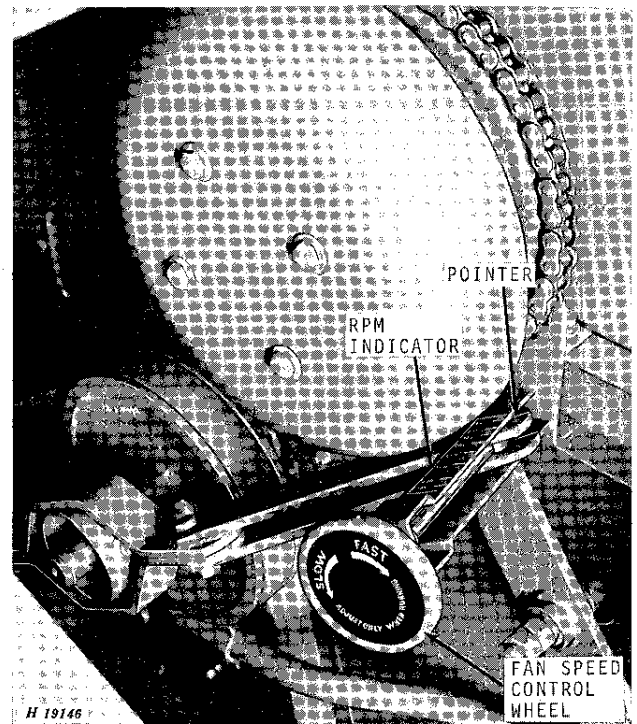

Cleaning Fan Speed Control Wheel - Page 18

CYLINDER

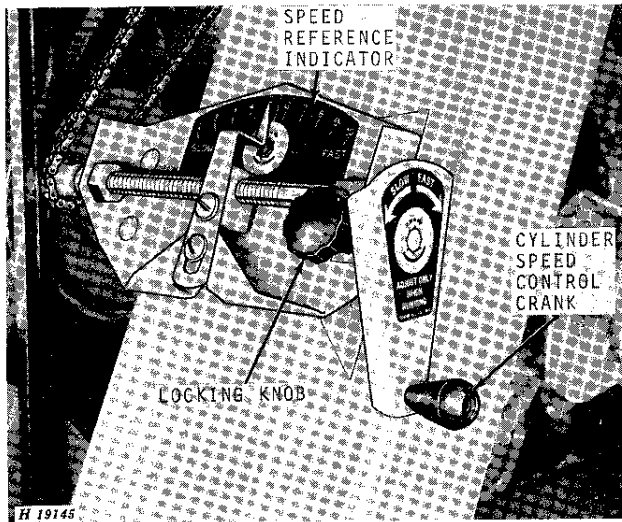

Cylinder Speed Control Crank - Page 16

CHAFFER AND SIEVE

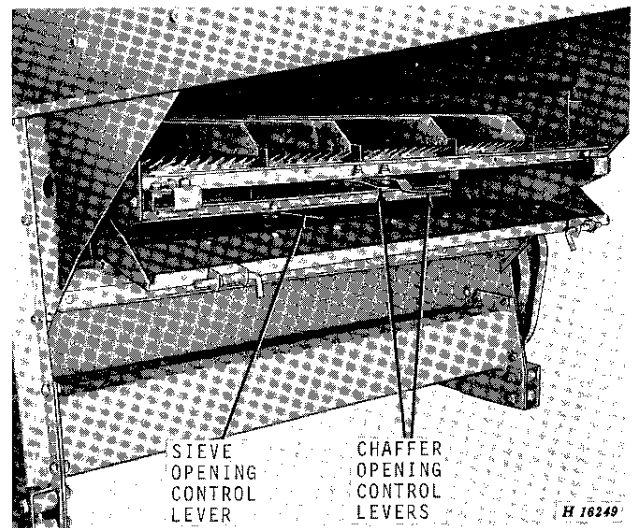

Sieve Opening Control Lever - Page 19
Chaffer Opening Control Levers - Page 19



Operation

TRACTOR HOOKUP

CAUTION: Operate the 6601 Combine at 1000 rpm PTO speed only. Operating the combine at any other PTO speed can result in machine damage or personal injury.

YOKE ASSEMBLY

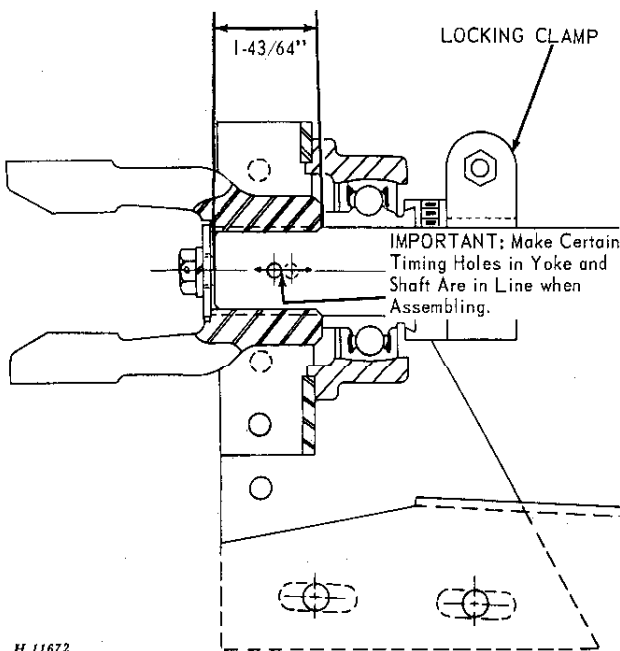

Should it become necessary to disturb locking clamp on hitch tube powershaft, make certain bearing and yoke assemblies are assembled on the shaft, using dimensions given in the illustration above for proper position. Failure to do so will cause misalignment of hookup parts.

IMPORTANT: Under normal circumstances, locking clamp should not be moved unless it becomes necessary to replace parts.

SWITCH BOX

The switch box is wired at the factory for tractors with a 12-volt electrical system or a split electrical system (24-volt starting).

Instructions for hookup of switch box wires are on pages 7 and 8.

Diode Panel

The diode panel in the switch box is wired for tractors with a negative-ground electrical system.

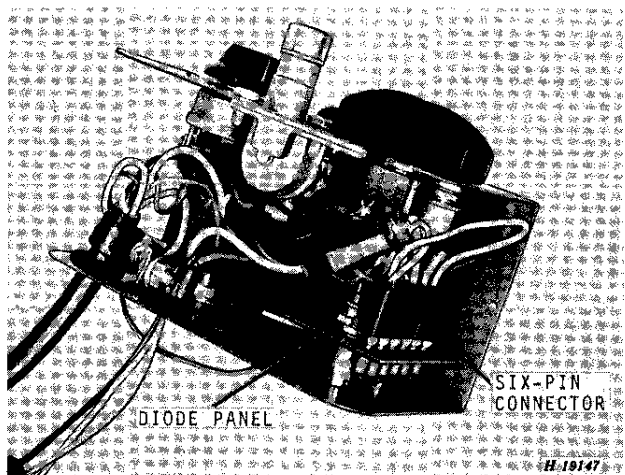

When using a tractor with a positive-ground electrical system, rotate the six-pin connector 180 degrees.

ATTACHING SWITCH BOX AND WIRING TO ALL TRACTORS WITHOUT CABS AND TO TRACTORS WITH CABS PRIOR TO 1968

If switch box and wiring have not already been installed on tractor, proceed as follows:

Switch Box

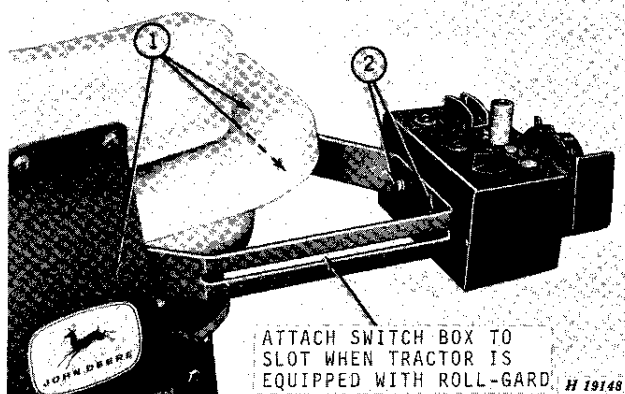

1. Secure switch box support bracket to seat frame, using existing hardware.

2. Secure switch box to support bracket, using two 1/4 x 1/2-inch cap screws.



be careful.....
avoid accidents

Harness Plate (Cabs Only)

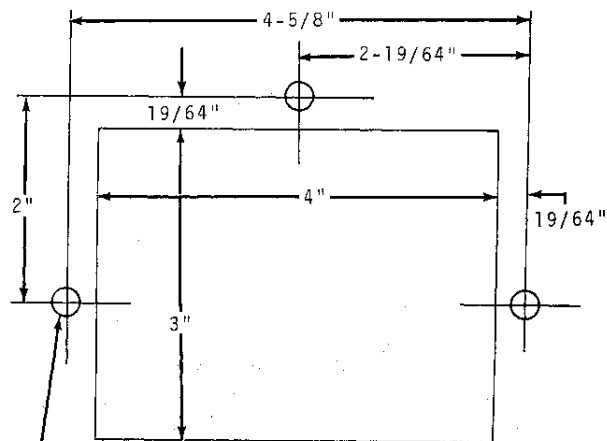
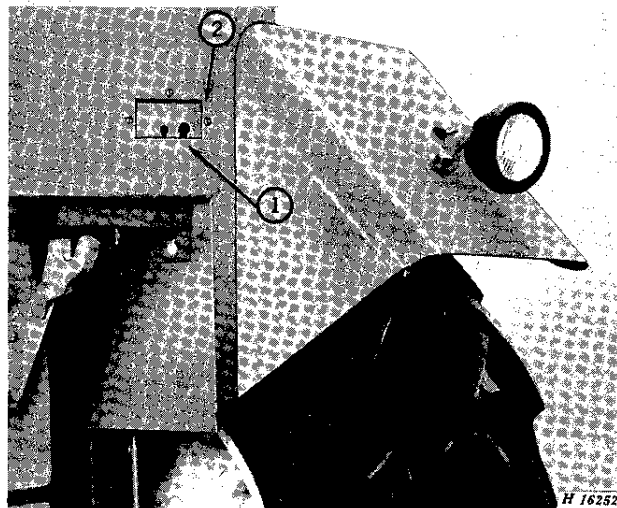

9/32" (3 HOLES)

H 16402

1. Cut and drill holes, to dimensions shown, in right-hand rear of cab.

2. Attach harness plate to cab, using three 1/4 x 7/8-inch truss head machine screws. Install grommets in harness plate.

3. (Not Illustrated) Run wires from switch box through holes in harness plate.

SWITCH BOX—Continued

Attaching Switch Box To Tractors with Cabs 1968 And Up

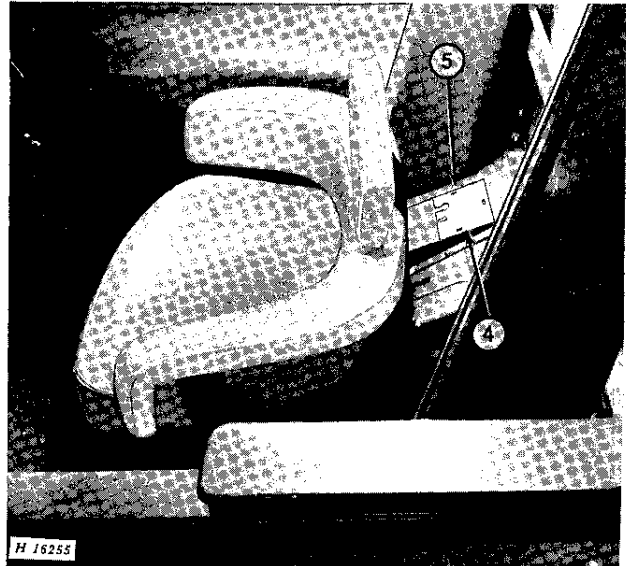
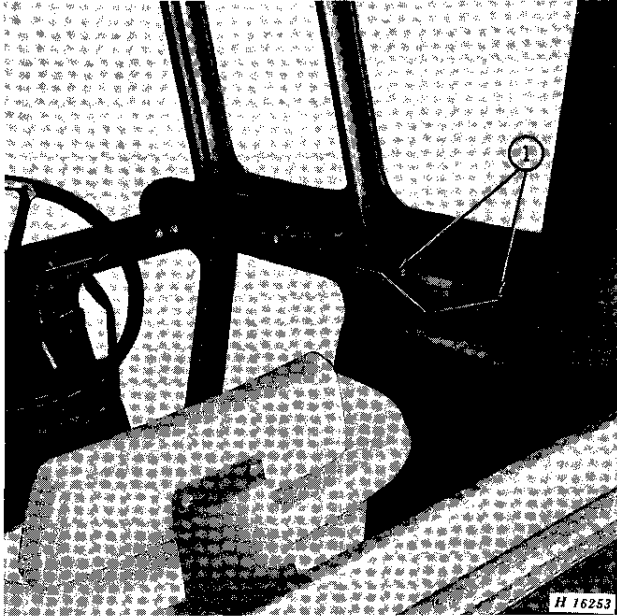

1. Secure switch box support bracket to cab, using existing hardware. On the 4520 Tractor the switch box support bracket will have to be mounted in the second and third hole from the front of the fender.

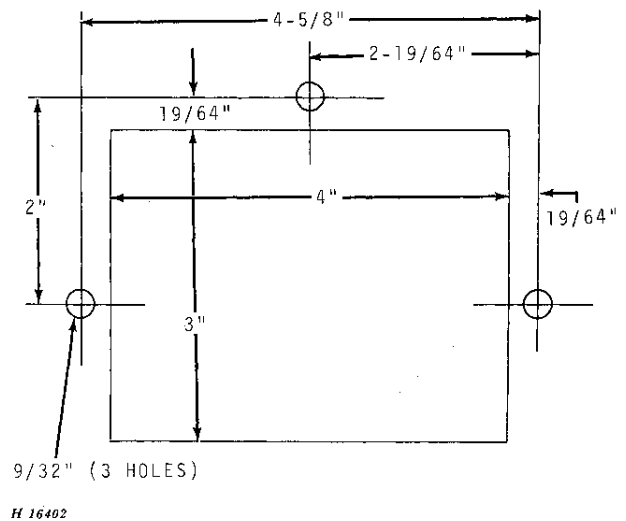
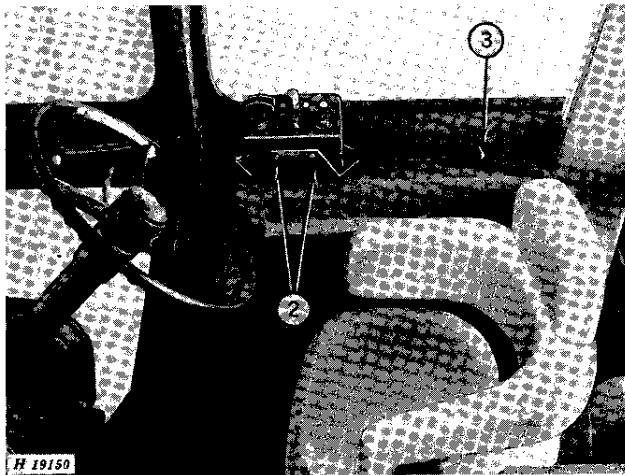

2. Secure switch box to bracket, using two 1/4 x 1/2-inch cap screws and two 9/32 x 5/8 x .060-inch flat washers.

3. Run wires from switch box through clip and attach clip to cab, using existing hardware.

4. Cut and drill holes, to dimensions shown, in right-hand rear deck of cab.

5. Attach harness plate to rear deck, using three 1/4 x 7/8-inch truss head machine screws. Install grommets in harness plate.

6. (Not illustrated) Run wires from switch box through holes in harness plate.

ATTACHING COMBINE TO TRACTOR

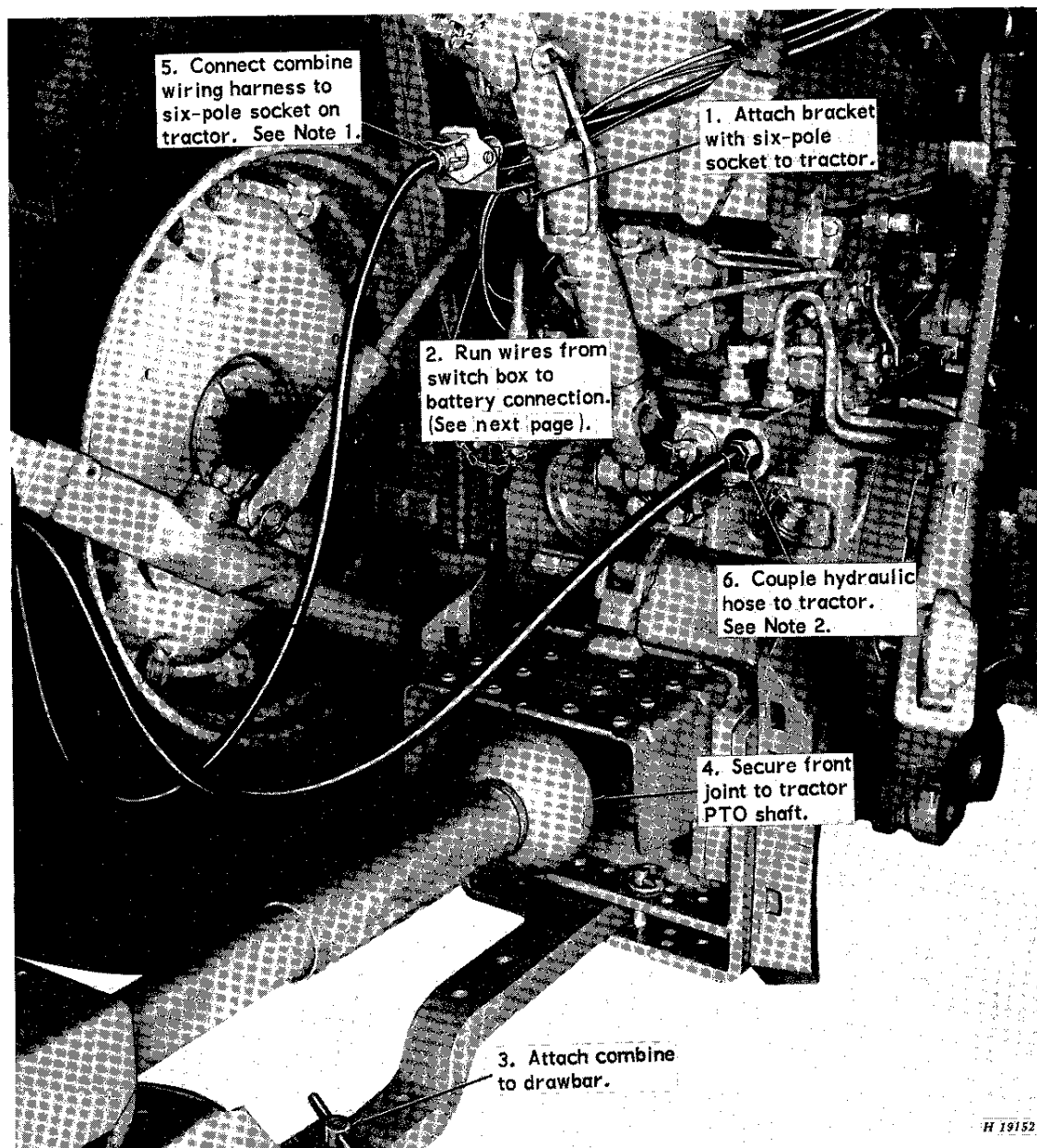

NOTE 1: To prevent accidental discharging of tractor batteries when tractor-combine hook-up is left unattended, disconnect six-pole plug from tractor.

NOTE 2: Adapt the tractor remote hydraulic cylinder valve housing for single-action cylinder operation. See tractor operator's manual. Couple hydraulic hose to tractor No. 1 hydraulic circuit breakaway coupler.

ATTACHING COMBINE TO TRACTOR—Continued

The illustrations below show wire connections between switch box and battery for various tractors. Also see step 2 on page 7.

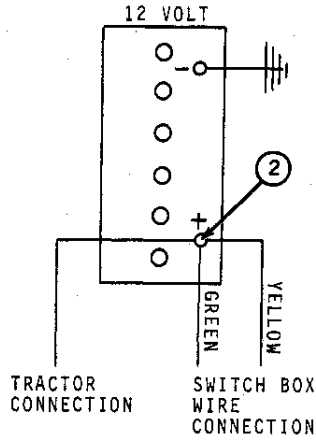

H 19153

Gasoline and LP-Gas
4010 - 4020

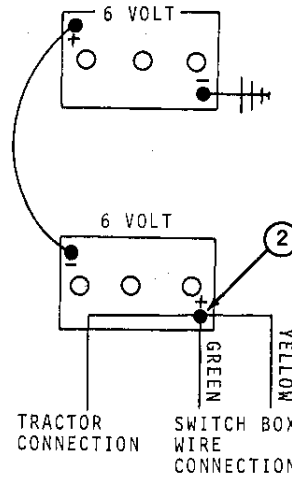

H 19154

Diesel
4000 - 4520
4020 (201,001-)

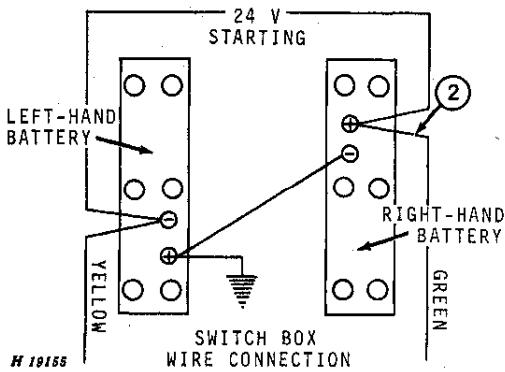

H 19155

Diesel
4010 - 4020 (-201000)

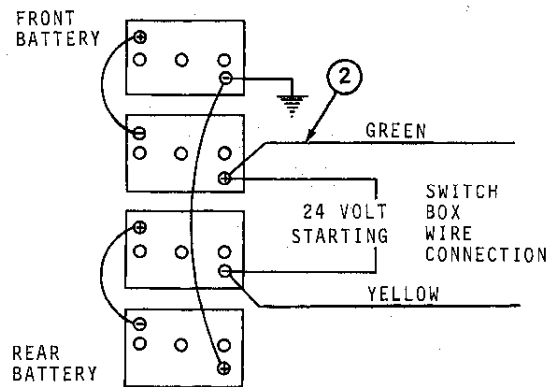

H 19156

Diesel
5010 - 5020

Hookup Adjustments

Adjust hitch plates, powershaft, tractor drawbar, and turning stops as shown below.

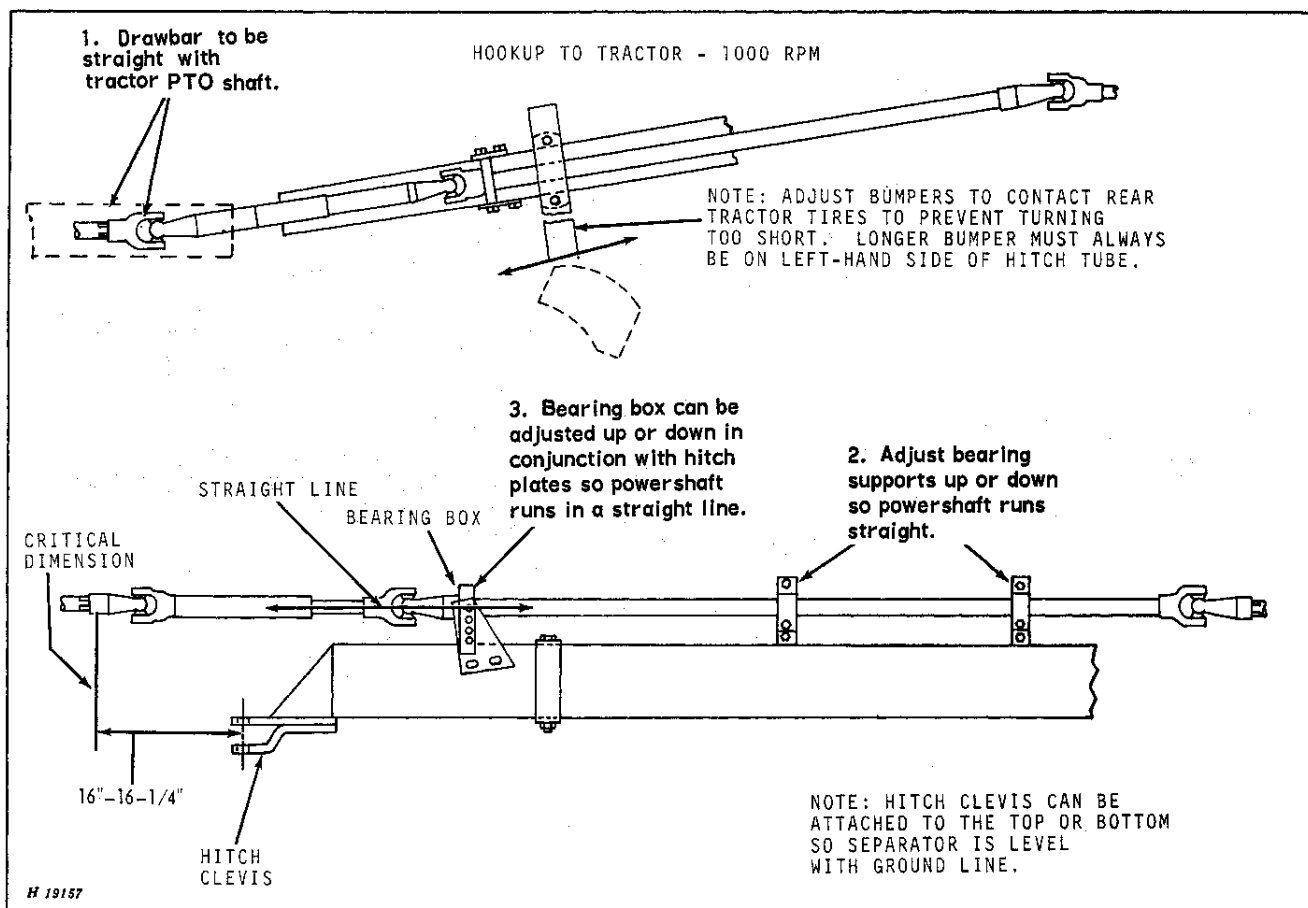

COMBINE BREAK-IN

Follow the lubrication instructions and periodic service information closely (page 27).

STARTING THE COMBINE

CAUTION: Make certain no one is standing near enough to the combine or tractor to touch any moving parts. Warn everyone to stand clear.

When tractor is properly warmed, idle engine and engage PTO slowly to engage the separator. Then run tractor at rated PTO speed.

Check the speed of the primary countershaft with a speed indicator (page 45). The countershaft should operate at 1500 rpm with separator empty and not under load. If the countershaft speed is incorrect, check tractor PTO speed. If PTO is not operating at proper rpm rated speed, see your John Deere dealer.

TRANSPORTING

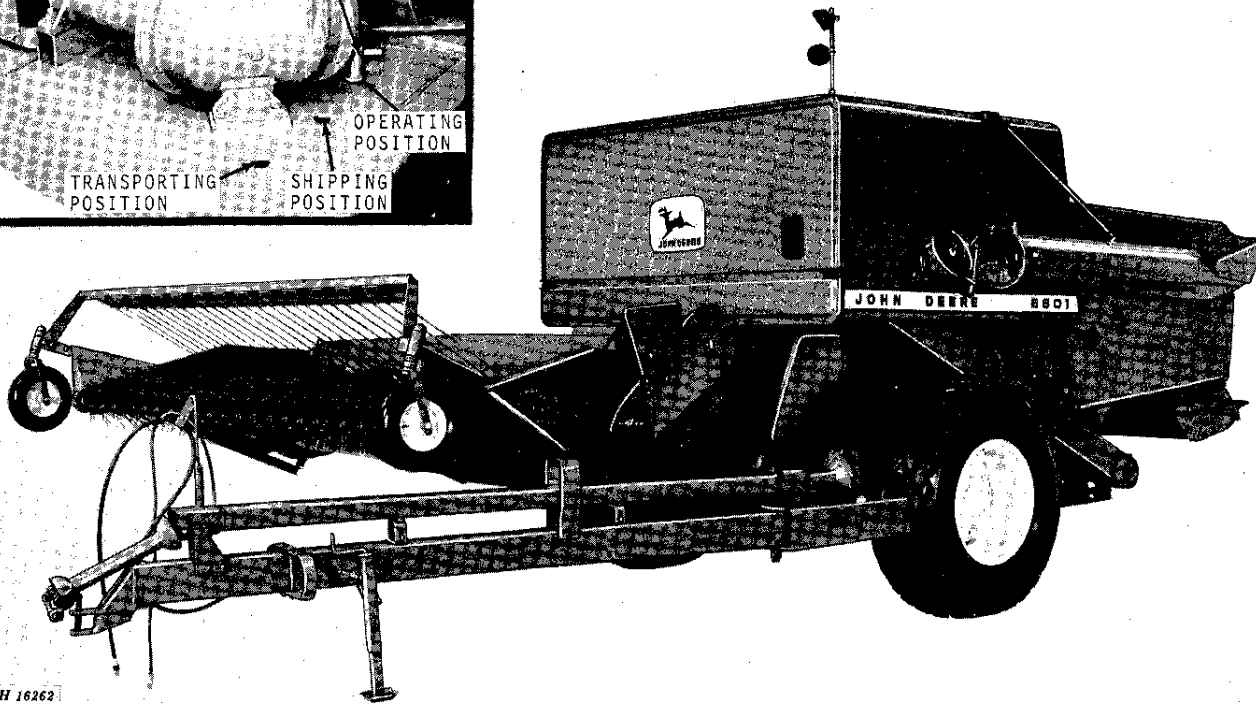
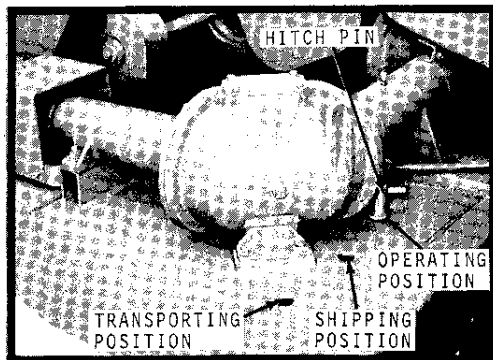

Combine in Transport Position

This combine is designed for easy and safe transporting. The width of the combine can be reduced by: folding unloading auger back along separator, removing the platform, and moving the hitch.

To fold unloading auger back along separator, unfasten over-center lock and swing outer auger back. Secure outer end of auger against separator with transport lock (page 53).

IMPORTANT: Always fold unloading auger back along separator and disconnect powershaft when transporting the combine.

Three locking positions are provided for the swinging hitch. The inside locking position is for field operation. The center locking position is for loading and transporting the combine on a flat car. Under no circumstances will you need to use this center position once the combine has been removed from the flat car.

The outer position locks the hitch for highway or field transporting. To secure hitch tube in transporting position, raise platform to its highest position. Remove hitch pin from operating position and swing hitch tube inward as far as possible. Install hitch pin in transporting position.

CAUTION: Always use the hydraulic cylinder safety stop (page 12) when transporting the combine with the platform in raised position.

The combine is equipped with a slow moving vehicle emblem on the rear hood, lights, grain tank reflectors, and red reflective tape on the backside of the platform for transporting protection. Keep the emblem, reflectors, and lights clean.

CAUTION: When transporting the combine on a road or highway at night or during the day, use the lights and devices provided on the combine for adequate warning to the operators of other vehicles. In this regard, check your local governmental regulations.

FIELD AND CROP OPERATING ADJUSTMENTS

This section explains all field and crop operating adjustments. Adjustments which are required to compensate for wear and misalignment are explained in the SERVICE section, page 32. For illustrations of controls not shown in this section, see the CONTROLS AND INSTRUMENTS section, page 2.

PLATFORM

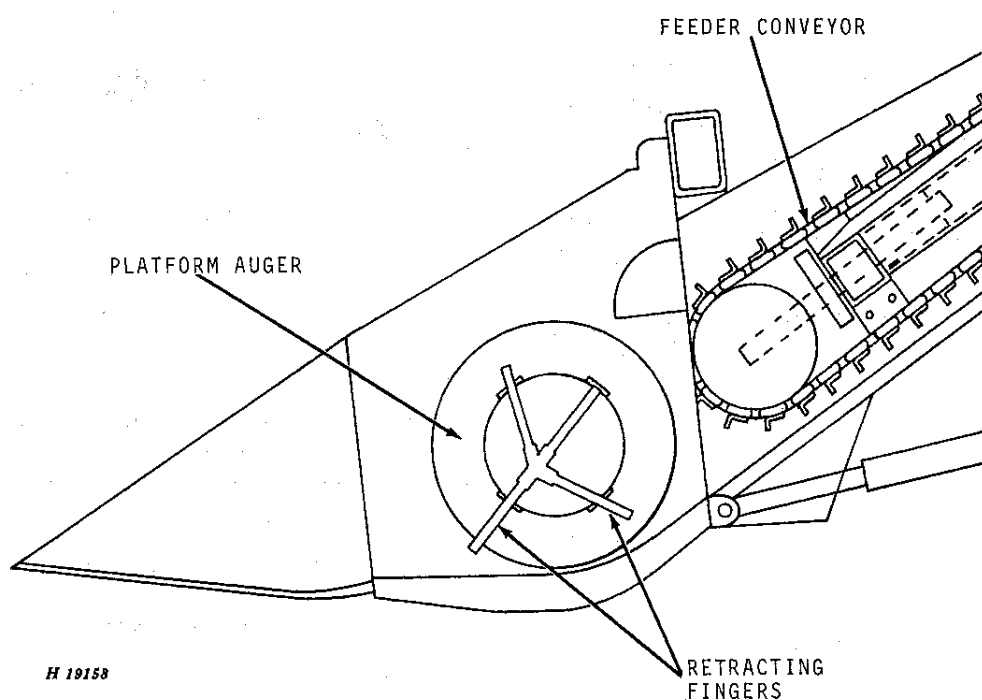

The platform receives the crop and moves it to the front of the feeder house by means of an auger. Retracting fingers on the auger feed the material to the feeder conveyor.

The operation and height of the platform is controlled by the operator from the tractor seat. By operating the platform switch, an electric clutch is either engaged or disengaged, allowing the platform to be started or stopped immediately. When the switch activates the electric clutch, a warning light on the switch box glows red.

The height of the platform is controlled by the tractor remote cylinder operating lever.

Platform performance depends largely on maintaining correct unit speeds (page 23) and keeping the platform as level as possible (page 33).

While servicing the platform, always use the hydraulic cylinder safety stop (page 12).

Platform Switch

Push switch (page 2) down to disengage clutch. Push switch down again to engage clutch.

Platform Switch Warning Light

The warning light (page 2) glows red when the platform switch is activated.

Platform Height Control

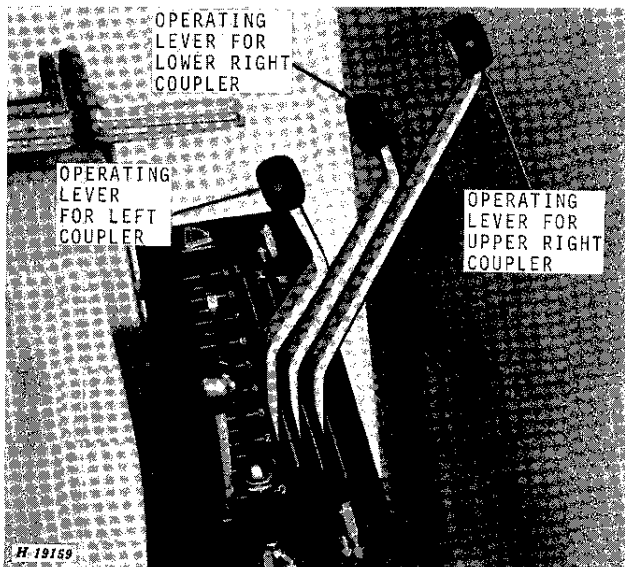

Remote Cylinder Operating Levers on 4020 Tractor

Raise and lower the platform with the remote cylinder operating lever on the tractor. To raise the platform, push the lever forward. To lower the platform, pull the lever rearward.

Hydraulic Cylinder Safety Stop

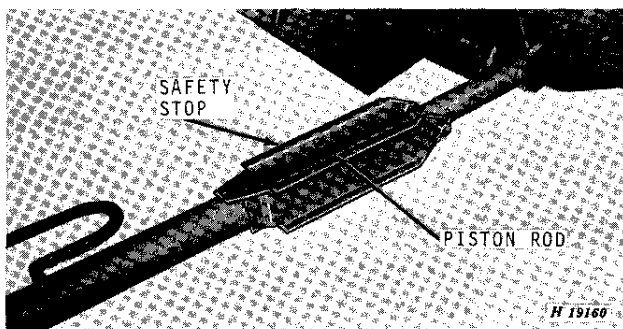

Safety Position

CAUTION: Always use the safety stop when working on the platform or when transporting the combine in the field or on the highway.

To place the stop in safety position, first extend hydraulic cylinder. Disconnect the support chain from the safety stop and position the safety stop on the piston rod.

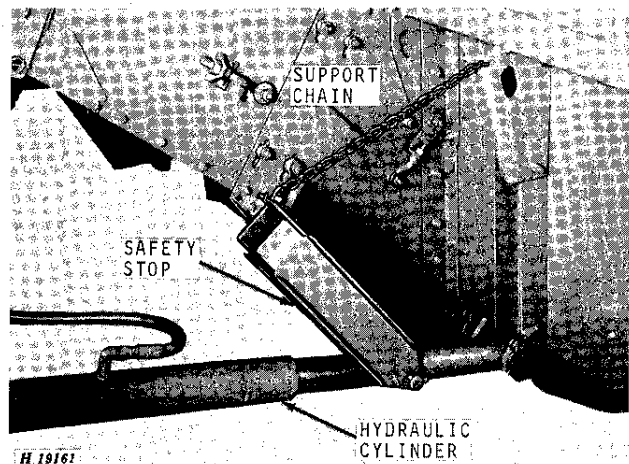

Storage Position

After transporting or completing work on the platform, attach safety stop to support chain for storage.

Platform Auger

The platform auger is set at the factory with 1/8- to 5/8-inch clearance between the auger flights and platform bottom. This setting is required for most crops and conditions.

If the auger is too high or does not have the same relationship at both ends, material may not be fed properly to the feeder conveyor.

It may be necessary to raise the auger when combining coarse stemmed crops or heavy windrows.

When repositioning the auger, maintain the same measurement between the outer ends of the auger and the platform bottom.

Retracting fingers in the auger are adjustable to obtain the best delivery to the feeder conveyor.

Adjusting Auger Height

On right-hand side of platform, loosen two nuts "A." To raise the auger, loosen nut "B" and tighten nut "C." To lower the auger, loosen nut "C" and tighten nut "B."

On the left-hand side, loosen nuts "A" and nut "B." To raise the auger, tighten bolt "C." To lower the auger, loosen bolt "C." Tighten nut "B" and nuts "A."

IMPORTANT: Keep auger level; be certain there is ample clearance for the auger fingers and proper clearance between auger flights and stripper. Check drive chain tension (page 35).

Adjusting Auger Forward or Rearward

On right-hand side of platform, loosen the two bolts "D" in the adjusting bracket. Move auger to the necessary position, and tighten nuts.

NOTE: Do not disturb finger height setting.

On left-hand side, loosen nut "D" and tighten nut "E" to move the auger rearward. Loosen nut "E" and tighten nut "D" to move the auger forward.

Adjusting Finger Clearance

Maintain equal clearance between both the end finger bearings and the finger cranks, as illustrated. Loosen lock nut "F" on right-hand side of platform and move shaft in or out as necessary. Then secure shaft in position by tightening lock nut "F."

Adjusting Finger Height

On the right-hand side of the platform, loosen the two bolts "G" in the adjusting bracket and pivot the top of bracket forward to move the extended fingers down on the auger tube. Minimum clearance between fingers and platform bottom is 1/8 to 1/4 inch. Tighten nuts. To move fingers up, reverse the procedure.

NOTE: Do not disturb the auger forward and rearward adjustment.

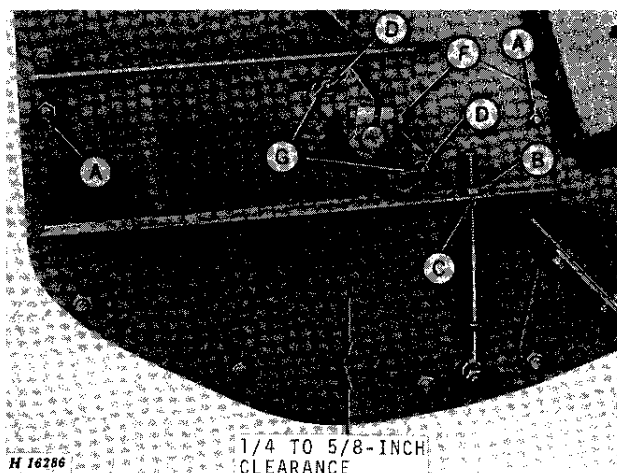

Right-Hand Side

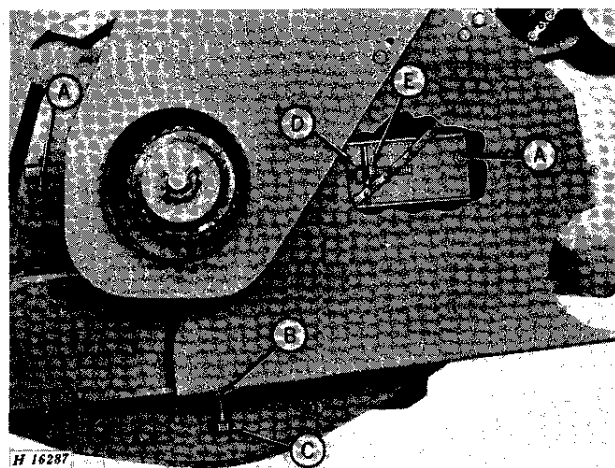

Left-Hand Side

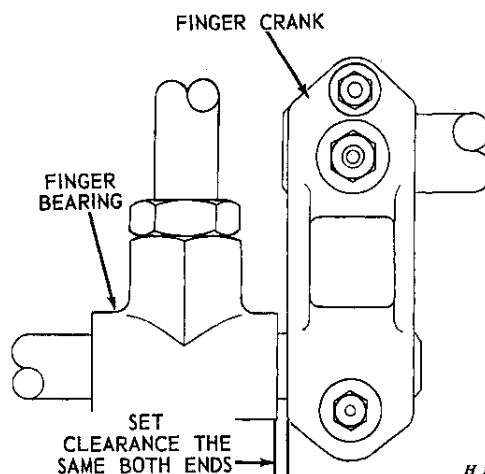

FEEDER HOUSE

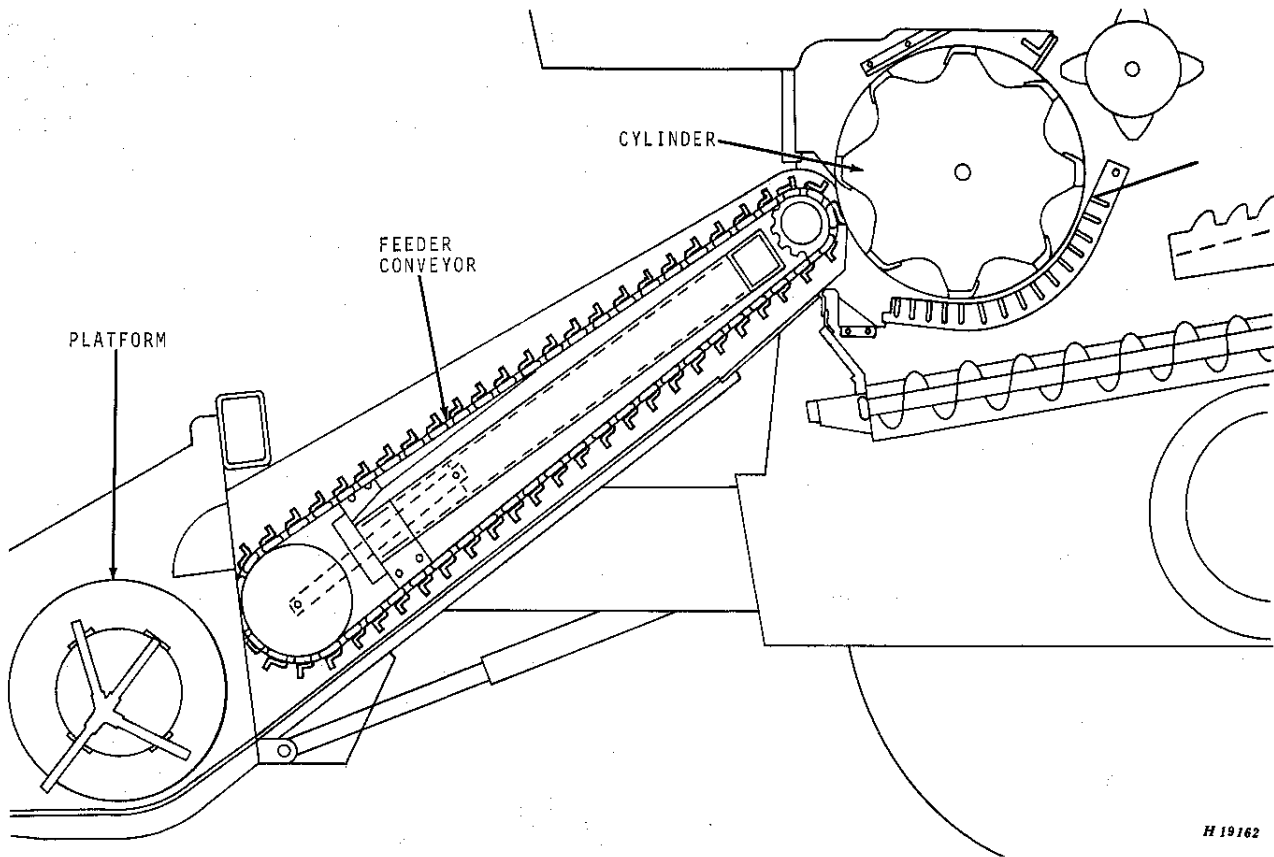

H 19162

Conveyor Chain

Adjust the chain until the slats begin to rise off the rear of the feeder house bottom at the row of counter-sunk bolts (page 35). Too much slack allows the chain links to jump the sprocket teeth.

Do not overtighten the chain.

Conveyor Chain Float

Floating action of the conveyor accommodates varying volumes of material. Adjust the conveyor "float" so a 1/8-inch space exists between a slat and the feeder house bottom directly under the feeder drum (page 36).

SEPARATOR

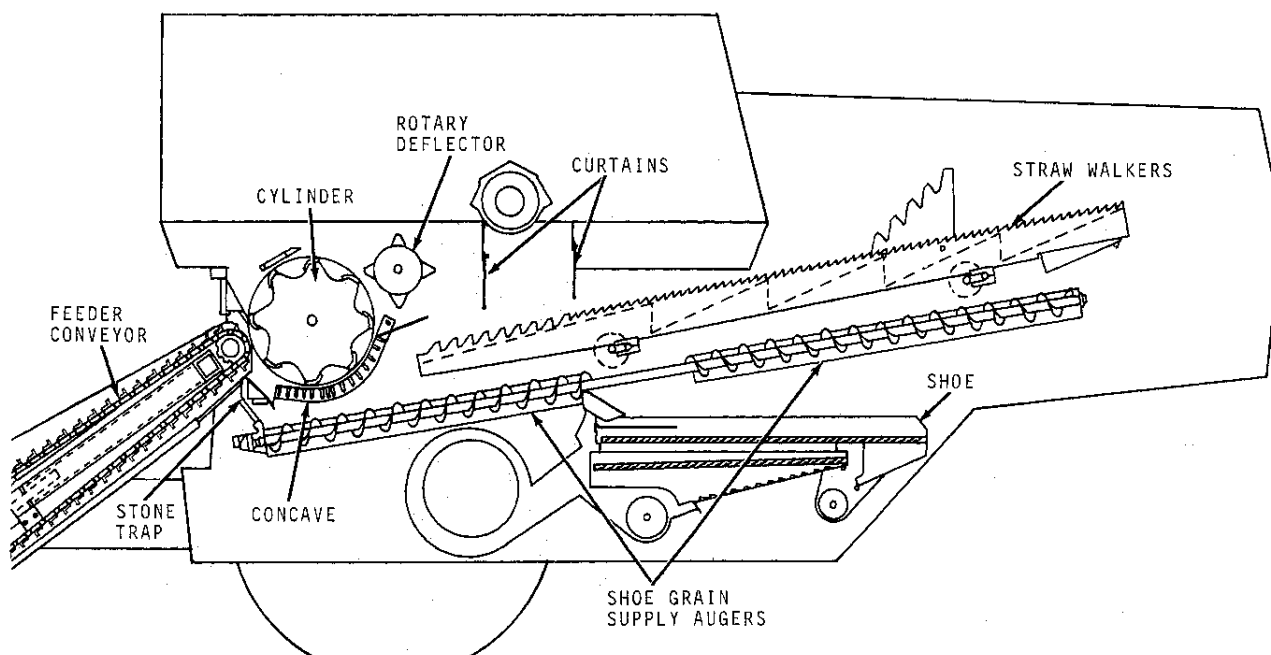

H 19163

The separator receives the force-fed material from the feeder conveyor and separates up to 90 percent of the grain from the straw at the cylinder and concave. This free grain falls immediately through the concave grate into the shoe grain supply augers.

The remaining straw and grain pass under the rotary deflector and curtains which regulate the flow of straw onto the straw walkers. The walkers lift and tumble the straw permitting the remaining grain to fall through the walkers into the shoe grain supply augers. The straw is carried over the walkers and out of the combine.

The shoe grain supply augers are positioned under the cylinder and concave and extend to the rear of the straw walkers. The front half of each auger conveys grain from the cylinder and concave rearward to the front of the shoe. Flights on the rear half of each auger are reversed to convey grain that falls through the straw walkers forward to the front of the shoe.

Regardless of the crop harvested, good separation is directly dependent on the speed of the separator. The separator speed is determined by the speed of the primary countershaft. Keep primary countershaft speed at 1500 rpm at all times (page 45).

Reducing the primary countershaft speed reduces the speed of the platform, straw walkers, cleaning shoe, elevators, and augers. This sluggishness can result in clogging and grain loss.

Increasing the primary countershaft speed causes material to pass through the combine too rapidly, causing grain loss and strain and wear on all moving parts.

The separator is engaged or disengaged by moving the PTO clutch lever on the tractor.

CAUTION: Do not engage separator until everyone is standing away from moving parts or belts.

PTO Clutch Lever

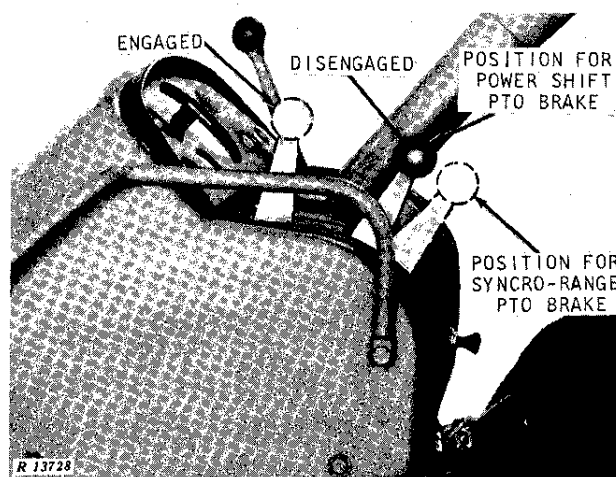

4020 Tractor PTO Lever

To engage the separator, idle tractor engine and push lever forward slowly. After the separator is engaged, run tractor engine at rated PTO speed.

To disengage the separator, idle tractor engine and pull lever rearward.



Suggest:

If the above button click is invalid.

Please download this document

first, and then click the above link

to download the complete manual.

Thank you so much for reading

Cylinder

Good threshing depends on proper relationship between the cylinder speed and the cylinder-concave spacing. A large seed requires low speed and a wide spacing to prevent cracking; a small seed requires high speed and a close spacing so the seed will be rubbed out.

Between these two extremes are the many crops a combine is expected to handle. Carefully select the best relationship for each crop (page 24). Neglect or carelessness can mean heavy crop losses.

This combine is equipped with a variable speed cylinder with a speed range from 407 rpm to 1229 rpm. A special drive sheave may be purchased from your John Deere dealer to provide a slower speed range (280 rpm to 845 rpm) for combining large seed (page 43).

Change the cylinder speed by turning a control crank on the clean grain elevator. Check the tension on the control chain periodically (page 40).

Cylinder Speed Control Crank

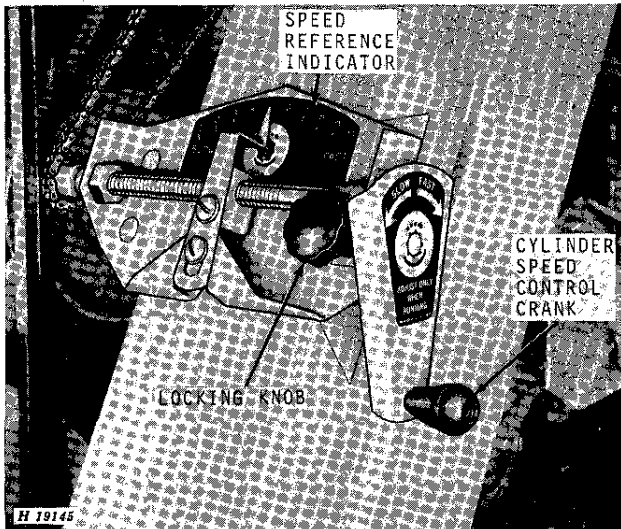

Loosen locking knob.

To increase the cylinder speed, turn the crank toward "FAST."

To decrease the cylinder speed, turn the crank toward "SLOW."

Tighten locking knob.

IMPORTANT: Adjust the cylinder speed only when the separator is running.

A cylinder speed reference indicator is mounted on the back side of the clean grain elevator. The reference numbers are a guide to the operator so he can return to the cylinder speed setting that was previously found best for a particular crop or field condition.

See Suggested Settings Chart, page 24.

Choked Cylinder

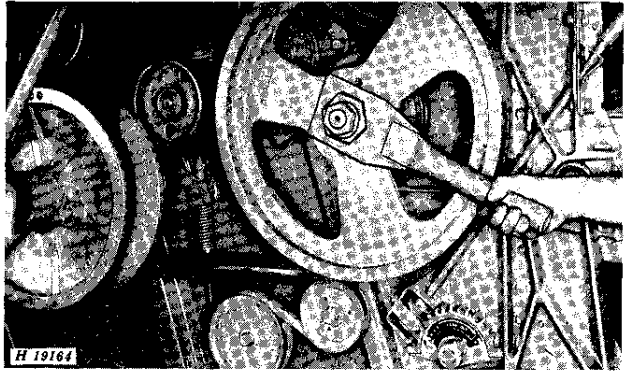

If the cylinder becomes choked, open concave and run separator to clean cylinder.

CAUTION: If cylinder remains choked, shut off tractor.

Leave concave fully open and remove all straw and other material from front of concave through the cylinder front door. Place the cylinder rocker on the nut on the right-hand end of the cylinder shaft. Rock the cylinder back and forth until the cylinder is clear.

Be certain to adjust the concave to original position after the cylinder has been cleared.

Concave

The concave may be adjusted from almost no spacing to a front spacing of 1-1/2 inches measured at the fourth grate bar. It is designed so the rear spacing automatically increases or decreases to half the front spacing. Thus, the rear of the concave never needs adjusting unless the concave is replaced or the rear spacing is disturbed (page 44). Adjust the concave with the ratchet on the front right-hand side of the separator.

<https://www.ebooklibonline.com>

Hello dear friend!

Thank you very much for reading.

Enter the link into your browser.

The full manual is available for immediate download.

<https://www.ebooklibonline.com>