

# 6600 AND 7700 COMBINES



JOHN DEERE

## OPERATORS MANUAL 6600 AND 7700 COMBINES

OMH88381 J4 English

JOHN DEERE HARVESTER WORKS  
OMH88381 J4

LITHO IN THE U.S.A.  
ENGLISH





## To the Purchaser

---

This new combine was carefully designed and manufactured to give years of dependable service. To keep it running efficiently, read the instructions in this operator's manual. Each section is clearly identified so you can easily find the information you need—whether it is operation, lubrication, or service. Read the Table of Contents to learn where each section is located. Use the alphabetical index for fast reference.

 This safety alert symbol identifies important safety messages in this manual. When you see this symbol, be alert to the possibility of personal injury and carefully read the message that follows.

Your Operator's manual contains SI Metric equivalents which follow immediately after the U.S. customary units of measure.

This operator's manual covers the feeder house and separator areas of the combine. For platform and corn head information, see the separate operator's manuals furnished with that equipment.

In addition to the equipment furnished with your combine, attachments are available to help you do a better job in special crop conditions. These are described in the attachments section of this manual and can be purchased from your John Deere dealer.

"Right-hand" and "left-hand" sides are determined by facing in the direction the combine will travel when in use. The radiator end of the engine is referred to as the "front," the flywheel end as the "rear."

Record your combine serial numbers in the space provided on page 188. Your dealer needs this information to give you prompt, efficient service when you order parts or attachments. If your combine requires replacement parts, go to your John Deere dealer where you can obtain Genuine John Deere parts—accept no substitutes.

The warranty on this combine appears on your copy of the purchase order which you should have received from your dealer when you purchased the combine.





# Contents

	Page
Safety suggestions .....	2, 3
Controls and instruments .....	4-6
Operation .....	7-52
Fuels and lubricants .....	53-54
Lubrication and periodic service .....	55-69
Service .....	70-157
Trouble shooting .....	158-176
Storage .....	177-180
Attachments .....	181-185
Specifications .....	186-192
Index .....	193-196

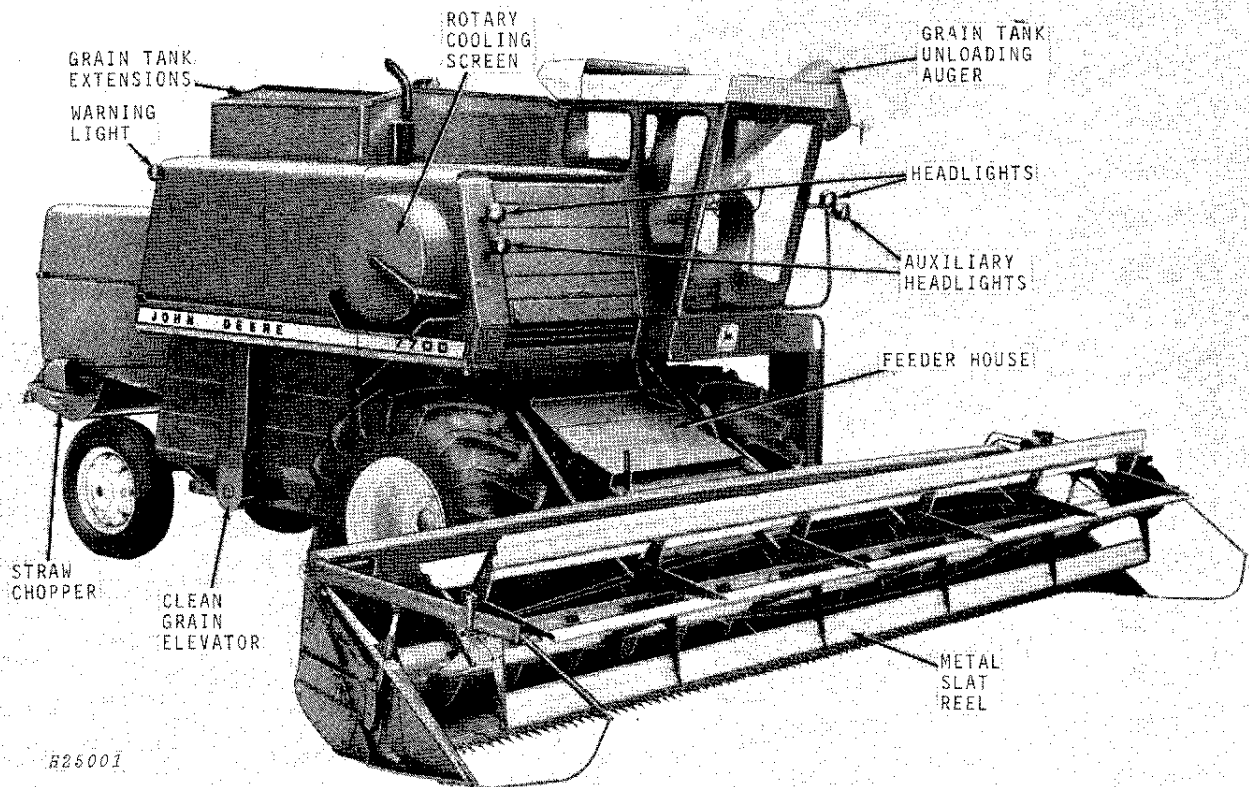

H25001

John Deere 7700 Combine

**<https://www.ebooklibonline.com>**

Hello dear friend!

Thank you very much for reading.

Enter the link into your browser.

The full manual is available for immediate download.

**<https://www.ebooklibonline.com>**



# Safety Suggestions

---

**⚠** The safety of the operator was one of the prime considerations in the minds of John Deere engineers when this combine was designed. Shielding, simple adjustments, and other safety features were built into the combine wherever possible.

All machinery should be operated only by responsible persons who have been properly instructed and delegated to do so.

Only the operator should be allowed on the operator's platform when the combine is in operation.

Clothing worn by combine operator should be fairly tight and belted. Loose jackets, shirts, or sleeves should never be worn because of the danger of getting into moving parts.

Be sure shields and guards are in place and in good condition before starting in the field.

Escaping fluid under pressure can have sufficient force to penetrate the skin, causing serious personal injury. Before disconnecting lines be sure to relieve all pressure. Before applying pressure to system, be sure all connections are tight and that lines, pipes and hoses are not damaged. Fluid escaping from a very small hole can be almost invisible. Use a piece of cardboard or wood, rather than hands, to search for suspected leaks.

If injured by escaping fluid, see a doctor at once. Serious infection or reaction can develop if proper medical treatment is not administered immediately.

Before applying cylinder breaker bar, always disengage separator and shut off combine engine. After clearing cylinder, remove cylinder breaker bar before restarting engine and engaging separator.

Use the hand rail when mounting the combine.

Make sure everyone is clear of the combine before starting so they cannot be struck by moving parts or caught in a drive belt or chain.

Never clean, lubricate, or adjust the combine when it is running.

Be especially careful when operating on hillsides because the combine may tip sideways if it strikes a hole, ditch, or other irregularity.

Always keep the combine in gear when going down hills.

Lower safety stop when working on platform or corn head.

Before leaving the combine unattended, support the cutting platform or corn head with either the hydraulic cylinder safety stop or with blocks, or lower it to ground level.

Never attempt to clear obstructions off the platform or corn head unless the combine is stopped and the engine shut off.

Keep the operator's platform clean. Do not use it as a place to carry loose tools, lunch boxes, etc.

Keep the engine clean of chaff and straw to prevent the possibility of fires.

Refuel your combine only when the engine has been shut off. Do not smoke or have an open flame when refueling.

Maintain a fire extinguisher in an easily accessible location and be familiar with its' correct use.

Refill the radiator only when the engine is stopped or idling slowly. This combine has a pressure cooling system. To avoid being scalded when radiator cap is removed, first turn cap slightly to the stop which allows steam to escape through the overflow pipe. After all pressure is relieved, remove cap.

Be sure the gearshift lever of your combine (or speed range lever on hydrostatic drive combine) is in neutral and clutch pedal fully depressed before starting the engine.

Adjust combine brakes so pressure is equally applied. Reduce variable ground speed before applying brakes. Apply brakes evenly at transport speeds to avoid drawing combine to one side. Quick stops can result in combine nosing forward. Drive with care to allow controlled application of brakes at all times.

Before using booster battery, read instructions under "Cold Weather Battery Service."

When transporting the combine on a road or highway at night or during the day, use accessory lights and devices provided for adequate warning to the operators of other vehicles. In this regard, check your local governmental regulations.

Fold the unloading auger when transporting.

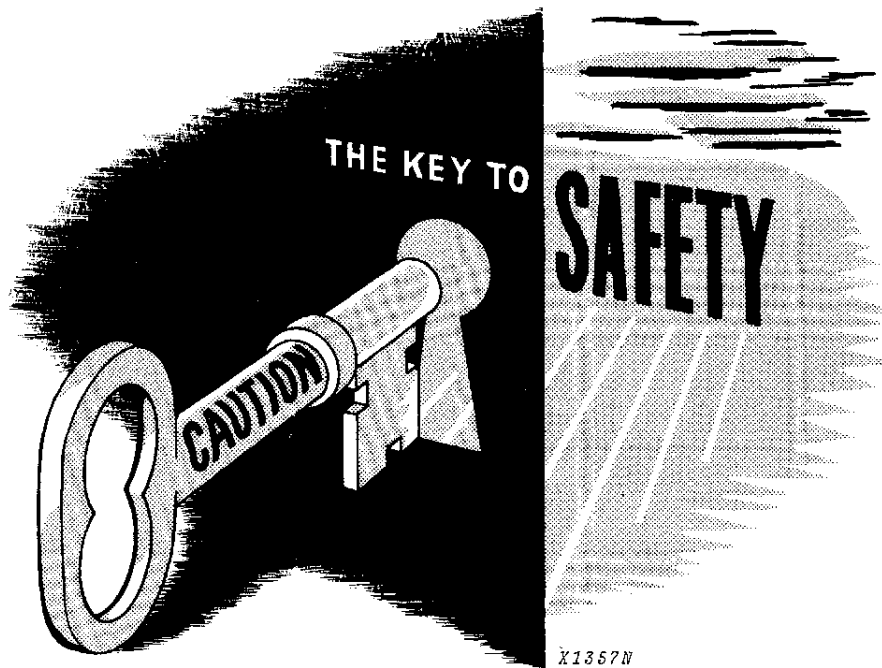



# Controls and Instruments

Before attempting to operate your new combine, become familiar with the location and purpose of its controls and instruments. Study these pages carefully, regardless of your previous combine experience.

The control levers and knobs have different colors and shapes to help you quickly locate the controls while operating the combine. Colors on controls indicate:

**RED**—Combine movement controls (Throttle, Gearshift Lever, Selective Ground Speed Control)

**YELLOW**—Auxiliary Power Controls (Separator Control Lever, Cylinder Speed Control Ratchet, Platform or Corn Head Electromagnetic Clutch Switch)

**BLACK**—Miscellaneous Function Controls (Platform or Corn Head Height Control, Hydraulic Lift Reel Control, etc.)

## OPERATOR'S PLATFORM

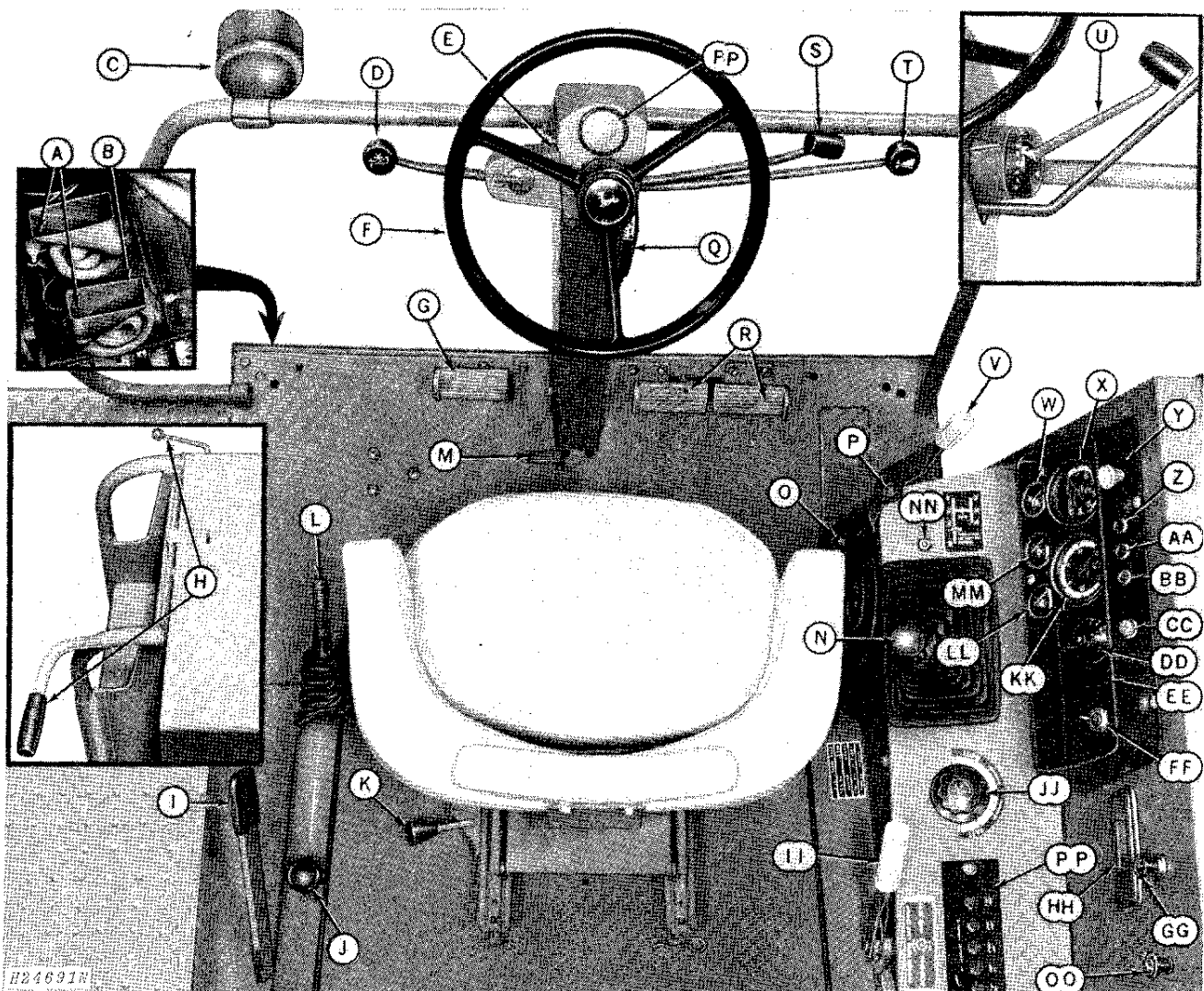

**ENGINE - AIR INTAKE**

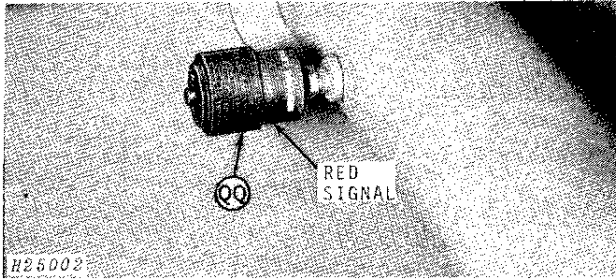

**SEPARATOR**

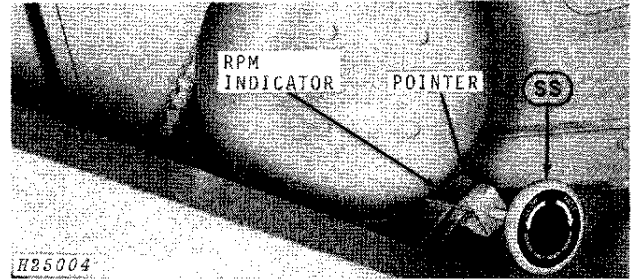

**FEEDER HOUSE**

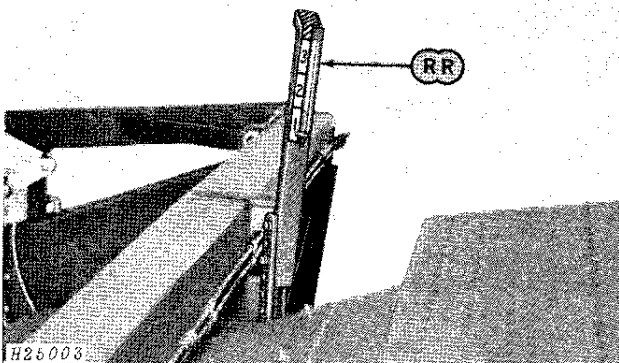

	Page
A - Truck Signal Horns .....	41
B - Coolant Temperature Warning Horn or Straw Walker Warning Horn (Attachment) .....	12, 41
C - Headlight .....	41
D - Hydraulic Lift Reel Control or Variable Speed Feeder House Control (Optional) .....	22
E - Turn Signals (Attachment) .....	183
F - Steering Wheel .....	38
G - Clutch Pedal (Belt Drive Combine) .....	39
H - Pivoting Ladder .....	16
I - Grain Tank Unloading Auger Lever .....	36
J - Unloading Auger Hydraulic Swing Control .....	36
K - Operator's Seat Control .....	15
L - Parking Brake Lever .....	38
M - Steering Column Control .....	16
N - Gearshift Lever .....	37
O - Concave Opening Control Wheel .....	28
P - Throttle .....	11
Q - Ground Speed Indicator (Regular on 7700; Attachment on 6600) (Belt Drive Combine) .....	37
R - Brake Pedals .....	39
S - Selective Ground Speed Control .....	37
T - Platform or Corn Head Height Control .....	21
U - Hydrostatic Drive Speed Range Control .....	38

	Page
V - Separator Control Lever .....	27
W - Fuel Gauge .....	12
X - Engine Tach-Hour Meter .....	12
Y - Platform or Corn Head Electromagnetic Clutch Switch (Optional) .....	22
Z - Parking Brake Indicator Light .....	38
AA - Alternator Indicator Light .....	12
BB - Transmission Oil Pressure Indicator Light .....	38
CC - Cold Weather Starting Aid Button .....	41
DD - Light Switch .....	41
EE - Horn Button .....	41
FF - Key Switch .....	11
GG - Cigarette Lighter .....	41
HH - Ash Tray .....	41
II - Cylinder Speed Control Ratchet .....	27
JJ - Hydrostatic Drive Reel or Hydrostatic Drive Belt Pickup Control .....	22
KK - Cylinder Speed Tachometer .....	27
LL - Coolant Temperature Gauge .....	12
MM - Engine Oil Pressure Gauge .....	12
NN - Powered Rear Wheel Drive Switch (Optional 7700 only) .....	00
OO - Engine Fuel Shut-Off 404 (Diesel Engine only) .....	11
PP - Low Shaft Speed Monitor .....	17
QQ - Air Restriction Indicator (Regular on 7700; Attachment on 6600) .....	12
RR - Platform Float Spring Indicator (Attachment) .....	24
SS - Fan Speed Control Wheel .....	34
TT - Chaffer Opening Control .....	34
UU - Sieve Opening Control .....	34

## OPERATOR'S CAB CONTROLS

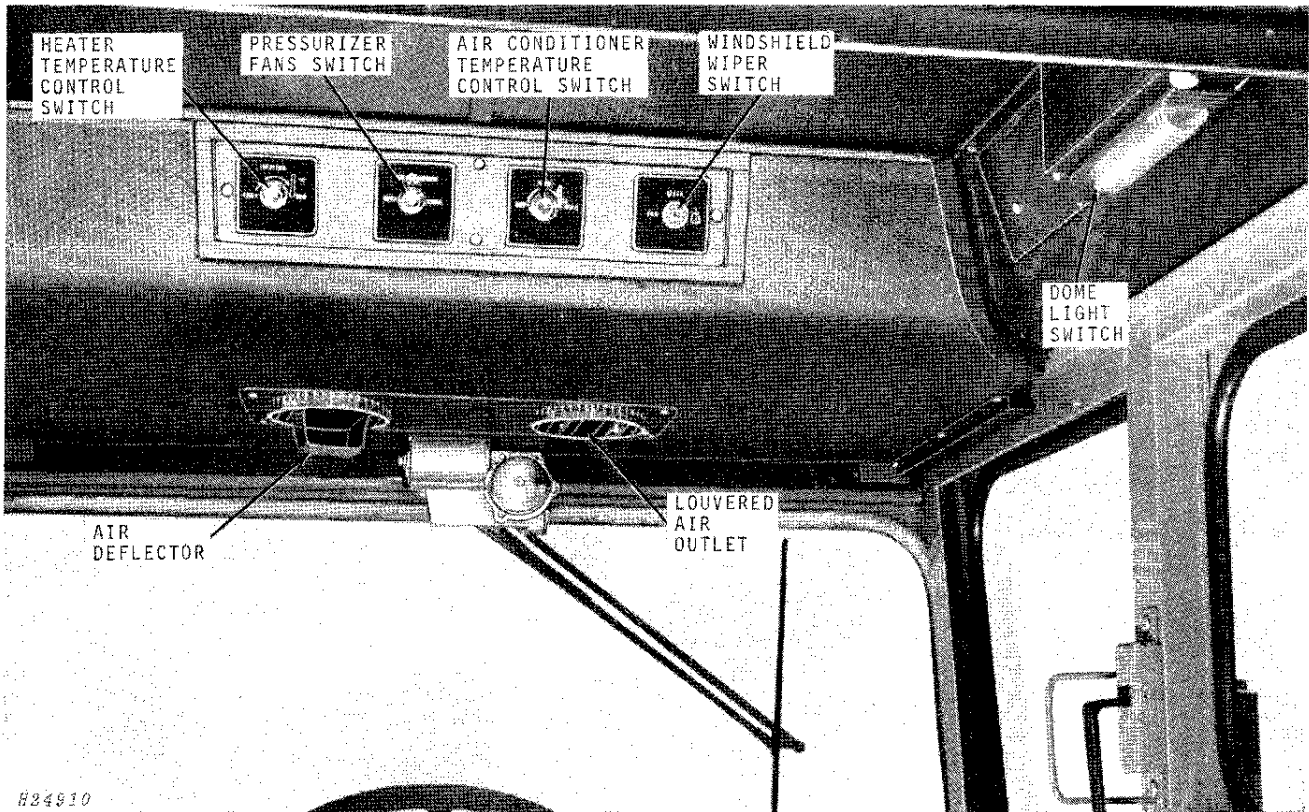

The operator's cab controls are conveniently located in the cab headliner to the front and side of the operator. The radio is located in the rear right-hand corner of the cab.

### Heater Temperature Control Switch

The amount of heat in the cab is controlled by turning the heater control switch clockwise, from the "OFF" position toward the "HOT" position. Turning the switch all the way to the "HOT" position will provide maximum heating.

### Pressurizer Fans Switch

This switch controls the fans which pressurize the cab. This is a three-speed switch with the highest speed obtained by turning the switch clockwise as far as it will go.

**IMPORTANT:** Pressurizer fans must be operating whenever the heater or air conditioner is in use.

### Air Conditioner Temperature Control Switch

The air conditioner temperature control switch is a thermostatic-type switch which will maintain the desired temperature.

Cool air in the cab is controlled by turning the air conditioner temperature control switch from the "OFF" position clockwise toward the "COLD" position. Turning the switch all the way to the "COLD" position will provide maximum cooling.

### Windshield Wiper Switch

This is a two-speed switch. Turning the switch clockwise to the first detent will give normal wiper operation. The second detent position will produce a faster wiper action. When the switch is turned all the way counterclockwise, the wiper will return to its stop position.

### Louvered Air Outlets

The air outlets are adjustable, enabling the operator to control the flow of air into the cab. The outlets can be turned 360 degrees. One of the air outlets is equipped with an air deflector to further control air flow.

### Dome Light Switch

Moving this toggle-type switch to the right turns the dome light on; moving this switch to the left turns the light off.



# Operation

## ENGINE OPERATION AND COMBINE BREAK-IN

### ENGINE OPERATION

The engine is ready for normal operation. However, to facilitate engine break-in, follow these precautions:

1. Refer to Pages 8 and 9 for prestarting and starting instructions.
2. When starting the engine, operate at part throttle at least 5 minutes to warm up engine before engaging separator or transporting. Monitor oil pressure and water temperature and check for oil leaks.
3. Engage the separator and operate at 1500-1800 engine rpm for 5 to 10 minutes. Continue to monitor oil pressure and water temperature.
4. During the first 20 hours of field operation, reduce ground speed to prevent overloading the engine. Avoid excessive engine idling and no load operation during the first 100 hours.
5. If it is necessary to add engine oil during the first 100 hours, see recommendations on Page 54.

### COMBINE BREAK-IN

Follow the lubrication instructions closely. See pages 55 to 69.

Check coolant level in radiator and add coolant if necessary. Do not use water containing alkali. If combine is being operated in temperatures below 40°F., (4°C) refer to "Cold Weather Operation," page 10.

### After 1 Hour

Check torque on drive wheels and steering wheels.

Drive Wheels:

300 ft-lbs (405 Nm) torque.

Steering Wheels:

80 ft-lbs. (110 Nm) torque-6 bolt wheel-6600-7700  
120 ft-lbs (160 Nm) torque-8 bolt wheel - 7700

### After 5 Hours

Check all V-belts for initial stretch. Tighten if necessary. Continue to check V-belts every few hours for the first 50 hours.

### After 20 Hours

Drain oil from main hydraulic unit reservoir. Replace the oil filter and fill the reservoir with correct oil as specified on page 54. Thereafter, drain and replace oil and oil filter element every 500 hours of operation.

### After 100 Hours

After the first 100 hours of operation, drain oil from crankcase, replace oil filter, and fill crankcase to proper level with John Deere Torq-Gard Supreme engine oil or its equivalent as specified in lubricants chart on page 54.

Thereafter change the oil and filter every 100 hours of operation or every season, whichever occurs first.

## ROTARY COOLING SCREEN

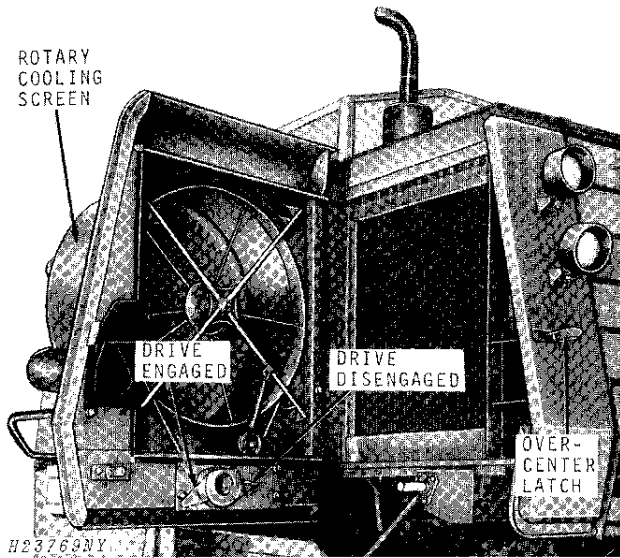

*Screen Door Open for Illustrative Purposes*

**IMPORTANT:** When operating the combine in below freezing temperatures, be certain the rotary screen is free to turn before starting the engine. An accumulation of snow or frozen moisture could prevent the rotary screen from turning, resulting in belt failure.

The rotary screen drive must be engaged whenever the engine is running.

Disengage screen drive by moving lever rearward and up.

Pull out on screen door over-center latch and swing door open.

When closing screen door, swing screen door in and fasten over-center latch.

Engage screen drive by moving lever down and forward.

**IMPORTANT:** Rotary screen drive must be fully disengaged before opening or closing screen door.

### PRESTARTING CHECKS

1. Check engine crankcase oil level (Page 58).
2. Check radiator coolant level (Page 149).
3. Drain sediment from fuel filter(s) (Page 144).
4. Clean air cleaner dust cap and precleaner (Page 152).
5. Check and lubricate combine (Pages 55-69).
6. When starting the engine after the combine has been idle for an extended period, pull the fuel shut-off all the way out, and crank the engine with the starter until the engine oil pressure gauge registers pressure. Do not operate the starter more than 30 seconds at a time. After pressure is indicated, move the throttle to the slow idle position, make sure fuel shut-off is all the way in, and start the engine.

## STARTING DIESEL AND TURBOCHARGED DIESEL ENGINES

1. If the engine has not been operated for a long period of time, or if the fuel tank has run dry, bleed the entire fuel system to remove air bubbles; see page 145.

**IMPORTANT: Never let the fuel tank run dry.**

*NOTE: If the prevailing temperature is 40°F (4°C) or lower, it may be necessary to use the cold weather starting aid to start the engine. (See instructions on Page 10).*

2. Disengage platform or corn head electromagnetic clutch switch, separator control lever, and grain tank unloading auger lever.

3. Place gearshift lever in neutral.

4. Depress clutch pedal fully or place the hydrostatic speed range lever in neutral.

5. Move throttle lever to the slow idle position.

6. Make sure fuel shut-off is pushed all the way in on 404 diesel and turbocharged diesel engines.

 **CAUTION: Before starting the combine engine, be sure there is plenty of ventilation. Never operate the combine in a closed building.**

7. Turn key to the "on" position. Check the operation of the alternator indicator light. It should glow red.

8. Turn key to the "start" position. After engine starts, release key.

**IMPORTANT: When starting the engine, never hold the key in "start" position for more than 30 seconds at a time. If the engine does not start within 30 seconds, allow at least 2 minutes for proper cooling of the starter. Be sure to pause a few seconds after a false start to make certain that the starter has stopped completely before another start is attempted.**

If engine fails to start, see TROUBLE SHOOTING, page 168.

**IMPORTANT: Do NOT tow hydrostatic drive combines to start engine.**

9. Make certain the oil pressure gauge registers pressure and the alternator indicator light goes off. If not, stop engine and determine the cause.

10. Idle the engine for several minutes to warm up engine and to insure turbocharger lubrication before accelerating, applying a load, or transporting.

Should the engine be killed when operating under load, immediately restart the engine to prevent overheating of turbocharger parts, caused when the flow of oil for cooling and lubrication is stopped.

11. For the first 30 minutes, the combine should be operated at 25% slower ground speed. Engine must be operated at full throttle to maintain correct separator speed.

## STOPPING DIESEL AND TURBOCHARGED DIESEL ENGINES

1. Place the hydrostatic speed range lever in neutral.

2. Place the gearshift lever in neutral.

3. Allow the engine to idle a few minutes to cool the engine and turbocharger. (Lubrication and cooling of the turbocharger and some engine parts is provided by the engine lubricating oil. Sudden stopping of a hot engine may allow some parts to overheat and cause possible damage.) Allow the temperature gauge to drop well into the white range on the dial.

4. Move the throttle lever to the rear, pull out the fuel shut-off, and then turn the key to the "off" position.

**IMPORTANT: Push fuel shut-off back in immediately after the engine has completely stopped, to prevent difficult restarting.**

Do not attempt to stop engine by turning off fuel supply at tank. Doing so will cause injection pump to run dry and damage internal parts.

5. If it is necessary to add engine oil, see recommendations on Page 54.

## COLD WEATHER OPERATION

### FUEL SYSTEM

Use winter-grade fuel. Fill the fuel tank at the end of the day's run to prevent moisture from condensing in the fuel tank.

### COOLING SYSTEM

Drain, flush, and fill cooling system with a recognized brand of radiator sealer and antifreeze solution. Use a permanent-type (ethylene glycol) antifreeze solution containing rust inhibitors and without stop-leak additive. This type of antifreeze is resistant to evaporation when heated.

Quarts (litre) of Ethylene Glycol  
Required at Lowest Expected Temperature

	6600	7700
+20°F (-7°C)	5 (4.73 l)	6 (5.68 l)
+10°F (-12°C)	8 (7.57 l)	9 (8.52 l)
0°F (-18°C)	10-1/2 (9.94 l)	12 (11.36 l)
-10°F (-23°C)	12 (11.36 l)	14 (13.25 l)
-20°F (-29°C)	14 (13.25 l)	16 (15.14 l)
-34°F (-37°C)	16 (15.14 l)	18-1/2 (17.51 l)

After filling, check system for leaks.

### BATTERIES

When the temperature drops below freezing, be sure batteries are fully charged. A badly discharged battery freezes more quickly than one that is well charged. For example, a battery with a specific gravity reading of 1.175 (discharged) will freeze at 4°F. (-16°C), and a battery with specific gravity reading 1.300 (fully charged) will not freeze until the temperature reaches -65°F (-54°C).

In freezing weather, do not add water to the batteries unless engine is going to be run. Water will freeze as it will not mix with the electrolyte until the alternator passes a charging current through the batteries.

**IMPORTANT:** If booster batteries are required, see instructions on page 134.

### COLD WEATHER STARTING AID (Attachment)

Diesel engines may be equipped with an ether starting fluid aid which injects atomized ether fluid into the engine air intake system. Normally, ether is used for starting at temperatures below 40°F. (4°C). Pressurized cans of starting fluid are available from your John Deere dealer.

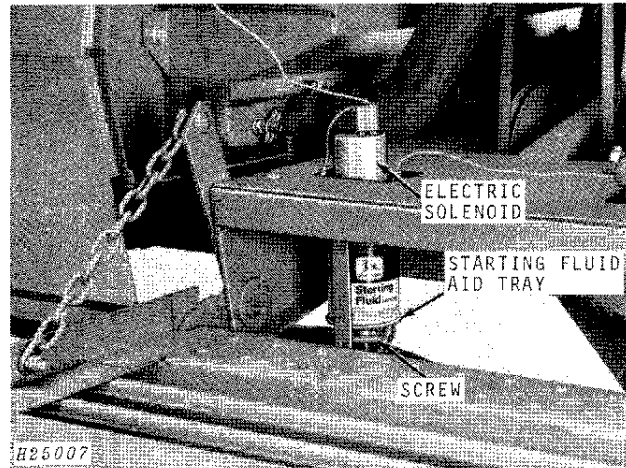

To use the starting fluid aid, remove the safety cap and plastic spray button from can. Loosen screw and place can in starting fluid aid tray. Position can directly under electric solenoid. Tighten screw by hand until nozzle of can is securely seated in the solenoid.

**IMPORTANT:** To avoid damage, turn engine with starter one or two revolutions before injecting starting fluid. Inject starting fluid only while the engine is turning.

To inject starting fluid, press starting aid button (marked "ether") located on instrument panel.

Stop injecting fluid after the engine starts. If the engine begins to die during the first few minutes of operation, inject another "shot" of fluid.

**IMPORTANT:** Fluid can must be left in tray, even if empty, to prevent dirt from being drawn into the engine.

**CAUTION:** Ether starting fluid is highly flammable. Store starting fluid cans where they will not be subject to extreme cold or warm temperatures. For best results, store fluid at room temperature.

## HOT WEATHER OPERATION

The combine has an antifreeze solution in the cooling system and a 7 psi (0.50 bar) pressure valve in the radiator cap. This pressurizes the cooling system so all components must be tight and in good condition for proper operation. Loss of pressure will result in overheating and loss of coolant.

The antifreeze solution should be left in the cooling system during hot weather operation. If coolant is lost or drained out and freezing temperatures are not anticipated, the cooling system can be protected against corrosive action by using summer Engine Coolant Conditioner.

The Summer Engine Coolant Conditioner is available under Part No. T19566, and may be purchased from your John Deere dealer.

To install the Summer Engine Coolant Conditioner, perform the following:

Drain and flush cooling system and add two 32-oz. (0.9463 l) cans of Summer Engine Coolant Conditioner to the cooling system following directions on the container.

**IMPORTANT: Summer Engine Coolant Conditioner is NOT AN ANTIFREEZE or a cooling system sealer. Drain system and fill with recommended antifreeze solution as required for winter protection. When antifreeze solution is in system, it should not be necessary to use the Conditioner; however, should severely corrosive water conditions be present, the Conditioner is compatible with antifreeze solutions.**

## OPERATING THE ENGINE

### ENGINE INSTRUMENTS AND CONTROLS

#### Key Switch

Turn the key to "ON" to check the operation of the alternator indicator light. It should glow red.

Turn the key to "START" and hold until engine starts. Release the key when the engine starts. The alternator indicator light should go out.

If the lights do not go out after 10 seconds, shut off engine at once and determine the cause.

**IMPORTANT: When starting the engine, never hold the key in start position for more than 30 seconds at a time. If the engine does not start within 30 seconds, allow at least 2 minutes for proper cooling of the starter. Be sure to pause a few seconds after a false start to make certain that the starter has stopped completely before another start is attempted.**

If the engine fails to start, refer to the trouble shooting charts on page 168.

If the parking brake is set when the key is turned "ON", the parking brake indicator light will flash off and on. When the parking brake is fully released the light will go out.

#### Throttle

Move throttle lever to the slow idle position when starting engine. Move throttle all the way forward for normal operation; move throttle all the way rearward for slow idle.

#### Fuel Shut-Off (404 Diesel Engines Only)

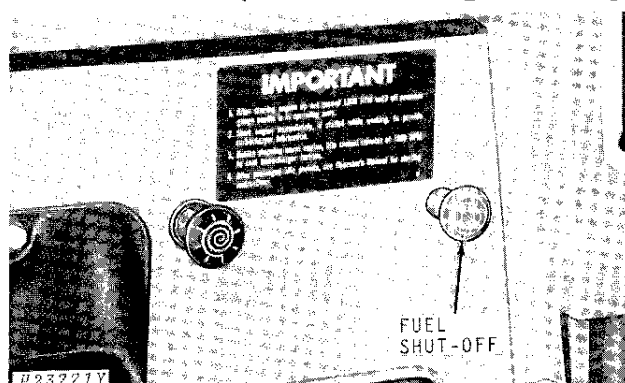

The fuel shut-off knob cuts off the fuel supply to the fuel injection pump. Push the knob all the way in before attempting to start engine.

To stop engine, turn key off and pull fuel shut-off knob all the way out until engine stops running.

**CAUTION:** With key off, engine will continue to run unless fuel shut-off knob is pulled out.

**IMPORTANT:** Push fuel shut-off back in immediately after the engine has completely stopped, to prevent difficult restarting.

### Alternator Indicator Light

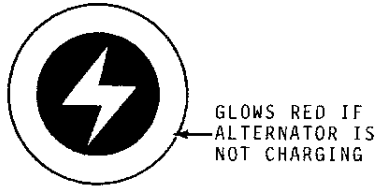

X 2229

This light glows red when the alternator is not charging. If the light goes on while the engine is running, stop engine and determine cause.

Check the operation of this light by turning the key to the "ON" position.

### Coolant Temperature Gauge

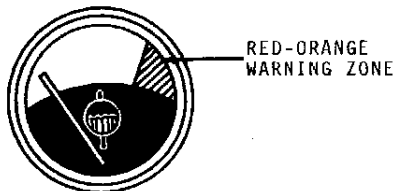

X 2231

This gauge indicates the coolant temperature in the cooling system—not the quantity. The white zone on the dial indicates normal operating temperature; the red-orange zone indicates above normal operating temperature.

If the pointer on the gauge goes into the red-orange zone, stop the engine and determine the cause.

### Coolant Temperature Warning Horn

The low note horn sounds when the coolant temperature gauge registers "HOT." When the straw walker sensing unit (attachment) is activated, the horn will also sound.

If the horn sounds, stop engine and check the straw walkers for plugging and the engine for overheating.

If the straw walkers are not plugged, determine the cause of engine overheating.

### Air Restriction Indicator (Standard - 7700; Attachment - 6600)

The red signal in the restriction indicator is locked in view whenever the air cleaner element is dirty and needs servicing. Check the indicator every 10 hours and service the element (page 153) if necessary.

### Engine Oil Pressure Gauge

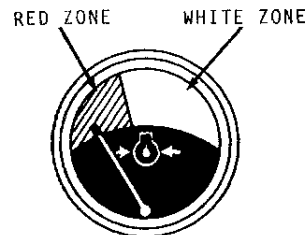

X 2232

This gauge indicates the pressure of the engine lubricating oil—not the amount of oil in the crankcase. Oil pressure will vary slightly with wear, but with recommended oil, it should read NORMAL at full governed speed (indicated by white zone on the dial). If oil pressure drops (indicated by red zone on the dial), stop immediately and determine the cause.

### Fuel Gauge

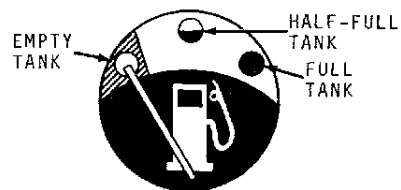

X 2233

The red-orange zone indicates that the tank is empty. A half-full mark and a full mark indicates the fuel level in the tank.

### Engine Tach-Hour Meter

The tach-hour meter shows the engine speed in hundreds of rpm and accumulated engine service in hours and tenths of hours (based on an average engine operating speed of 2500 rpm, 2200 rpm on turbocharged diesel). Use this hour meter to determine when lubrication and periodic services are needed.

## OPERATOR'S PLATFORM COMPONENTS AIR CONDITIONER SYSTEM

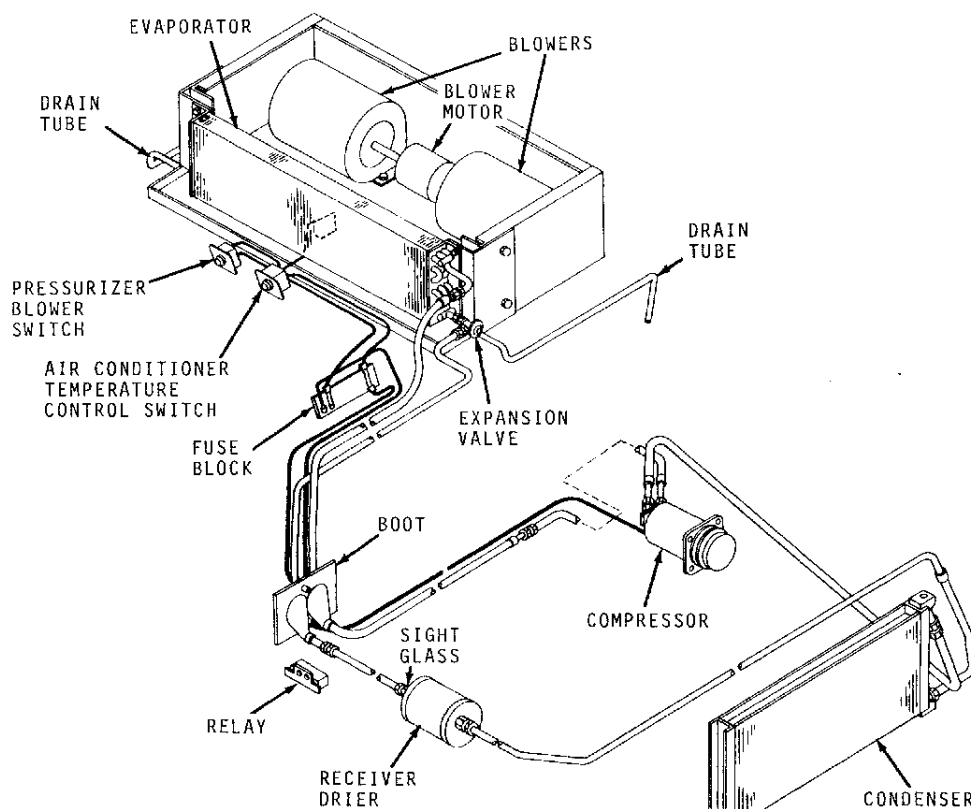

H25009

The air conditioner system consists of a compressor, condenser, receiver-drier, expansion valve, evaporator, hoses and a thermostatic-type control switch.

The air conditioner is operated by a thermostatic-type switch which can be adjusted for a definite cooling range since it is connected to the evaporator.

The refrigerant comes into the compressor as a low-pressure gas, is compressed, and moves out of the compressor as a high-pressure gas. It then flows to the condenser where the gas condenses to a liquid, giving off its heat to the outside air as air, drawn by the engine fan, passes through the condenser. The high-pressure liquid moves to the receiver-drier where a drying agent removes moisture from the liquid. The receiver-drier also stores a quantity of refrigerant to increase capacity of the system.

The high-pressure liquid moves to the expansion valve which restricts liquid flow, thus lowering its pressure. The low-pressure liquid moves to the evaporator where heat from inside the cab moves into the low-pressure liquid, changing the liquid to a low-pressure gas. This low-pressure gas returns to the compressor where the cycle is repeated.

The radiator fan pulls air through the condenser and out the engine compartment. The efficiency of the condenser can be impaired due to dirt or chaff build-up, therefore, it is necessary to keep the condenser and radiator clean.

**IMPORTANT: The pressurizer system must be in operation when the air conditioner is in use.**

The air conditioner requires 56 ounces (1.6 kg) of refrigerant 12 to completely charge the system.

## AIR CONDITIONER SYSTEM—Continued

**⚠ CAUTION:** Air conditioner refrigerant is very dangerous when not handled properly. The air conditioner system should only be serviced by a qualified serviceman.

### Maximum Air Recirculator

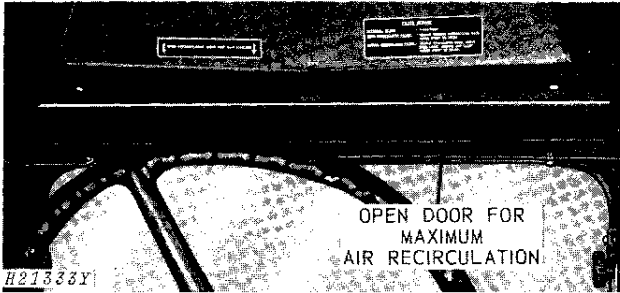

Under normal operating conditions, the normal air recirculator will provide sufficient cooling.

In those conditions which require increased cooling, open the door on the maximum air recirculator at the rear of cab.

## PRESSURIZER SYSTEM

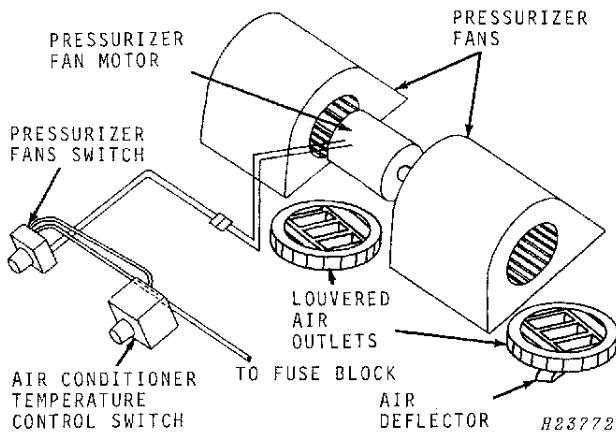

The pressurizer system is made up of two rotating cage-type fans, an electric motor, two louvered air outlets, an air deflector (snapped into one of the air outlets) and a control switch.

The pressurizer fans, when activated by the control switch, increase the pressure inside the cab. With a higher pressure inside the cab, the air and dust will not move from outside the cab to the inside of cab.

The louvered air outlets are also used to direct air flow from the air conditioner and heater.

**IMPORTANT:** The pressurizer system must be in operation when the air conditioner or heater is in use.

## HEATER SYSTEM

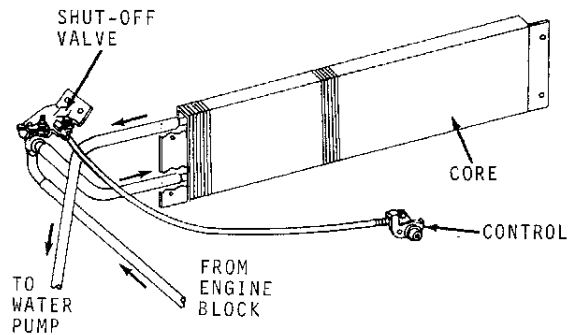

The heater system is composed of a core, a mechanical shut-off valve, hoses, and a control.

With the control knob on, the shut-off valve allows coolant from the engine block to enter, the shut-off valve directs the coolant to the lower tube of the core, and the water moves through the core out the upper tube on the core to the water pump.

The pressurizer fans blow across the heater core as the coolant moves through the heater, removing heat and blowing it through the louvered air outlets into the cab.

**IMPORTANT:** The pressurizer system must be in operation when the heater is in use.

## OPERATOR'S SEAT

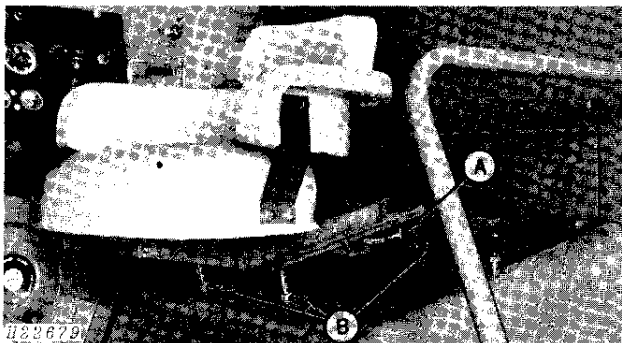

*Seat in Sitting Position*

The operator's seat moves forward and rearward or up and down to accommodate individual height and allow greater accessibility to all controls. If the operator wishes to stand, the seat can be positioned out of the way to allow ample leg space.

Use only warm water and mild soap to clean the seat cushions. NEVER USE SOLVENTS.

### Positioning the Seat Forward or Rearward

While sitting in the seat, push lever "A" forward as far as possible and by using your weight, adjust seat to desired position and then release lever "A."



*Seat in Standing Position*

### Positioning the Seat Up or Down

Remove four spring locking pins "B." Raise or lower the seat to the desired height. Reinsert spring locking pins "B."

### Positioning the Seat for Standing

To move the seat up and back, stand up and apply pressure to the front of the seat with the back of your legs. The seat will move to the up and back position to allow standing room.

To return the seat to the sitting position, move the seat forward by pulling on the front of the seat with your hand.



**Suggest:**

**If the above button click is invalid.**

**Please download this document first, and then click the above link to download the complete manual.**

**Thank you so much for reading**

### STEERING COLUMN

The steering column is adjustable to one of four positions for individual arm lengths. This allows better visibility and greater accessibility to the steering wheel and controls on the steering column.

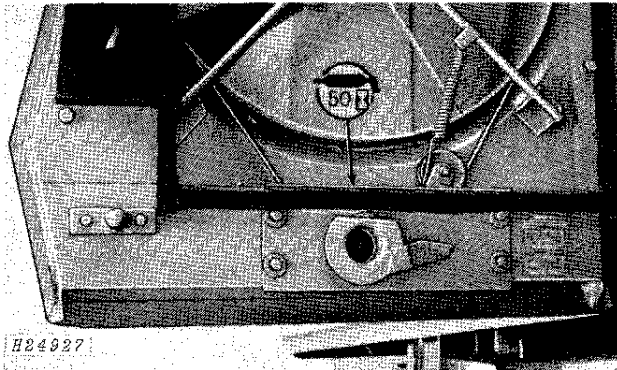

To adjust steering column, push pedal down, position column to desired setting, and release pedal.



### PIVOTING LADDER

Move the pivoting ladder up out of the way of un-cut grain to avoid grain loss by ladder impact.

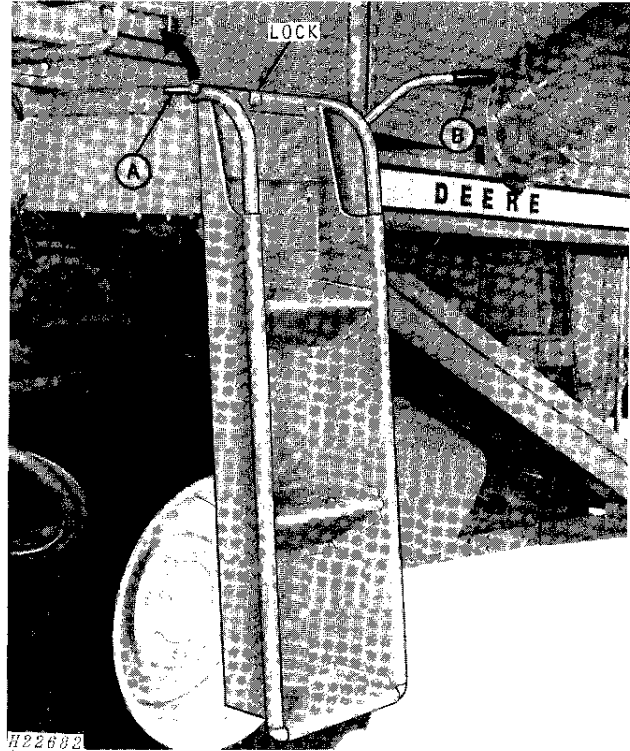

To move ladder, pull lever "A" up and to the right to release the lock.

Pull lever "B" forward until the ladder is parallel to the ground.

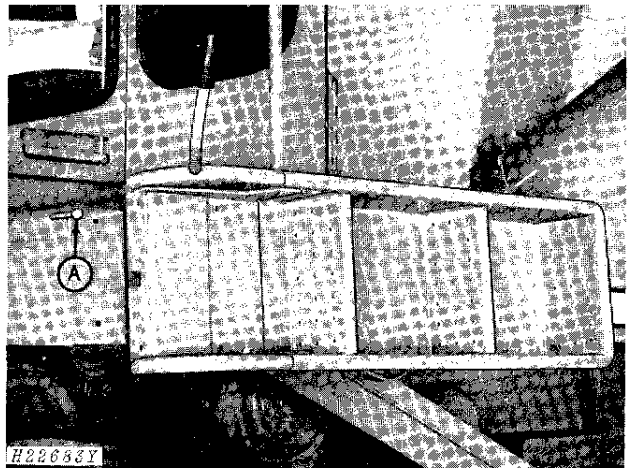

Push lever "A" to the left to lock ladder in place.

To lower the ladder, reverse above procedure.

**<https://www.ebooklibonline.com>**

Hello dear friend!

Thank you very much for reading.

Enter the link into your browser.

The full manual is available for immediate download.

**<https://www.ebooklibonline.com>**