

JOHN DEERE 4520 ROW-CROP TRACTOR



JOHN DEERE

OPERATORS MANUAL JOHN DEERE 4520 ROW-CROP TRACTOR

OMR46011 C9 English

JOHN DEERE TRACTOR WORKS
OMR46011 C9

LITHO IN THE U.S.A. (REVISED)
ENGLISH

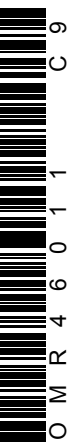

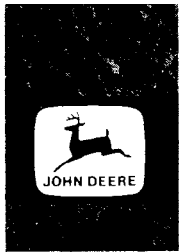

TO THE PURCHASER

Your versatile new John Deere Tractor meets the exacting requirements of modern farming.

Operating ease and comfort, hydraulic power when and where you need it, the ability to match engine power and transmission speed to any job, outstanding economy and dependability, modern styling, and simplicity of lubrication and service are all special features of this great tractor.

We are confident this modern tractor, combined with equally advanced John Deere tools and implements, will help you to farm better, easier, and more profitably.

At the time the tractor was delivered, the John Deere dealer discussed with you its safe operation and proper care. However, before putting the tractor to work, read this manual. It contains complete instructions for operating the tractor, caring for it, and taking full advantage of its many time and labor-saving features. After reading the manual, keep it in a convenient place for quick and easy reference if questions arise concerning operation, lubrication, or service.

The warranty for this tractor appears on your copy of the purchase order which you should have received from your dealer when you purchased the tractor.

Your John Deere dealer wants to help you get the most value from your tractor. His skilled servicemen can handle every job efficiently. These men are trained in modern service methods; they have all necessary tools and equipment. If new parts are needed, only genuine John Deere parts will be installed. These parts are exact duplicates of the originals, made from the same patterns and of the same high-quality materials.

When in need of new parts, be prepared to furnish your dealer with the tractor type, complete tractor chassis serial number, engine type, and complete engine serial number. For ready reference, locate and record the above information in the spaces provided in the illustrations below.

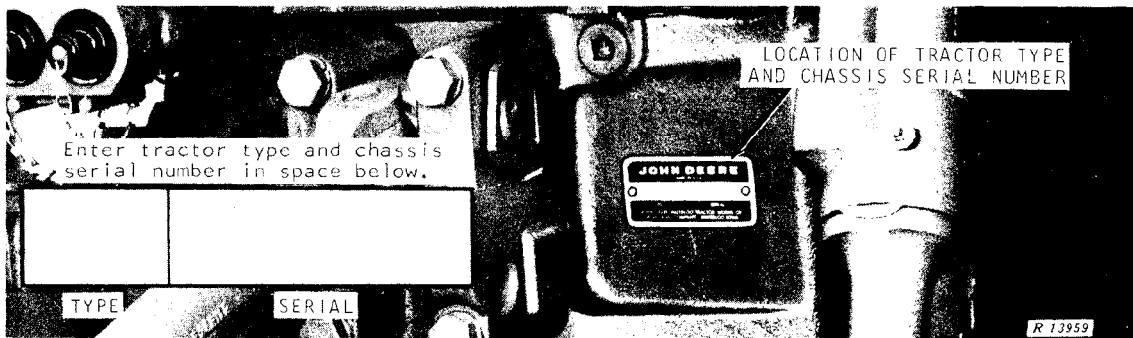

Tractor Type and Tractor Chassis Serial Number

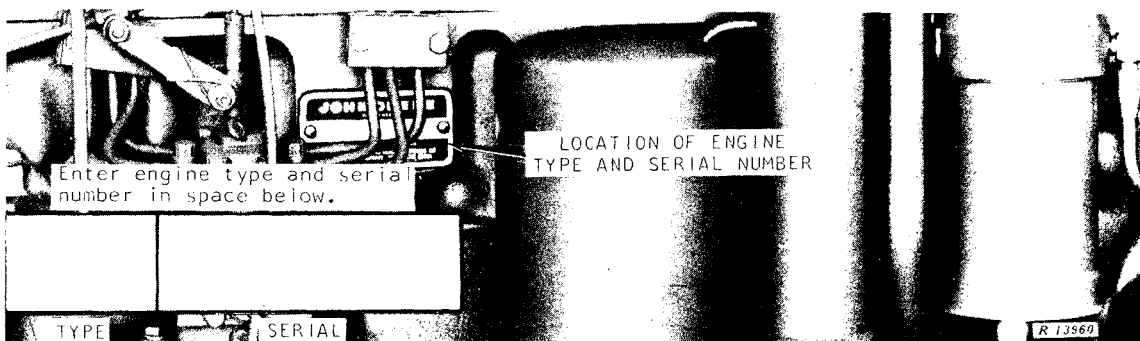

Engine Type and Engine Serial Number



CONTENTS

| | Page |
|--|------|
| SPECIFICATIONS | 2 |
| CONTROLS AND INSTRUMENTS | 4 |
| OPERATION. | 6 |
| SAFETY RULES | 37 |
| FUELS AND LUBRICANTS | 39 |
| LUBRICATION AND PERIODIC SERVICE | 41 |
| SERVICE | 51 |
| TRACTOR STORAGE | 64 |
| TROUBLE SHOOTING | 66 |
| INDEX. | 73 |

<https://www.ebooklibonline.com>

Hello dear friend!

Thank you very much for reading.

Enter the link into your browser.

The full manual is available for immediate download.

<https://www.ebooklibonline.com>



SPECIFICATIONS

HORSEPOWER:*

Observed at PTO (Syncro-Range) . . . 120 hp.

Observed at PTO (Power Shift) . . . 114 hp.

ENGINE:

Type . . . 6-cylinder, in-line, valve-in-head, diesel, turbocharged

Engine Speeds:

Slow idle 800 rpm

Working range 1500 to 2200 rpm

Maximum transport speed . . . 2500 rpm

Bore and stroke 4-1/4 in. x 4-3/4 in.

Displacement 404 cu. in.

Compression ratio 15.7 to 1

Firing order 1-5-3-6-2-4

Valve clearance In.-0.018 in.

Ex.-0.028 in.

Injection pump timing TDC

LUBRICATION SYSTEM: . . Force-feed pressurized with full-flow oil filter

FUEL SYSTEM:

Type Direct injection

Injection pump type Inlet metering, distributing type

Air cleaner Dry type

COOLING SYSTEM:

Type . . . Pressurized with centrifugal pump

Temperature control Heavy-duty thermostat

CAPACITIES:

Fuel tank 50 U.S. gals.

Cooling system 28 U.S. qts.

Crankcase (with filter change) 16 U.S. qts.

Transmission-hydraulic system:

Syncro-Range Transmission 18 U.S. gals.

Power Shift Transmission . 16 U.S. gals.

SYNCRO-RANGE TRANSMISSION:

Type Syncro-Range, constant mesh

Clutch Heavy-duty, 14-3/4 in. plate, foot operated

Gear selections . . . 8 forward and 2 reverse

Shifting 4 stations, synchronized shifting within stations

POWER SHIFT TRANSMISSION:

Type Planetary gears, hydraulically actuated wet disk clutches and brakes

Gear selections . . . 8 forward and 4 reverse

Shifting Hydraulic, powershifting controlled by speed selector

*Above horsepower figures are factory observed at 2200 engine rpm.

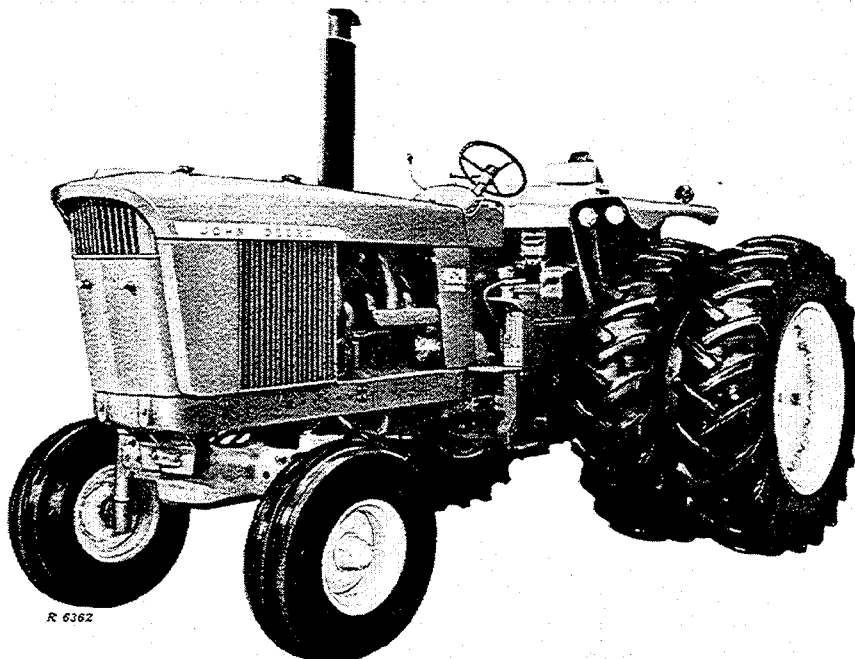

Row-Crop Tractor with Turbocharged Diesel Engine, Syncro-Range Transmission and Double Rear Wheels

POWER TAKE-OFF

Type Independent PTO with mid and rear power take-off controlled by hand-operated clutch lever

Clutch:

Syncro-Range . . . One dry-disk, hydraulically actuated

Power Shift Multiple disk, wet clutch hydraulically actuated

Speed (1900 engine rpm). 1000 rpm

PTO ahead of drawbar hitch point . . . 16 in.

HYDRAULIC SYSTEM:

Type Closed center, constant pressure. Includes power steering, power brakes, implement control, and transmission and differential lubrication.

Maximum pressure 2250 psi

BRAKES Hydraulically power actuated, disk-type operating in oil

ELECTRICAL SYSTEM:

Type 12-volt, negative grounded

Batteries Two, 6-volt, 75-plate 172-ampere-hour, 3 EH type, connected in series

Alternator 12-volt, 55-amp, with integral transistorized regulator

FRONT TIRES* 10.00-16, 6-ply

REAR TIRES* 20.8-38, 10-ply

FRONT WHEEL TREAD:

10.00-16 tire 57-1/2 to 83-1/4 in.

REAR WHEEL TREAD:

20.8-38 tire, regular axle . . . 63 to 108 in.

GROUND SPEEDS See page 11

DIMENSIONS:

Wheel base 106-1/2 in.

Over-all length 170-3/4 in.

Over-all height 106 in.

Height to steering wheel 87 in.

Over-all width 95-7/8 in.

Turning radius 151 in.

SHIPPING WEIGHT (With equipment for average field service, less fuel and ballast). Subtract 670 lbs. if equipped with Syncro-Range transmission. Add 575 lbs. if equipped with Roll-Gard.

Row-Crop 12,285 lbs.

**Additional tire sizes available. (Specifications and design subject to change without notice.)*

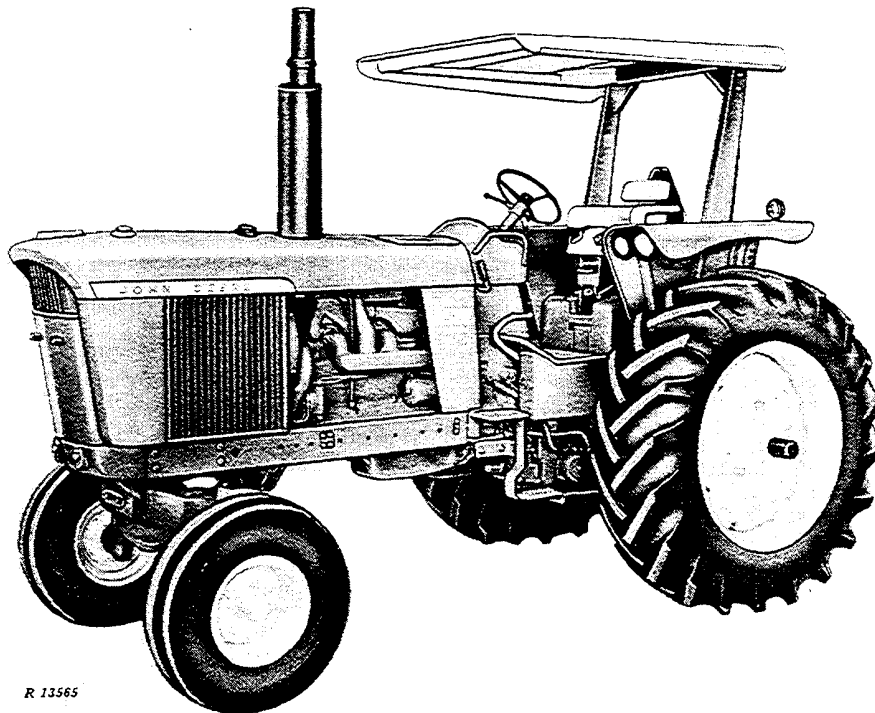

R 13565

Row-Crop Tractor with Turbocharged Diesel Engine, Power Shift Transmission and Roll-Gard



CONTROLS AND INSTRUMENTS

Before attempting to operate your new tractor, become familiar with the location and purpose of its controls and instruments. Additional information will be found on the page number following the control or instrument. World-wide graphic symbols are used to assist identification and operation.

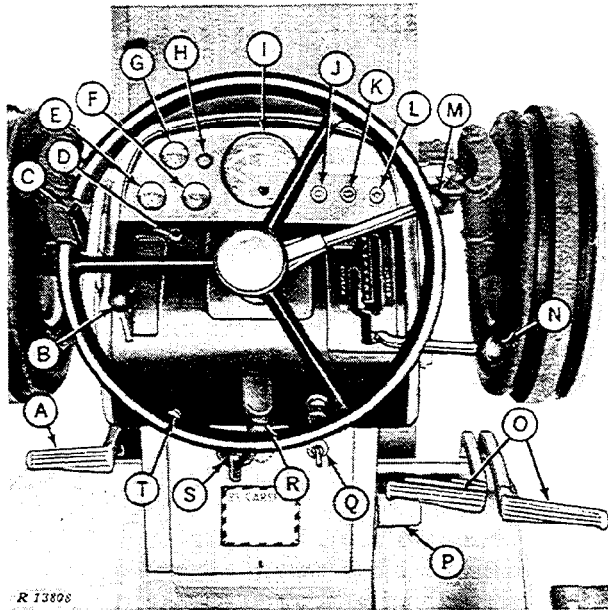

Tractor with Power Shift Transmission

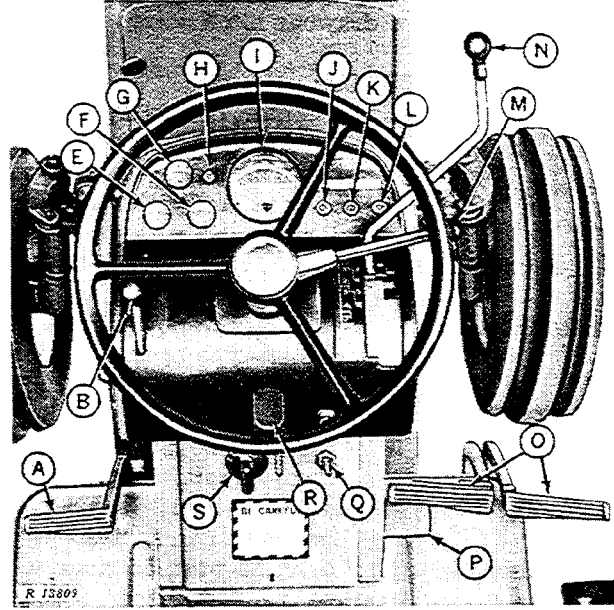

Tractor with Syncro-Range Transmission

- A - Clutch Pedal (Syncro-Range Tractors, page 14)
Inching Pedal (Power Shift Tractors, page 12)
- B - Power Take-Off Clutch Lever (page 35)
- C - Engine Disconnect Lever (Power Shift Tractors, page 8)
- D - Transmission Oil Filter Indicator Light (Power Shift Tractors, page 13)
- E - Transmission Oil Temperature Gauge (pages 13 and 14)
- F - Coolant Temperature Gauge
- G - Fuel Gauge
- H - Speed Indicator Knob (page 12)
- I - Speed-Hour Meter (pages 12 and 41)
- J - Alternator Indicator Light (page 6)
- K - Air Cleaner Indicator Light (pages 6 and 44)
- L - Oil Pressure Indicator Light (page 6)
- M - Hand Throttle (page 9)
- N - Shift Lever (Syncro-Range Tractors, page 14)
Speed Selector (Power Shift Tractors, page 12)
- O - Brake Pedals (page 16)
- P - Foot Throttle (page 10)
- Q - Key Switch (pages 6, 7, and 10)
- R - Ether Starting Fluid Adapter (page 7)
- S - Light Switch (page 22)
- T - Disconnect Lever Latch (Power Shift Tractors, page 8)

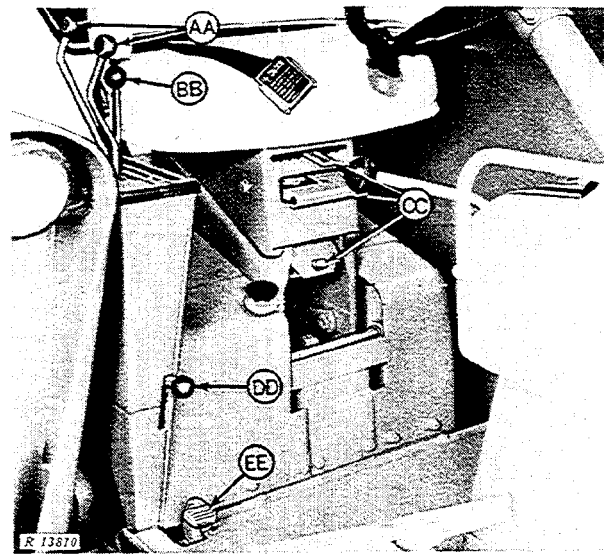

- AA - Remote Cylinder Operating Levers (page 31)
- BB - Rockshaft Control Lever (page 24)
- CC - Seat Controls (page 11)
- DD - Rockshaft Selector Lever (page 25)
- EE - Differential Lock Pedal (page 15)

INDICATOR LIGHTS

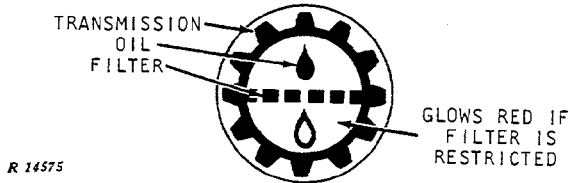
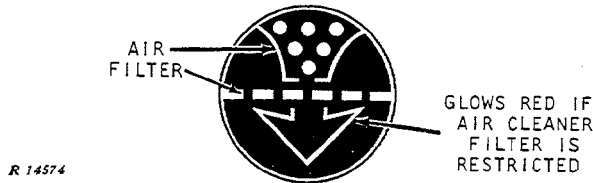
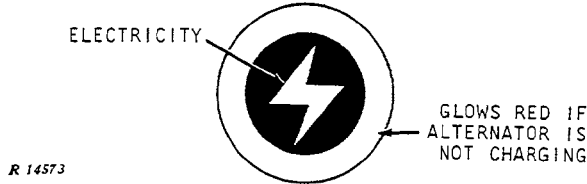
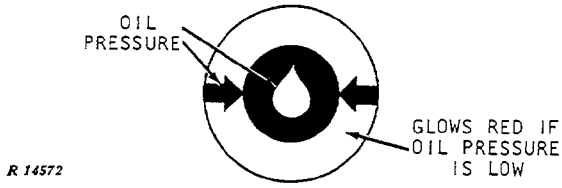

GAUGES

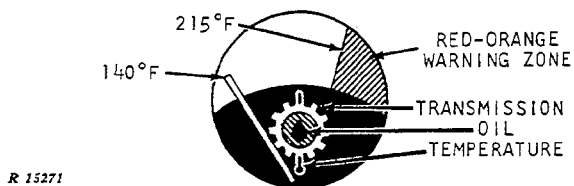
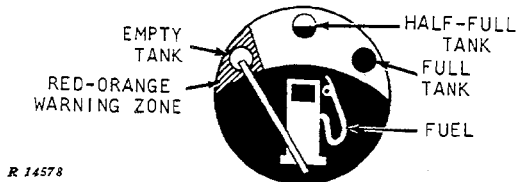
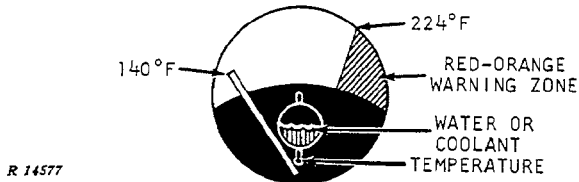

CONTROL SYMBOLS

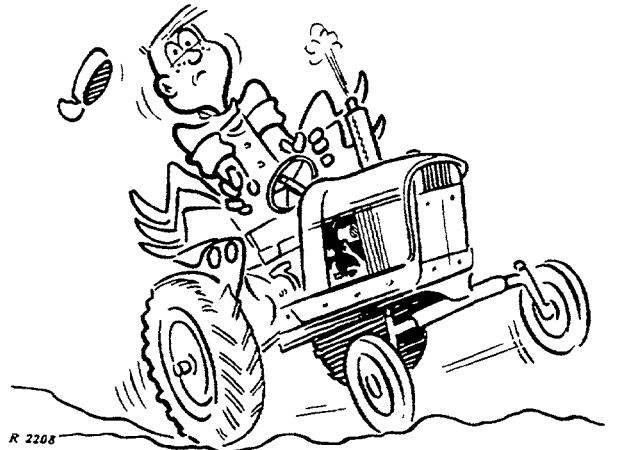
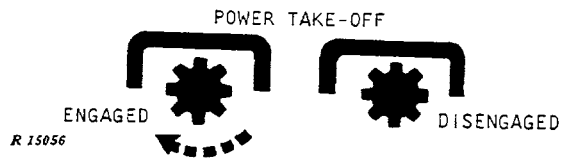
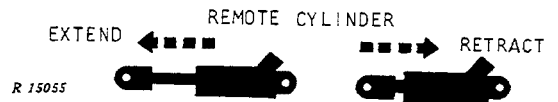
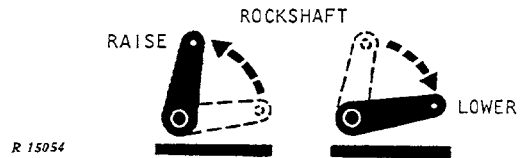
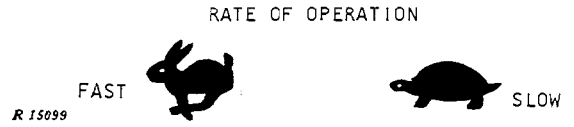

CAUTION: Fast driving causes many accidents. Couple the brake pedals together and always drive at a safe speed.



OPERATION

Complete instructions for operating your tractor safely and efficiently are given on the following pages. By following these directions carefully, you can be sure that you are taking full advantage of the many features built into your tractor.

OPERATING THE ENGINE

PRESTARTING CHECKS

Perform the following checks and services before starting the engine for the first time each day:

- (1) Check the engine crankcase oil level - see page 45.
- (2) Check the radiator coolant level - see page 46.
- (3) Check the fuel pump sediment bowl. See page 46.
- (4) Lubricate the wide-swing drawbar, draft link support, front axle pivot pins, steering knuckle pins, steering bellcrank, and steering cylinder fittings. See page 46.
- (5) Grease the front wheel bearings if the tractor has been operated in extremely wet or muddy conditions - see page 47.
- (6) Make sure the fuel shut off valve on the fuel tank is open. See page 52.

STARTING THE DIESEL ENGINE

NOTE: If the prevailing temperature is 40 degrees Fahrenheit or lower, it may be necessary to use a cold weather starting aid to start the engine (page 7).

Perform the Prestarting checks listed above.

- (1) See that the shift lever or the speed selector is in the "PARK" position. Depress the clutch pedal or the inching pedal.
- (2) PLACE THE HAND THROTTLE IN THE 1200 RPM POSITION, approximately one-third of its travel downward.

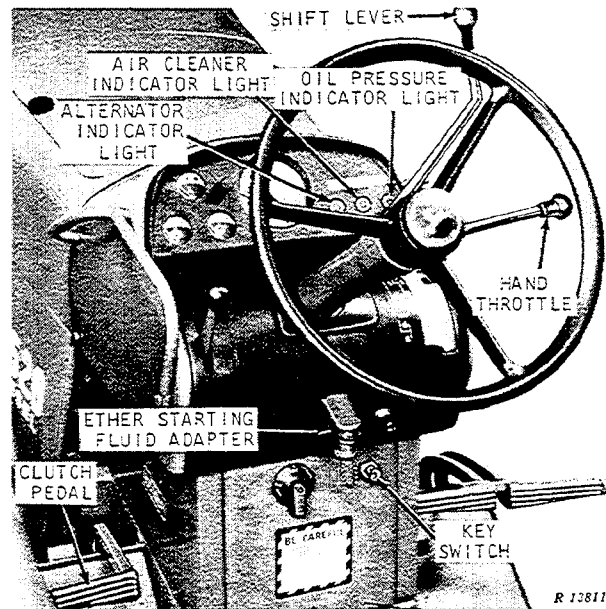

Starting Controls

(3) Turn the key switch clockwise to the first position. The alternator and oil pressure indicator lights should glow. Turning the key switch further to the start position should cause the air cleaner indicator light and, on power shift tractors, the transmission oil indicator light to glow. If any light fails to glow, turn off the key switch and determine the cause.

(4) Turn the key switch all the way to the right to start the engine. Do not operate the starter for more than 30 seconds at a time. To do so may overheat the starter. If the engine does not start the first time, wait for a minute or two before trying again. If it does not start after four attempts, see "Trouble Shooting."

If the key switch is released before the engine starts, wait until the starter and the engine stop before trying again. This will prevent possible damage to the starter.

Before the starter will operate, the shift lever or the speed selector lever must be in "PARK" or neutral.

(5) After the engine starts, the indicator lights should go out. The transmission oil filter indicator light may continue to glow when the oil is cold. If any other light continues to glow after the engine has been running 10 seconds, stop the engine and determine the cause.

If the power shift transmission engine disconnect clutch was disengaged, engage the clutch immediately after starting the engine. This will prevent damage to the tractor.

After starting the engine, do not accelerate or apply a load until the engine oil pressure indicator light goes out. In cold weather or after the engine has been idle for several weeks, idle the engine for several minutes at speeds below 1000 rpm to insure turbocharger lubrication before accelerating or applying a load.

Should the engine be killed when operating under load, immediately restart the engine to prevent overheating caused by stopping the flow of oil for turbocharger cooling and lubrication.

When starting the engine after the tractor has been in storage, disconnect the injection pump electrical shut-off solenoid wire, and crank the engine with the starter until the engine oil pressure indicator light goes out. Do not operate the



R 2206

CAUTION: Before starting the tractor engine, be sure there is plenty of ventilation. Never operate the tractor in a shed or garage.

starter more than 30 seconds at a time. After the indicator light goes out, reconnect the injection pump electrical shut-off solenoid wire and start the engine.

COLD WEATHER STARTING AIDS

For cold weather starting, the diesel tractor is equipped with an ether starting fluid adapter. The Power Shift transmission tractor is equipped with an engine disconnect lever. Other starting aids are available from your John Deere dealer.

These aids are effective at low temperatures, only when the engine is otherwise operating satisfactorily. They will not correct such deficiencies as low battery charge, crankcase oil of heavy viscosity, and high electrical resistance which may prevent the engine from starting.

ETHER STARTING FLUID ADAPTER

The diesel tractor is equipped with this adapter which is used to inject atomized starting fluid into the engine air intake system. Pressurized cans of starting fluid are available from your John Deere dealer.

To use the can of starting fluid, remove the safety cap and plastic spray button from the can. Remove the cap from the adapter and position the can under the adapter.

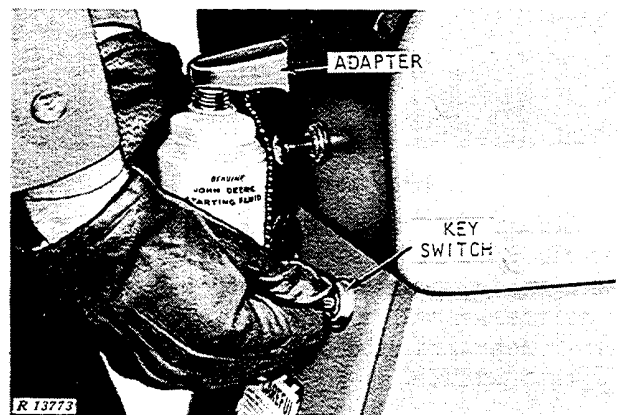

Injecting Starting Fluid

To inject a "shot" of starting fluid, momentarily push up on the can.

CAUTION: To avoid damage, turn engine with starter one or two revolutions before injecting starting fluid. Inject starting fluid only while the engine is turning.

8 Operation - Engine

Relax pressure on the can between "shots" of starting fluid. Stop injecting fluid after the engine starts. If the engine begins to die during the first few minutes of operation, inject another "shot" of fluid. When the engine is operating satisfactorily, remove the can from the adapter and replace the safety cap on the can.

Be sure to install the cap on the adapter when it is not in use. This will prevent dust from being drawn into the engine.

Store starting fluid cans where they will not be subject to extreme cold or warm temperatures. For best results, store fluid at room temperature.

CAUTION: Ether starting fluid is highly flammable.

ENGINE DISCONNECT LEVER (Power Shift Tractors)

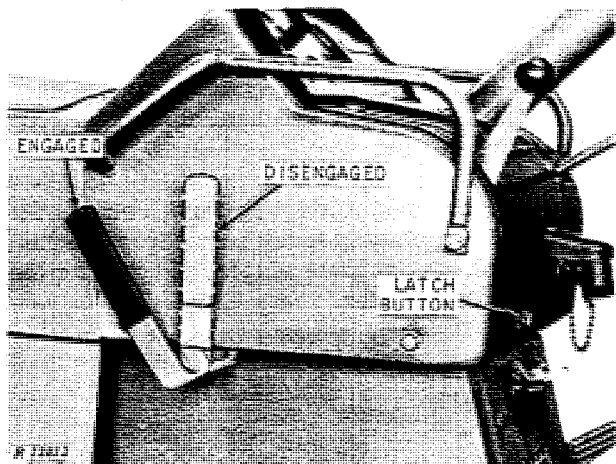

Engine Disconnect Lever

During cold weather, the starter speed on Power Shift tractors may be increased by disengaging the engine disconnect lever so that the transmission will not turn. To do so, pull the lever rearward until it is latched in the disengaged position.

Immediately after starting the engine, engage the clutch by pulling the lever slightly rearward, pushing in on the latch button, and allowing the lever to move forward to the engaged position.

CAUTION: Operating the engine with the engine disconnect lever disengaged will damage the tractor. Be sure to engage it as soon as the engine starts. Never attempt to start Power Shift tractor by towing or pushing.

SHUTTING OFF HYDRAULIC PUMP

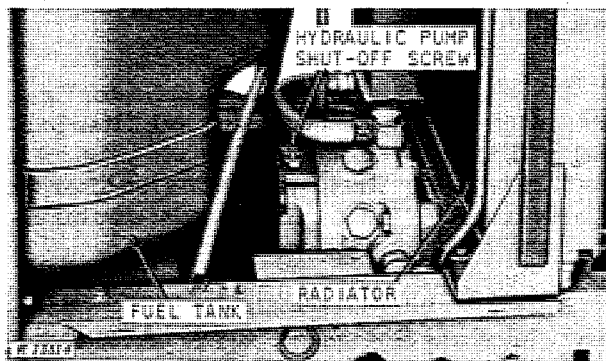

Hydraulic Pump Shut-Off Screw

If the tractor has a hydraulic pump shut-off screw (available from your John Deere dealer), the starter speed may be increased during cold weather by shutting off the hydraulic pump so it will not build up pressure. To do so, turn the shut-off screw in (clockwise) one turn with a screwdriver. Then turn the screw in by hand until resistance is felt. Turn the screw in one more turn.

After the engine has started, use a screwdriver to back the shut-off screw all the way out (turn the screw counterclockwise). The pump will now build up pressure.

NOTE: Oil will leak past the shut-off screw if it is not backed all the way out against the internal stop.

ELECTRIC CRANKCASE OIL AND COOLANT HEATERS

To facilitate cold weather starting, 115 volt electrical crankcase oil and tank-type coolant heaters are available from your John Deere dealer.

The crankcase oil heater is a 240 watt unit that may be installed in the front right-hand corner of the engine oil pan.

The coolant heater is thermostatically controlled and mounts on the right side of the engine block.

Use of either one of these heaters will reduce drag on the engine, thereby improving starting.

CAUTION: To avoid shock or hazardous operation, always use a three-wire heavy-duty electrical cord equipped with three-wire connectors. If a two-to-three contact adapter is used at the wall receptacle, always connect the green wire to a good ground.

ADDITIONAL BATTERIES

Cold weather starting can be made easier by connecting an additional 12-volt battery in parallel with the two 6-volt batteries on the tractor.

CAUTION: Gas given off by batteries is explosive. To avoid injury or battery damage, avoid sparks near the batteries.

Make sure all electrical switches or accessories are turned off and make the last connection or the first disconnection at some point away from the battery.

Connect a jumper cable to the POSITIVE (+) post of a 12-volt booster battery and to the POSITIVE (+) post of the right-hand tractor battery that is connected to the starter. Connect one end of the other jumper cable to the negative post of the booster battery and to a good ground on the tractor frame away from the battery. Never connect jumper cables to pipes or thin sheet metal. (The negative post of the left-hand battery is grounded.)

NOTE: Reversed polarity booster battery connections may damage the alternator or electrical wiring.

See your John Deere dealer for additional booster battery information.

TRACTOR WARM-UP PERIOD

Always be sure the tractor is warmed up properly before operating under a full load.

A good way to do this is first to idle the engine at about 1500 rpm for 5 minutes and then operate it at about 1900 rpm for another 5 minutes.

It is good practice to operate the tractor for the first 30 minutes in a lower gear than is normally required for the load. This gives the oil a chance to circulate freely and prevents undue wear on engine or transmission parts.

ENGINE IDLING

Avoid unnecessary engine idling. Prolonged engine idling may cause the engine coolant temperature to fall below its normal range. This in turn causes crankcase oil dilution, due to incomplete fuel combustion, and permits formation of gummy deposits on valves, pistons, and piston

rings. It also promotes rapid accumulation of engine sludge and unburned fuel in the exhaust system.

When the tractor is to remain idle for a considerable length of time, stop the engine.

ENGINE SPEEDS

The tractor engine is designed to operate at working speeds ranging from 1500 to 2200 rpm. The engine can be operated at any speed in the working range to meet various operating conditions. Operate the engine at 1900 rpm to obtain the ASAE Standard PTO speeds.

In addition, engine speeds may be varied up to 2500 rpm to save you time when traveling on highways or on smooth-surfaced roads.

Normal slow idle speed is approximately 800 rpm.

See page 49 to check engine idle speeds.

USING HAND THROTTLE

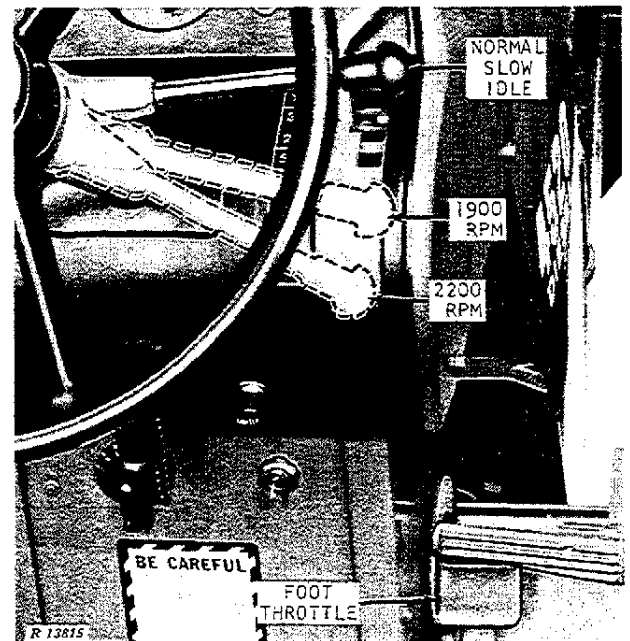

Range of Hand Throttle Positions

Use the hand throttle to select slow idle or any of the variable governed speeds from 1500 to 2200 rpm.

Push the throttle upward to obtain the slow idle speed of 800 rpm. To obtain the 1900 rpm

load speed, pull the throttle downward to the first stop. Placing the throttle halfway between slow idle and 1900 rpm gives the 1500 rpm speed. Engine speeds between 1500 rpm and 1900 rpm may be selected by moving the lever between these two positions.

To obtain working speeds above 1900 rpm, pull out on the knob at the end of the hand throttle. With the knob pulled out, pull the throttle downward as far as it will go. This is the 2200 rpm load speed position. Engine speeds between 1900 rpm and 2200 rpm may be selected by moving the lever between these two positions.

USING FOOT THROTTLE

The foot throttle is used to obtain engine transport speeds or to raise engine speed momentarily. When the foot throttle is pushed all the way downward, the engine operates at 2500 rpm load speed.

NOTE: The foot throttle should not be used to increase the normal engine working speed.

STOPPING THE ENGINE

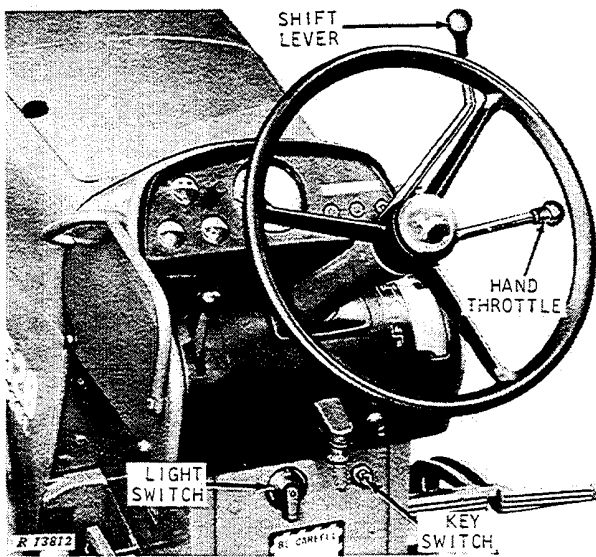

Stopping Controls

Place the shift selector or speed selector in "PARK" and allow the engine to idle a few minutes to cool the engine and turbocharger.

Lubrication and cooling of the turbocharger and some engine parts is provided by the engine lubricating oil. Therefore, sudden stopping of a

hot engine may allow some parts to overheat and cause possible damage.

After idling the engine for a few minutes, move the hand throttle up to the slow idle position and turn the key switch off.

After stopping the engine, remove the key from the switch to prevent tampering and unauthorized operation. Removing the key also prevents the switch from being accidentally left in the "on" or the "accessory" position and causing battery discharge.

Before dismounting, be sure all equipment is lowered to the ground, the light switch and other accessory switches are off, and the transmission is in "PARK."

BREAKING IN THE ENGINE

If the coolant temperature rises to the warning zone on the gauge, shift to a lower gear to reduce the load on the engine. Be sure to follow the special break-in lubrication instructions given on page 41.

With the following exceptions, the engine is ready for normal operation:

During the first 20 hours, it is not recommended to use the foot throttle. To facilitate break-in, avoid prolonged periods of engine idling, for the first 100 hours of service.

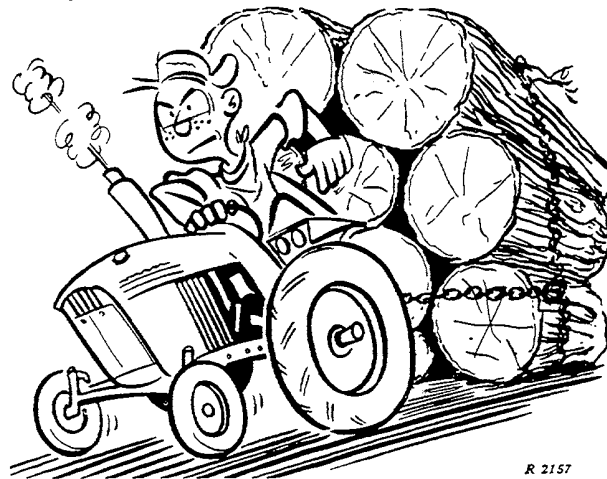

R 2157

An overloaded tractor will have a short service life.

OPERATING THE TRACTOR

SEAT

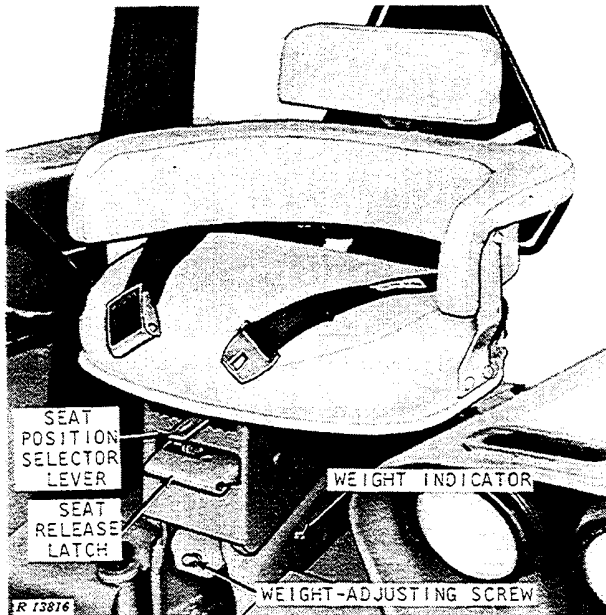

Seat Controls

The deluxe foam-padded suspension seat contains a steel compression spring and shock absorber to provide "Float-Ride" comfort.

Use only warm water and a mild soap to clean the seat cushions. Never use solvents.

MOVING SEAT TO UPPER REAR POSITION

To move the seat up and back, stand up and lift the seat release latch. A counterbalance spring will move the seat to the upper rear position. Sit down to return the seat to the normal preset operating position.

ADJUSTING FOR HEIGHT AND WEIGHT OF OPERATOR

The seat can be adjusted to the height of the operator. With the seat in the upper rear position, shift the seat position selector lever between "short" and "tall" until the controls can be operated comfortably when you are seated.

The tension of the steel compression spring can be adjusted to conform to your weight. This enables the seat to "float" when you are traveling over rough ground. To make this adjustment, turn the weight-adjusting screw clockwise or counterclockwise until the indicator in the left-hand side of the seat conforms to your weight.

ADJUSTING COUNTERBALANCE SPRING

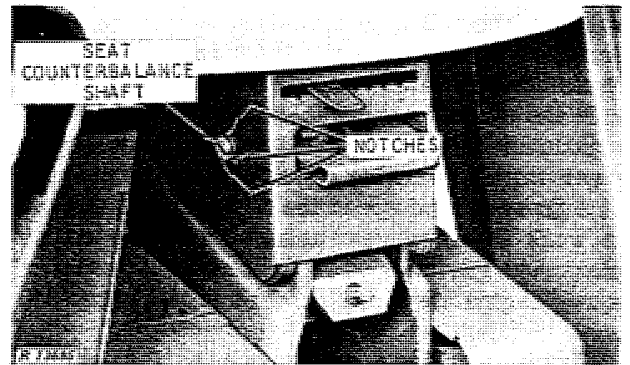

Seat Counterbalance Shaft

If the seat does not move fully to the rear when unlatched, adjust the counterbalance spring. With the seat in the upper rear position, insert a screwdriver in the counterbalance shaft slot. Push in to unlatch the shaft and turn the shaft counterclockwise. Align the latch in the end of the shaft with one of the pair of notches. Pull the screwdriver outward so the latch will engage the notches.

ROLL-GARD, SEAT BELT, AND CANOPY

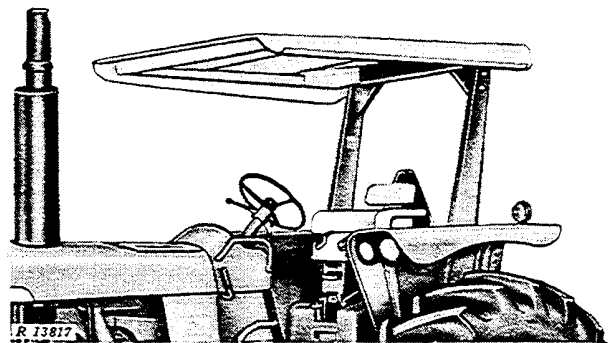

Roll-Gard, Seat Belt, and Canopy

A protective roll-gard with seat belt may be ordered for your tractor. A canopy that fits on top of the roll-gard and a weather enclosure are also available. See page 63 for more information.

CAUTION: Under almost all operating conditions:

1. Use of the seat belt with the optional John Deere Roll-Gard is recommended.
2. Use of a seat belt without roll-over protective equipment is not recommended.

SELECTING GROUND SPEED

Both transmissions provide eight forward speeds for each of the throttle positions that may be used. The Syncro-Range transmission has two reverse speeds, and the Power Shift transmission has four. These combinations enable the operator to balance speed and power for maximum economy and allow him flexibility to meet varying working conditions. For example, at a given ground speed the operator may choose to work in a low gear at high engine speed for maximum reserve power or in a higher gear at a lower engine speed for maximum fuel economy.

Engine working speeds may be varied between 1500 rpm and 2200 rpm. Engine transport speeds may be varied up to 2500 rpm. Tractor ground speeds shown in the chart below are only for engine speeds of 1500, 1900, 2200, and 2500 rpm.

Turn the speed indicator knob on the instrument panel until the gear selected shows on the speed indicator. The speed-hour meter needle will now indicate the tractor ground speed in miles per hour.

Avoid overloading the tractor. When this occurs, operate in a lower gear. If moving the throttle slightly will change engine speed, the engine is not overloaded or lugging. Overloading causes undue strain on parts, eventually resulting in poor operation and unnecessary repair and expense.

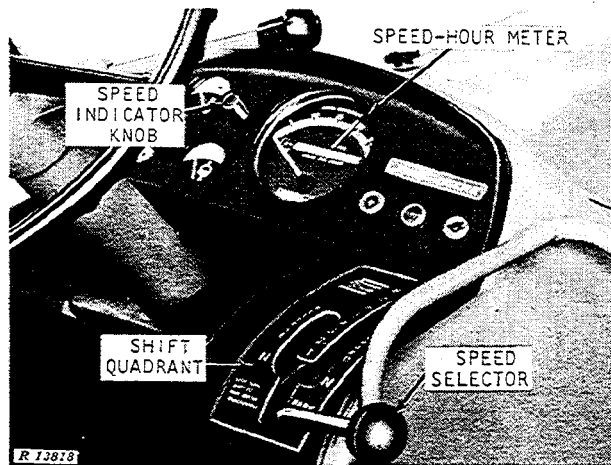

Speed Indicator Knob and Speed Selector

POWER SHIFT TRANSMISSION

SHIFTING

The Power Shift transmission can be shifted "on the go" or when the tractor is stopped by moving the speed selector to the desired gear. It is not necessary to use the inching pedal when starting out or when shifting.

To move the tractor forward, move the speed selector from neutral to the desired gear in the right-hand or forward side of the quadrant. Progressive shifting (one gear at a time) will result in smoother speed change.

TRACTOR GROUND SPEED IN MILES PER HOUR

NOTE: The following ground speeds are for 20.8-38 rear tires with a 32.9 inch loaded radius.

| Gear | Hand Throttle Operating Range | | | | | | Maximum Foot Throttle Speed | |
|-------------|-------------------------------|-------------|--------------|-------------|--------------|-------------|-----------------------------|-------------|
| | 1500 rpm | | *1900 rpm | | 2200 rpm | | 2500 rpm | |
| | Syncro-Range | Power Shift | Syncro-Range | Power Shift | Syncro-Range | Power Shift | Syncro-Range | Power Shift |
| 1st | 1.3 | 1.2 | 1.7 | 1.5 | 2.0 | 1.7 | 2.2 | 2.0 |
| 2nd | 2.1 | 1.7 | 2.7 | 2.1 | 3.1 | 2.5 | 3.6 | 2.8 |
| 3rd | 2.8 | 2.6 | 3.6 | 3.3 | 4.1 | 3.8 | 4.7 | 4.3 |
| 4th | 3.6 | 3.4 | 4.6 | 4.3 | 5.3 | 5.0 | 6.0 | 5.7 |
| 5th | 4.5 | 4.4 | 5.7 | 5.6 | 6.6 | 6.5 | 7.5 | 7.4 |
| 6th | 5.9 | 5.8 | 7.5 | 7.3 | 8.7 | 8.5 | 9.8 | 9.6 |
| 7th | 7.7 | 7.4 | 9.7 | 9.4 | 11.2 | 10.9 | 12.7 | 12.4 |
| 8th | 12.5 | 12.6 | 15.8 | 16.0 | 18.3 | 18.5 | 20.8 | 21.0 |
| 1st reverse | 2.7 | 1.4 | 3.5 | 1.8 | 4.0 | 2.1 | ... | ... |
| 2nd reverse | 4.4 | 2.1 | 5.6 | 2.6 | 6.4 | 3.0 | ... | ... |
| 3rd reverse | ... | 3.2 | ... | 4.1 | ... | 4.7 | ... | ... |
| 4th reverse | ... | 4.3 | ... | 5.6 | ... | 6.3 | ... | ... |

**1900 engine rpm gives the ASAE Standard 540 or 1000 rpm PTO speed. Some PTO-driven implements are operated at other speeds. See the implement operator's manual for detailed instructions.*

To reverse the tractor, move the speed selector rearward progressively (one gear at a time) to neutral. Then, move the lever to first gear in the left-hand or reverse side of the quadrant. A hand rail beside the speed selector may be used as an aid to shifting when traveling over rough ground.

Use the inching pedal when making emergency stops, when hitching to an implement, or whenever slower clutch engagement is required.

Reduce engine speed prior to making sudden extreme speed changes.

OPERATION

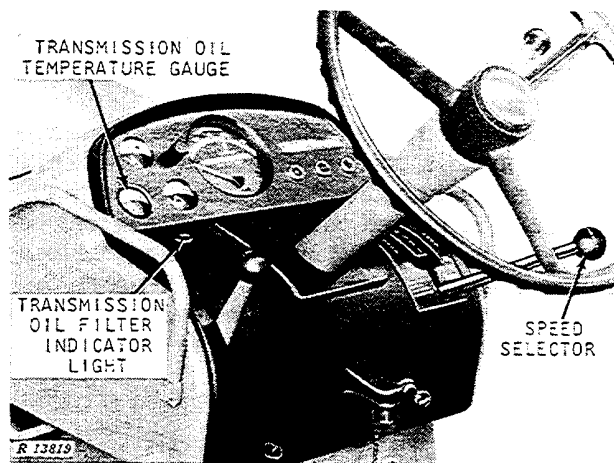

Transmission Instruments and Speed Selector

When operating a tractor with the Power Shift transmission, check the transmission oil temperature gauge and the transmission oil filter indicator light for satisfactory transmission operation.

If the indicator hand on the temperature gauge goes into the red zone, stop the tractor and clean all dirt and trash from the grille screens and the transmission hydraulic oil cooler core. See page 56. Also check for proper transmission-hydraulic oil level. If necessary, fill the system to the proper level. See page 48. If this does not correct the difficulty, call your John Deere dealer. Do not operate the tractor when the temperature indicator hand is in the red zone.

Should the transmission oil filter indicator light flicker on and off when using a hydraulic function at engine speeds above 2200 rpm, change

the transmission oil filter element (front element) at the earliest opportunity. Under normal conditions, change the filter at the next refueling and servicing. The amount of safe operating time with the light flickering depends on how fast the filter is clogging.

Change the filter **IMMEDIATELY** if any of the following symptoms are noted: the indicator lamp glows continuously, high transmission oil temperature, slipping of the transmission, or slow hydraulic function response particularly with single-acting cylinders. **DO NOT** allow the transmission to slip.

If the light goes out after being on for a while at normal temperatures, change the filter because it may have ruptured.

SHIFT ADJUSTMENT

The transmission speed-of-shift may be adjusted for rapid shift or for slow, smoother shift. When pulling a heavy load, such as a plow, adjust for a rapid shift to prevent the tractor from stopping while shifting. When pulling a light load, adjust for a slow, smooth shift.

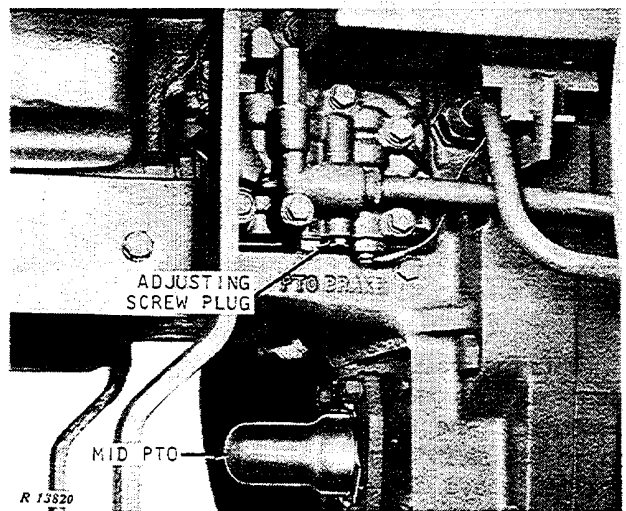

Speed-of-Shift Adjusting Screw Plug

To adjust the speed-of-shift, stop the engine and remove the adjusting screw plug at the bottom of the valve housing on the left-hand side of the tractor. With a screwdriver, turn the adjusting screw in (clockwise) to slow down the shifting. To speed up the shifting for heavy loads, turn the adjusting screw out. Turn the

14 Operation - Tractor

adjusting screw one-half turn at a time until the desired speed-of-shift is obtained.

Install the adjusting screw plug to prevent oil leakage.

SYNCRO-RANGE TRANSMISSION

Do not operate the tractor when the transmission oil temperature is too high. See page 13.

NOTE: To prevent unnecessary wear, never "ride" the clutch or brake pedals by resting the feet on the pedals.

SHIFTING BETWEEN STATIONS

The shift quadrant has four shift stations. Stations No. 1 and 2 have two forward speeds and one reverse speed. Stations No. 3 and 4 have two forward speeds only.

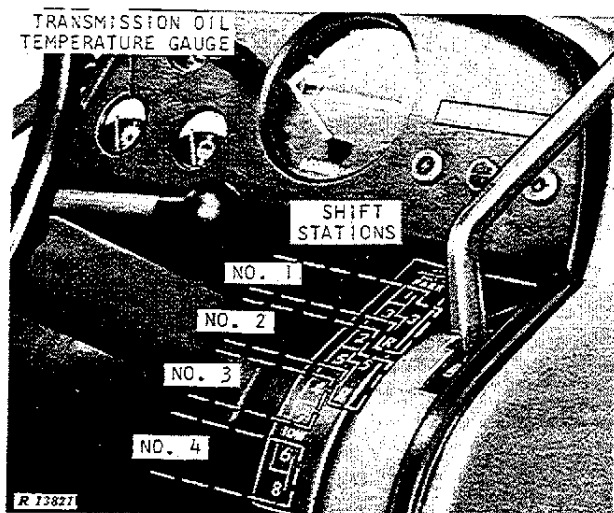

Syncro-Range Transmission Shift Quadrant

With the tractor stopped and the clutch pedal depressed, move the shift lever to a neutral position at the left side of the quadrant. Then move the shift lever to the station that has the desired speed. Move the lever to the right and into the speed desired.

Gradually release the clutch pedal to take up the load smoothly.

SHIFTING WITHIN STATIONS

With the clutch pedal depressed, the transmission can be shifted from one forward speed to the other forward speed within the same station while the tractor is in motion. For instance, you can shift between 1st and 3rd gears, 2nd and 5th gears, 4th and 7th gears, and 6th and 8th

gears without stopping the tractor.

You can also shift from a forward speed to the reverse speed within the same station without stopping the tractor. However, to avoid injury and damage to the tractor, do so only at slow ground speed. Gradually release the clutch pedal to engage the clutch.

PARKING THE TRACTOR

CAUTION: Be sure the tractor is stopped before placing the shift lever or speed selector in the "PARK" position.

SYNCRO-RANGE TRACTORS

On Syncro-Range tractors, move the shift lever to a neutral position at the left side of the quadrant. Then push the shift lever all the way forward into "PARK."

To shift from "PARK" when the tractor is not parked on a steep incline, simply move the shift lever rearward to the station desired. When the tractor is parked on a steep incline it may be necessary to do the following to relieve the load on the transmission park lock. Depress the clutch pedal and pull the shift lever rearward against spring pressure into the No. 1 shift

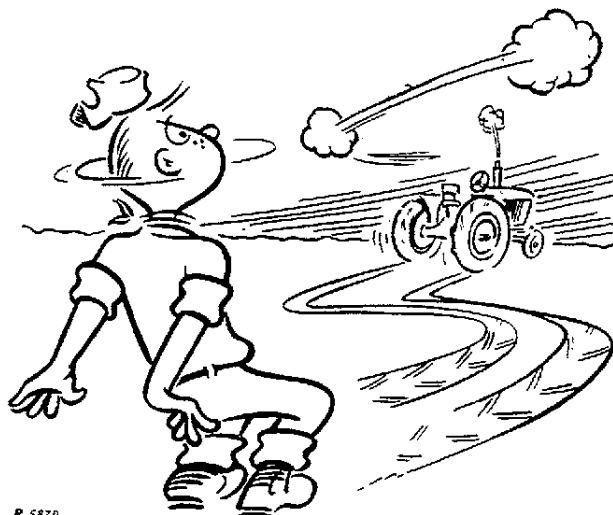

CAUTION: Whenever the tractor is stopped, place the shift lever or speed selector in the "PARK" position BEFORE DISMOUNTING. Never dismount from the tractor when it is in motion.



Suggest:

If the above button click is invalid.

Please download this document

first, and then click the above link

to download the complete manual.

Thank you so much for reading

station. Then shift into a forward or reverse gear that will move the tractor UP THE INCLINE. VERY SLOWLY engage the clutch and the transmission will shift out of "PARK."

POWER SHIFT TRACTORS

On Power Shift tractors, move the speed selector rearward and to the right into the "PARK" position shown in the illustration on page 12. Shifting from "PARK" to neutral usually releases the park locking action. If tractor is parked on a steep incline, it may be necessary to move the speed selector to the 1st speed forward or reverse to move the tractor up the incline.

TOWING THE TRACTOR

CAUTION: Never tow the tractor at high speeds. Do not tow tractor without the engine running to maintain power operation of steering and brakes.

When towing the tractor, the transmission-hydraulic system should be at the "FULL" mark. If the front end is raised, add one gallon of oil for each six inches the front end is raised. Be sure differential lock is disengaged.

IMPORTANT: Always place the tow lever or shift lever in "TOW." Do not attach towing means to front wheel knuckles or steering mechanism.

POWER SHIFT TRACTORS

When towing a Power Shift tractor, open the battery compartment, pull out on tow lever latch, and move the lever rearward until the latch holds the lever in "TOW" position. Place the speed selector in neutral to move the tractor.

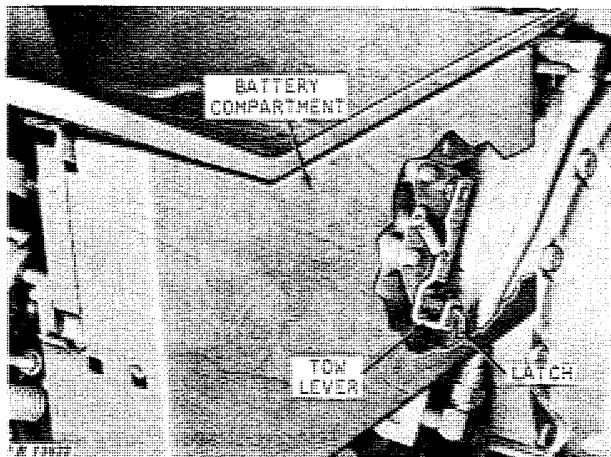

Tow Lever on Power Shift Tractor

To operate the tractor after towing, place the speed selector in "PARK." Pull out on the tow lever latch and allow the spring to move the lever forward. If the lever does not latch in the forward position, attempt to move the tractor slowly and the spring will move the lever forward.

IMPORTANT: To prevent transmission damage, always place the tow lever in "Tow" position when towing Power Shift tractors. Do not tow the tractor to start the engine.

SYNCRO-RANGE TRACTORS

The shift quadrant for the Syncro-Range transmission has a "TOW" position. Whenever a Syncro-Range tractor is to be towed, move the shift lever to this position.

DIFFERENTIAL LOCK

Your tractor may be equipped with a differential lock that will turn both rear wheels at the same speed. This prevents the usual loss of power when one wheel is slipping.

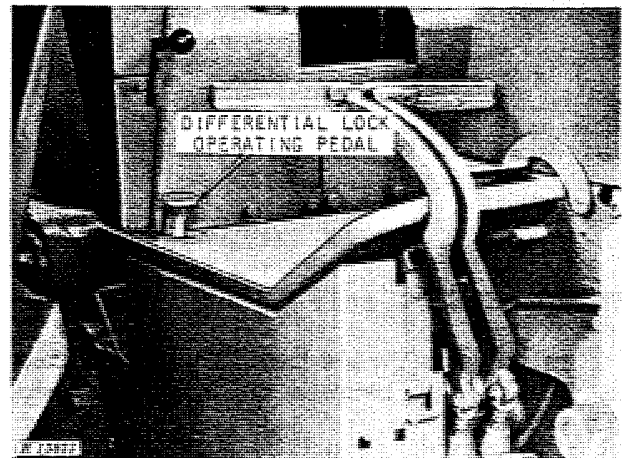

Differential Lock Operating Pedal

When one wheel starts to slip or whenever desired, engage the differential lock by depressing the operating pedal located at the right-rear side of the platform. When no longer required and before turning the tractor, disengage the differential lock by depressing one or both brake pedals. The front wheels should be in the straight ahead position when disengaging the differential lock.

CAUTION: Do not operate the tractor at high speeds or attempt to turn the tractor with the differential lock engaged.

<https://www.ebooklibonline.com>

Hello dear friend!

Thank you very much for reading.

Enter the link into your browser.

The full manual is available for immediate download.

<https://www.ebooklibonline.com>