

**JOHN DEERE**  
**WORLDWIDE COMMERCIAL & CONSUMER**  
**EQUIPMENT DIVISION**

---

---



**Compact Utility Tractors**  
**4500, 4600 and 4700**

OMLVU1185 G0

**OPERATOR'S MANUAL**



European Version  
Litho in U.S.A.

# INTRODUCTION

---

## Thank You for Purchasing a John Deere Product

We appreciate having you as a customer and wish you many years of safe and satisfied use of your machine.

## Using Your Operator's Manual

This manual is an important part of your machine and should remain with the machine when you sell it.

Reading your operator's manual will help you and others avoid personal injury or damage to the machine. Information given in this manual will provide the operator with the safest and most effective use of the machine. Knowing how to operate this machine safely and correctly will allow you to train others who may operate this machine.

This manual and safety signs on your machine may also be available in other languages (see your John Deere dealer to order).

Sections in your operator's manual are placed in a specific order to help you understand all the safety messages and learn the controls so you can operate this machine safely. You can also use this manual to answer any specific operating or servicing questions. A convenient index located at the end of this book will help you to find needed information quickly.

The machine shown in this manual may differ slightly from your machine, but will be similar enough to help you understand our instructions.

RIGHT-HAND and LEFT-HAND sides are determined by facing in the direction the machine will travel when going forward. When you see a broken line arrow (----->), the item referred to is hidden from view.

Before delivering this machine, your dealer performed a predelivery inspection to ensure best performance.

## Machine Use

This Tractor is designed solely for customary agricultural use, for park and amenity area maintenance and for winter work. Use in any other way is considered as contrary to the intended use.

The manufacturer accepts no liability for damage or injury resulting from this misuse, and these risks must be borne solely by the user. Compliance with and strict adherence to the conditions of operation, service and repair as specified by the manufacturer also constitute essential elements for the intended use.

This tractor should be operated, serviced and repaired only by persons familiar with all its particular characteristics and

acquainted with the relevant safety rules (accident prevention). The accident prevention regulations, all other generally recognized regulations on safety and occupational medicine and the road traffic regulations must be observed at all times.

Setting fuel delivery beyond published factory specifications or otherwise overpowering will result in loss of warranty protection for this machine.

Any arbitrary modifications carried out on this machine will relieve the manufacturer of all liability for any resulting damage or injury.

## Special Messages

Your manual contains special messages to bring attention to potential safety concerns, machine damage as well as helpful operating and servicing information. Please read all the information carefully to avoid injury and machine damage.



**CAUTION: Avoid injury! This symbol and text highlight potential hazards or death to the operator or bystanders that may occur if the hazards or procedures are ignored.**

**IMPORTANT: Avoid damage! This text is used to tell the operator of actions or conditions that might result in damage to the machine.**

**NOTE: General information is given throughout the manual that may help the operator in the operation or service of the machine.**

# PRODUCT IDENTIFICATION

## Record Identification Numbers

### Compact Utility Tractor with Gear or Hydrostatic Transmissions

4500 PIN (155001 - )

4600 PIN (166001 - )

4700 PIN (179001 - )

If you need to contact an Authorized Service Center for information on servicing, always provide the product model and identification numbers.

You will need to locate the identifications numbers for the product. Record the information in the spaces provided below.

DATE OF PURCHASE:

\_\_\_\_\_

DEALER NAME:

\_\_\_\_\_

DEALER PHONE:

\_\_\_\_\_

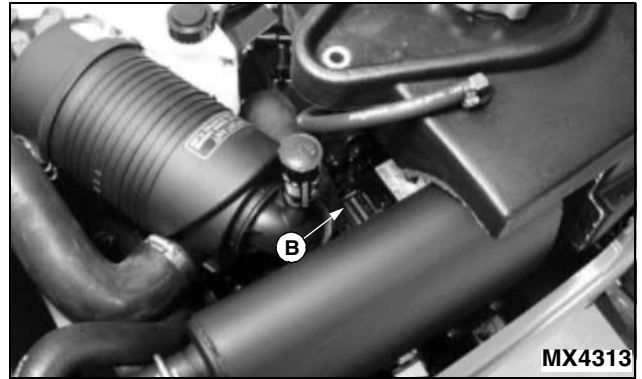

ENGINE SERIAL NUMBER (B):

-----



PRODUCT IDENTIFICATION NUMBER (A):

-----

**<https://www.ebooklibonline.com>**

Hello dear friend!

Thank you very much for reading.

Enter the link into your browser.

The full manual is available for immediate download.

**<https://www.ebooklibonline.com>**

---

---

# TABLE OF CONTENTS

---

---

Safety .....	1
Operating .....	10
Replacement Parts .....	53
Service Intervals .....	54
Service Lubrication .....	56
Service Engine .....	58
Service Transmission .....	72
Service Electrical .....	75
Service Miscellaneous .....	85
Troubleshooting .....	96
Storage .....	102
Assembly .....	104
Specifications .....	106
Index .....	115

All information, illustrations and specifications in this manual are based on the latest information at the time of publication. The right is reserved to make changes at any time without notice.

COPYRIGHT© 2000  
Deere & Co.

John Deere Worldwide Commercial and  
Consumer Equipment Division  
Horicon, WI

All rights reserved  
Previous Editions  
COPYRIGHT©

OMLVU1185 G0 - English

# SAFETY

## Pictorial Safety Signs

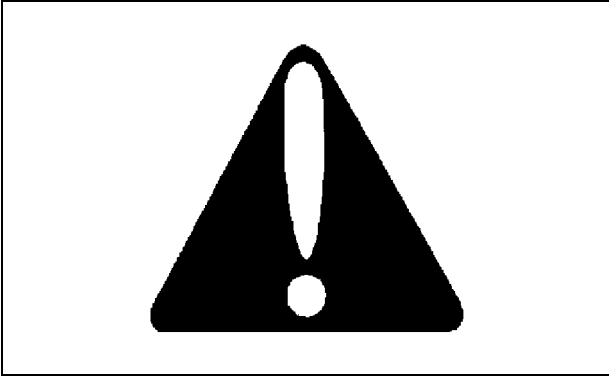

At several important places on this machine safety signs are affixed intended to signify potential danger. The hazard is identified by a pictorial in a warning triangle (▲). An adjacent pictorial provides information how to avoid personal injury. These safety signs, their placement on the machine and a brief explanatory text are shown in this Safety section.

## WARNING: KEEP RIDERS OFF

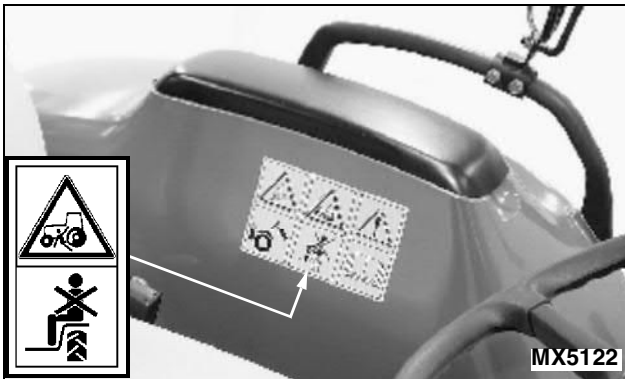

Only allow the operator on the machine. Keep riders off.

Riders on the machine may be struck by foreign objects or thrown off the machine causing serious injury.

Riders obstruct the operator's view resulting in the machine being operated in an unsafe manner.

## CAUTION: READ OPERATOR'S MANUAL

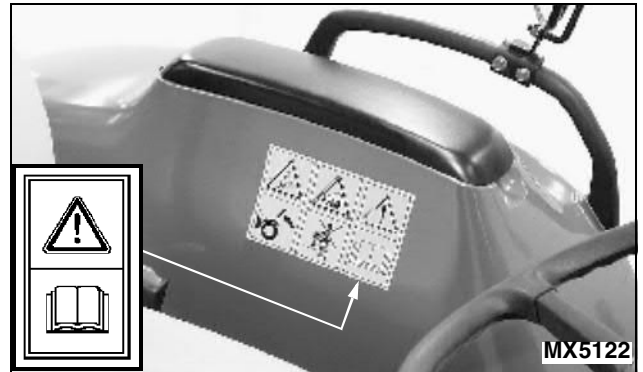

1. Read Operator's Manual before operating this tractor.
2. Keep all shields in place.
3. Hitch towed loads only to drawbar to avoid rearward upset.
4. Make certain everyone is clear of machine before starting engine or operation.
5. Keep all riders off tractor and equipment.
6. Keep hands, feet and clothing away from power-driven parts.
7. Reduce speed when turning or applying individual brakes or operating around hazards on rough ground or steep slopes.
8. Couple brake pedals together for road travel.
9. Use flashing warning lights on highway unless prohibited by law.
10. Stop engine, lower implement to ground and shift to "PARK" or set brake(s) securely before dismounting.
11. Wait for all movement to stop before servicing machinery.
12. Remove key if leaving tractor unattended.

# SAFETY

## WARNING: AVOID CRUSHING

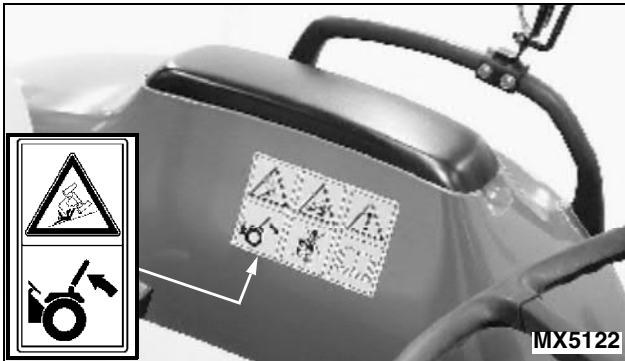

- Keep Rollover Protective Structure fully extended.
- Do not jump if machine tips.
- Use seat belt.

When structure must be down:

- Do Not use seat belt.
- Drive with extra care.

## CAUTION: HOT SURFACE

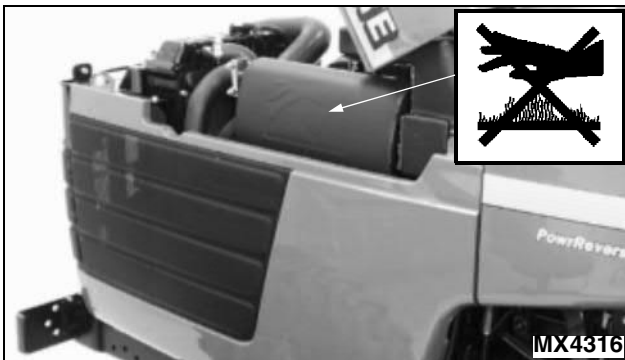

**Picture Note:** No-text warning molded into muffler.

DO NOT touch engine muffler, it may be hot.

## DANGER-POISON: SHIELD EYES, EXPLOSIVE GASES CAN CAUSE BLINDNESS OR INJURY

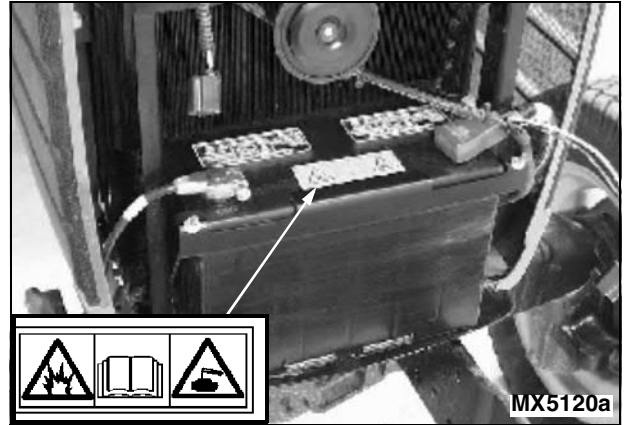

No sparks, flames, smoking.

Sulfuric acid can cause blindness or severe burns.

Flush eyes immediately with water.

Get medical help fast.

Keep out of reach of children.

Do not tip.

Keep vent caps tight and level.

## ROLLOVER PROTECTION CERTIFICATION PLATE



# SAFETY

## DRAWBAR EEC LABEL

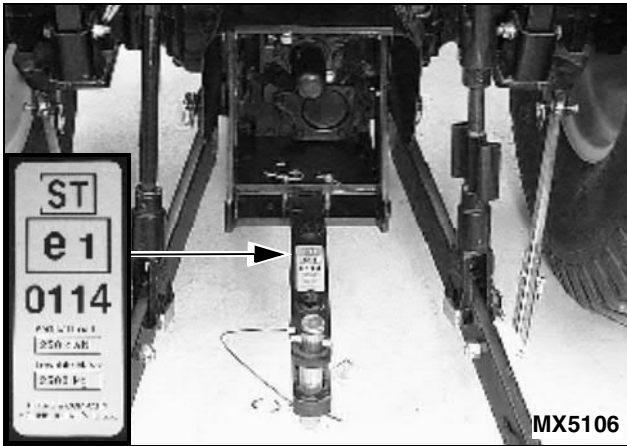

## CAUTION: UNEXPECTED HITCH MOVEMENT

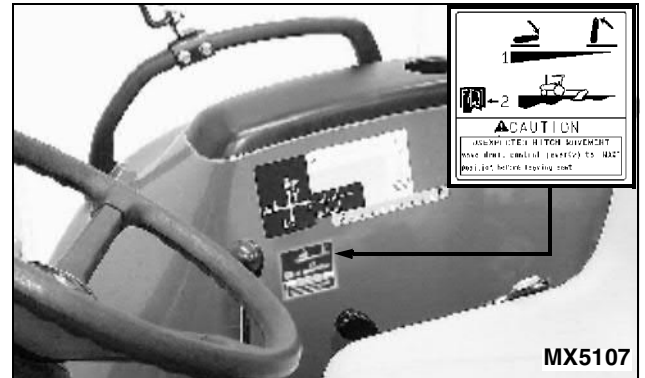

**Picture Note:** Label installed on tractors equipped with optional draft sensing kit.

Move draft control lever (2) to "MAX" position before leaving seat.

## WAGON HITCH EEC INFORMATION

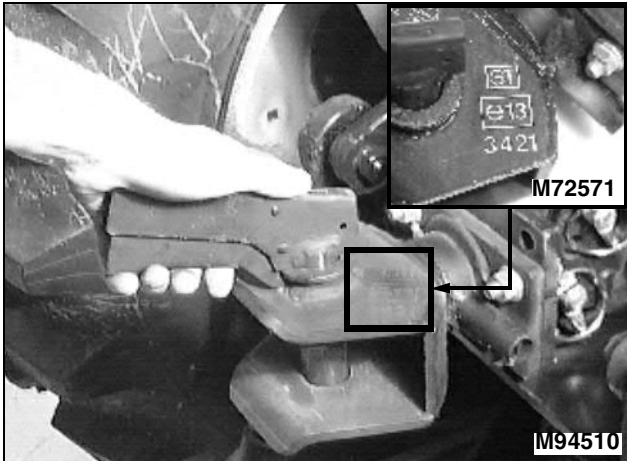

**Picture Note:** Information stamped into top of hitch

## Operating Safely

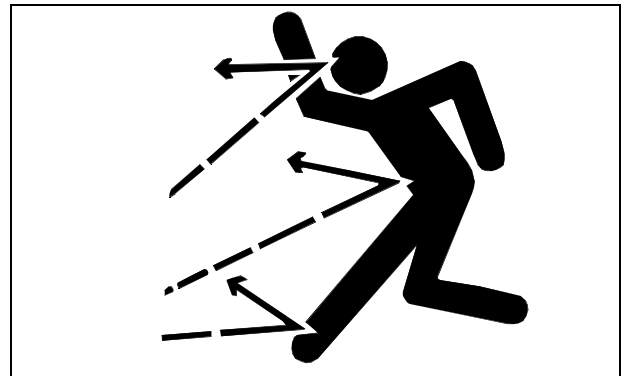

## CAB EEC PLATE



- Inspect machine before you operate. Be sure hardware is tight. Repair or replace damaged, badly worn, or missing parts. Be sure guards and shields are in good condition and fastened in place. Make any necessary adjustments before you operate.
- Check before each use that operator presence controls are functioning correctly. Test safety systems. Do not operate unless they are functioning correctly.
- Do not change the engine governor setting or overspeed the engine.
- Check brake action before you operate. Adjust or service brakes as necessary.
- Stop machine if anyone enters the area.
- If you hit an object, stop and inspect the machine. Make repairs before you operate. Keep machine and

# SAFETY

attachments properly maintained and in good working order.

- Do not leave machine unattended when it is running.
- Only operate during daylight or with good artificial light.
- Slow down and be careful of traffic when operating near or crossing roadways. Make sure to stop blades before crossing roads or sidewalks. Use care when approaching blind corners, shrubs, trees, or other objects that may obscure vision.
- Be aware of the mower discharge direction and make sure that no one is in the path of the discharge direction.
- Do not wear radio or music headphones while operating the machine. Safe operation requires your full attention.

## Checking Mowing Area

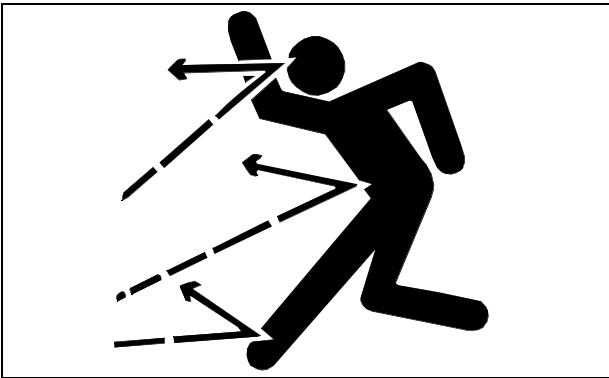

- Clear mowing area of objects that might be thrown. Keep people and pets out of mowing area.
- Study mowing area. Set up a safe mowing pattern. Do not mow where traction or stability is doubtful.
- Test drive area with mower lowered but not running. Slow down when you travel over rough ground.

## Parking Safely

1. Stop machine on a level surface, not on a slope.
2. Disengage PTO.
3. Lower attachments to the ground.
4. Lock park brake.
5. Stop engine.
6. Remove key.
7. Before you leave the operator's station, wait for engine and all moving parts to stop.

## Rotating Blades are Dangerous

HELP PREVENT SERIOUS OR FATAL ACCIDENTS:

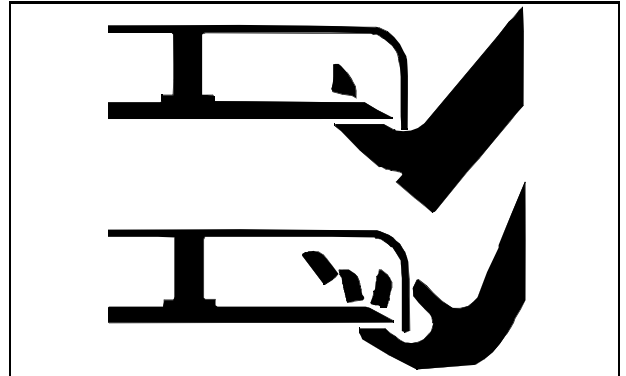

- Rotating blades can cut off arms and legs.
- Keep hands, feet and clothing away from mower deck when engine is running.
- Be alert at all times, drive forward carefully. People, especially children can move quickly into the mowing area before you know it.
- Before backing up, shut off PTO and look down and behind the machine carefully, especially for children.
- Do not mow in reverse.
- Shut off blades when you are not mowing.
- Do not operate machine if you are under the influence of drugs or alcohol.
- Park machine safely before inspecting or unplugging mower or bagger.

## PROTECT CHILDREN:

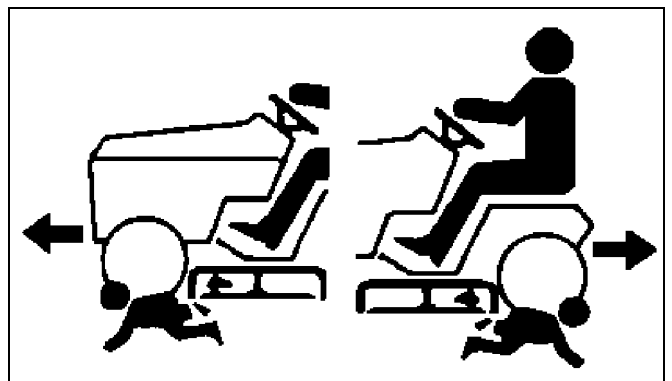

- Never assume that children will remain where you last saw them. Children are attracted to mowing activity, stay alert to the presence of children.
- Keep children indoors when you are mowing. Turn the machine off if a child enters the mowing area.
- Use extra care when you come to blind corners, shrubs,

---

# SAFETY

---

trees, or other objects that may block your vision.

- Do not let children or an untrained person operate the machine.
- Do not carry or let children ride on any attachment or machine even with the blades off. Do not tow children in a cart or trailer.

## Use Seat Belt Properly

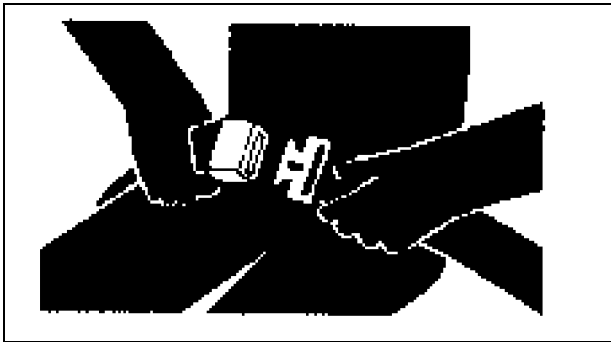

Use a seat belt when you operate with a Roll-Over Protective Structure (ROPS) to minimize chance of injury from an accident, such as an overturn.

Do not use a seat belt if operating without a ROPS.

## Operator Training Required

- The owner of the machine is responsible for training the users of the machine.
- The owner/user can prevent accidents with proper use of the machine. The owner/user is responsible for accidents or injuries occurring to themselves, other people or property.
- Do not allow operation of the machine by untrained persons.
- Read the operator manual and study the safety and operation sections before operating the machine.
- If the operator of the machine cannot read or understand this manual, the machine owner is responsible to explain this material to the operator. This publication is available in other languages.
- Operate the machine in an open, unobstructed area under the direction of an experienced operator.
- Learn the use of all controls.
- Operator practice is required to learn the moving, stopping, turning and other operating characteristics of the machine.

## Avoid Tipping

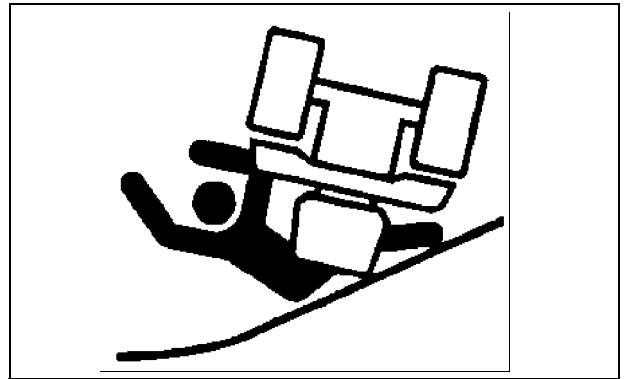

- Slopes are a major factor related to loss-of-control and tip-over accidents, which can result in severe injury or death. If you cannot back up the slope or if you feel uneasy on it, do not mow it.
- Do not drive where machine could slip or tip.
- Stay alert for holes and other hidden hazards in the terrain.
- Keep away from drop-offs, ditches and embankments.
- Slow down before you make a sharp turn or operate on a slope. Choose a low gear so that you will not have to stop or shift while on the slope.
- Limit loads to those you can safely control. Use only approved hitches when pulling loads or using heavy equipment. Use counterweights or wheel weights as required in this manual or your attachment manual.
- Use wheel weights for added stability when operating on slopes or using rear mounted attachments.
- Drive up and down a hill - not across. Turn slowly and turn downhill. Do not shift to neutral and coast downhill.
- Do not stop when going up hill or down hill. If machine stops going up hill, disengage mower blades and back down slowly.
- Mowing when grass is wet can cause reduced traction and sliding.
- Do not try to stabilize the machine by putting your foot on the ground.

# SAFETY

## Keep Riders Off

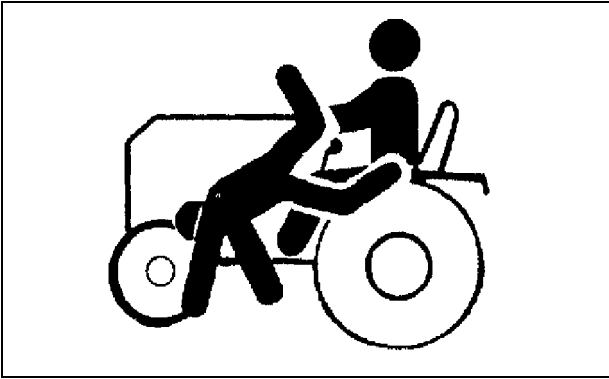

- Only allow the operator on the machine. Keep riders off.
- Riders on the machine or attachment may be struck by foreign objects or thrown off the machine causing serious injury.
- Riders obstruct the operator's view resulting in the machine being operated in an unsafe manner.

## Stay Clear of Rotating Drivelines

Entanglement in rotating driveline can cause serious injury or death.

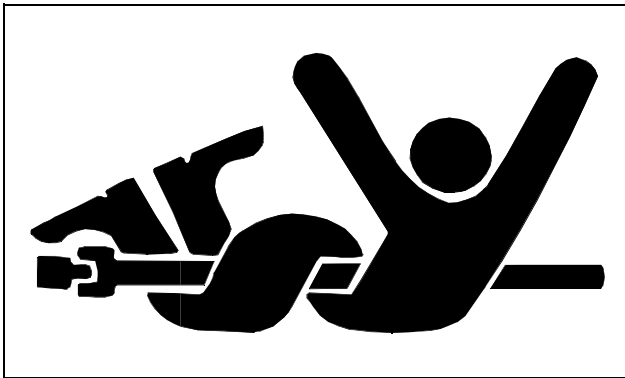

- Wear close fitting clothing.
- STOP the engine and be sure PTO driveline is stopped before getting near it.

## Checking Wheel Bolts

- A serious accident could occur causing serious injury if wheel bolts are not tight.
- Check wheel bolt tightness often during the first 100 hours of operation.
- Wheel hardware must be tightened to specified torque using the proper procedure anytime it is loosened.

## Wear Appropriate Clothing

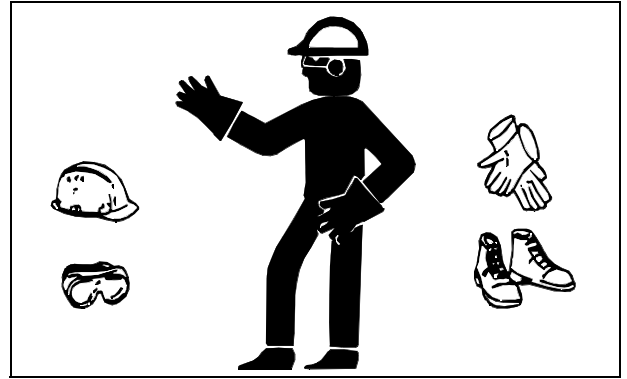

- Wear close fitting clothing and safety equipment appropriate for the job.
- Always wear safety goggles or safety glasses with side shields when operating the mower.
- Wear a suitable protective device such as earplugs. Loud noise can cause impairment or loss of hearing.
- Do not wear radio or music headphones. Safe service and operation requires your full attention.

## Driving Safely on Public Roads

Avoid personal injury or death resulting from a collision with another vehicle on public roads:

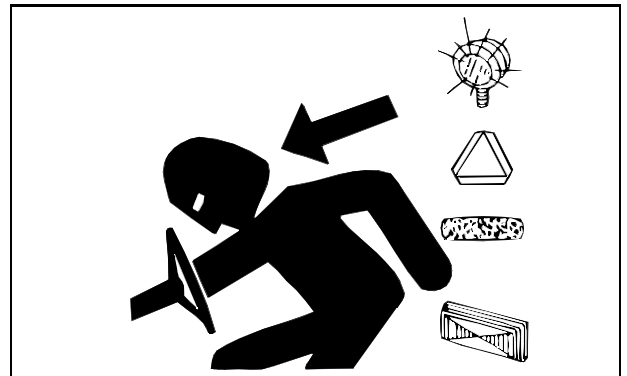

- Use safety lights and devices. Slow moving machines when driven on public roads are hard to see, especially at night.
- Whenever driving on public roads, use flashing warning lights and turn signals according to local regulations. Extra flashing warning lights may need to be installed.

# SAFETY

---

## Practice Safe Maintenance



- Understand service procedure before doing work. Keep area clean and dry.
- Never lubricate, service, or adjust machine while it is moving. Keep safety devices in place and in working condition. Keep hardware tight.
- Keep hands, feet, clothing, jewelry, and long hair away from any moving parts, to prevent them from getting caught.
- Lower attachments to the ground before servicing machine. Disengage all power and stop the engine. Lock park brake and remove the key. Let machine cool.
- Disconnect battery or remove spark plug wire before making any repairs.
- Before servicing the machine, carefully release pressure from any components with stored energy, such as hydraulic components.
- Keep all nuts and bolts tightened, especially blade attachment bolts.
- Securely support any machine elements that must be raised for service work.
- Never run engine unless park brake is locked.
- Keep all parts in good condition and properly installed. Fix damage immediately. Replace worn or broken parts. Replace all worn or damaged safety and instruction decals.
- To prevent fires, remove any buildup of grease, oil, or debris from the machine, especially the engine compartment.
- Charge batteries in an open, well-ventilated area, away from sparks. Unplug battery charger before connecting or disconnecting from the battery. Use insulated tools.
- Do not modify machine or safety devices. Unauthorized modifications may impair its function and safety.
- Do not wear radio or music headphones while servicing the machine. Safe service requires your full attention.

## Prevent Fires

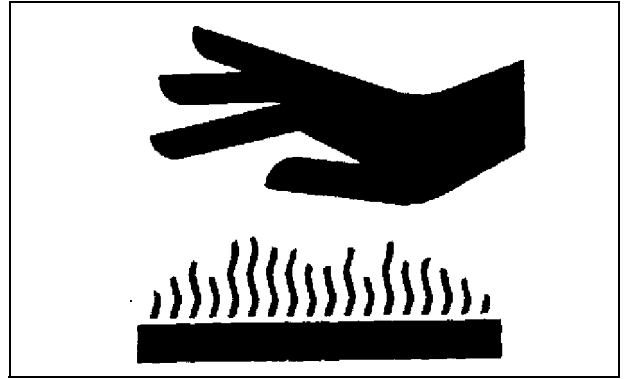

- Never remove fuel cap, or add fuel with engine running or hot. Allow engine to cool for several minutes.
- Never store equipment with fuel in the tank inside a building where fumes may reach an open flame or spark.
- Allow engine to cool before storing in any enclosure.
- To reduce fire hazard, keep engine free of grass, leaves, or excessive grease.

# SAFETY

## Tire Safety

Explosive separation of a tire and rim parts can cause serious injury or death:

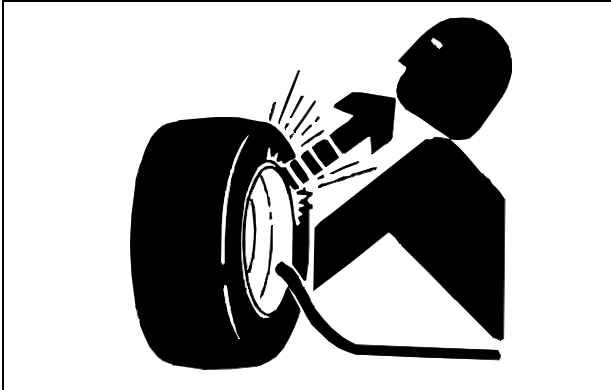

- Do not attempt to mount a tire without the proper equipment and experience to perform the job.
- Always maintain the correct tire pressure. Do not inflate the tires above the recommended pressure. Never weld or heat a wheel and tire assembly. The heat can cause an increase in air pressure resulting in a tire explosion. Welding can structurally weaken or deform the wheel.
- When inflating tires, use a clip-on chuck and extension hose long enough to allow you to stand to one side and NOT in front of or over the tire assembly.
- Check tires for low pressure, cuts, bubbles, damaged rims or missing lug bolts and nuts.

## Handling Fuel Safely

**Fuel and fuel vapors are highly flammable:**



- Do not refuel machine while you smoke, when machine is near an open flame or sparks, or when engine is running. stop engine and allow to cool before filling.
- Never remove the fuel cap or add fuel with the engine

running.

- Never fill fuel tank or drain fuel from a machine in an enclosed area. Fill fuel tank outdoors.
- Prevent fires. Clean up spilled fuel immediately.
- Do not store machine with fuel in tank in a building where fumes may reach an open flame or spark.
- Prevent fire and explosion caused by static electric discharge. Use only non-metal, portable fuel containers approved by the Underwriter's Laboratory (U.L.) or the American Society for Testing & Materials (ASTM). If using a funnel, make sure it is plastic and has no screen or filter.

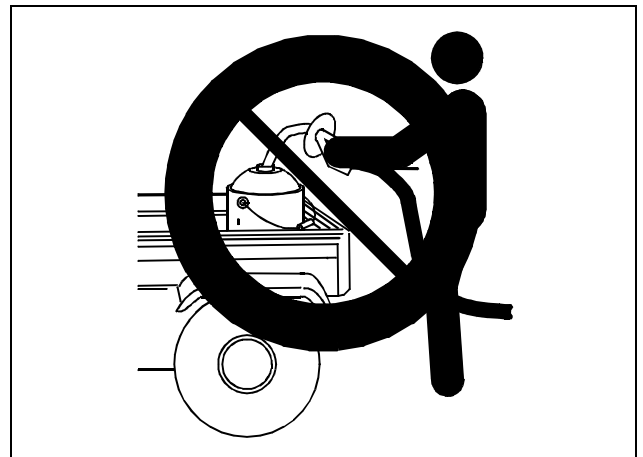

- Static electric discharge can ignite gasoline vapors in an ungrounded fuel container. Remove the fuel container from the bed of a vehicle or the trunk of a car and place on the ground away from the vehicle before filling. Keep nozzle in contact with container opening while filling.
- When practical, remove equipment from trailers or truck beds and refuel them on the ground. If this is not possible, use a portable, plastic fuel container to refuel equipment on a truck bed or trailer.
- For gasoline engines, do not use gas with methanol. Methanol is harmful to your health and to the environment.

# SAFETY

---

## Handling Waste Product and Chemicals

Waste products, such as, used oil, fuel, coolant, brake fluid, and batteries, can harm the environment and people:

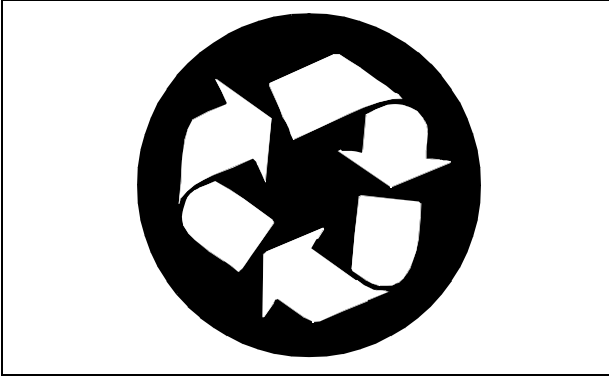

- DO NOT use beverage containers for waste fluids - someone may drink from them.
- See your local Recycling Center or John Deere dealer to learn how to recycle or get rid of waste products.

within a few hours or gangrene may result. Doctors unfamiliar with this type of injury should reference a knowledgeable medical source. Such information is available from Deere & Company Medical Department in Moline, Illinois, U.S.A. Information may be obtained in the United States and Canada only by calling 1-800-822-8262.

## Avoid High Pressure Fluids



- Hydraulic hoses and lines can fail due to physical damage, kinks, age, and exposure. Check hoses and lines regularly. Replace damaged hoses and lines.
- Hydraulic fluid connections can loosen due to physical damage and vibration. Check connections regularly. Tighten loose connections.
- Escaping fluid under pressure can penetrate the skin causing serious injury. Avoid the hazard by relieving pressure before disconnecting hydraulic or other lines. Tighten all connections before applying pressure.
- Search for leaks with a piece of cardboard. Protect hands and body from high pressure fluids.
- If an accident occurs, see a doctor immediately. Any fluid injected into the skin must be surgically removed

# OPERATING

## Daily Operating Checklist

- Test safety systems.
- Check tire pressure.
- Check fuel level.
- Check engine oil level.
- Check transmission oil level.
- Check coolant level on liquid cooled engine.
- Remove grass and debris from machine.
- Clean air intake screen.
- Check area below machine for leaks.

- C - Left Turn Brake Pedal
- D - Right Turn Brake Pedal
- E - Selective Control Valve (SCV) Lever
- F - Hazard/Warning Light Switch
- G - Rockshaft Adjustable Depth Stop Knob
- H - Rockshaft Control Lever
- I - Two Speed Rear PTO Lever
- J - Seat Belt
- K - Creeper Gear Lever
- L - MFWD Control Handle
- M - Park Brake Lever
- N - Transmission Range Shift Lever
- O - Transmission Gear Shift Lever

## Avoid Damage to Plastic and Painted Surfaces

- Do not wipe plastic parts unless rinsed first.
- Insect repellent spray may damage plastic and painted surfaces. Do not spray insect repellent near machine.
- Be careful not to spill fuel on machine. Fuel may damage surface. Wipe up spilled fuel immediately.

## Operator Station Controls

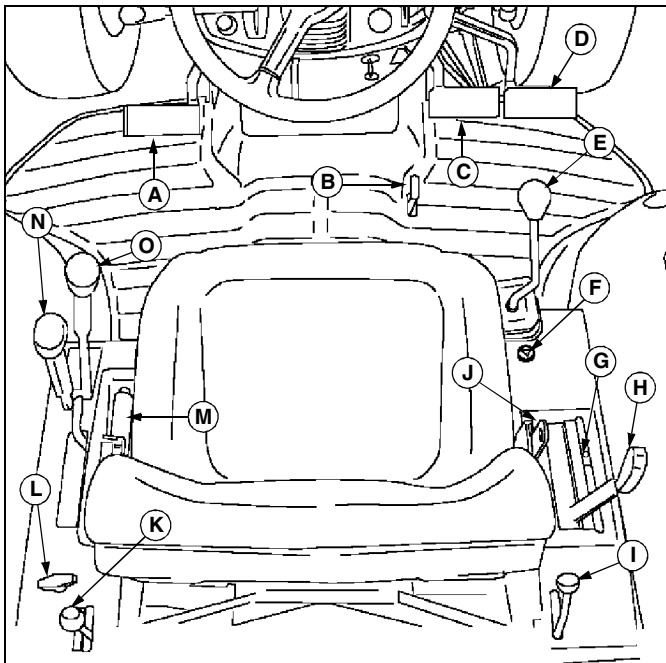

Picture Note: PowrReverser Model

- A - Clutch Pedal
- B - Engine Speed Foot Throttle

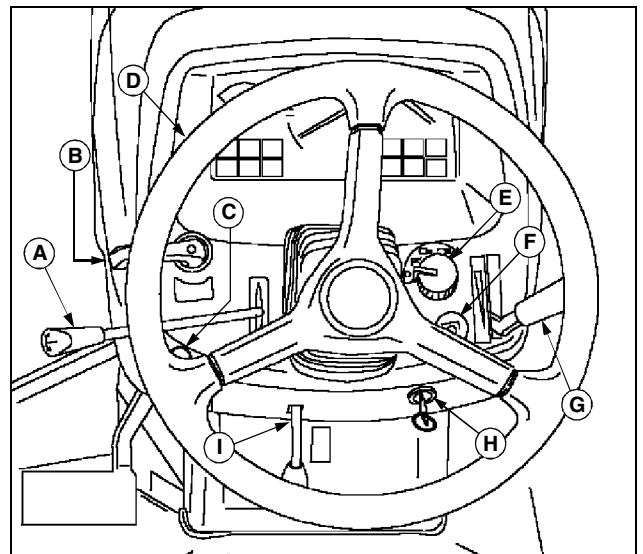

Picture Note: PowrReverser Model

- A - Reverser Lever (PowrReverser Models)
- B - Turn Signal Lever
- C - Horn Button
- D - Steering Wheel
- E - Light Control Switch
- F - PTO Control Knob
- G - Engine Speed Hand Throttle
- H - Ignition Key Switch
- I - Tilt Steering Control Lever

# OPERATING

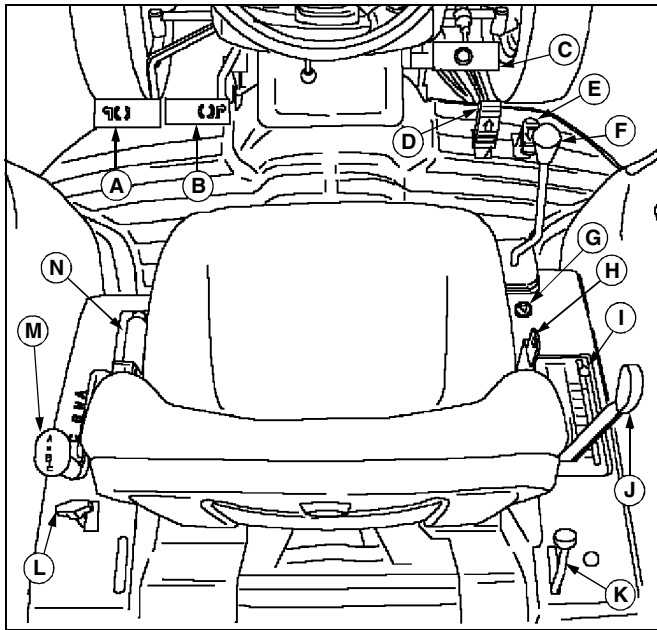

**Picture Note: Hydrostatic Model**

- A - Left Turn Brake Pedal
- B - Right Turn Brake Pedal
- C - Master Brake Pedal
- D - Forward Travel Pedal
- E - Reverse Travel Pedal
- F - Selective Control Valve (SCV) Lever
- G - Hazard/Warning Light Switch
- H - Seat Belt
- I - Rockshaft Adjustable Depth Stop Knob
- J - Rockshaft Control Lever
- K - Two Speed Rear PTO Lever
- L - MFWD Control Handle
- M - Transmission Range Shift Lever
- N - Park Brake Lever

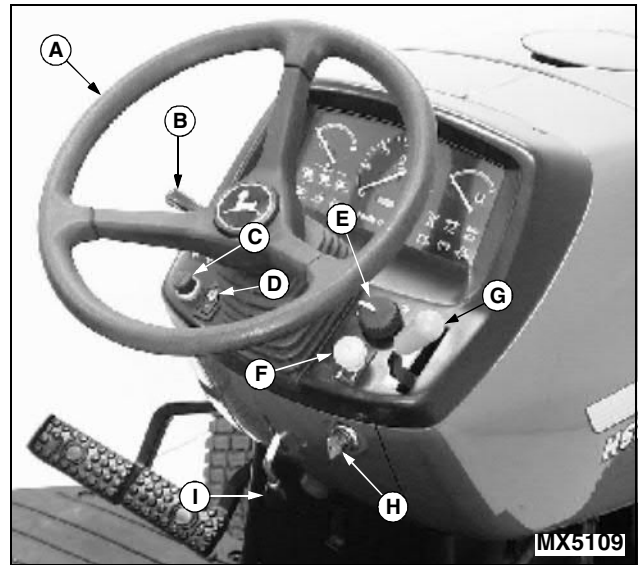

**Picture Note: Hydrostatic Model**

- A - Steering Wheel
- B - Turn Signal Lever
- C - Horn Button
- D - Cruise Control Switch
- E - Light Control Switch
- F - PTO Control Knob
- G - Engine Speed Hand Throttle
- H - Ignition Key Switch
- I - Tilt Steering Control Lever

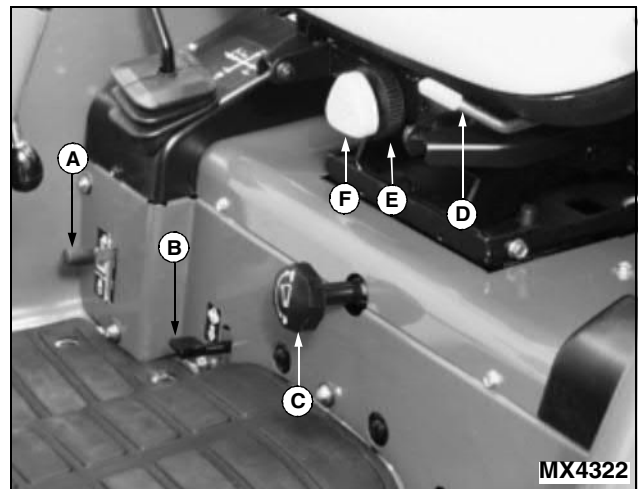

- A - Selective Control Valve (SCV) Lock Lever
- B - Differential Lock Lever
- C - Rockshaft Rate-of-Drop Control Knob
- D - Operator Seat Adjustment Lever
- E - Operator Seat Height Adjustment Knob
- F - Operator Seat Suspension Adjustment Knob

# OPERATING

## 3-Point Hitch

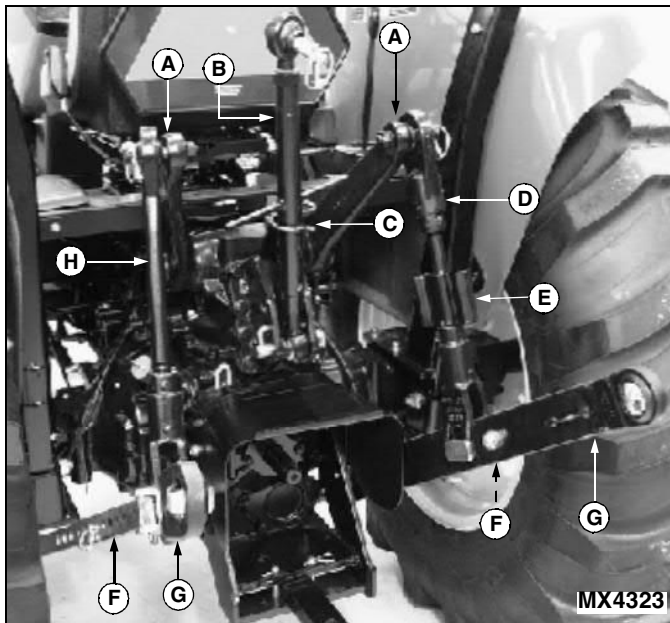

- A - Lift Arms
- B - Center Link
- C - Center Link Storage Hook
- D - Adjustable Lift Link
- E - Lift Link Turn Handle
- F - Sway Link
- G - Draft Link
- H - Non-Adjustable Lift Link

- F - Mid PTO Engagement Light
- G - Front PTO Engagement Light
- H - Tractor Bulb Integrity Light
- I - 1st Wagon Bulb Integrity Light
- J - 2nd Wagon Bulb Integrity Light
- K - Rear PTO Engagement Light-540 RPM
- L - Cruise Control Indicator Light (Operational on Hydrostatic Models Only)
- M - Cold Start Indicator Light
- N - Hour Meter
- O - Alternator/Battery Charging Light
- P - Park Brake Light
- Q - Oil Pressure Light

## Hood Controls

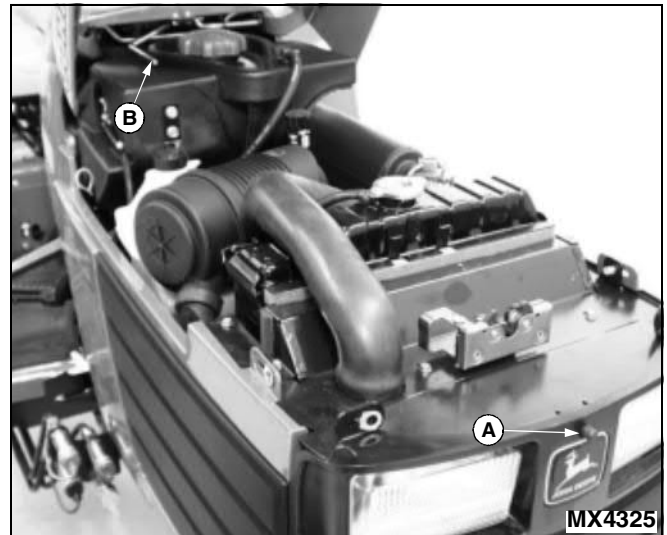

- A - Hood Release Button
- B - Hood Support Latch

## Instrument Panel

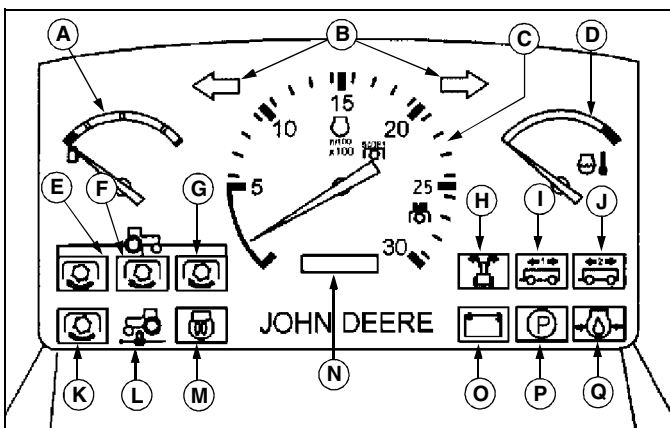

- A - Fuel Gauge
- B - Turn Signal/ Warning Flasher Lights
- C - Tachometer
- D - Engine Coolant Temperature Gauge
- E - Rear PTO Engagement Light-750 RPM

# OPERATING

## Cab Headliner Controls

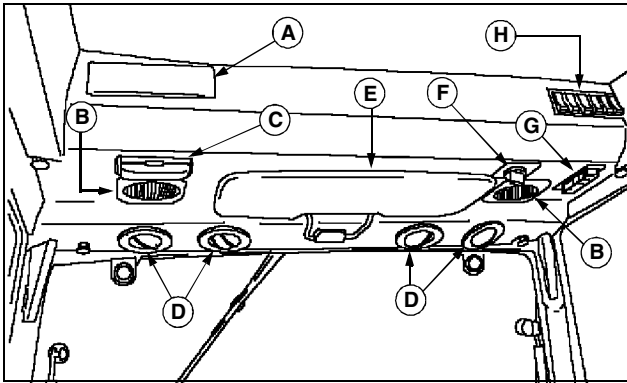

- A - Radio (Option)
- B - Radio Speakers (Option)
- C - Dome Light
- D - Air Louvers
- E - Sun Visor
- F - Temperature Control Knob
- G - Fuse Block
- H - Switch Control Panel

## Radio and Speakers

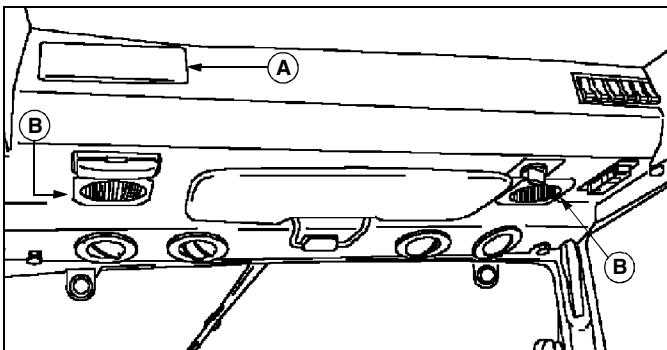

Removable panels are provided to allow installation of and optional radio (A) and two stereo speakers (B). See your John Deere dealer for radio and speaker installation.

## Dome Light

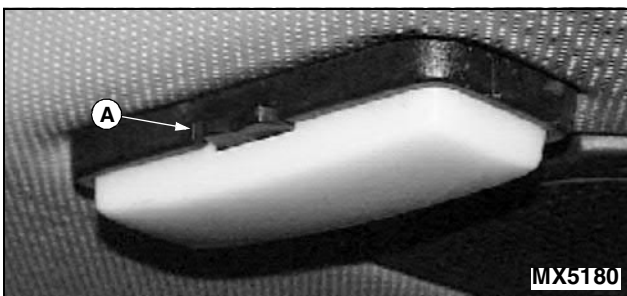

**NOTE:** Dome light can be operated with the key switch in the RUN position.

- Move switch (A) left or right to turn the dome light on.
- Move switch (A) to the centered position to turn the dome light off.

## Air Louvers

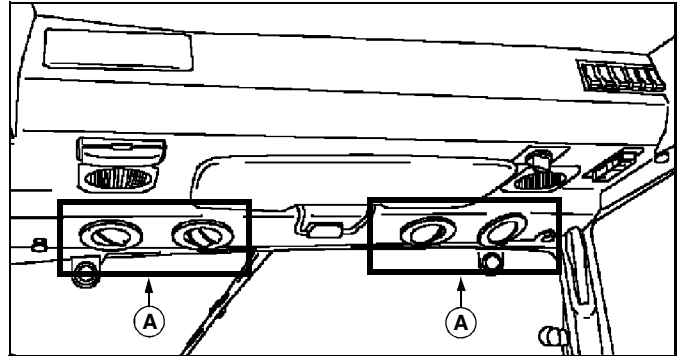

Four adjustable air louvers (A) are installed in the cab headliner. The air louvers can be completely opened or closed and can be rotated 360 degrees to direct air flow. Air volume is controlled by the fan switch and temperature is controlled by using the temperature control knob. Adjust each air louver to a desirable operating position.

## Temperature Control Knob

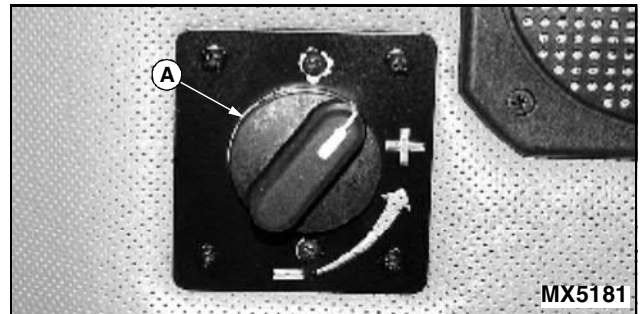

Temperature control knob (A) controls the operation of the heater temperature control. Use the temperature control knob and the fan switch to regulate the temperature inside the cab.

- Turning the temperature control knob completely counterclockwise will provide the greatest amount of heat.
- Turning the temperature control knob completely clockwise will provide no heat.
- Adjust the temperature control knob to a desirable operating position.



**Suggest:**

**If the above button click is invalid.**

**Please download this document**

**first, and then click the above link**

**to download the complete manual.**

**Thank you so much for reading**

# OPERATING

## Switch Control Panel

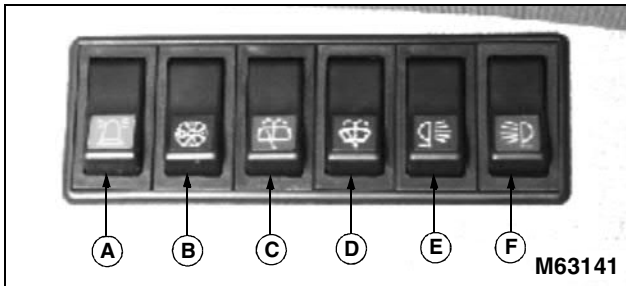

- A - Beacon Light Switch (Option)**
- B - Fan Switch**
- C - Rear Wiper/Washer Switch**
- D - Front Wiper/Washer Switch**
- E - Rear Work Lights**
- F - Front Work Lights**

**Beacon light switch (A)** controls the operation of the optional warning beacon light mounted on the cab roof.

- Depress top of switch to turn light off.
- Depress bottom of switch to turn light on.

**Fan speed switch (B)** controls the operating speed of the cab fan.

- Depress top of switch to turn fan off.
- Move switch to the centered position for medium fan speed operation.
- Depress bottom of switch for high fan speed operation.

**Rear wiper/washer switch (C)** controls the operation of the rear windshield wiper motor and washer fluid pump.

- Depress top of switch to turn wiper off.
- Move switch to the centered position to turn wiper on.
- Depress bottom of switch to activate washer pump.

**Front wiper/washer switch (D)** controls the operation of the front windshield wiper motor and washer fluid pump.

- Depress top of switch to turn wiper off.
- Move switch to the centered position to turn wiper on.
- Depress bottom of switch to activate washer pump.

**Rear work light switch (E)** controls the operation of the work lights mounted in the roof at the rear of the cab.

- Depress top of switch to turn lights off.
- Depress bottom of switch to turn lights on.

**Front work light switch (F)** controls the operation of the work lights mounted in the roof at the front of the cab.

- Depress top of switch to turn lights off.
- Depress bottom of switch to turn lights on.

## Adjusting Cab Mirrors

**IMPORTANT: Avoid damage! Cab mirrors must be adjusted to avoid contact with doors when opened.**

**NOTE: Mirrors have a swing-away feature that allows mirror arms to pivot if contact is made with protruding object.**

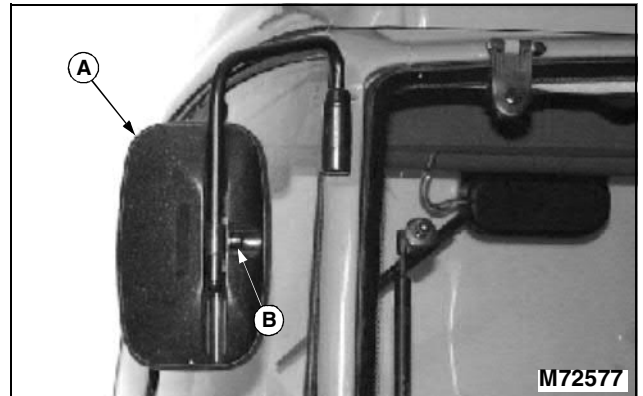

1. Pivot each mirror (A) to a desirable operating position. The line of sight to the rear and sides of the tractor should be clearly visible from the operators seat.
2. Loosen clamp (B) to raise or lower mirror on arm.

## Operating Cab Door Handles

### Opening Cab Doors

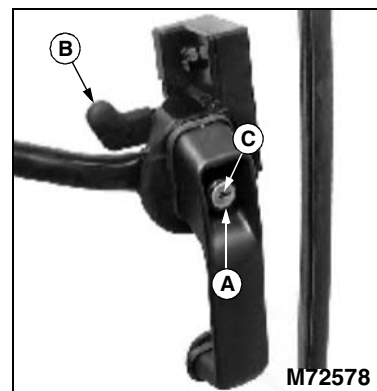

1. Depress door handle button (A) to open cab door from outside the tractor.
2. Push lever (B) down to open cab door from inside the tractor.

### Locking Cab Doors

**NOTE: Each cab door can be locked from outside the tractor. Use key set provided to prevent unauthorized entry.**

**<https://www.ebooklibonline.com>**

Hello dear friend!

Thank you very much for reading.

Enter the link into your browser.

The full manual is available for immediate download.

**<https://www.ebooklibonline.com>**