

4420 Combine



JOHN DEERE

OPERATORS MANUAL

4420
Combine

OMH120063 Issue C5 English

John Deere Harvester Works
OMH120063 Issue C5

LITHO IN U.S.A.
ENGLISH



INTRODUCTION



This safety alert symbol identifies important safety messages in this manual. When you see this symbol, be alert to the possibility of personal injury and carefully read the message that follows.

Your operator's manual contains SI metric equivalents which follow immediately after the U.S. customary units of measure.

"Right-hand" and "left-hand" sides are determined by facing in the direction the combine will travel when in use.

Record identification number(s) in space provided in Specifications. Accurately record "ALL" of the letters and numbers in case a computer is used to trace a stolen machine or for ordering parts from a dealer. Make an additional copy of the numbers and file it in a safe place.

The warranty on this combine appears on your copy of the purchase order which you should have received from your dealer when making your purchase. This warranty provides you the assurance that John Deere will back its products where defects appear within the warranty period. In some circumstances, John Deere also provides field improvements, often without charge to the customer, even if the product is out of warranty.

The tire manufacturer's warranty supplied with your machine may not apply outside the U.S. and Canada.

Warranty and field improvements are a part of John Deere's product support program for customers who operate and maintain their equipment as described in this manual. Should the equipment be abused or modified to change its performance beyond the original factory specifications, the warranty will become void and field improvements may be denied. Setting fuel delivery above specifications or otherwise overpowering machines will result in such action.

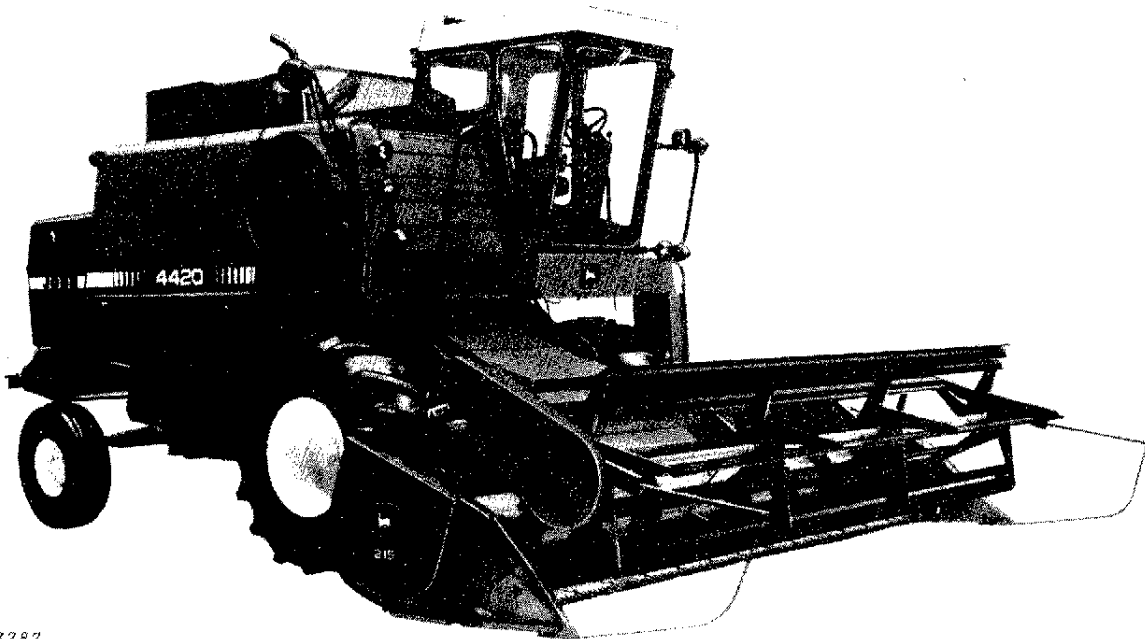

H33787

H33787



Contents

	Page
Introduction	Inside
Contents	1
Safety	2-5
Operator's Station	6-13
Engine Break-In	14-16
Prestarting Checks	15-16
Operating the Engine	17-21
Driving the Combine	22-23
Transporting	24
Lighting and Signals	25-28
Fuels and Lubricants	29-32
Lubrication and Maintenance	33-43
Fundamentals of Combine Harvesting	44-64
Headers	65-67
Feeder House	68-93
Separator	94-138
Grain Tank and Unloading Auger	139-145
Engine Service	146-159
Electrical System	160-165
Monitors	166-167
Hydraulic System	168-171
Power Train	172-184
Air Conditioner and Heater	185-188
Trouble Shooting	189-206
Storage	207-211
Crime Prevention Tips	211A-211C
Specifications	212-216
Index	217-219

<https://www.ebooklibonline.com>

Hello dear friend!

Thank you very much for reading.

Enter the link into your browser.

The full manual is available for immediate download.

<https://www.ebooklibonline.com>



Safety

SAFETY DECALS



H22428N



CAUTION, WARNING or DANGER: Decals with these headings and symbol indicate the possibility of personal injury.

IMPORTANT: Decals with this heading indicate the possibility of damage to the machine.

Decals are located in areas where they apply.

H29488

AVOID CONTACT WITH MOVING PARTS

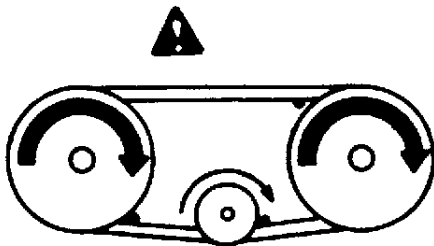

H3688C

Keep guards and shields in place at all times while operating the combine. Always disengage separator and shut off engine before removing guards or shields.

Unauthorized modifications to the machine may impair the function and or safety and affect machine life.

Keep hands, feet, and clothing away from power-driven parts.

Never clean, lubricate, or adjust the combine when it is running.

Sound horn. Everyone must be clear before starting engine or running combine.

Never attempt to clear obstructions off the header unless the separator is disengaged and the engine is shut off.

LEAVING COMBINE UNATTENDED

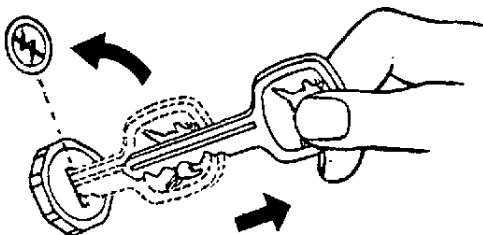

H37524

Before leaving the combine unattended, turn off engine and remove keys, support the header with either the hydraulic cylinder safety stop, or lower it to the ground. The gearshift lever must be in neutral and the parking brake engaged.

SERVICE TIRES

Failure to follow proper procedures when mounting a tire on a wheel or rim can produce an explosion which may result in serious injury or death. Do not attempt to mount a tire unless you have the proper equipment and experience to perform the job. Have it done by your John Deere dealer or a qualified tire repair service.

When sealing tire beads on rims, never exceed 35 psi (2.40 kPa) (2.4 bar) or maximum inflation pressures specified by tire manufacturers for mounting tires. Inflation beyond this maximum pressure may break the bead, or even the rim, with dangerous explosive force. If both beads are not seated when the maximum recommended pressure is reached, deflate, reposition tire, re-lubricate bead, and reinflate.

Detailed tire mounting instructions, including necessary safety precautions, are contained in John Deere Fundamentals of Service (FOS) Manual 55, Tires and Tracks, available through your John Deere dealer. Such information is also available from the Rubber Manufacturers Association and from tire manufacturers.

- A—Use a safety cage if available.
- B—Do not stand over tire. Use a clip-on chuck and extension hose.

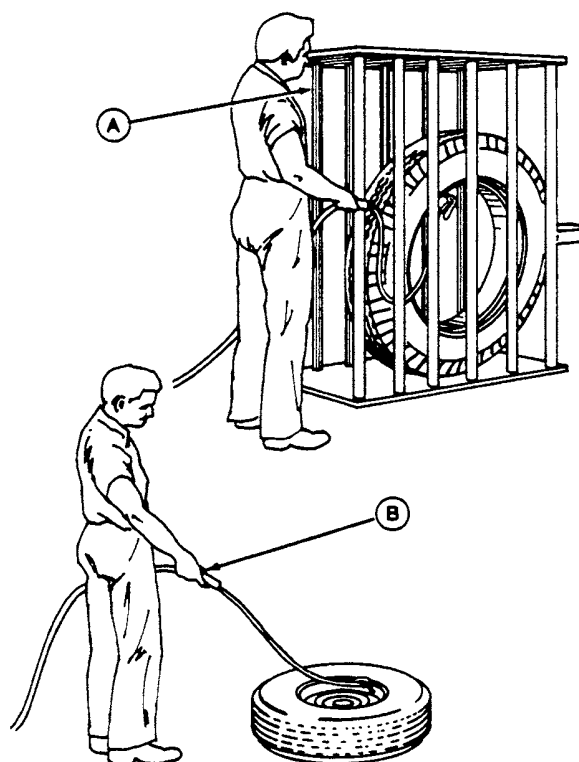

T5-0123

WASHING FRONT CAB WINDOW

To wash front window of cab, stand on ground and use a long handled squeegee or mop to reach top of window. Do not stand on feeder house or header top beam, as this could result in a fall.

SERVICING DRIVES AND DRIVE RELATED AREAS

Shut off engine and remove key before servicing combine in either a belt driven area or any area receiving power from a belt drive. Some drives, due to their clutching and declutching characteristics, can be engaged when the engine is running by the applying or removing of outside forces.

Replace any shields that were removed.

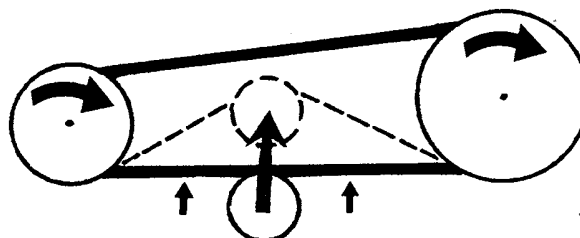

H37564

OPERATE SAFELY

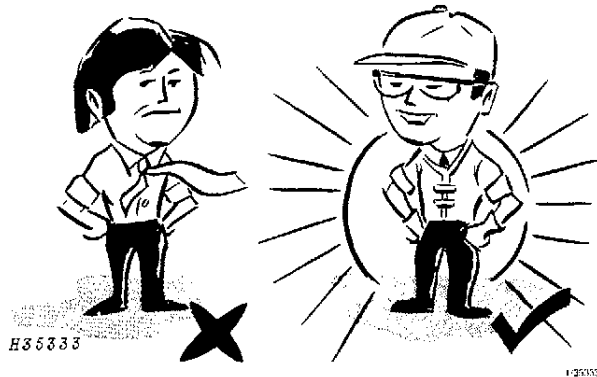

Clothing be worn by operator must be fairly tight and belted. Loose jackets, shirts, or sleeves must never be worn.

Disengage separator lever, move shift lever to neutral and sound horn before starting.

Be careful when operating on hillsides so the combine will not tip.

Always keep the combine in gear when going down hills.

Use right-hand cab door to get to engine compartment or feeder house areas. Never climb to these areas from the ground.

Do not ride or attempt to climb rear ladder while combine is moving.

When operating combine in extremely muddy conditions, swing ladder up to prevent it from being bent when backing up.

The radio antenna must be bent forward and secured with clip any time the combine may come into contact with a high voltage wire or when combine is transported by truck or rail.

BATTERIES



Batteries generate explosive gases. Keep sparks, flames, burning cigarettes, or other ignition sources away at all times. Always shield eyes when working near batteries. Always wear safety glasses.

Do not connect or disconnect live circuits.

Turn off charger before attaching or removing a lead from the battery.

Ventilate the area when charging.

NOISE

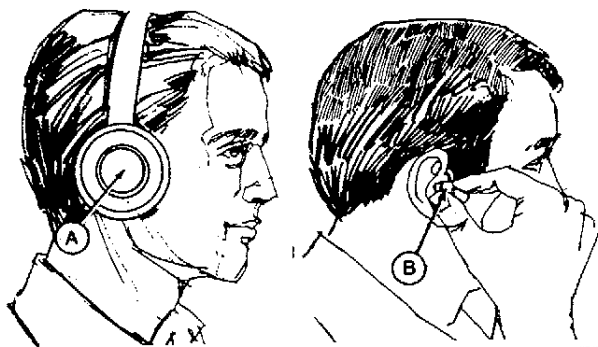

Prolonged exposure to loud noise can cause impairment or loss of hearing.

Wear a suitable hearing protective device such as earmuffs (A) or earplugs (B) to protect against objectionable or uncomfortable loud noises.

A—Earmuffs
B—Earplugs

AVOID HIGH PRESSURE FLUIDS

Escaping fluid under pressure can penetrate the skin causing serious injury. Relieve pressure before disconnecting hydraulic or other lines. Tighten all connections before applying pressure. Keep hands and body away from pin holes and nozzles which eject fluids under high pressure. Use a piece of cardboard or paper to search for leaks. Do not use your hand.

If ANY fluid is injected into the skin, it must be surgically removed within a few hours by a doctor familiar with this type injury or gangrene may result.

Cracking hydraulic line fittings to lower the feeder house will result in an instantaneous dropping of feeder house or feeder house and header.



X9811

FIRE EXTINGUISHER

Have a multipurpose dry chemical fire extinguisher filled and handy. Know how to use it.

DO NOT refuel with the engine running.

DO NOT smoke or use a lantern when refueling.

The part number of the extinguisher is AT62018. See page 12 for installation instructions.



RW2389

TRANSPORT SAFELY

Never ride or allow anyone on the operator's platform.

Be extra careful when transporting the combine in hilly country. Never transport with grain in tank and always lock brake pedals together.

When transporting the combine on a road or highway, use accessory lights and devices for adequate warning to the operators of other vehicles. In this regard, check local governmental regulations. Always check width laws.

The radio antenna must be bent forward and secured with clip when transporting the combine. This prevents the antenna coming into contact with a high voltage wire.

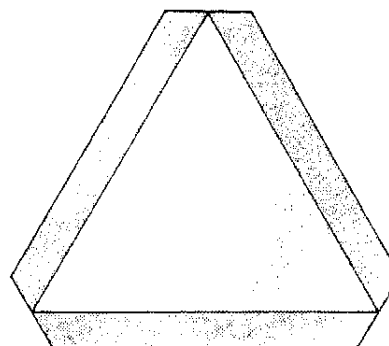

H35338

H35338



Operator's Station

INSTRUMENTS AND CONTROLS IDENTIFICATION

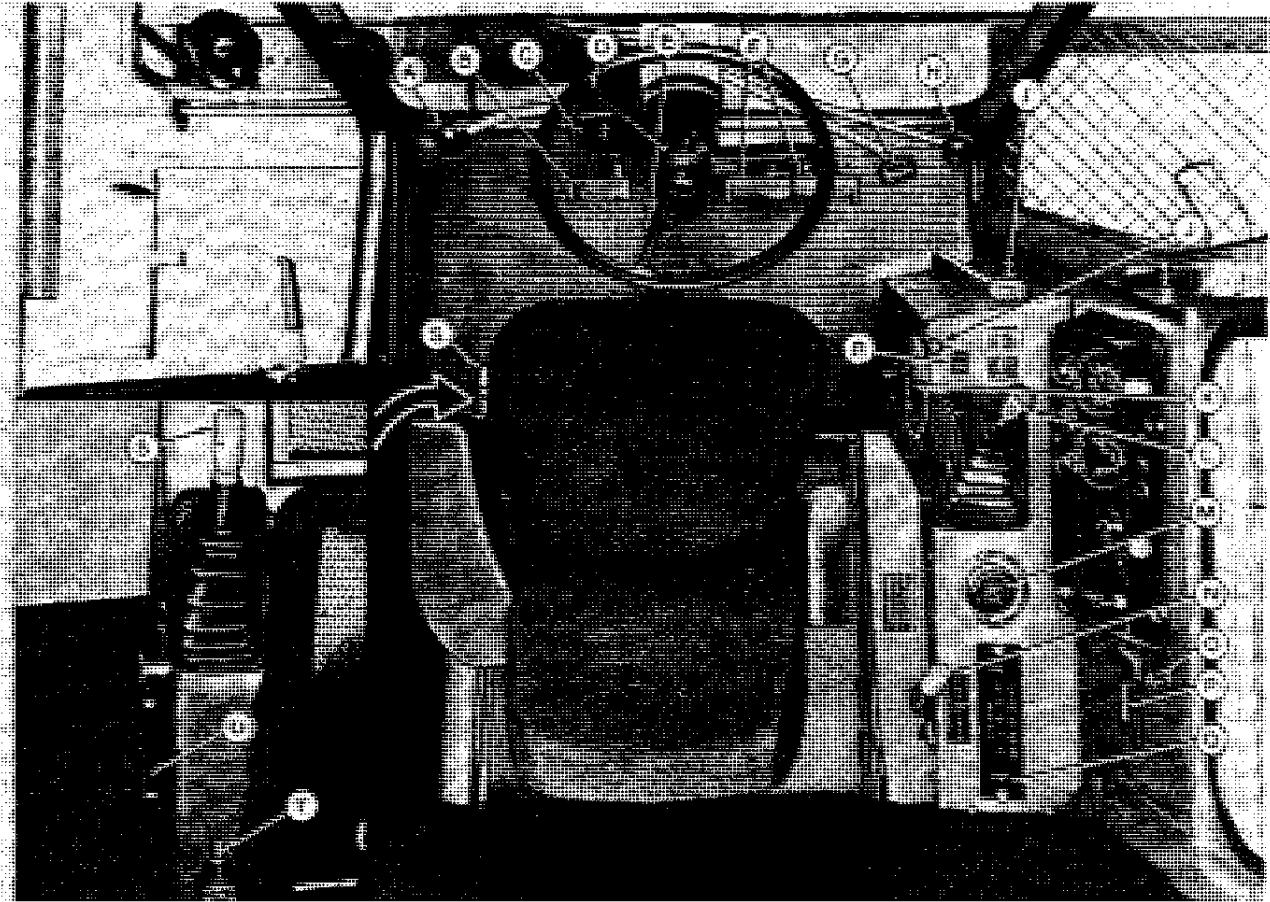

	Page
A—Hydraulic Lift Reel or Variable Speed Feeder House Control	66,68
B—Clutch Pedal	22
C—Turn Signals	23,28
D—Steering Wheel	
E—Steering Column Pedal	13
F—Brake Pedals	22
G—Selective Ground Speed Control	22

	Page
H—Header Lift Control	67
I—Separator Control	94
J—Throttle	13
K—Concave Opening Control	95
L—Gearshift	22
M—Reel Drive or Belt Pickup Drive Control	66
N—Cylinder Speed Control	95
O—Cigarette Lighter	

	Page
P—Ash Tray	
Q—Low Shaft Speed Monitor	166
R—DIAL-A-MATIC® Control Switch (Optional)	67
S—Parking Brake	184
T—Unloading Auger Hydraulic Swing Control Knob	140
U—Grain Tank Unloading Auger Lever	140

H37143

Instrument Panel Controls and Instruments

	Page
A—Engine Tach-Hour Meter	8
B—Header Electromagnetic Clutch Switch	66
C—Cylinder Speed Tachometer	8
D—Parking Brake Indicator Light	9
E—Alternator Indicator Light	9
F—Cold Weather Starting Aid Button	20
G—Horn Button	—
H—Ignition Switch	13
I—Light Switch	26
J—Coolant Temperature Gauge	9
K—Engine Oil Pressure Gauge	9
L—Fuel Gauge	6
M—Dial-A-Matic™ Header Height Switch (Optional)	7,67

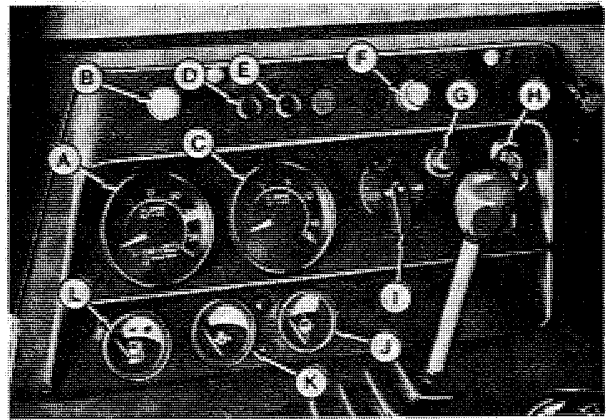

H07147

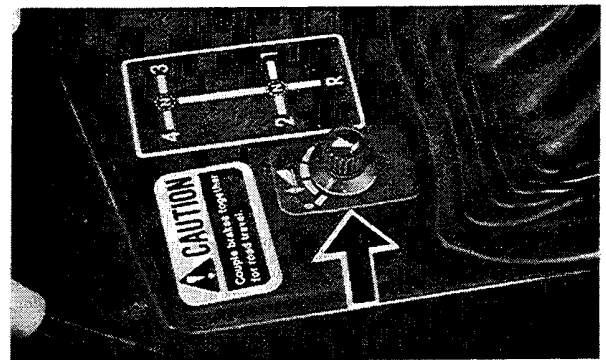

H50202

Operator's Cab Controls

	Page
A—Heater Temperature Control Switch	10
B—Pressurizer Fans Switch	10
C—Air Conditioner Temperature Control Switch	10
D—Windshield Wiper Switch	10

The operator's cab controls are located in the cab headliner. The radio is located in the rear right-hand corner of the cab.

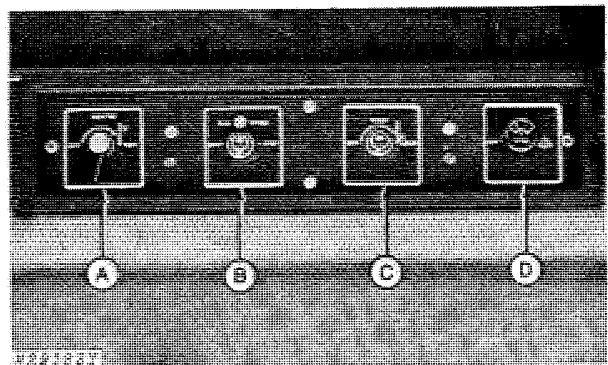

H291827

H291827

INSTRUMENTS

Engine Tach-Hour Meter

The tachometer reads engine rpm by hundreds.

The hour meter shows the accumulated engine service in hours and tenths of hours.

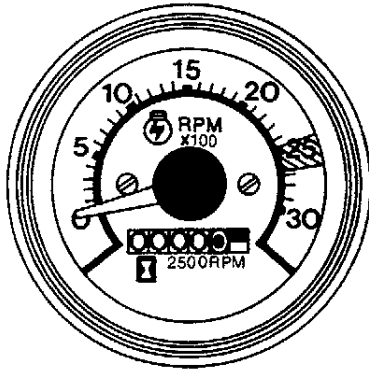

H33749

Cylinder Speed Tachometer

The tachometer reads cylinder rpm by hundreds.

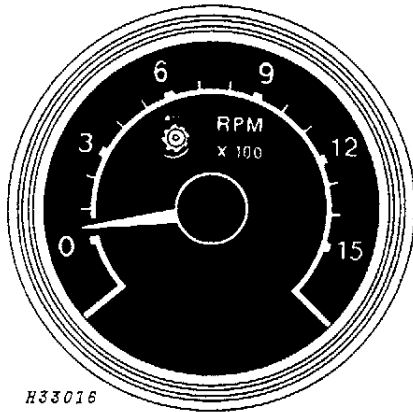

H33016

Fuel Gauge

Stop to refuel before fuel gauge reaches empty mark.
Never allow a diesel engine to run out of fuel.

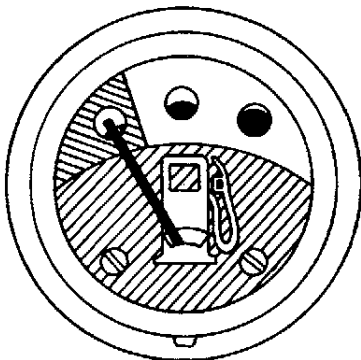

H33751

Engine Oil Pressure Gauge

This gauge indicates pressure in psi.

The normal operating range is 40-60 psi (2.76-4.14 bar)
Gauge needle must be pointing to unlined zone.

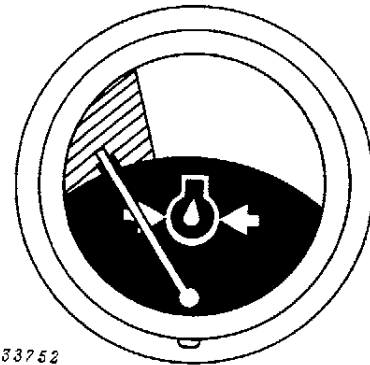

H33752

H33752

Coolant Temperature Gauge

This gauge indicates coolant temperature in cooling system. The white zone on the dial indicates normal operating temperature; red-orange zone indicates above normal operating temperature. If there is a coolant loss or an air lock, the gauge might not show a temperature rise.

IMPORTANT: High cylinder head temperature will sound low note horn as warning even though coolant temperature gauge may not be in red-orange zone. Stop engine and check for cause. This horn warning is added protection in case of sudden coolant loss or air lock.

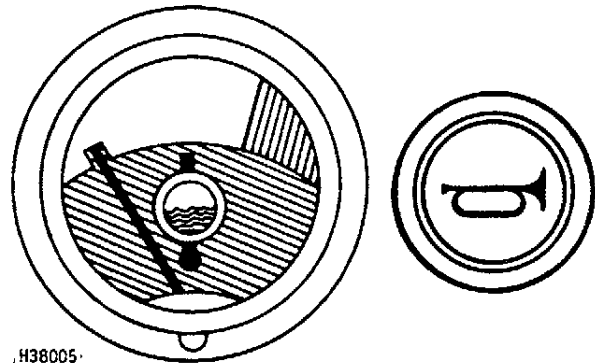

H38005

H38005

Warning Lights

The monitor lights are located on the counsel.

- A—Conveyor Augers
- B—Tailings Auger
- C—Clean Grain Elevator
- D—Straw Walker
- E—Straw Chopper

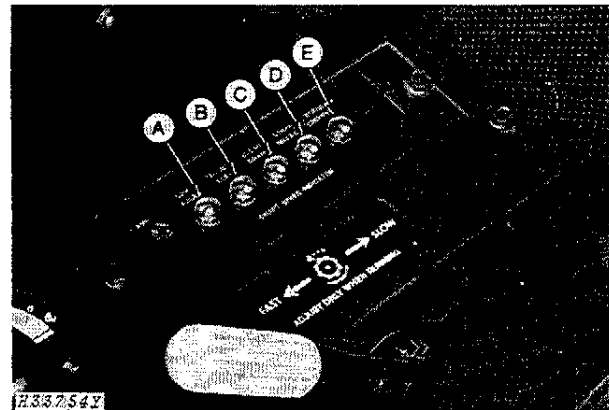

H33754Y

The parking brake light and alternator light are located on the instrument panel.

- F—Parking Brake Indicator Light
- G—Alternator Indicator Light

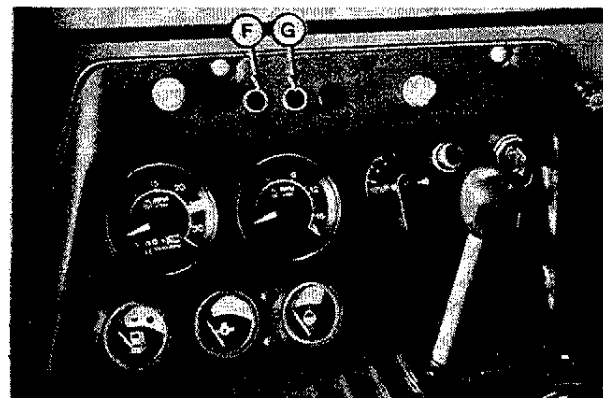

H37174

CONTROLS

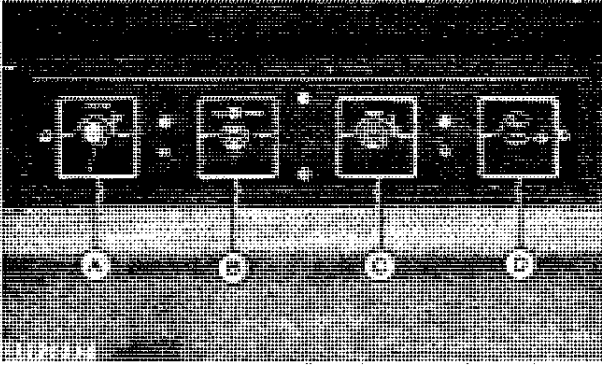

NOTE: Only "comfort" controls are covered here. Driving and harvesting function controls are covered in the applicable sections of this manual.

- A—Heater Temperature Control Switch
- B—Pressurizer Fans Switch
- C—Air Conditioner Temperature Control Switch
- D—Windshield Wiper Switch

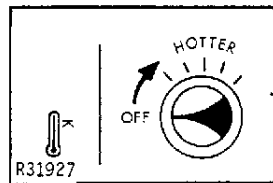

Heater

Control temperature with heater control and pressurizer switch.

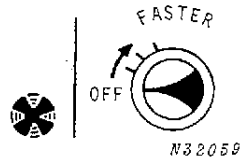

Pressurizer Fan

This switch controls the fan which pressurizes the cab. This is a three-speed switch with the highest speed obtained by turning the switch clockwise as far as it will go.

IMPORTANT: Pressurizer fan must be operating whenever the heater or air conditioner is in use.

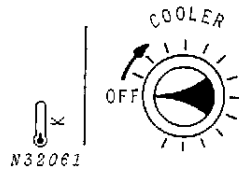

Air Conditioning

Pressurizer fan switch must be turned on before the air conditioning system will operate. Regulate temperature with air conditioning control and pressurizer fan speed.

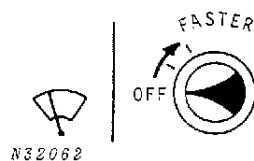

Wiper

The windshield wiper has a two speed switch.

Louvered Air Outlets

Adjust louvers to direct air where needed, such as for defogging windows.

OPERATOR'S SEAT

Personal-Posture Seat

Seat fabric may be vacuumed or brushed with a soft bristle brush to remove loose dirt and dust. Use fabric cleaners to clean normal soilage on fabric. To clean grease and oil stains use solvent-type spot removers.

Use only warm water and mild soap to clean arm rest. Never use solvents.

Adjusting Seat Forward or Rearward

Sit in the seat, push lever (A) forward as far as possible and by using your weight, adjust seat to the desired position. Release lever (A).

Adjusting Seat Up or Down

Remove the four spring locking pins (B). Raise or lower the seat to the desired height. Replace spring locking pins (B).

Raising Seat to Access Position

CAUTION: Engine must be off and key removed.

Loosen wing nuts (C) and move locks (D) to raise seat to access position.

Lift lid with seat and hold open with rod.

CAUTION: Keep hands or fingers from under seat or lid when lowering.

Adjusting Armrest Height

Press armrest button (A), move armrest up or down to the desired position, and release button. Do not sit on armrest.

Adjusting Backrest Angle

To change backrest angle, raise or lower the backrest angle control knob (B).

Adjusting Lumbar Support

Move knob (C) up or down to adjust lumbar support to the desired pressure against your lower back.

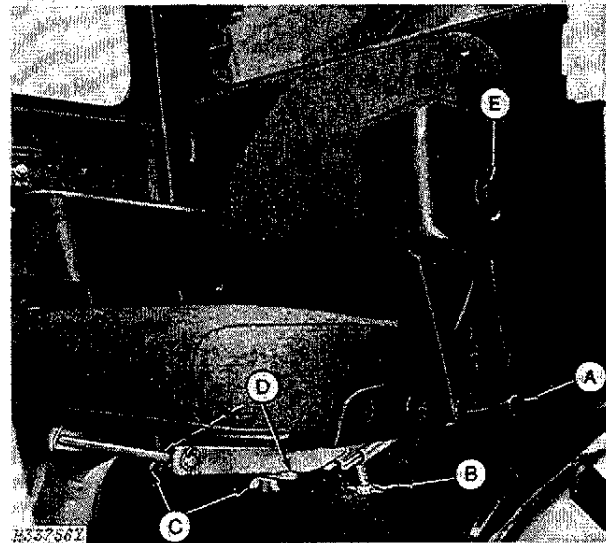

A—Lever
B—Spring Locking Pins
C—Wing Nuts
D—Locks
E—Armrest Release Button

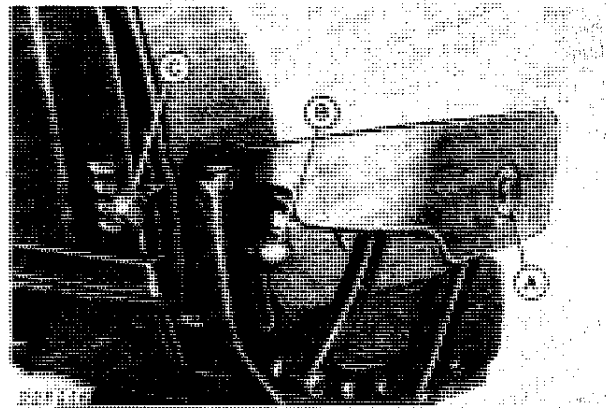

A—Armrest Release Button
B—Backrest Angle Knob
C—Lumbar Support Knob

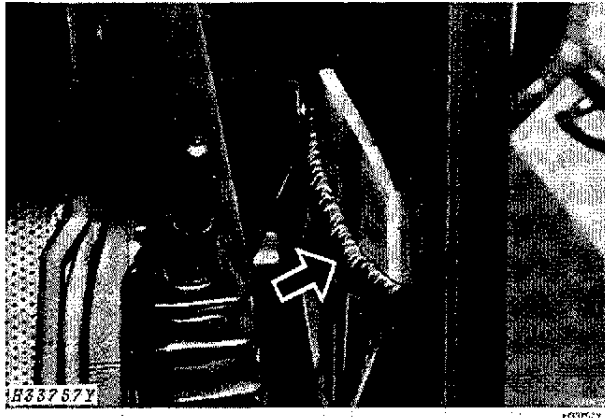

Operator's Manual Storage

A pocket on the left-hand side of the cab is provided to store operator's manual.

FIRE EXTINGUISHER

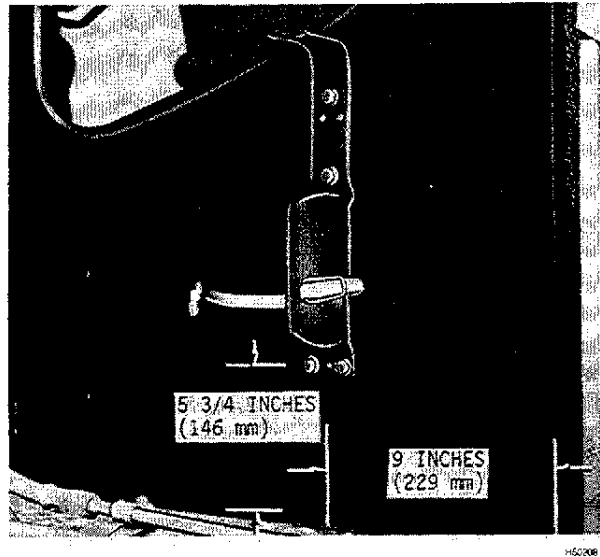

1. Center mounting bracket on cab side panel (in back of door) using dimensions shown.
2. Use bracket as template to mark four holes.
3. Drill four holes with #10 drill bit.
4. Secure bracket with four screws.
5. Install extinguisher and secure with clamp.

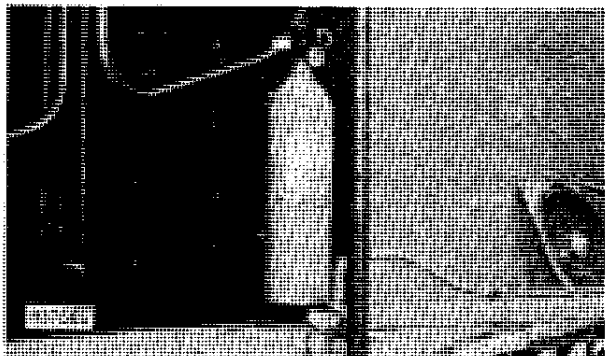

STEERING COLUMN

Step on pedal and move steering column to desired position. Release pedal to lock steering column.

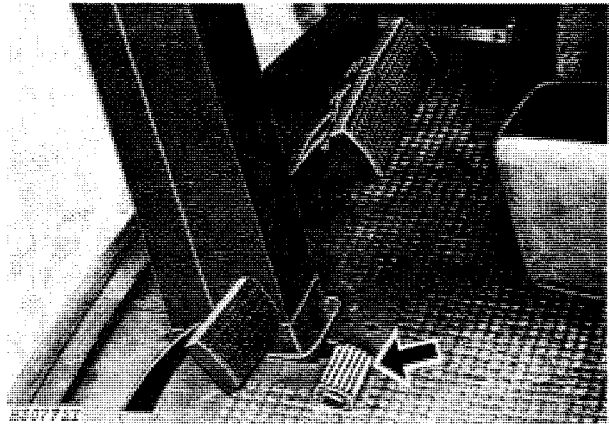

IGNITION SWITCH

CAUTION: Sound horn to clear everyone from combine before starting engine.

Turn the key clockwise from off (A) to the run position (B). Turn the key further clockwise to start position (C).

When released it will return to run position (B).

Turn key counterclockwise from off position (A) to operate accessories (D).

- A—Off Position
- B—Run Position
- C—Start Position
- D—Accessories

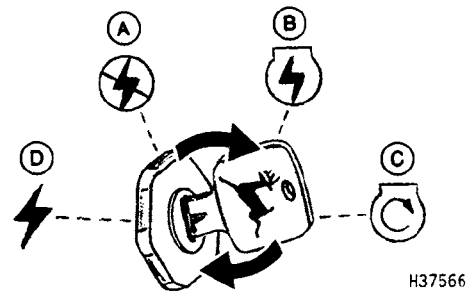

H37566

H37566

THROTTLE

Move throttle all the way forward for normal operation.

Move throttle all the way rearward for slow idle or when starting the engine.

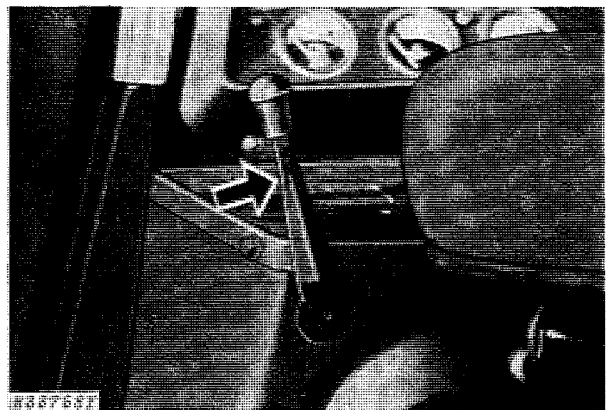

H33758Y



Engine Break-in

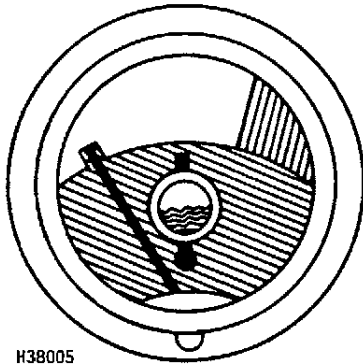

H38005



H38005

Engine Break-in

The engine is ready for normal operation. However, be extra cautious during the first 100 hours.

1. Avoid unnecessary engine idling. If combine will be idle longer than five minutes, stop the engine.
2. Watch coolant temperature gauge closely. If temperature rises to the warning zone, shift to a lower gear or reduce load. Unless temperature quickly drops, stop the engine and determine the cause.

IMPORTANT: High cylinder head temperature will sound low note horn as warning even though coolant temperature gauge may not be in red-orange zone. Stop engine and check for cause. This horn warning is added protection in case of sudden coolant loss or air lock.

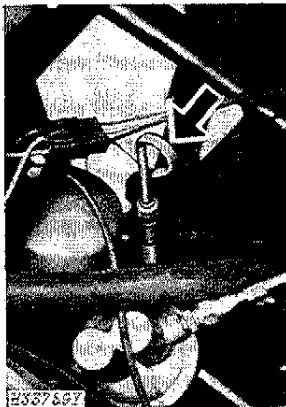

H337897

H33759Y

Engine Oil Dipstick

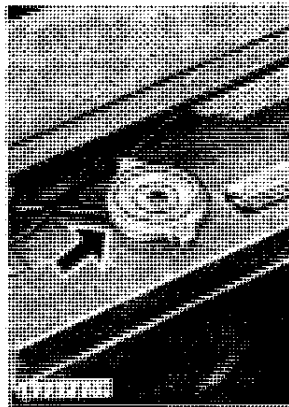

H33760Y

Radiator Cap

3. Check engine oil and coolant levels more frequently. Watch for any signs of leaks.
4. Until you become thoroughly familiar with the sound and feel of your new combine, stay extra attentive and alert.

After 1 Hour of Operation Check Torque on All Wheel Bolts:

Drive Wheels 400 ft-lbs (542 N·m)

Steering Wheels 130 ft-lbs (176 N·m)

IMPORTANT: Wheel bolts must be clean and free of lube before installing. Torque value is for clean dry bolt. Lubricating reduces friction and overloads the bolts.

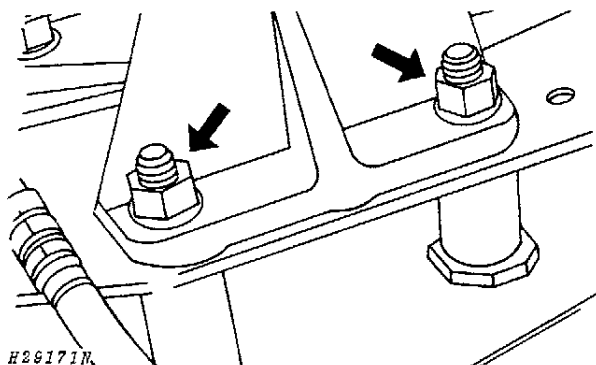

H29171N

H29171N

After 5 Hours of Operation

Check all V-belts for initial stretch. Tighten as necessary. Continue to check V-belts every few hours for the first 50 hours.

Tighten eight 3/4-inch machine bolts, attaching separator uprights to drive wheel axle, to 300 ft-lbs (407 N·m).

After 100 Hours of Operation

Drain crankcase oil, change filter, and refill with Torq-GARD SUPREME® Oil. See lubrication Section. Thereafter, repeat this procedure every 200 hours or once a season, whichever occurs first.

IMPORTANT: If diesel fuel sulfur content exceeds 0.7 percent, change oil every 100 hours.



Prestarting Checks

Before starting the engine for the first time each day:

1. Check engine oil level. Do not operate engine when oil level is below the low mark on the dip stick.

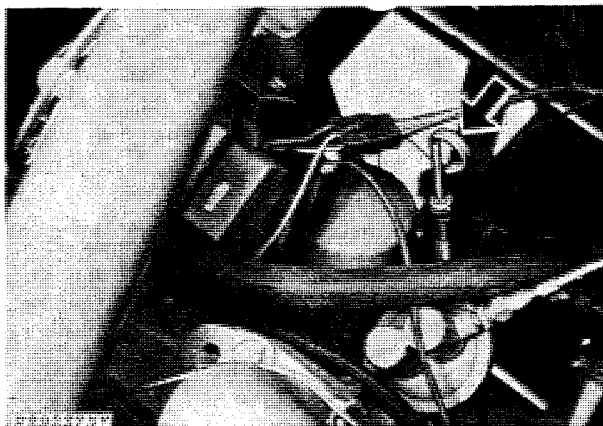

2. Check radiator coolant level. Add coolant until radiator is full and install cap. Fill surge tank to 1-in. (25 mm) from top of neck.

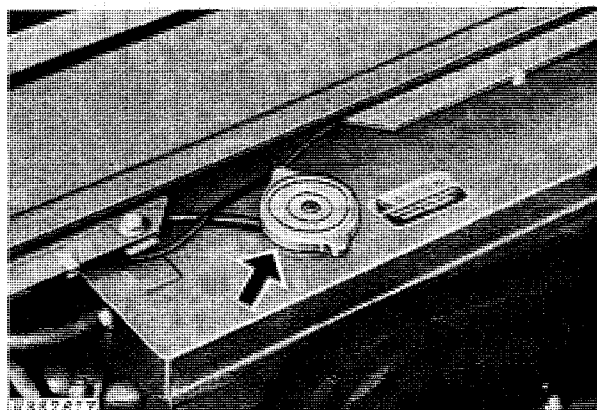

3. Check hydraulic oil level. With header on the ground, oil must be to "FULL" mark on dipstick attached to oil reservoir cap. Do not overfill above "FULL" mark.

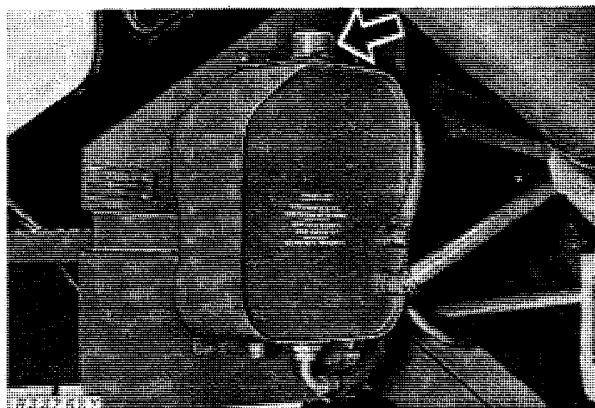



Suggest:

If the above button click is invalid.

Please download this document

first, and then click the above link

to download the complete manual.

Thank you so much for reading

16 *Prestarting Checks*

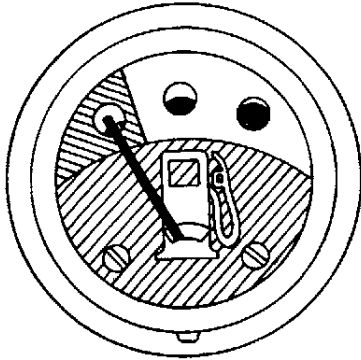

H33751

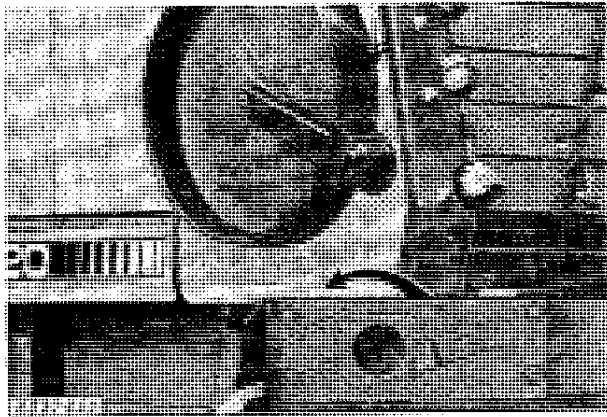

4. Check fuel gauge.

5. Drain any accumulated water out of fuel tank and engine fuel filter.
6. If engine has not been operated for a long time, bleed entire fuel system to remove air bubbles.
7. Be certain combine is properly lubricated.
8. Be certain rotary screen drive is engaged.

IMPORTANT: To prevent breaking drive belt, rotary screen must turn easily and be free of snow and ice, before starting engine.

<https://www.ebooklibonline.com>

Hello dear friend!

Thank you very much for reading.

Enter the link into your browser.

The full manual is available for immediate download.

<https://www.ebooklibonline.com>