

Compact Utility Tractor with Gear Transmission

Model 4100 Serial No. (110001 -)



OPERATOR'S MANUAL

John Deere
Worldwide Commercial And
Consumer Equipment Division
OMM134596 C8

European
Litho in U.S.A.
English

INTRODUCTION

READ THIS MANUAL carefully to learn how to operate and service your machine correctly. Failure to do so could result in personal injury or equipment damage. This manual and safety signs on your machine may also be available in other languages (see your John Deere dealer to order).

THIS MANUAL SHOULD BE CONSIDERED a permanent part of your machine and should remain with the machine when you sell it.

MEASUREMENTS in this manual are given in both metric and customary U.S. unit equivalents. Use only correct replacement parts and fasteners. Metric and inch fasteners may require a specific metric or inch wrench.

RIGHT-HAND AND LEFT-HAND sides are determined by facing the direction of forward travel.

SETTING FUEL DELIVERY BEYOND PUBLISHED factory specifications or otherwise overpowering will result in loss of warranty protection for this machine.

BEFORE DELIVERING THIS MACHINE, your dealer performed a predelivery inspection to ensure best performance.

THIS TRACTOR IS DESIGNED SOLELY for use in customary lawn mowing operations, for park and amenity area maintenance, and for winter work. Use in any other way is considered as contrary to the intended use.

The manufacturer accepts no liability for damage or injury resulting from this misuse, and these risks must be borne solely by the user. Compliance with and strict adherence to the conditions of operation, service and repair as specified by the manufacturer also constitute essential elements for the intended use.

THIS TRACTOR SHOULD BE OPERATED, serviced and repaired only by persons familiar with all its particular characteristics and acquainted with the relevant safety rules (accident prevention). The accident prevention regulations, all other generally recognized regulations on safety and occupational medicine and the road traffic regulations must be observed at all times.

Any arbitrary modifications carried out on this tractor will relieve the manufacturer of all liability for any resulting damage or injury.

INTRODUCTION

WRITE PRODUCT IDENTIFICATION NUMBERS (P.I.N.) in the space provided below. Accurately record all the numbers to help in tracing the machine should it be stolen. Your dealer also needs these numbers when you order parts. File the identification numbers in a secure place off the machine.

Date of Purchase:

Dealer Name: _____ **Phone:** _____

Engine Serial Number:

JOHN DEERE	
TYP 4100	<input type="text"/>
IDENTIF. NR.	X M041000-----X
ZUL. GESAMTGEWICHT KG	1300 B S 1330
ZUL. ACHS- VORN KG	450 B S 490
LASTEN HINTEN KG	850 B S 900
ZULÄSSIGE ANHÄNGELAST KG	<input type="text"/>
UNGEBREMST	<input type="text"/> 1200
UNABHÄNGIGE BREMSUNG	<input type="text"/> 1200
AUFLAUFGEbremst	<input type="text"/> 1200
HYDR.OD.PNEUM.GEBREMSTANHLAST	<input type="text"/>
KANZAKI KOKYUKOKI MFG.CO.,LTD. AMAGASAKI JAPAN	

Serial Number Plate

Product Identification Number:

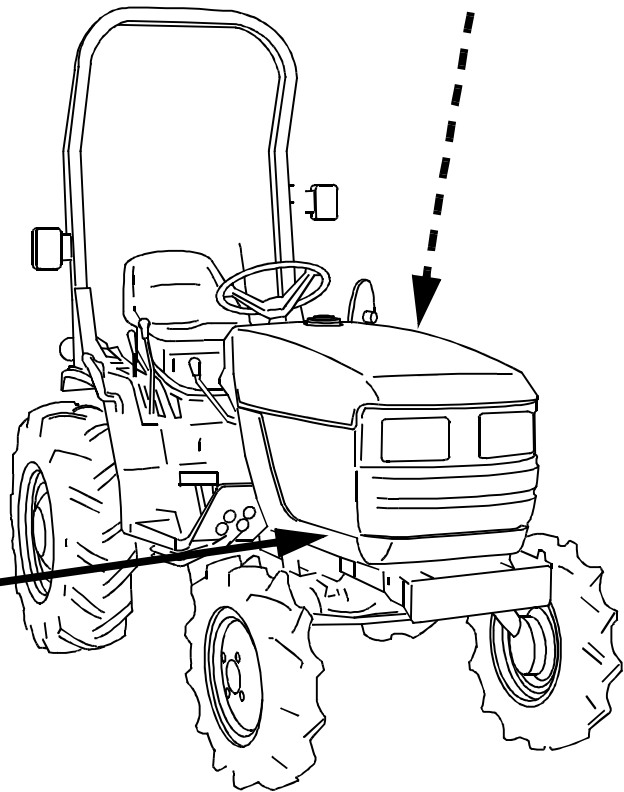

<https://www.ebooklibonline.com>

Hello dear friend!

Thank you very much for reading.

Enter the link into your browser.

The full manual is available for immediate download.

<https://www.ebooklibonline.com>

TABLE OF CONTENTS

Safety Signs	1
Controls	5
Operating Machine	7
Operating Cab Controls	50
Optional Attachments and Kits	53
Replacement Parts	58
Service Machine Safely	59
Service Interval Chart	60
Service Engine	63
Service Transmission	81
Service Electrical	87
Service Miscellaneous	93
Troubleshooting	101
Storing Machine	106
Assembly	108
Specifications	111
Index	123

All information, illustrations and specifications in this manual are based on the latest information at the time of publication. The right is reserved to make changes at any time without notice.

COPYRIGHT© 1998
John Deere Horicon Works
All rights reserved

SAFETY SIGNS

Pictorial Safety Signs

At several important places on this machine safety signs are affixed intended to signify potential danger. The hazard is identified by a pictorial in a warning triangle T. An adjacent pictorial provides information how to avoid personal injury. These safety signs, their placement on the machine and a brief explanatory text are shown in this Safety Signs section.



Avoid Crushing Injuries

- DO NOT jump if machine tips.
- Use machine seat belt.

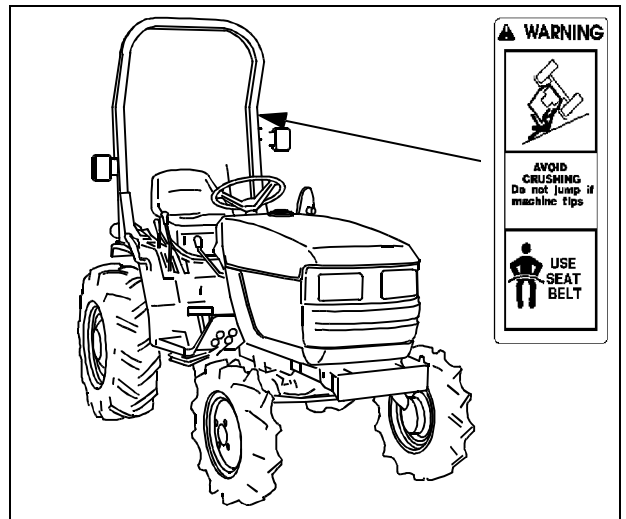

Avoid Injury From Tipping

- DO NOT drive where tractor could slip or tip.
- DO NOT drive on a slope with more than a 13° incline.

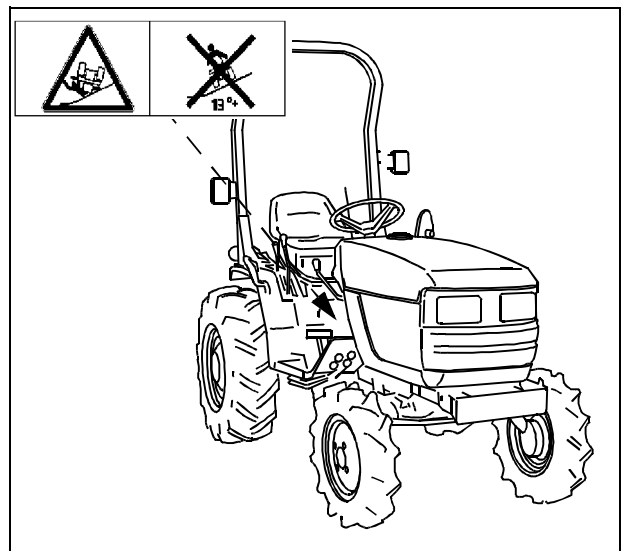

SAFETY SIGNS

Keep Children Away From Mower

Make sure that children stay clear of mower at all times when the engine is running.

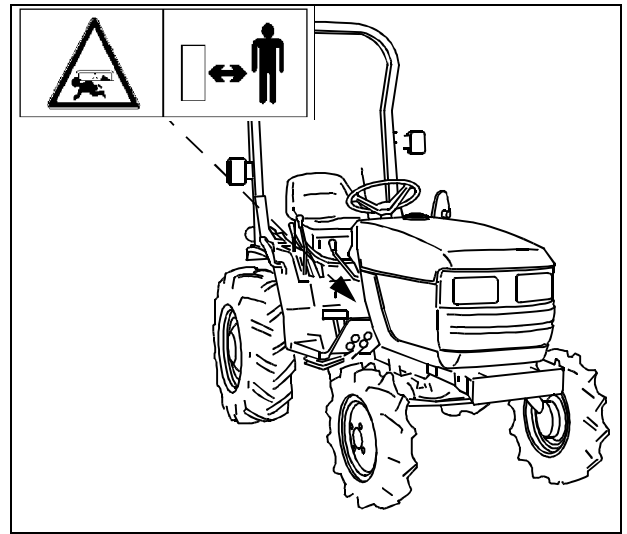

Avoid Injury To Operator and Bystanders

- Read operator's manual before operating this tractor.
- Keep all shields in place.
- Hitch towed loads only to drawbar to avoid rearward upset.
- Make certain everyone is clear of machine before starting engine or operation.
- Keep all riders off tractor and equipment.
- Keep hands, feet and clothing away from power-driven parts.
- Use seat belt. Extend belt completely from any wind-up device before adjusting to fit.
- Reduce speed when turning or applying individual brakes or operating around hazards, on rough ground or steep slopes.
- Couple brake pedals together for road travel.
- Use flashing warning lights on highway unless prohibited by law.
- Stop engine, lower implement to ground, shift to "N" neutral and set park brake securely before dismounting.
- Wait for all movement to stop before servicing machinery.
- Remove key if leaving tractor unattended.

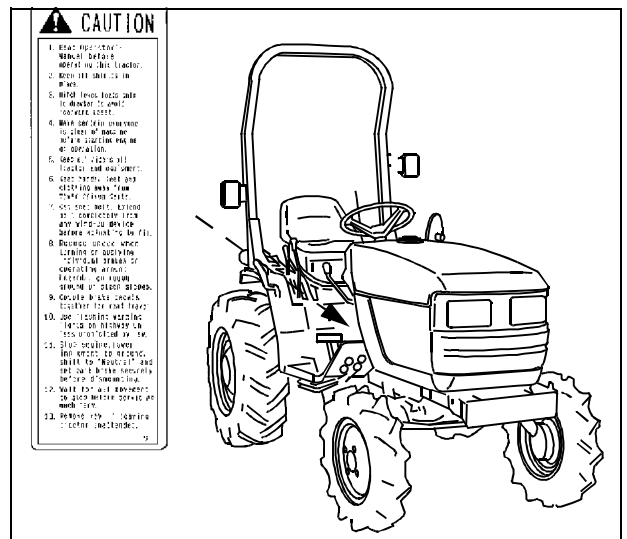

SAFETY SIGNS

Read Operator's Manual

This operator's manual contains important information necessary for safe machine operation. Observe all safety rules to avoid accidents.

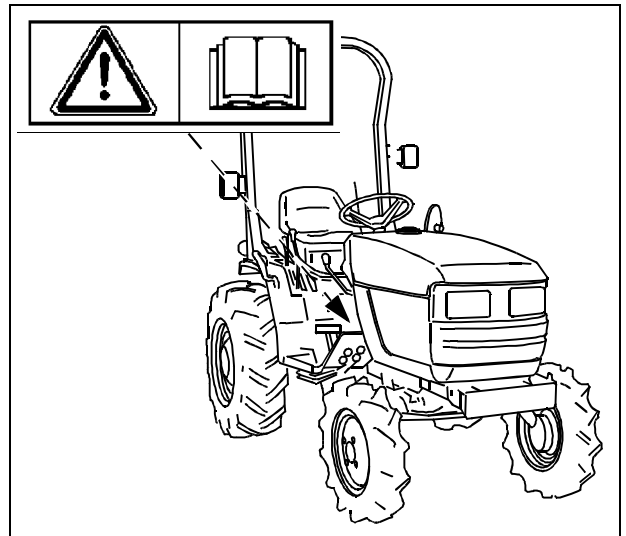

Hot Surface

DO NOT touch muffler, it might be hot.

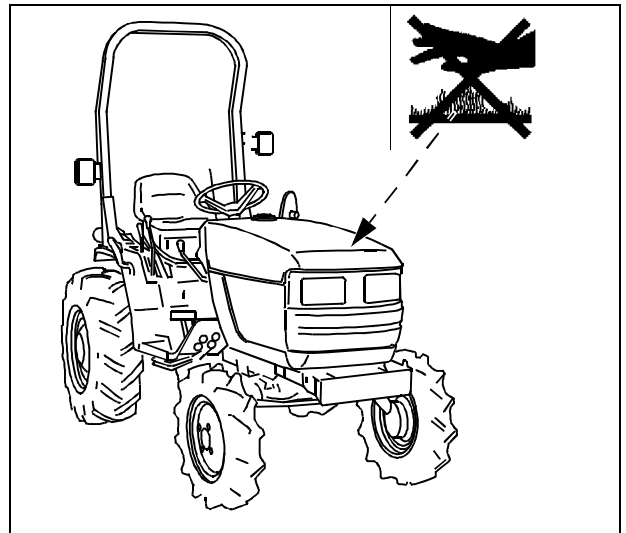

Avoid Injury From Battery Gases and Acids

- Shield eyes. Explosive battery gases and acid can cause blindness or injury. Flush eyes immediately with water and see medical attention.
- Use extreme caution when handling battery
- Keep cigarettes, sparks, and flames away from battery.

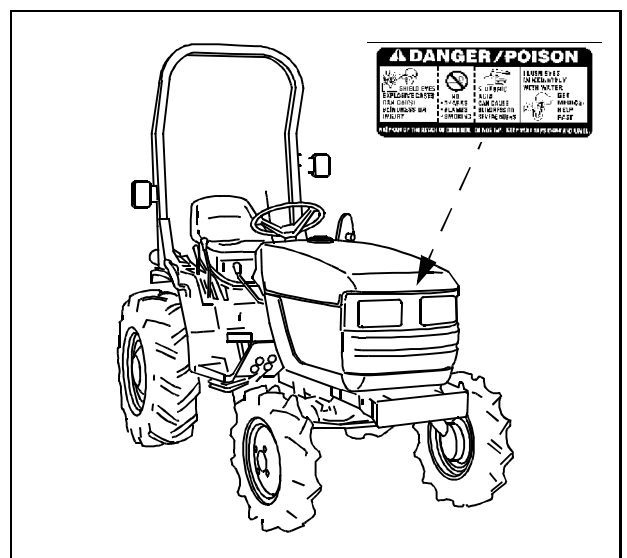

SAFETY SIGNS

Avoid Injury From Rear Rotating Driveshaft

- Keep hands, feet and clothing away from rear rotating driveshaft.
- Keep all shields in place.
- Operate rear driveshaft only at 540 RPM.



CONTROLS

Operator Station Controls

- A - Clutch Pedal
- B - Instrument Panel
- C - Key Switch
- D - Hand Throttle
- E - Brake Pedals
- F - Foot Throttle
- G - Speed of Drop / Lock Valve
- H - Differential Lock Lever
- I - Operator Seat Adjustment Lever
- J - Depth Control Lever
- K - Seat Belt
- L - Operator Seat
- M - Power Take Off (PTO) Lever
- N - Gear Shift Lever
- O - 2-Speed Range and Direction Lever
- P - Parking Brake
- Q - Four Wheel Drive (4WD) Lever

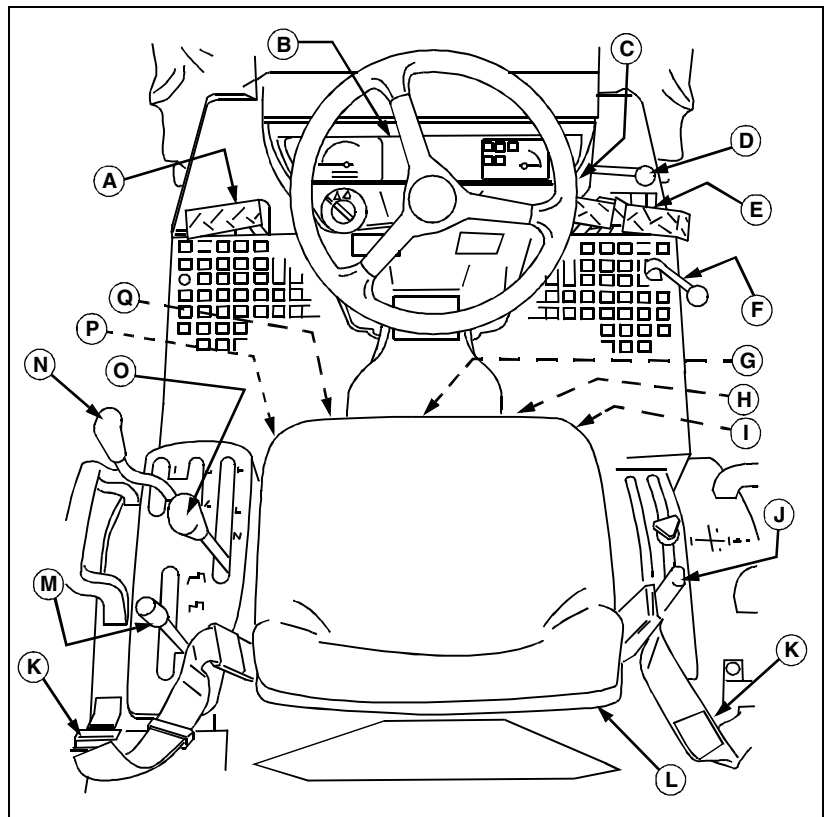

Instrument Panel

NOTE: Steering wheel removed for clarity of photo.

- A - Tachometer
- B - Light - Warning Flasher Lamps
- C - Hour Meter
- D - "T" Light - Tractor Warning Lamps
- E - "1" Light - 1st Trailer Indicator
- F - "2" Light - 2nd Trailer Indicator
- G - Light - Engine Coolant Temperature
- H - Light - PTO Engage
- I - Light - Parking Brake Set
- J - Light - Engine Oil Pressure
- K - Light - Battery Low Voltage
- L - Fuel Gauge
- M - Horn Switch
- N - Warning Flasher Switch
- O - Turn Signal Switch
- P - Light - Turn Signal Indicator
- Q - Light Switch

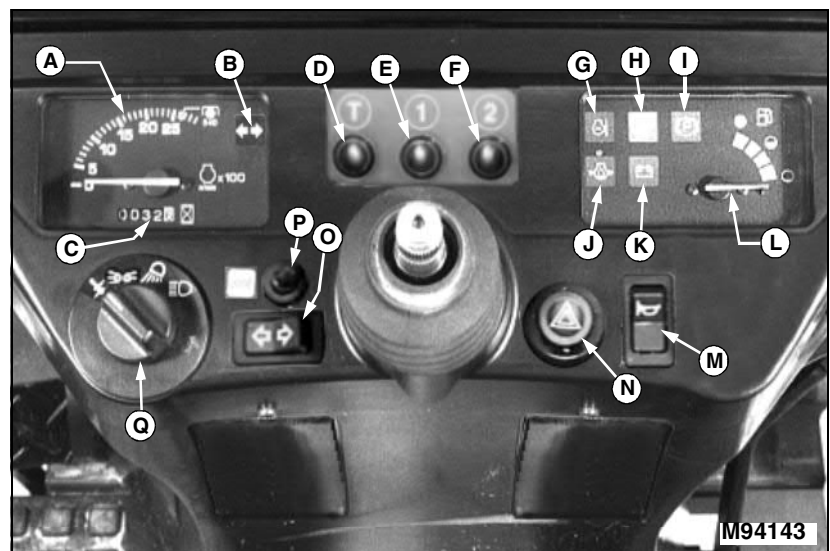

CONTROLS

Hood Controls

- A - Hood Release
- B - Hood Support

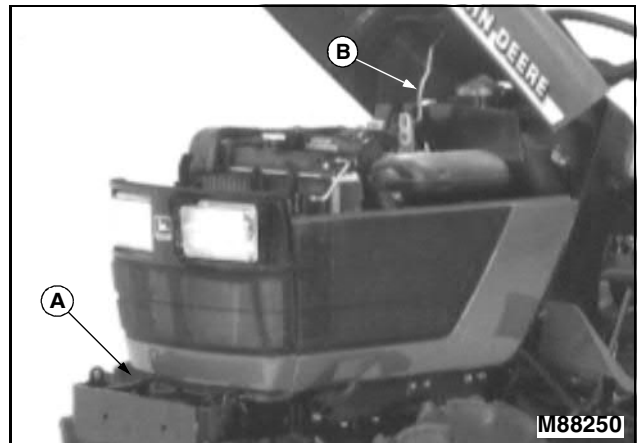

3-Point Hitch

- A - Center Link Storage Hook
- B - Lift Arms
- C - Center Link
- D - Lift Link - Solid
- E - Lift Link - Adjustable
- F - Sway Links
- G - Draft Links

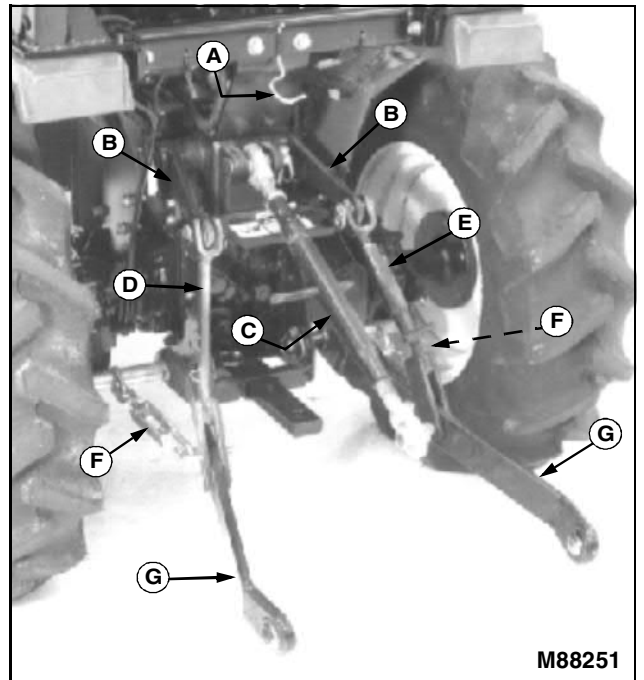

OPERATING MACHINE

Operate Safely

- Check brake action before you operate. Adjust or service brakes as necessary.
- Inspect machine before you operate. Be sure hardware is tight. Repair or replace damaged, badly worn, or missing parts. Be sure guards and shields are in good condition and fastened in place. Make any necessary adjustments before you operate.
- Clear work area of objects that might be thrown. Keep people and pets out of the work area. Stop machine if anyone enters the area.
- If you hit an object, stop the machine and inspect it. Make repairs before you operate. Keep machine and attachments properly maintained and in good working order.
- DO NOT leave machine unattended when it is running.
- Only operate during daylight or with good artificial light.
- Be careful of traffic when operating near or crossing roadways.
- Do not wear radio or music headphones while operating the machine. Safe operation requires your full attention.

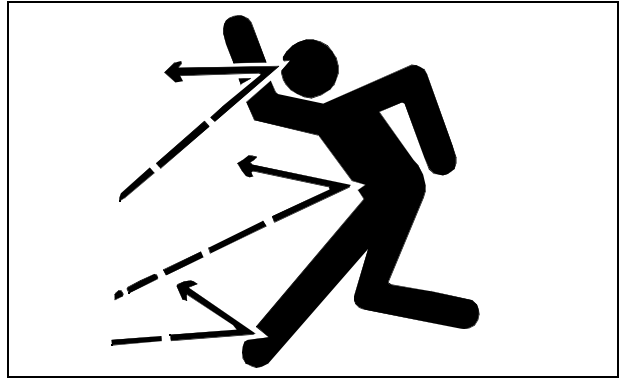

Park Safely

- Stop machine on a level surface, not on a slope.
- Disengage PTO.
- Lock brake levers.
- STOP engine.
- Remove key.
- Before you leave the operator's station, wait for engine and all moving parts to STOP.

OPERATING MACHINE

Rotating Blades Are Dangerous - Protect Children And Prevent Accidents

PROTECT CHILDREN:

- Never assume that children will remain where you last saw them. Children are attracted to mowing activity, stay alert to the presence of children.
- Keep children in the house when you are operating the machine.
- Turn machine off if a child enters the mowing area.
- Use extra care when you come to blind corners, shrubs, trees, or other objects that may block your vision.
- DO NOT let children or an untrained person operate the machine.
- DO NOT carry or let children ride on machine or any attachment. DO NOT tow children in a cart or trailer.

HELP PREVENT SERIOUS OR FATAL ACCIDENTS:

- Be alert at all times, drive forward carefully. People ESPECIALLY CHILDREN can move quickly into the mowing area before you know it.
- Back carefully. Shut off PTO and look behind the machine carefully, ESPECIALLY FOR CHILDREN, before you back up.
- DO NOT mow in reverse unless it is absolutely necessary.
- Shut off PTO when you are not mowing.
- DO NOT operate machine if you are under the influence of drugs or alcohol.

Use Seat Belt Properly

Use a seat belt when you operate with a roll-over protective structure (ROPS) or cab to minimize chance of injury from an accident such as an overturn.

Do not use a seat belt if operating without a ROPS or cab.

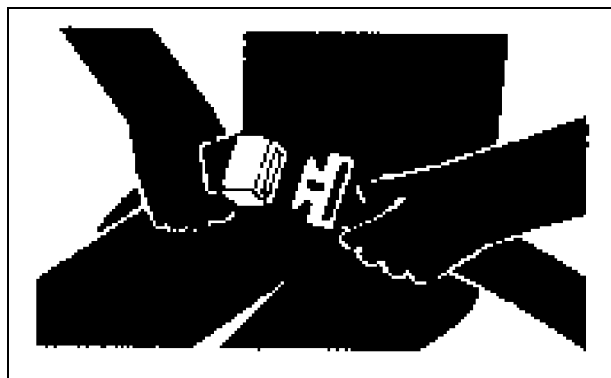
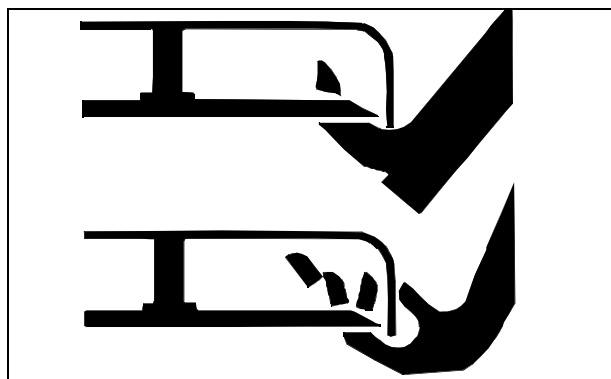

OPERATING MACHINE

Avoid Tipping

DO NOT drive where machine could slip or tip.

- Stay alert for holes and other hidden hazards in the terrain.
- Keep away from drop-offs.
- Slow down before you make a sharp turn or operate on a slope.
- When pulling loads or using heavy equipment, use only approved hitches, limit loads to those you can safely control, and use counterweights or wheel weights when required per this manual or your attachment manual.
- Drive up and down a hill - not across. Be careful when you change direction on a slope.
- DO NOT stop when going up hill or down hill. If machine stops going up hill, STOP PTO and back down slowly.
- DO NOT mow wet grass. Reduced traction could cause sliding.
- DO NOT try to stabilize the machine by putting your foot on the ground.

Operator Training Required

Study operating section of this manual before operating the machine.

- Operate machine in an open, unobstructed area under the direction of an experienced operator.
- Learn the use of all controls.
- Operator experience is required to learn the moving, stopping, turning and other operating characteristics of the machine.

Keep Riders Off

Only allow the operator on the machine. Keep riders off.

- Riders on the machine or attachment may be struck by foreign objects or thrown off the machine causing serious injury.
- Riders obstruct the operator's view resulting in the machine being operated in an unsafe manner.

OPERATING MACHINE

Wear Appropriate Clothing

- Wear close fitting clothing and safety equipment appropriate for the job.
- Loud noise can cause impairment or loss of hearing, wear a suitable protective device such as earplugs.

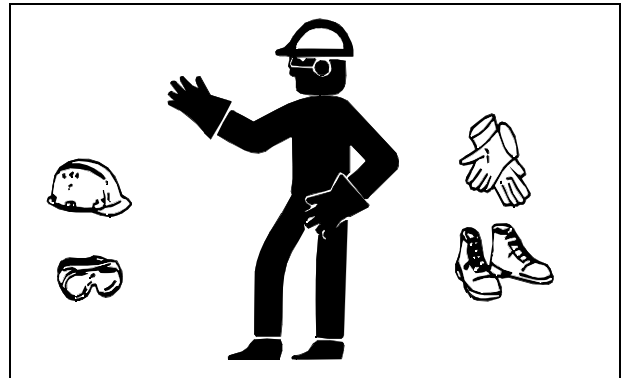

Stay Clear of Rotating Drivelines

Entanglement in rotating driveline can cause serious injury or death:

- Wear close fitting clothing.
- STOP the engine and be sure PTO driveline is stopped before getting near it.



Check Wheel Bolts

A serious accident could occur causing serious injury if wheel bolts are not tight.

- Check wheel bolt tightness often during the first 100 hours of operation.

Transport Safely

Use safety lights and devices. Slow moving machines when driven on public roads are hard to see, especially at night. Avoid personal injury or death resulting from a collision with a vehicle.

- Whenever driving on public roads, use flashing warning lights and turn signals according to local regulations. Extra flashing warning lights may need to be installed.

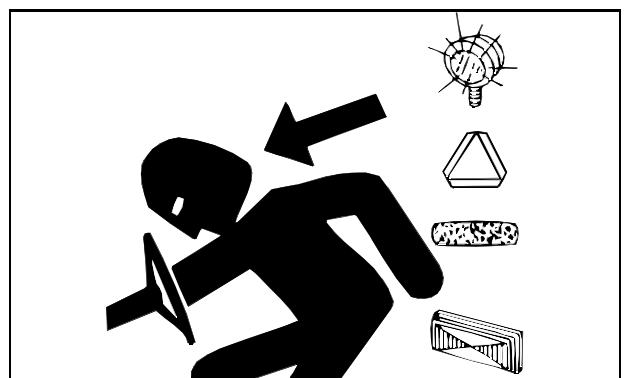

OPERATING MACHINE

Adjusting Operator Seat

NOTE: The symbols on the seat base give instructions for making adjustments for the size of operator.

Adjust operator's seat:

- Move knob (A) to adjust for operator's height.
- Move lever (B) to adjust for operator's weight.
- Move lever (C) to slide seat forward or rearward for operator's reach.

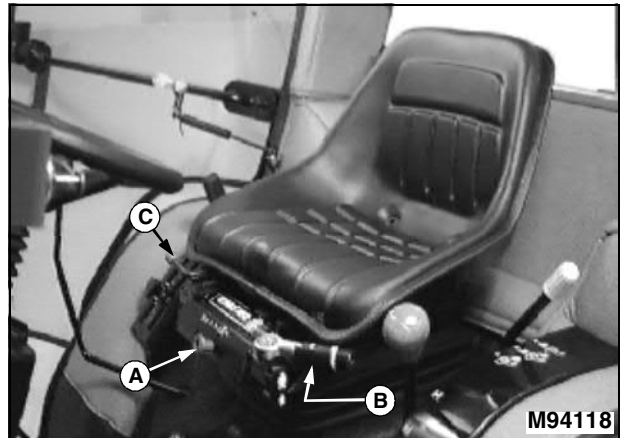

Using Seat Belt

CAUTION: Use a seat belt when you operate with a Roll-Over Protective Structure (ROPS) to minimize chance of injury from an accident, such as an overturn.
Do not use a seat belt if operating without a ROPS.

Connect both end of the seat belt until they "CLICK" together. Tighten or loosen seat belt until you are firmly held onto the seat.

To release seat belt, "PRESS" the red button.

Using Ignition Switch

IMPORTANT: When tractor is not being used or when tractor is being serviced, make sure key switch is in the "O" off position and the key is removed.

A - "O" Off Position - In this position the engine will not be running.

B - "I" On Position - Move key from "O" to this position and the Engine Oil Pressure Light and Battery Charging Light will turn on. You will also hear the engine fuel shut-off solenoid engage with a CLICK.

C - "R" Position - Move key from "I" to this position and the starter will engage the engine flywheel to start the engine. When the key is released it will automatically return to the "I" position allowing the engine to run.

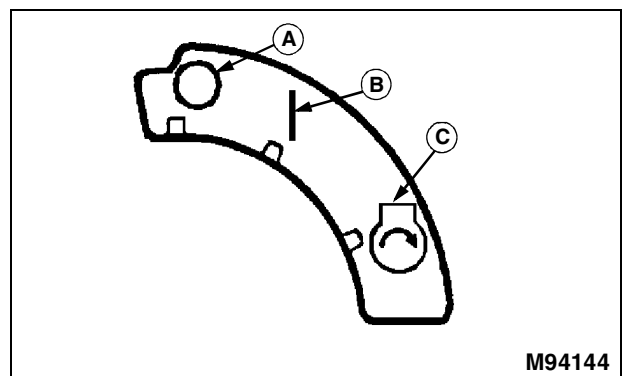

OPERATING MACHINE

Understanding Instrument Panel - Right Side

A - Engine Coolant Temperature Light - This light will turn on when the engine coolant is approaching a dangerously hot temperature. If this light turns on, remove load on tractor immediately. Reduce engine to idle speed and check for something blocking air flow to the radiator and check engine coolant level. If light stays on after cleaning grille, STOP engine.

B - PTO Engaged Light - This light will turn on when the PTO is engaged.

C - Parking Brake Set Light - This light will turn on and flash when the Parking Brake is set.

D - Engine Oil Pressure Light - This light will turn on when the ignition key is in the "I" on position and the engine is not running. If this light turns on while the engine is running, STOP engine. This light will turn on when engine oil pressure is too low. This is an indication that the engine is low on oil.

E - Battery Charging Light - This light will turn on when the ignition key is in the "I" on position and the engine is not running. If this light turns on while the engine is running, move the throttle lever to the full throttle position. Stop the engine if light remains on. This light will turn on when the alternator output is too low.

F - Fuel Gauge - Show approximately how much fuel is in the fuel tank. Includes Full marker, Half-Full marker and Empty marker.

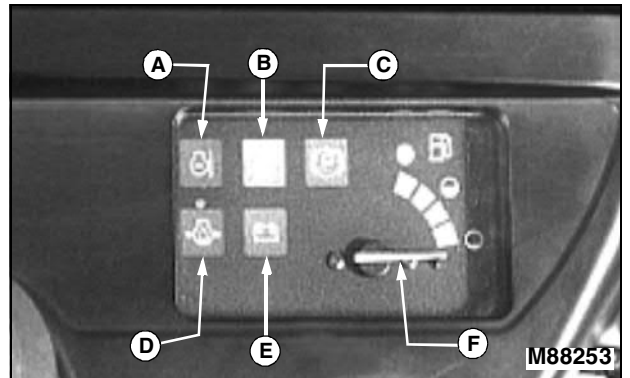

OPERATING MACHINE

Understanding Instrument Panel - Left Side

A - **Tachometer** - Shows engine speed. Engine speed is shown in 100's. Example: If indicator is pointing at 20 (20 x 100 = 2000 RPM). Note the special marker labeled "540 p" - With the indicator pointing at the "540 p" marker, this is the proper engine speed for the 540 RPM Power Take Off (PTO).

- Slow idle speed..... 1025 rpm
- Rated speed 2650 rpm
- Fast speed.....2860 rpm

B - **Warning Flasher Lights ON Light** - This light will turn on and Flash when the Light Switch is turned to the Warning Flasher Lights ON position or Headlights, Taillights and Warning Flasher Lights ON position.

C - **Hour Meter** - Shows the number of used hours the engine has run at 2650 rpm. If engine has run at less than 2650 rpm, the indicated hours are less than the actual running hours. Use the hour meter as a guide when servicing various components of this tractor.

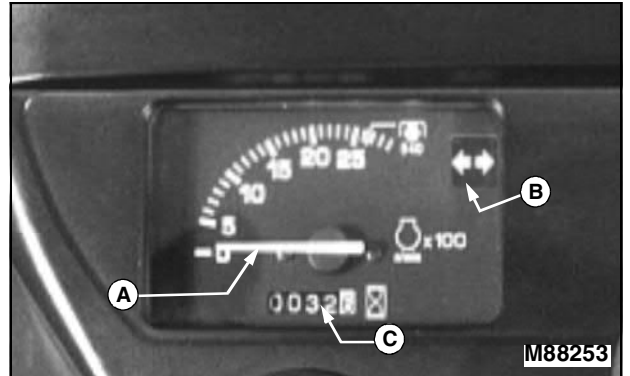

Using Light Switch

NOTE: The light switch will operate only when the ignition key is in the "I" on position.

Rotate switch to the desired position.

- A - All Lights OFF
- B - Warning Flasher Lights ON
- C - Headlights and Taillights ON
- D - Headlights, Taillights and Warning Flasher Lights ON

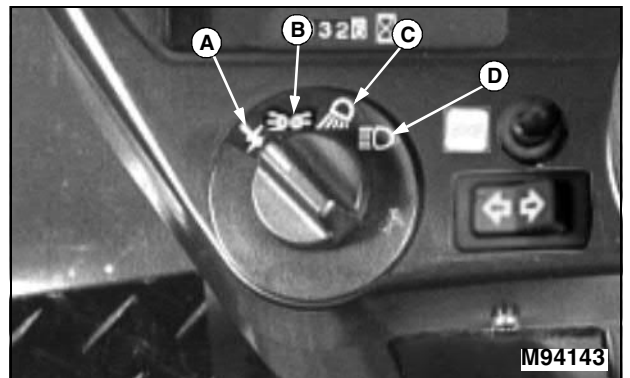

OPERATING MACHINE

Using Turn Signals

NOTE: The turn signal will operate only when the ignition key is in the "I" on position.

The turn signal switch (A) is a three position rocker switch:

- Left Turn Signal - push arrow pointing to the left.
- Off - center position.
- Right Turn Signal - push arrow pointing to the right.

When either turn signal is activated the turn signal indicator light (B) will flash.

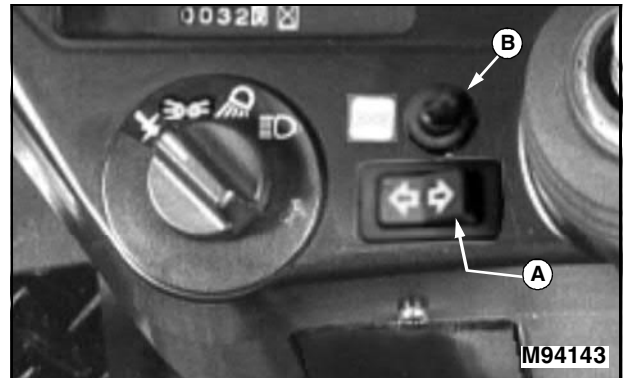

Using Hazard Warning Lamps

The hazard warning switch (A) is a two position switch:

- Hazard Warning Lamps On - push button down to the on position - button will stay down in the on position.
- Hazard Warning Lamps Off - push button down again and button will return to the off position.



Using Horn

The horn switch (A) is a rocker switch with auto return to the off position. To sound horn, press horn switch (A). Release switch and horn will automatically stop.



Using Control Panel Indicator Lights

NOTE: Steering wheel removed for clarity of photo.

The three indicator lights work with the warning lights:

- Light "T" - will flash to show the operator that the tractor turn signal is on.
- Light "1" - will flash when one trailer is hooked up to the tractor and the turn signal is on.
- Light "2" - will flash when a second trailer is towed behind the first trailer and the turn signal is on.





Suggest:

If the above button click is invalid.

Please download this document

first, and then click the above link

to download the complete manual.

Thank you so much for reading

OPERATING MACHINE

Using Throttle

Use the throttle to change engine speeds. Use the throttle in conjunction with the Tachometer (A) to set engine speeds.

This tractor is equipped with a hand throttle (B) and a foot throttle (C). Throttle operation:

Hand Throttle

- Decrease Engine Speed - Pull throttle lever (B) towards rear of the tractor.
- Increase Engine Speed - Push throttle lever (B) towards the front of the tractor.

Foot Throttle

NOTE: The foot throttle can be used in conjunction with the hand throttle. Example: Use hand throttle to set engine speed at 2000 rpm - now use foot throttle to increase engine speed to 2860 rpm. Release foot throttle and engine speed will return to hand throttle setting of 2000 rpm.

- Increase engine speed by pushing down on throttle pedal (C). Release throttle pedal and engine speed automatically slows down.

Engine / Tachometer Speeds:

- Slow Idle Speed..... 1025 rpm
- Special Marker "540 p"2650 rpm
- Rated Speed.....2650 rpm
- Fast Speed.2860 rpm

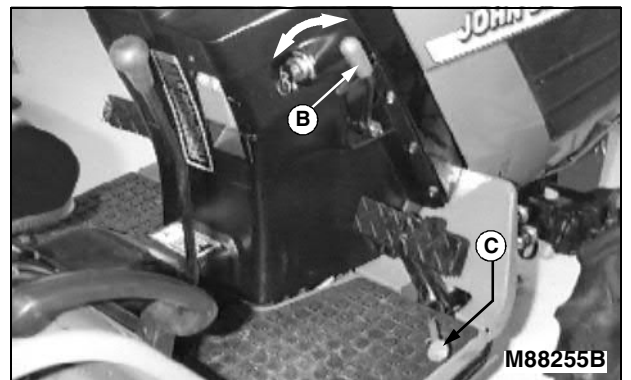

<https://www.ebooklibonline.com>

Hello dear friend!

Thank you very much for reading.

Enter the link into your browser.

The full manual is available for immediate download.

<https://www.ebooklibonline.com>