

# JOHN DEERE 3300 COMBINE



## OPERATORS MANUAL JOHN DEERE 3300 COMBINE

OMH86802 J3 English

**OMH86802 J3**

LITHO IN THE U.S.A.  
ENGLISH





## To the Purchaser

This new combine was carefully designed and manufactured to give years of dependable service. To keep it running efficiently, read the instructions in this operator's manual. Each section is clearly identified so you can easily find the information you need—whether it is operation, lubrication, or service. Read the Table of Contents to learn where each section is located. Use the alphabetical index for fast reference.

This operator's manual covers the feeder house and separator areas of the combine. For platform and corn head information, see the separate operator's manuals furnished with this equipment.

In addition to the equipment furnished with your combine, attachments are available to help you do a better job in special crop conditions. These are described in the attachments section of this manual and can be purchased from your John Deere dealer.

"Right-hand" and "left-hand" sides are determined by facing in the direction the combine will travel when

in use. The radiator end of the engine is referred to as the "front," the flywheel end as the "rear."

 This safety alert symbol identifies important safety messages in this manual. When you see this symbol, be alert to the possibility of personal injury and carefully read the message that follows.

Record your combine serial numbers in the space provided on page 169. Your dealer needs this information to give you prompt, efficient service when you order parts or attachments. If your combine requires replacement parts, go to your John Deere dealer where you can obtain Genuine John Deere parts—accept no substitutes.

The warranty on this combine appears on your copy of the purchase order which you should have received from your dealer when you purchased the combine.





# Contents

	Page
Controls and instruments .....	2-4
Operation .....	5-42
Safety suggestions .....	43
Fuels and lubricants .....	44-45
Lubrication and periodic service .....	46-57
Service .....	58-137
Trouble shooting .....	139-156
Storage .....	157-159
Attachments .....	160-165
Specifications .....	166-171
Index .....	172-175

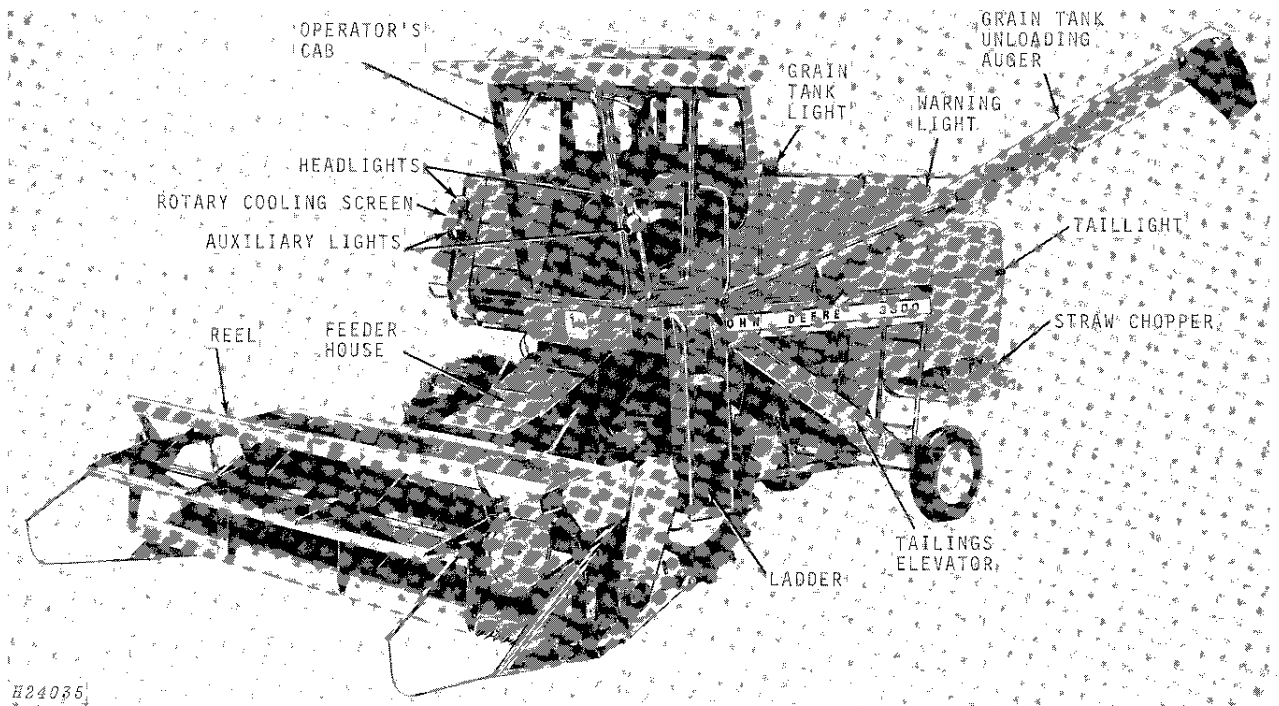

H24035

John Deere 3300 Combine

**<https://www.ebooklibonline.com>**

Hello dear friend!

Thank you very much for reading.

Enter the link into your browser.

The full manual is available for immediate download.

**<https://www.ebooklibonline.com>**



# Controls and Instruments

This section illustrates all controls and instruments necessary for successful field operation. For an explanation of each control and instrument, refer to the page reference given.

Before attempting to operate your new combine, become familiar with the location and purpose of its controls and instruments. Study these pages carefully, regardless of your previous combine experience.

The control levers and knobs have different colors and shapes. These have been designed to help you quickly locate the controls while operating the combine. Colors on controls indicate:

RED . . . . .Combine movement controls (Throttle, Gearshift Lever, Selective Ground Speed Control)

## OPERATOR'S PLATFORM

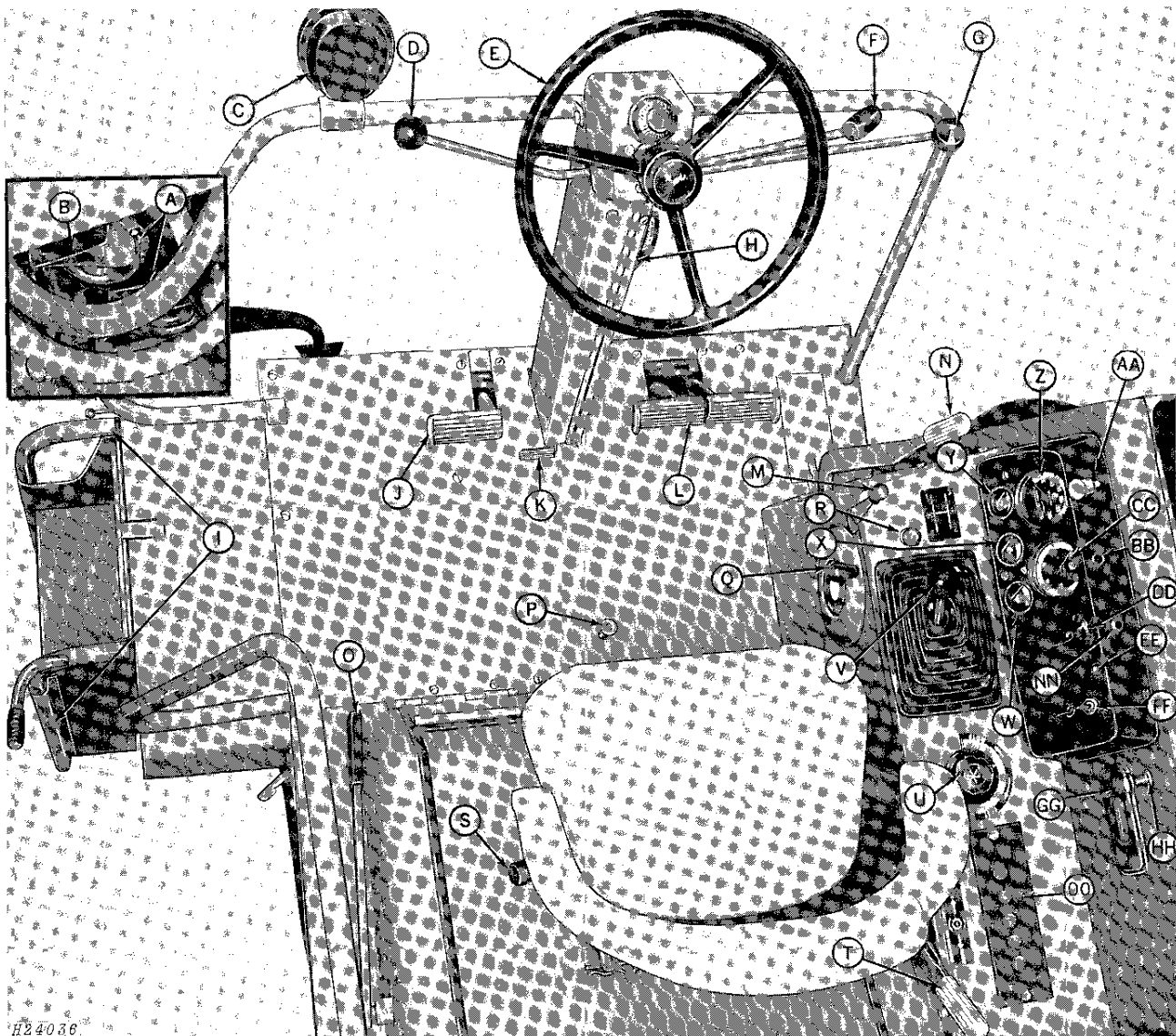

YELLOW . . . . Auxiliary Power Controls (Separator Control Lever, Cylinder Speed Ratchet Control, Platform or Corn Head Electromagnetic Clutch Switch)

BLACK . . . . Miscellaneous Function Controls (Platform or Corn Head Height Control, Hydraulic Lift Reel Control, etc.)

**ENGINE - AIR INTAKE**

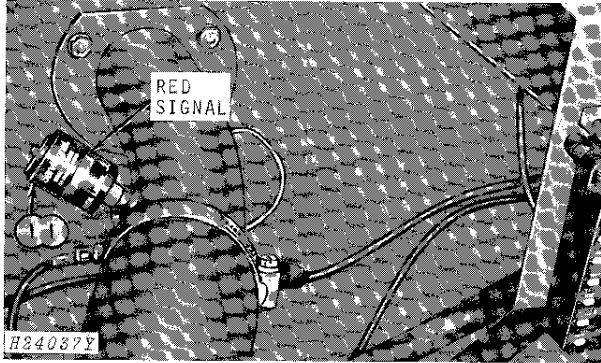

*Diesel Engine Illustrated*

**FEEDER HOUSE**

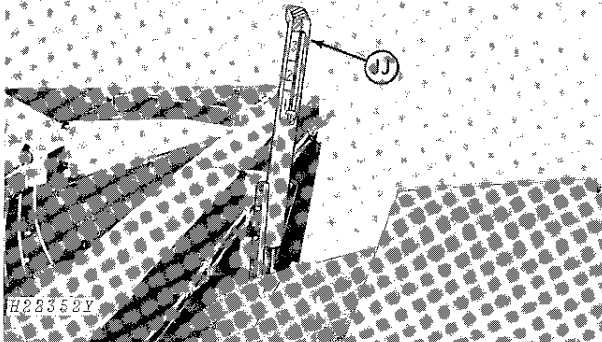

	Page
A - Truck Signal Horns .....	37
B - Coolant Temperature Warning Horn or Straw Walker Warning Horn (Attachment).....	9,37,164
C - Headlight.....	37
D - Hydraulic Lift Reel Control (Optional) .....	19,160
E - Steering Wheel .....	34
F - Selective Ground Speed Control.....	34
G - Platform or Corn Head Height Control Lever.....	19
H - Ground Speed Indicator (Attachment) .....	34
I - Pivoting Ladder.....	14
J - Clutch Pedal .....	35,105
K - Steering Column Control Pedal .....	14
L - Brake Pedals .....	35,105,106
M - Throttle .....	8
N - Separator Control Lever .....	24
O - Grain Tank Unloading Auger Lever .....	33
P - Parking Brake Lock Button.....	34
Q - Concave Opening Control Wheel.....	25

**SEPARATOR**

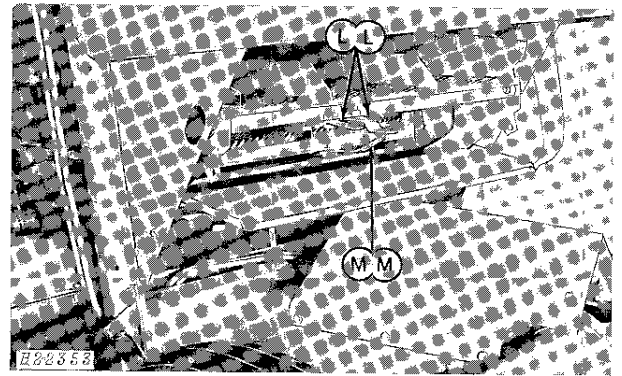
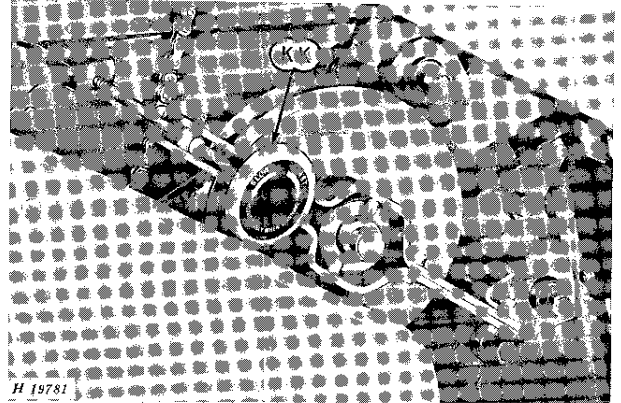

	Page
R - Choke—Gasoline only.....	8
S - Operator's Seat Control Lever.....	13
T - Cylinder Speed Control Ratchet.....	24
U - Hydrostatic Drive Reel Control or Hydrostatic Drive Belt Pickup (Optional).....	19,159,160
V - Gearshift Lever .....	34
W - Coolant Temperature Gauge.....	8
X - Engine Oil Pressure Gauge .....	9
Y - Fuel Gauge.....	9
Z - Engine Tach-Hour Meter.....	9
AA - Platform or Corn Head Electromagnetic Clutch Switch (Optional).....	18,19
BB - Alternator Indicator Light .....	24
CC - Cylinder Speed Tachometer.....	8
DD - Light Switch .....	37
EE - Horn Button.....	37
FF - Key Switch .....	8
GG - Ash Tray.....	37
HH - Cigarette Lighter.....	37
II - Air Restriction Indicator (Attachment).....	3,9,133
JJ - Platform Float Spring Indicator (Attachment).....	161
KK - Fan Speed Control Wheel .....	30
LL - Chaffer Opening Control Levers .....	31
MM - Sieve Opening Control Lever.....	31
NN - Cold Weather Starting Aid (Diesel only) (Attachment).....	7,37
OO - Low Shaft Speed Indicator (Attachment).....	15,16

## OPERATOR'S CAB CONTROLS

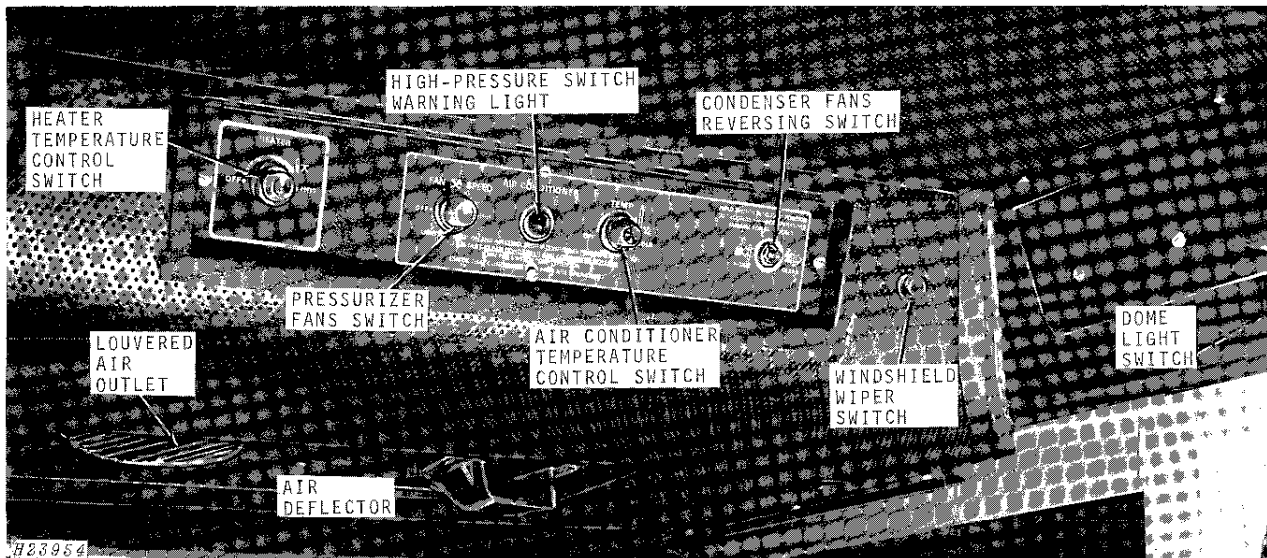

The operator's cab controls are conveniently located in the cab headliner to the front and side of the operator. The radio is located in the rear right-hand corner of the cab.

### Heater Temperature Control Switch (Attachment)

The amount of heat in the cab is controlled by turning the heater control switch clockwise, from the "OFF" position toward the "HOT" position. Turning the switch all the way to the "HOT" position will provide maximum heating.

### Air Conditioner Temperature Control Switch (Attachment)

The air conditioner temperature control switch is a thermostatic-type switch which will maintain the desired temperature.

Cool air in the cab is controlled by turning the air conditioner temperature control switch from the "OFF" position clockwise toward the "COLD" position. Turning the switch all the way to the "COLD" position will provide maximum cooling.

### Condenser Fans Reversing Switch (Attachment)

When pushed to the right, this toggle-type switch will reverse the three condenser fans located in the cab roof. When released, it will automatically return to normal operating position.

**IMPORTANT: Operate this reversing switch once every grain tank load for approximately 30 seconds, to clean the condenser core of any dirt or chaff.**

### Pressurizer Fans Switch

This switch controls the fans which pressurize the cab. This is a three-speed switch with the highest speed obtained by turning the switch clockwise as far as it will go.

**IMPORTANT: Pressurizer fans must be operating whenever the heater or air conditioner is in use.**

### High-Pressure Switch Warning Light (Attachment)

This light will glow red when the high-pressure switch has activated indicating that it may be necessary to clean the condenser. See page 136.

### Louvered Air Outlets

The air outlets are adjustable, enabling the operator to control the flow of air into the cab. The outlets can be turned 360 degrees. One of the air outlets is equipped with an air deflector to further control air flow.

### Windshield Wiper Switch (Attachment)

This is a two-speed switch. Turning the switch clockwise to the first detent will give normal wiper operation. The second detent position will produce a faster wiper action. When the switch is turned all the way counterclockwise, the wiper will return to its stop position.

### Dome Light Switch

Moving this toggle-type switch to the right turns the dome light on; moving this switch to the left turns the light off.



# Operation

## COMBINE AND ENGINE BREAK-IN ENGINE BREAK-IN PROCEDURE

Step	Time	Engine RPM	Load
1	15 min.	1200	None
2	15 min.	1500 - 1600	None
3	30 min.	1500 - 1600	Separator engaged
*4	2-1/2 hr.	1900 - 2000	Separator engaged
5	30 min.	Full throttle	Separator engaged
6	2 min.	1200	None

During break-in, monitor oil pressure, water temperature, and check for leaks.

\*After this run, loosen cylinder head bolts 5 to 10 degrees; then retighten bolts one at a time, in sequence, to specified torque. Check and reset valve clearance per specifications on pages 168 and 169.

After break-in, drain crankcase oil and remove filter. Install new filter and fill crankcase with oil of proper viscosity and service classification.

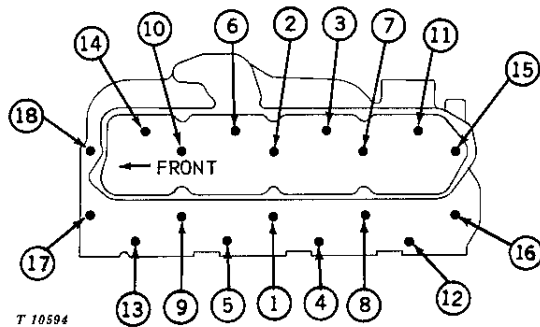

Cylinder Head Cap Screw Tightening Sequence

For break-in we recommend John Deere Torq-Gard Supreme SAE 10W-20 for temperatures above  $-10^{\circ}\text{F}$ . It has adequate strength to protect engine parts at high ambient temperatures. Torq-Gard Supreme SAE 30, even at high ambient temperatures, gives a slower break-in. If ambient temperature is below  $-10^{\circ}\text{F}$ ., and if a crankcase oil heater is not used, it would be advisable to use Torq-Gard Supreme SAE 5W-20 to insure fluidity of oil when starting the engine.

If oil other than Torq-Gard Supreme is used for break-in, it should be qualified as meeting MIL-L-46152 specification limits. If not available, use MIL-L-2014C or designated for API service CD/SD. Depending on the expected prevailing temperature range for the break-in period, use oil of viscosity as shown in the temperature charts on page 45.

**IMPORTANT: DO NOT USE the so-called "break-in" oils; they may be low or nondetergent type oils that could cause diesel piston rings to stick before the first oil change.**

DO NOT USE break-in powder in ANY engine. Engineering tests on John Deere engines have determined that break-in powder is no longer necessary to obtain satisfactory piston ring seating and it will reduce the life of the engine.

**IMPORTANT: Avoid excessive engine idling during first 100 hours of operation. Change the oil and filter at 100 hour period. Fill with new oil.**

### COMBINE BREAK-IN

Follow the lubrication instructions closely. See pages 46 to 57.

Check coolant level in radiator and add coolant if necessary. Do not use water containing alkali. If combine is being operated in temperatures below 40°F., refer to "Cold Weather Operation," page 7.

#### After 1 Hour

Check torque on drive wheel bolts. Tighten bolts to 180 ft-lbs torque.

#### After 5 Hours

Check all V-belts for initial stretch. Tighten if necessary. Continue to check V-belts every few hours for the first 50 hours.

#### After 20 Hours

Drain oil from hydraulic unit reservoir. Replace the oil filter and fill the reservoir with correct oil as specified on page 45. Thereafter, drain and replace oil and oil filter element every 500 hours of operation.

#### After 100 Hours

After the first 100 hours of operation, drain oil from crankcase, replace oil filter, and fill crankcase to proper level with John Deere Torq-Gard Supreme engine oil or its equivalent as specified in lubricants chart on page 45.

Thereafter change the oil and filter every 100 hours of operation or every season, whichever occurs first.

### Rotary Cooling Screen

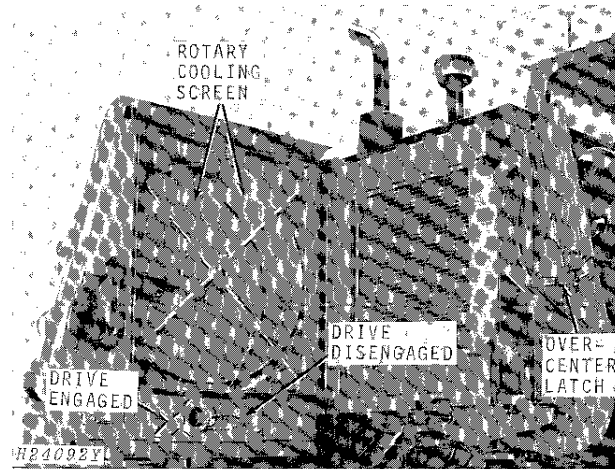

Screen Door Open for Illustrative Purposes

The rotary screen drive must be engaged whenever the engine is running.

To engage drive, move lever down and forward.

To disengage drive, move lever rearward and up.

*NOTE: Screen door must be closed to engage or disengage drive.*

## COLD WEATHER OPERATION

### FUEL SYSTEM

Use winter-grade fuel. Fill the fuel tank at the end of the day's run to prevent moisture from condensing in the fuel tank.

### COOLING SYSTEM

Drain, flush, and fill cooling system with a recognized brand of radiator sealer and antifreeze solution. Use a permanent-type (ethylene glycol) antifreeze solution containing rust inhibitors. This type of antifreeze is resistant to evaporation when heated. Do not use antifreeze which contains stop leak additives.

#### Quarts of Ethylene Glycol Required at Lowest Expected Temperature

+20°F.	+10°F.	0°F.	-10°F.	-20°F.	-34°F.
4	7	9	11	12	14

After filling, check system for leaks.

### BATTERY

When the temperature drops below freezing, be sure battery is fully charged. A badly discharged battery freezes more quickly than one that is well charged. For example, a battery with a specific gravity reading of 1.175 (discharged) will freeze at 4°F., and a battery with specific gravity reading 1.300 (fully charged) will not freeze until the temperature reaches -65°F.

In freezing weather, do not add water to the battery unless engine is going to be run. Water will freeze as it will not mix with the electrolyte until the alternator passes a charging current through the battery.

**IMPORTANT:** If booster battery is required, see instructions on page 112.

### COLD WEATHER STARTING AID (Attachment)

Diesel engines may be equipped with an ether starting fluid aid which injects atomized fluid into the engine air intake system. Normally, ether is used for starting at temperatures below 40°F. Pressurized cans of starting fluid are available from your John Deere dealer.

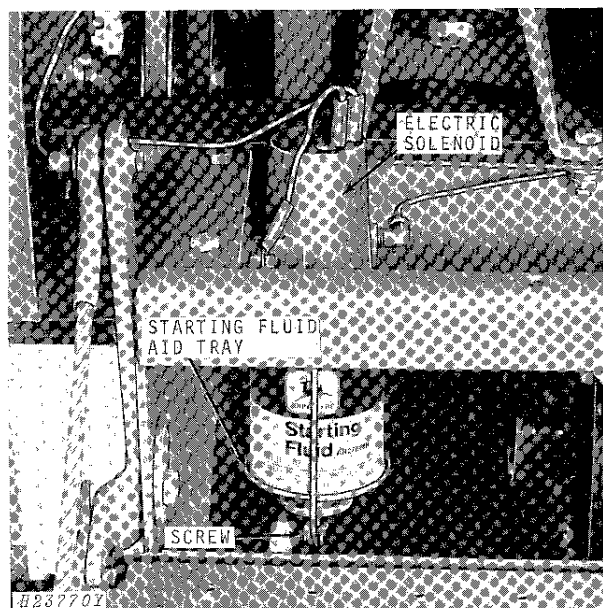

*Engine Bottom Shield Removed For Illustrative Purposes*

To use the starting fluid aid, remove the safety cap and plastic spray button from can. Loosen screw and place can in starting fluid aid tray. Position can directly under electric solenoid. Tighten screw by hand until nozzle of can is securely seated in the solenoid.

**IMPORTANT:** To avoid damage, turn engine with starter one or two revolutions before injecting starting fluid. Inject starting fluid only while the engine is turning.

To inject starting fluid, press starting aid button (button with gray cap) located on instrument panel.

Stop injecting fluid after the engine starts. If the engine begins to die during the first few minutes of operation, inject another "shot" of fluid.

**IMPORTANT:** Fluid can must be left in tray, even if empty, to prevent dirt from being drawn into the engine.

**CAUTION:** Ether starting fluid is highly flammable. Store starting fluid cans where they will not be subject to extreme cold or warm temperatures. For best results, store fluid at room temperature.

## HOT WEATHER OPERATION

Protect the combine engine cooling system by using Summer Engine Coolant Conditioner.

The Summer Engine Coolant Conditioner is available under Part No. T19566, and may be purchased from your John Deere dealer.

To install the Summer Engine Coolant Conditioner, perform the following:

Drain and flush cooling system and add two 32-ounce cans of Summer Engine Coolant Conditioner to the cooling system following directions on the container.

**IMPORTANT: Summer Engine Coolant Conditioner is NOT AN ANTIFREEZE or a cooling system sealer. Drain system and fill with recommended antifreeze solution as required for winter protection. When antifreeze solution is in system, it should not be necessary to use the conditioner; however, should severely corrosive water conditions be present, the conditioner is compatible with antifreeze solutions.**

## OPERATING THE ENGINE

### ENGINE INSTRUMENTS AND CONTROLS

#### Choke (Gasoline Engine only)



X 2228

Pull choke control all the way out when starting engine. After engine is started, and for normal operation, push choke control all the way in.

#### Throttle

Move throttle one quarter forward when starting engine. Move throttle all the way forward for normal operation; move throttle all the way rearward for slow idle.

#### Key Switch

Turn the key to "ON" to check the operation of the alternator indicator light. It should glow red.

Turn the key to "START" and hold until engine starts.

Release the key when the engine starts. The alternator indicator light should go out.

If the light does not go out after 10 seconds, shut off engine at once and determine the cause.

If the engine fails to start, refer to the trouble shooting charts on page 146.

**IMPORTANT: When starting the engine, never hold the key in start position for more than 30 seconds at a time. If the engine does not start within 30 seconds, allow at least 2 minutes for proper cooling of the starter. Be sure to pause a few seconds after a false start to make certain that the starter has stopped completely before another start is attempted.**

#### Alternator Indicator Light

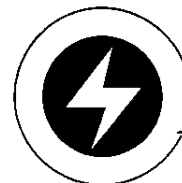

GLOWS RED IF  
ALTERNATOR IS  
NOT CHARGING

X 2229

This light glows red when the alternator is not charging. If the light goes on while the engine is running, stop engine and determine cause.

Check the operation of this light by turning the key to the "ON" position.

### Coolant Temperature Gauge

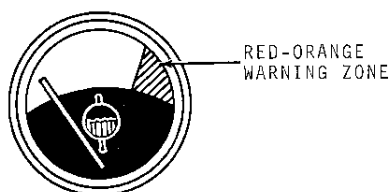

X 2231

This gauge indicates the coolant temperature in the cooling system—not the quantity. The white zone on the dial indicates normal operating temperature; the red-orange zone indicates above normal operating temperature.

If the pointer on the gauge goes into the red-orange zone, stop the engine and determine the cause.

### Coolant Temperature Warning Horn

The low note horn sounds when the coolant temperature gauge registers "HOT" or when the straw walker sensing unit (attachment) is activated.

If the horn sounds, stop the engine. If the straw walkers are not plugged, check the engine to determine the cause of overheating.

### Engine Oil Pressure Gauge

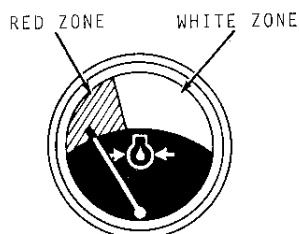

X 2232

This gauge indicates the pressure of the engine lubricating oil—not the amount of oil in the crankcase. Oil pressure will vary slightly with wear, but with recommended oil, it should read **NORMAL** at full governed speed (indicated by white zone on the dial). If oil pressure drops (indicated by red zone on the dial), stop immediately and determine the cause.

### Fuel Gauge

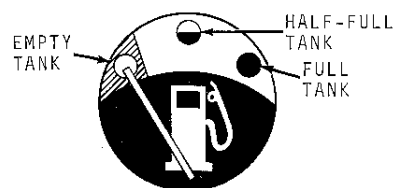

X 2233

The red-orange zone indicates that the tank is empty. A half-full mark and a full mark indicates the fuel level in the tank.

### Engine Tach-Hour Meter

The tach-hour meter shows the engine speed in hundreds of rpm and accumulated engine service in hours and tenths of hours (based on an average engine operating speed of 2500 rpm). Use this hour meter to determine when lubrication and periodic services are needed.

### Air Restriction Indicator (Attachment)

The red signal in the restriction indicator is locked in view whenever the air cleaner element is dirty and needs servicing. Check the indicator every 10 hours and if necessary service the element (page 133).

## STARTING THE DIESEL ENGINE

1. If the engine has not been operated for a long period of time, or if the fuel tank has run dry, bleed the entire fuel system to remove air bubbles (page 122).

**IMPORTANT: Never let the fuel tank run dry.**

2. If starting in cold weather, see "Cold Weather Operation," page 7.

3. Disengage platform or corn head electromagnetic clutch switch, separator control lever, and grain tank unloading auger lever.

4. Place gearshift lever in neutral.

5. Depress clutch pedal fully.

6. Move throttle lever one-quarter open.

7. Turn key to "ON." Check the operation of the alternator indicator light. It should glow red.

8. Turn key to "START." After the engine starts, release the key.

**IMPORTANT: When starting the engine, never hold the key in start position for more than 30 seconds at a time. If the engine does not start within 30 seconds, allow at least 2 minutes for proper cooling of the starter. Be sure to pause a few seconds after a false start to make certain that the starter has stopped completely before another start is attempted.**

If engine fails to start, see TROUBLE SHOOTING, page 146.

9. Make certain the oil pressure gauge registers pressure, and the alternator indicator light goes off. If not, stop engine and determine the cause.

10. Warm the engine and transmission for 5 minutes at slow idle—no load.

11. For the first 30 minutes, the combine should be operated at 25% slower ground speed. Engine must be operated at full throttle to maintain correct separator speed.

## STOPPING THE DIESEL ENGINE

1. Set the throttle at medium idle speed and allow the engine to run at this speed until the temperature gauge drops well into the white range on dial. Move the throttle to the rear and turn key to "OFF."

**IMPORTANT: Do not attempt to stop engine by turning off fuel supply at tank. Doing so will cause injection pump to run dry and damage internal parts.**

2. After stopping the engine, remove the key from the switch to prevent tampering and unauthorized operation. Removing the key also prevents the switch from being accidentally left in the "on" or the "accessory" position and causing battery discharge.

## STARTING THE GASOLINE ENGINE

1. If starting in cold weather, see "Cold Weather Operation," page 7.

2. Disengage platform or corn head electromagnetic clutch switch, separator control lever, and grain tank unloading auger lever.

3. Place gearshift lever in neutral.

4. Depress clutch pedal fully.

5. Move throttle lever one-quarter open.

6. Pull the choke control up.

7. Turn key to "ON." Check the operation of the alternator indicator light. It should glow red.

8. Turn key to "START." After engine starts, release key and push the choke control in.

**IMPORTANT: When starting the engine, never hold the key in start position for more than 30 seconds at a time. If the engine does not start within 30 seconds, allow at least 2 minutes for proper cooling of the starter. Be sure to pause a few seconds after a false start to make certain that the starter has stopped completely before another start is attempted.**

If the engine fails to start, see TROUBLE SHOOTING, page 146.

9. Make certain the oil pressure gauge registers pressure and the alternator indicator light goes off. If not, stop engine and determine the cause.

10. Warm the engine and transmission for 5 minutes at slow idle—no load.

11. For the first 30 minutes, the combine should be operated at 25% slower ground speed. Engine must be operated at full throttle to maintain correct separator speed.

## STOPPING THE GASOLINE ENGINE

1. Set the throttle at medium idle speed and allow the engine to run at this speed for a few minutes before stopping. Turn key to "OFF."

2. After stopping the engine, remove the key from the switch to prevent tampering and unauthorized operation. Removing the key also prevents the switch from being accidentally left in the "on" or the "accessory" position and causing battery discharge.

## OPERATOR'S PLATFORM COMPONENTS AIR CONDITIONER SYSTEM (Attachment)

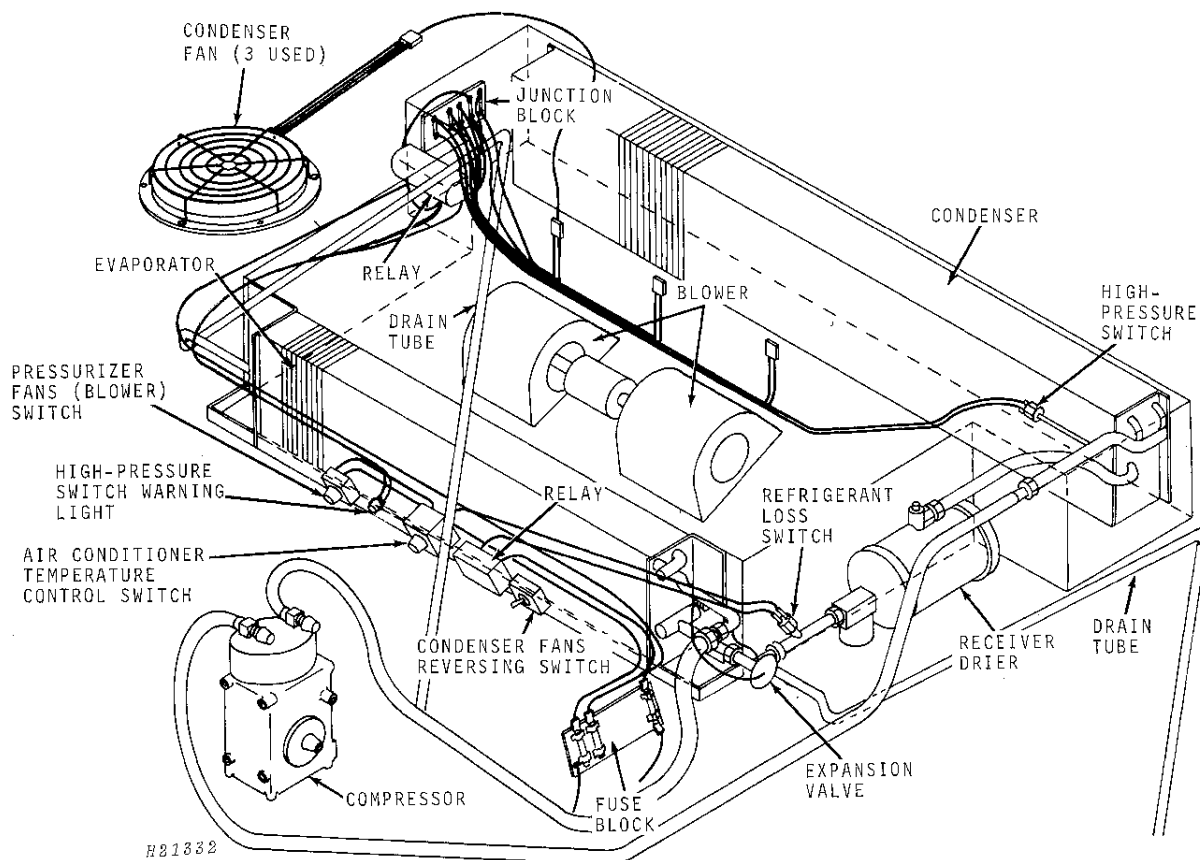

The air conditioner system consists of a compressor, condenser, condenser fans, receiver-drier, expansion valve, evaporator, high-pressure and refrigerant-loss switches, hoses, and a thermostatic-type control switch.

The air conditioner is operated by a thermostatic-type switch which can be adjusted for a definite cooling range since it is hooked to the evaporator.

The refrigerant comes into the compressor as a low-pressure gas, is compressed, and moves out of the compressor as a high-pressure gas. It then flows to the condenser where the gas condenses to a liquid, giving off its heat to the outside air through the condenser fans. The high-pressure liquid moves to the receiver-drier where a drying agent removes moisture from the liquid. The receiver-drier also stores a quantity of refrigerant to increase capacity of the system. The high-pressure liquid moves to the expansion valve which restricts liquid flow, thus lowering its pressure. The low-

pressure liquid moves to the evaporator where heat from inside the cab moves into the low-pressure liquid, changing the liquid to a low-pressure gas. This low-pressure gas returns to the compressor where the cycle is repeated.

**IMPORTANT: The condenser fans in the cab roof must be operating when the air conditioner is operating.**

The three condenser fans in the cab roof pull air through the condenser and moves this air out the cab roof. If the efficiency of the condenser is impaired due to dirt or chaff build-up, the fans can be reversed by operating the reversing switch (page 4) to clean the condenser core.

**IMPORTANT: Operate the reversing switch once every grain tank load for approximately 30 seconds to clean the condenser core.**

**IMPORTANT: The pressurizer system must be in operation when the air conditioner is in use.**

### AIR CONDITIONER SYSTEM— Continued

An optional 10-inch extended service condenser is available for use in severe field conditions.

Combines equipped with the 10-inch condenser require additional refrigerant to charge the system. The system capacity of air conditioners with the regular 6-inch condenser requires 60 ounces (four 15 ounce cans) of refrigerant 12. Air conditioners with the 10-inch condenser require 75 ounces (five 15 ounce cans) of refrigerant 12 to completely charge the system.

**CAUTION:** Air conditioner refrigerant is very dangerous when not handled properly. The air conditioner system should only be serviced by a qualified serviceman.

#### High-Pressure Switch

The high-pressure switch is used in conjunction with a relay to prevent the compressor electromagnetic clutch from recycling when a head pressure of 400 psi or above is reached.

Indications that the high-pressure switch has been activated are as follows:

1. Pressurizer and condenser fans are working but not cooling.
2. High-pressure switch warning light glows red.

To reactivate the system after the high-pressure switch has been activated, turn the pressurizer fan switch off and then on. If, after a short time, the high-pressure switch is again activated, the condenser needs to be cleaned. See page 136.

#### High-Pressure Switch Warning Light

This light warns the operator that the high-pressure switch has activated as described above.

#### Refrigerant-Loss Switch

The refrigerant-loss switch senses low pressure in the air conditioner system caused by loss of refrigerant or when operating in temperatures below 25°F. When the refrigerant-loss switch activates, the entire air conditioner system is inoperative.

See your John Deere dealer and have him charge the system.

#### Maximum Air Recirculator

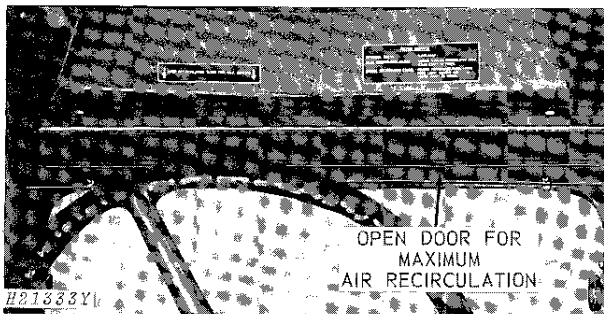

Under normal operating conditions, the normal air recirculator will provide sufficient cooling.

In those conditions which require increased cooling, open the door on the maximum air recirculator at the rear of cab.

#### HEATER SYSTEM (Attachment)

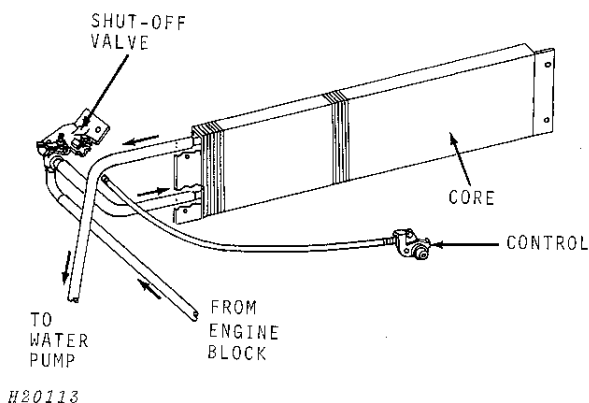

The heater system is composed of a core, a mechanical shut-off valve, hoses, and a control.

With the control knob on, the shut-off valve allows coolant from the engine block to enter, the shut-off valve directs the coolant to the lower tube of the core, and the water moves through the core out the upper tube on the core to the water pump.

The pressurizer fans blow across the heater core as the coolant moves through the heater, removing heat and blowing it through the louvered air outlets into the cab.

**IMPORTANT:** The pressurizer system must be in operation when the heater is in use.

## PRESSURIZER SYSTEM

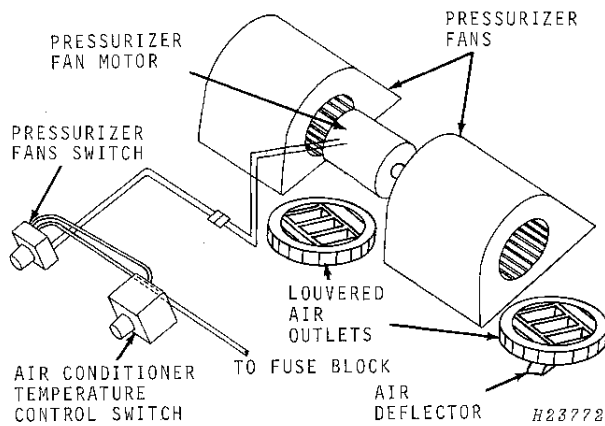

The pressurizer system is made up of two rotating cage-type fans, an electric motor, two louvered air outlets, an air deflector (snapped into one of the air outlets) and a control switch.

The pressurizer fans, when activated by the control switch, increase the pressure inside the cab. With a higher pressure inside the cab, the air and dust will not move from outside the cab to the inside of cab.

The louvered air outlets are also used to direct air flow from the air conditioner and heater.

**IMPORTANT: The pressurizer system must be in operation when the air conditioner or heater is in use.**

## OPERATOR'S SEAT

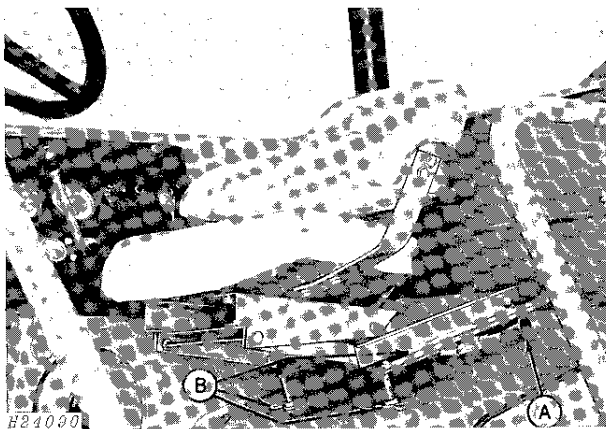

*Seat in Sitting Position*

The operator's seat moves forward and rearward or up and down to accommodate individual height and allows greater accessibility to all controls. If the operator wishes to stand, the seat can be positioned out of the way to allow ample leg space.

Use only warm water and mild soap to clean the seat cushions. NEVER USE SOLVENTS.

### Positioning the Seat Forward or Rearward

While sitting in the seat, push lever "A" forward as far as possible and, by using your weight, adjust seat to desired position. Then release lever "A."

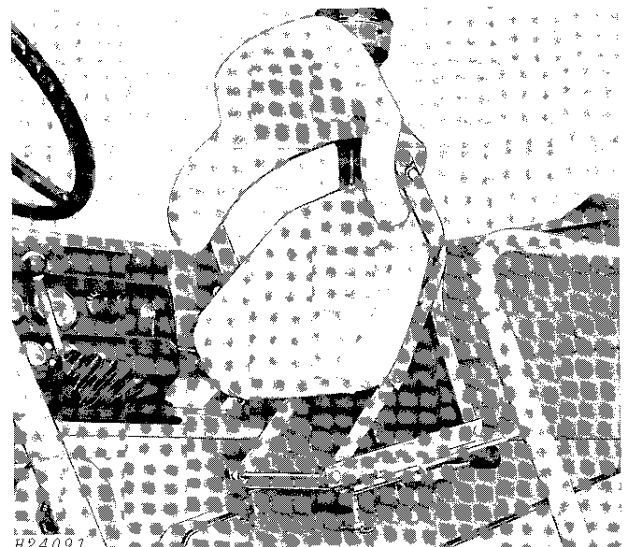

*Seat in Standing Position*

### Positioning the Seat Up or Down

Remove four spring locking pins "B." Raise or lower the seat to the desired height. Reinsert spring locking pins "B."

### Positioning the Seat for Standing

To move the seat up and back, stand up and apply pressure to the front of the seat with the back of your legs. The seat will move to the up and back position to allow standing room.

To return the seat to the sitting position, move the seat forward by pulling on the front of the seat with your hand.

### STEERING COLUMN

The steering column is adjustable to one of four positions for individual arm lengths. This allows better visibility and greater accessibility to the steering wheel and controls on the steering column.

#### Steering Column Control

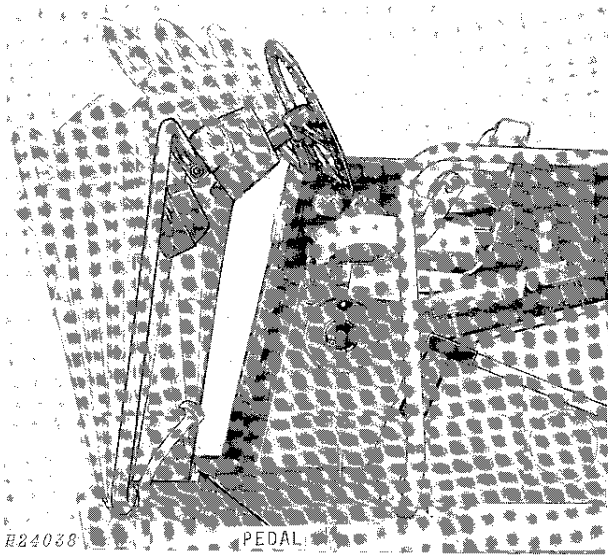

To adjust steering column push pedal down, position column to desired setting, and release pedal.

The world's best safety device is a careful operator.

### PIVOTING LADDER

Move the pivoting ladder up out of the way of uncut crop to avoid crop loss by ladder impact.

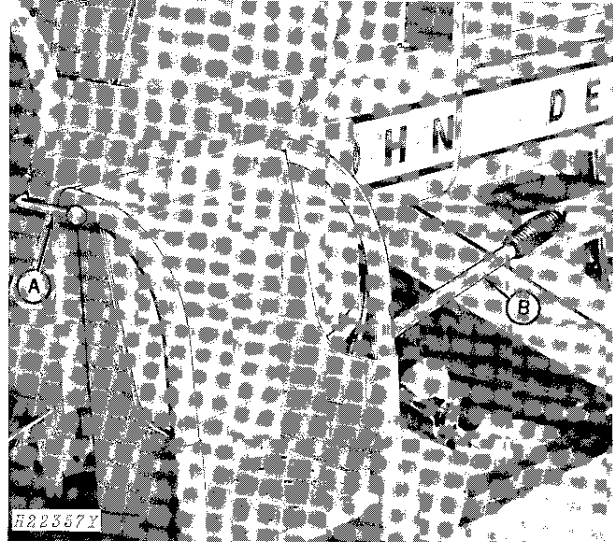

To move ladder, pull lever "A" up and to the right to release the lock.

Pull lever "B" forward until the ladder is parallel to the ground.

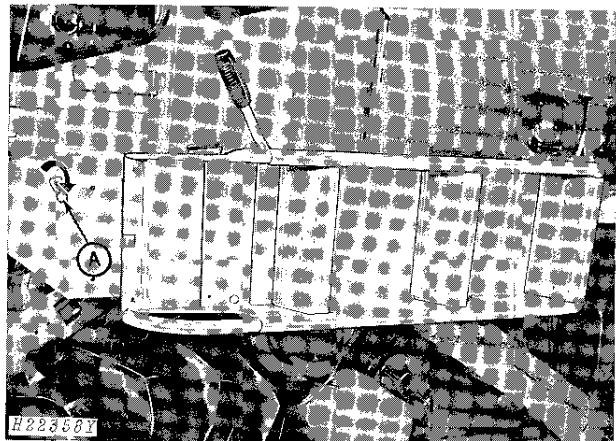

Push lever "A" to the left and down to lock ladder in place.

To lower the ladder, reverse the above procedure.

## LOW SHAFT SPEED MONITOR SYSTEM (Attachment)

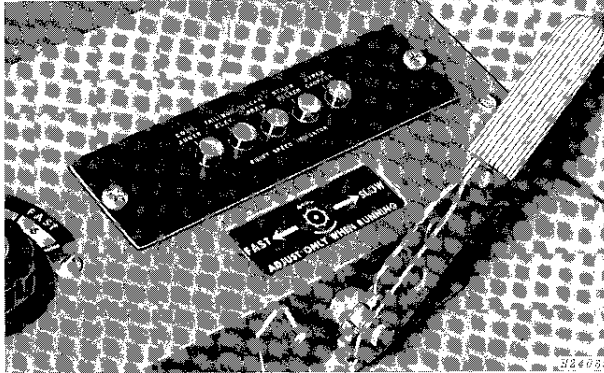

The low shaft speed indicator attachment indicates with glowing lights when the conveyor augers, tailings elevator, clean grain elevator, straw walkers, and straw chopper (combine attachment) drive shafts are operating less than 70 percent of their designed speed.

### Checking Indicator Operation

To check the operation of the low shaft speed indicator, turn key to "ON" (do not start engine) and engage separator lever; all lights should glow.

Disengage separator lever before starting engine.

### Operating Indicator

Start engine, engage separator lever, and run engine at fast idle. If lights continue to glow during operation, disengage separator lever and idle engine. Shut off engine and check Trouble Shooting chart on page 155.

**CAUTION:** Be certain combine engine is shut off before working on combine.

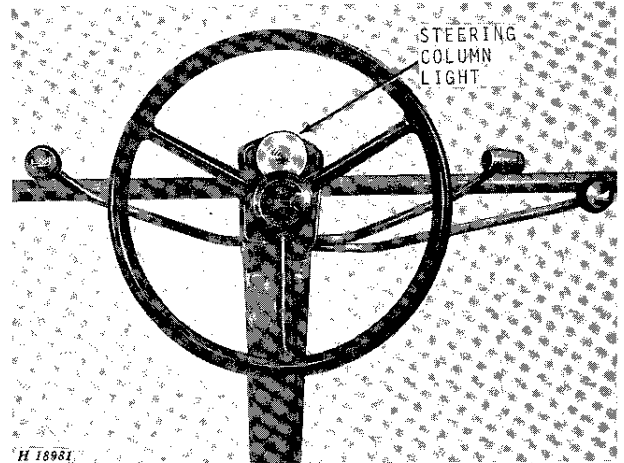

When a light on the control box glows, the light on the steering column flashes.

### Control Switch

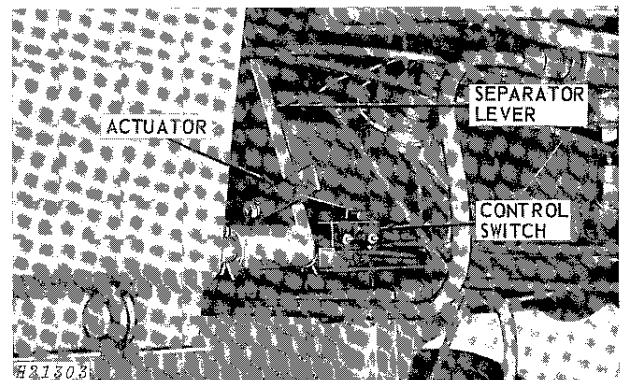

A control switch, located under the operator's platform, prevents the lights from glowing before the separator lever is engaged. Lights will glow until separator is brought up to full operating speed. If lights continue to glow, see Trouble Shooting chart on page 155.

### Sensor Locations

The locations of the five sensors are shown in the following illustrations.

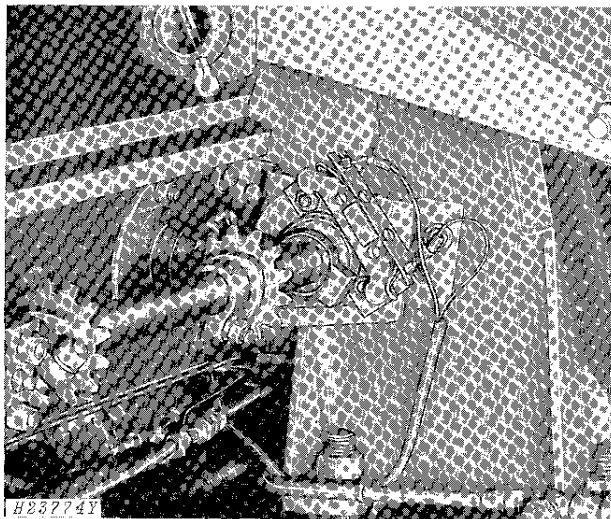

*Conveyor Augers*

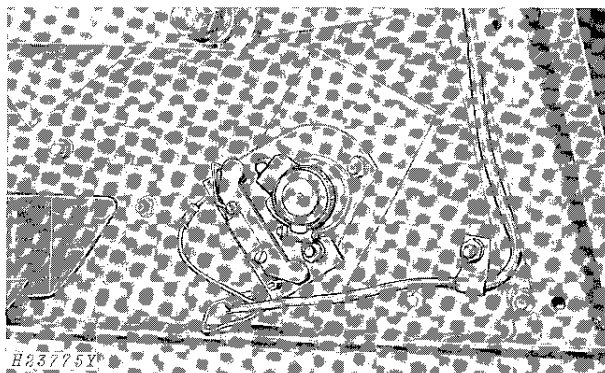

*Clean Grain Elevator*

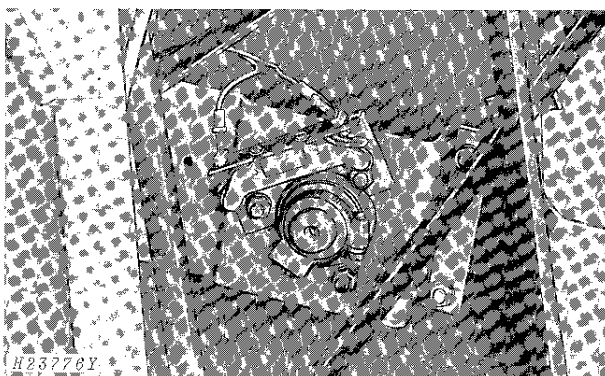

*Straw Walker*

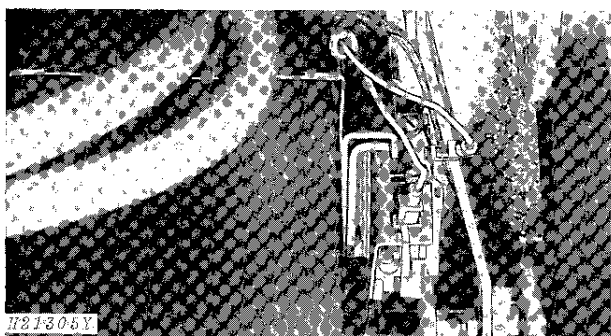

*Tailings Elevator*

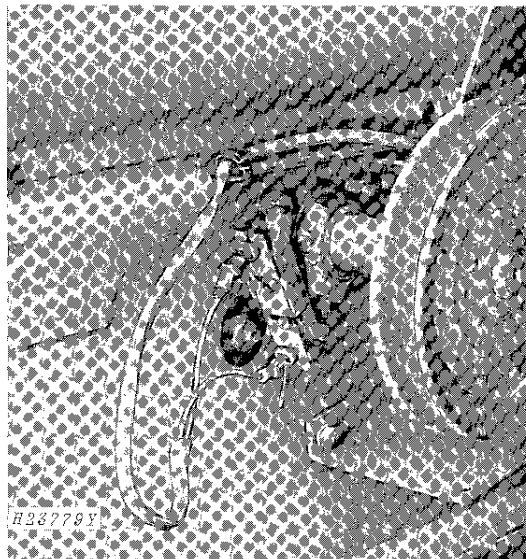

*Straw Chopper*



**Suggest:**

**If the above button click is invalid.**

**Please download this document**

**first, and then click the above link**

**to download the complete manual.**

**Thank you so much for reading**

## TRANSPORTING

The combine can be transported by driving it under its own power, carrying it on a truck, or by towing. When towing combine, remove the drive shafts between final drives and differential. Use caution when towing.

 **CAUTION: If towed at higher speeds, remove the drive shafts and lock the brake drums in place by applying the parking brake.**

Higher speeds will cause oil to flow out of breather plugs in final drives. Check oil level before operating.

When applying brakes during transporting, be certain equal pressure is applied to both pedals.

Reduce the width of the combine by folding the unloading auger back along the separator and removing the platform or corn head. Over-all dimensions are given on page 170.

The rotary screen, fender and vacuum duct may be removed for narrower transport width. An optional bracket is available for attaching the rotary screen to the separator body during transport or storage.

If the platform or corn head and feeder house are removed, the hydraulic cylinders must be wired or supported by chains no closer to separator support channel than 14 inches. Damage may result to hoses if carried too close.

If the platform or corn head is left on, raise platform or corn head to a position allowing good visibility.

Reduce the spread of noxious weed seeds by thoroughly cleaning the combine before leaving one field and going to the next.

Sweep trash and straw from the outside of combine. Open doors at bottom of elevators, remove—grain tank drain hole cover, and run combine until all straw, trash, and grain are removed from inside. Shut off combine engine. Clean out shoe grain supply augers (page 84).

The combine is equipped with a slow moving vehicle emblem on the rear hood, lights, grain tank reflectors, and red reflective tape on the backside of the platform or corn head for transporting protection. Keep the emblem, reflectors, and lights clean.

 **CAUTION: When driving the combine on a road or highway at night or during the day, use lights and devices provided for adequate warning to the operators of other vehicles. In this regard, check local governmental regulations.**

On combines not equipped with the turn signal attachment, when flashing warning lamps are prohibited, the operator must replace AU41465 flasher with AR41694 plug. In this regard, check local regulations.

**<https://www.ebooklibonline.com>**

Hello dear friend!

Thank you very much for reading.

Enter the link into your browser.

The full manual is available for immediate download.

**<https://www.ebooklibonline.com>**