

JOHN DEERE 2350 AND 2550 TRACTORS



JOHN DEERE

OPERATORS MANUAL JOHN DEERE 2350 AND 2550 TRACTORS

OML55481 L4 English

JOHN DEERE WERKE MANNHEIM
OML55481 L4

LITHO IN THE U.S.A. (REVISED)
ENGLISH

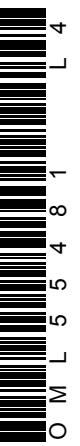



Read this manual carefully to learn how to operate and service your machine correctly.

SAFETY



CAUTION: This safety alert symbol identifies important safety messages in this manual. When you see this symbol, be alert to the possibility of personal injury, and carefully read the message that follows.

DIRECTIONS

Left, right, front and rear in this manual are seen from the operator's seat facing the direction of forward travel.

MEASUREMENTS

This machine is of metric design.

For your convenience, most specifications are given in metric measurement with the customary U.S. measurement following.

Some specifications cannot be converted. These appear in metric only.

Most hardware is metric. Specified metric hardware must be used for replacement.



CAUTION: Use only metric tools. Other tools may not fit properly. They may slip and cause injury.

WARRANTY

The warranty on this machine appears on your copy of the purchase order which you should have received from your dealer when making your purchase. This warranty provides you the assurance that John Deere will back its products where defects appear within the warranty period. In some circumstances, John Deere also provides field improvements, often without charge to the customer, even if the product is out of warranty.

Warranty and field improvements are a part of John Deere's product support program for customers who operate and maintain their equipment as described in this manual. Should the equipment be abused, or modified to change its performance beyond the original factory specifications, the warranty will become void and field improvements may be denied. Setting fuel delivery above specifications or otherwise overpowering machines will result in such action.

MACHINE NUMBERS

Write your product identification number (PIN) and serial numbers on the pages provided at the end of this manual, and provide this information to your dealer when ordering spare parts.

Identification Views

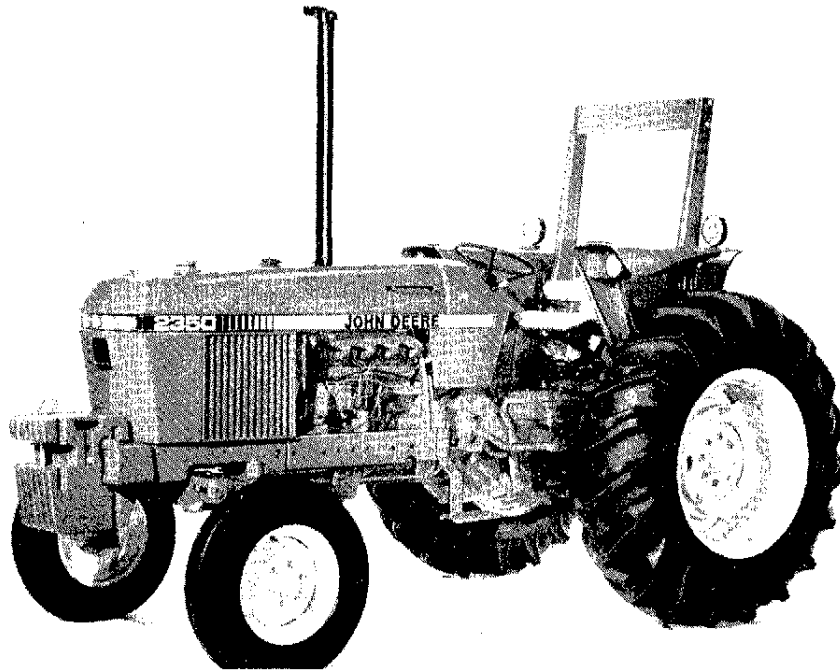

L100 001A



L104 642

L100001A,L104842-2350ALE-081183

<https://www.ebooklibonline.com>

Hello dear friend!

Thank you very much for reading.

Enter the link into your browser.

The full manual is available for immediate download.

<https://www.ebooklibonline.com>

Contents

Index	00-	Operator's Station	30-
– Index	00-5	– Lighting system	30-1
Safety	05-	– Seats	30-3
– Safety	05-1	– Roll guard	30-5
Crime Prevention Tips	05-	– Seat belt	30-5
– Crime prevention tips	05-9	– Windshield wipers	30-6
Controls and Instruments	10-	– Fan, air louvers, heater	30-6
– Controls	10-1	– Air conditioning system	30-6
– Control lights	10-2	– Steering wheel adjustment	30-7
– Instruments	10-3	Treads, Tires, Ballast	35-
Break-In Period	15-	Wheel treads	35-1
– After the first 4 and 8 hours	15-1	– Adjusting front wheel tread	35-2
– After the first 50 hours	15-1	– Checking front wheel toe-in	35-3
– After the first 100 hours	15-2	– Adjusting front wheel toe-in	35-3
– Within the first 100 hours	15-2	– Rear wheel tread adjustment	35-4
Operating the Engine	20-	Tires	35-10
– Prestarting check	20-1	– Tire pressures	35-10
– Starting the engine	20-2	– Servicing tires	35-10
– Thermostat aid	20-3	Ballast	35-11
– Ether starting aid	20-4	– Measuring rear wheel slip	35-12
– Starting with a booster battery	20-6	– Rear wheel weights	35-12
– Towing the tractor to start	20-7	– Installing rear wheel weights	35-13
– Towing the tractor	20-7	– Filling tires with liquid ballast	35-14
– Parking the tractor	20-8	– Front weights	35-15
– Stopping the engine	20-8	Rockshaft, Three-Point Hitch	40-
Operating the Tractor	25-	Rockshaft	40-1
Reduce fuel consumption	25-1	– Control lever	40-1
Ground travel speeds	25-3	– Load selector lever	40-3
– At desired engine speed	25-3	– Rate-of-implement drop	40-4
– At rated engine speed	25-4	Three-point hitch	40-5
Operating the tractor	25-6	– Draft links	40-5
– Shifting gears	25-6	– Center link	40-7
– Hi-Lo shift unit	25-7	– Lift links	40-7
– Creeper transmission	25-7	– Attaching implements	40-8
– Differential lock	25-8	– Positioning sway blocks	40-9
– Foot brakes	25-9	Accessories	45-
		Selective control valves	45-1
		– Tractors without SOUND-GARD body	45-1
		– Tractors with SOUND-GARD body	45-5
		– Breakaway couplers	45-7
		– Maximum permissible oil withdrawal	45-9
		Double acting remote hydraulic cylinder	45-10
		Swinging drawbar	45-11

Contents

Power Take-Off	50-	Service-Clutch	85-
– PTO guard	50-1	– Adjusting clutch	85-1
– Operation of PTO (continuous-running)	50-2	– Adding fluid to clutch reservoir	85-2
– Operation of independent PTO	50-2		
– Attaching PTO driven equipment	50-3	Service-Engine	90-
		– Engine oil	90-1
Front-Wheel Drive	55-	– Engine filter	90-2
– Operation	55-1	– Alternator V-belt	90-2
– Front wheel steering angle	55-2	– Engine speeds	90-2
– Adjusting front wheel tread	55-3		
– Tires	55-6	Service-Cooling System	95-
		– Checking coolant level	95-1
Fuel, Lubricants, Coolant	60-	– Replacing coolant	95-2
Fuel	60-1		
– Fuel specifications	60-1	Service-Axles and Wheels	100-
– Fuel storage	60-1	– Lubricating front axle	100-1
Lubricants	60-2	– Lubricating drive housings and shafts	100-2
– Fluid for hydraulically operated clutch	60-2	– Lubricating rear axles	100-2
– Engine oil	60-2	– Checking front axle oil level	100-3
– Transmission/hydraulic oil	60-3	– Changing front axle oil	100-4
– Transmission oil for MFWD front axle	60-3		
– Multipurpose grease	60-4	Service-Fuel System	105-
Engine coolant	60-4	– Checking fuel filter	105-1
		– Replacing fuel filter	105-2
Removing Access Covers	65-	– Draining water trap	105-2
– Hood	65-1	– Bleeding fuel system	105-3
– Grille screens	65-1		
– Battery box covers	65-1	Service-Transmission/Hydraulic	110-
		– Checking oil level	110-1
Lubrication and Periodic Service	70-	– Replacing filter element	110-1
– Service intervals	70-1	– Changing oil	110-2
– Time table	70-2	– Replacing steering filter	110-2
Service-Air Intake System	75-	Service-Miscellaneous	115-
– Primary air filter	75-1	– Operator's seat	115-1
– Secondary air filter	75-2	– 3-Point hitch	115-1
– Dust unloading valve	75-3	– SGB-air filter	115-2
– Air intake hoses	75-3		
Service-Brakes	80-		
– Bleeding brakes	80-1		
– Adjusting handbrake	80-1		

Contents

Service-Electrical System	120-	Trouble Shooting	135-
- Batteries	120-1	- Hydraulic system	135-1
- Checking specific gravity	120-1	- Engine	135-2
- Level of electrolyte	120-2	- Electrical system	135-3
- Removing batteries	120-2		
- Starting motor	120-4	Specifications	140-
- Neutral start system	120-4	- Engine	140-1
- Alternator	120-5	- Weights	140-2
- Lamps	120-6	- Electrical system	140-3
- Circuit breaker	120-7	- Capacities	140-3
Service-Heater and Air Conditioning System .	125-	Serial Numbers	145-
- Air conditioning system	125-1	- Serial numbers	145-1
- Heater	125-2		
Tractor Storage	130-	Maintenance Record	150-
- Storage	130-1	- Maintenance record	150-1
- Removing tractor from storage	130-2		

Index

A

Adjustable front axle	35-1
Adjusting front wheel toe-in	35-3
Adjusting front wheel tread	35-2
Air cleaner indicator light	10-2
Air conditioning system	30-6
Alternator	120-5
Alternator indicator light	10-2

B

Ballast	35-11
Batteries	120-1
Bleeding brakes	80-1
Bleeding fuel system	105-3
Breakaway couplers	45-7
Break-in period	15-1

C

Circuit protection	120-7
Checking front wheel toe-in	35-3
Checking wheel retaining bolts	15-1
Clutch pedal adjustment	85-1
Cold weather starting aids	20-2
Coolant temperature gauge	10-3
Cooling system	95-1
Controls	10-1
Creeper transmission	25-7
Control lights	10-2

D

Differential lock	25-8
Drawbar	45-11
Double-acting remote hydraulic cylinder	45-10

E

Electrical system	120-1
Engine coolant	60-4
Engine oil	60-2
Engine speeds	90-2
Engine warm-up period	20-7

F

Filling tires with liquid ballast	35-14
Fluid for hydraulically operated clutch	60-2
Front wheel drive	55-1
Front wheel steering angle	55-2
Fuel, lubricants and coolant	60-1
Fuel filter	105-1
Fuel gauge	10-3
Fuel system	105-1

G

Grease	60-4
Ground travel speeds	25-3

H

Handbrake adjustment	80-1
Heater and air conditioning system	30-6
Hi-beam indicator light	10-2
Hi-Lo shift unit	25-7
Hydraulic foot brakes	25-9
Hydraulic operated clutch	85-1

I, L

Identification views	00-1
Instruments	10-3
Lighting system	30-1
Lubricants	60-2
Lubrication and maintenance records	150-1
Lubrication and periodic service	70-1

Index

M

Maximum permissible oil withdrawal 45-9
Measuring rear wheel slip 35-12
Mechanical front wheel drive, oil 55-1

O

Oil pressure indicator light, engine 10-2
Oil pressure indicator light, transmission 10-2
Opening windows 30-5
Operating the engine 20-1
Operating the tractor 25-6
Operator's seats 30-3
Operator's station 30-1

P

Parking the tractor 20-8
Periodic service timetable 70-2
Power take-off 50-1

R

Rack-and-pinion axle 35-1
Range shift lever positions 25-6
Rear wheel treads 35-4
Remote hydraulic cylinder 45-10
Removing tractor from storage 130-2
Rockshaft 40-1
Roll guard 30-5
Reduce fuel consumption 25-1
Reverser transmission 25-8

S

Safety rules 05-1
Seat belt 30-5
Selecting gears 25-6
Selecting travel speeds 25-3
Selective control valves 45-1
Serial numbers 145-1
Service 75-1
Shifting transmission 25-6
Specifications 140-1
Starting motor 120-4
Starting the engine 20-2
Stopping the engine 20-8
Storage, tractor 130-1
Steering wheel adjustment 30-7

T

Three-point hitch 40-5
Tires and tire pressures 35-10
Toe-in, front wheel 35-3
Towing the tractor to start 20-7
Towing the tractor 20-7
Transmission/hydraulic oil 60-3
Travel speeds 25-3
Tread adjustment 35-1
Trouble shooting 135-1

W

Warm-up period 20-7
Wheel treads 35-1
Windshield wipers 30-6

Safety

AVOID TRACTOR RUNAWAY

Avoid possible injury or death from a machine runaway.

Do not start engine by shorting across starting motor terminals. Machine will start in gear and move if normal starting circuitry is bypassed.

Start engine only from operator's seat with transmission in neutral. NEVER start engine while standing on the ground.

When servicing front-wheel drive tractor with rear wheels supported off ground and rotating wheels by engine power, always support front wheels in a similar manner. Loss of electrical power or transmission-hydraulic system pressure will engage front driving wheels, pulling rear wheels off support if front wheels are not raised. Under these conditions, the front-drive wheels can engage even with switch in disengaged position.

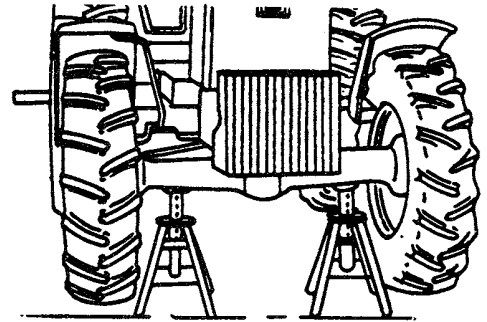

L 104 643

L104643-2350ALE-280284

USE PROTECTIVE EQUIPMENT PROPERLY

Use a seat belt under almost all operating conditions.

If SOUND-GARD body is loosened or removed for any reasons, make certain all parts are reinstalled correctly.

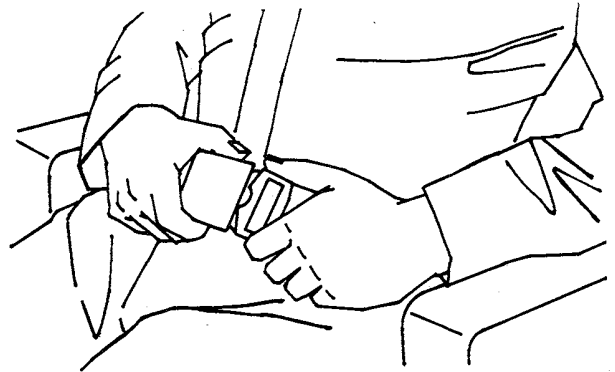

RW4419-2350ALE-091183

NOISE PROTECTION

Prolonged exposure to loud noise can cause impairment or loss of hearing.

Wear a suitable hearing protective device such as earmuffs (A) or earplugs (B) to protect against objectionable or uncomfortable loud noises.

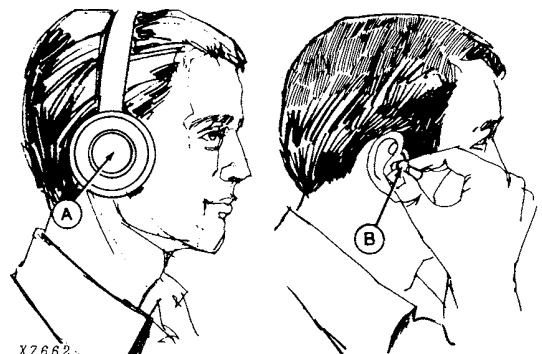

X7662

X7662-1065AZE-262081

SAFETY ON PUBLIC ROADS



CAUTION: Always comply with local traffic regulations when driving on public roads.

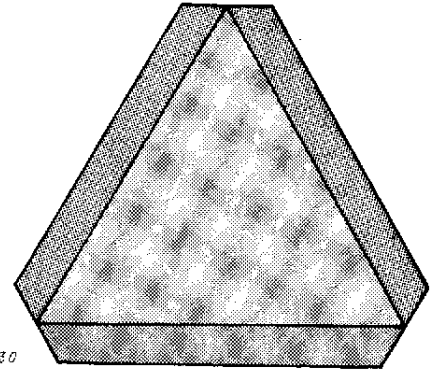

H28930

H28930-1065AZE-261081

HANDLE CHEMICALS PROPERLY

SOUND-GARD body air filters (A) are not designed to filter out harmful chemicals. Follow instructions given in implement operator's manual and those given by the chemical manufacturer when using agricultural chemicals.

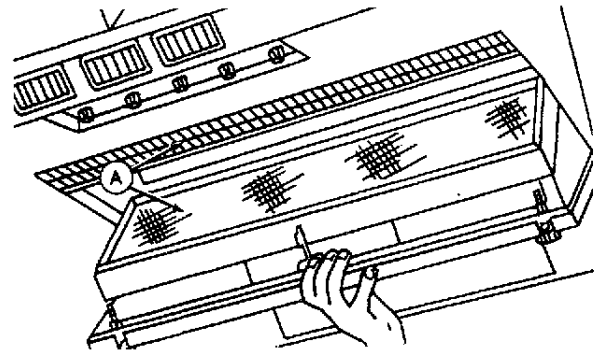

RW5704L-2350ALE-091183

AVOID EXPLOSIONS OR FIRE

Batteries produce explosive gas. Before using booster batteries, read the instructions listed under "Using a Booster Battery", in Operating the Engine section.

To avoid sparks, turn the charger off before connecting or disconnecting a battery charger.

Be careful with starting fluid or any type of fuel. Do not refuel the tractor when the engine is hot or running. Never smoke while handling fuel.

A fire extinguisher can be mounted on your tractor. It is available from your JOHN DEERE dealer. Be sure to read the owners manual packaged with the extinguisher for operation and service instructions.

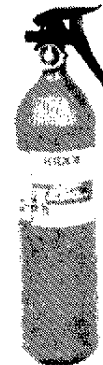

RW5985,RW2389-2350ALE-091183

EMERGENCY EXIT

For an emergency exit, SOUND-GARD® body windows can be opened. Remove the Quick-Lock pins (A) and headed pins (B) from window latches, and push window wide open.

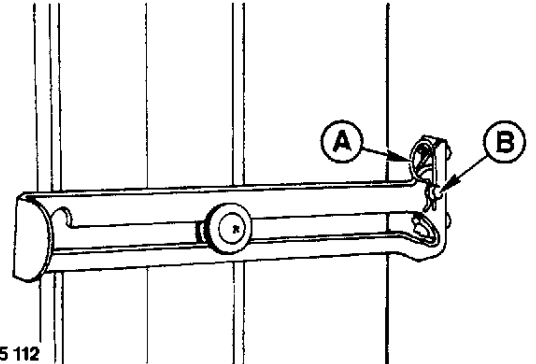

L 105 112

L105112-2350ALE-091183

OPERATING THE ENGINE

Before starting the engine make sure there is plenty of ventilation. Never operate the engine in a closed building. Danger of asphyxiation!

When starting the engine, rockshaft control lever must be in "lower" position.

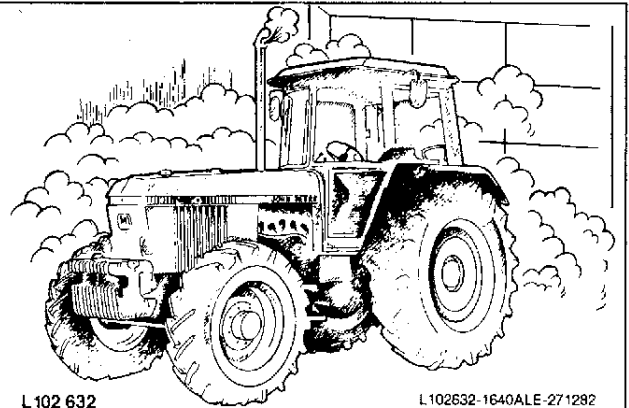

L 102 632

L102632-1640ALE-271292

DO NOT MODIFY TRACTOR

Unauthorized modification to the machine may impair the function and/or safety and effect machine life.

Never modify structural members of SOUND-GARD body or ROLL-GARD protective frame by welding, bending, drilling or cutting as this might weaken the structure. If any component is damaged, replace it. Do not attempt repairs.

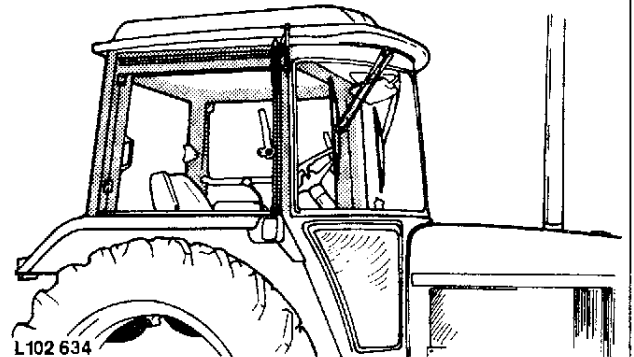

L102 634

L102634-2350ALE-091183

STAY CLEAR OF PTO

Stop the engine and be sure the PTO drive line (A) has stopped before:

- Connecting or disconnect implement drive line
- Making adjustments on the implement
- Cleaning out PTO driven equipment

PTO master shield (B) and drive lines should be in place at all times except for special applications as directed in the implement operator's manual.

The PTO shaft guard should be in place when the PTO is not being used.

Operate PTO at recommended speed.

Avoid loose-fitting or dangling clothing.

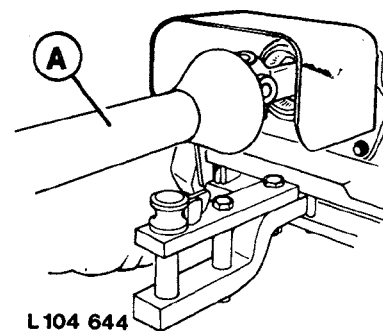

L104644-2350ALE-091183

TOW EQUIPMENT PROPERLY

Lock drawbar pin in place and use safety chain for towed equipment.

Use caution when towing loads at transport speeds. Reduce speed if towed load weighs more than the tractor and is not equipped with brakes. Avoid hard braking applications. Consult implement operator's manual for recommended transport speeds.

Use additional caution when transporting towed loads under adverse surface conditions, when turning or on inclines.

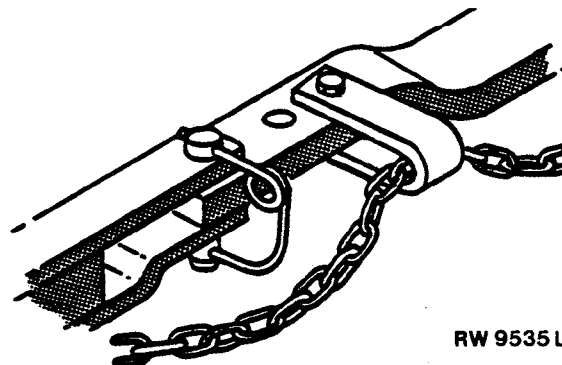

RW9535L-2350ALE-091183

STAY CLEAR OF MOVING TRACTOR

Be sure everyone is clear of tractor and attached equipment before starting engine. Some movement may occur as engine starts.

Never try to get on or off a moving tractor.

Before dismounting, place the transmission in neutral (A), apply handbrake (B) and lower implements to the ground. If tractor is to be left unattended, stop the engine and remove the key.

Never attempt to start or operate tractor except from operator's station.

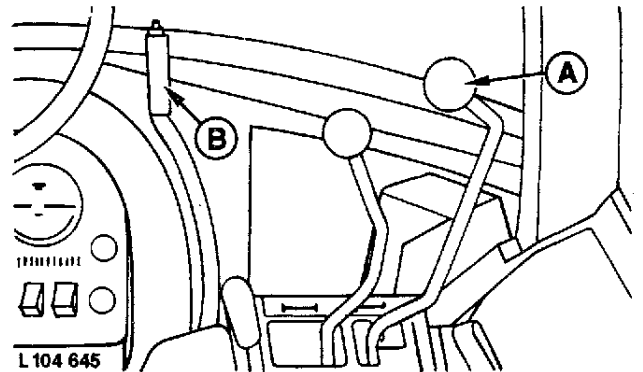

L104645-2350ALE-091183

OPERATE TRACTOR SAFELY

Never allow riders on the tractor.

Slow down for hillsides, rough ground, and sharp turns.

Couple the brake pedals together before driving at transport speeds.

When implements or attachments are used with the tractor, always follow safety precautions listed in implement operator's manual or operating instructions. When raising a heavy object with a loader, be sure the object is secure from falling. It could fall on and seriously injure a bystander or the operator.

Keep all shields in place.

Always apply handbrake before dismounting. Leaving transmission in gear with engine stopped will NOT prevent tractor from moving.

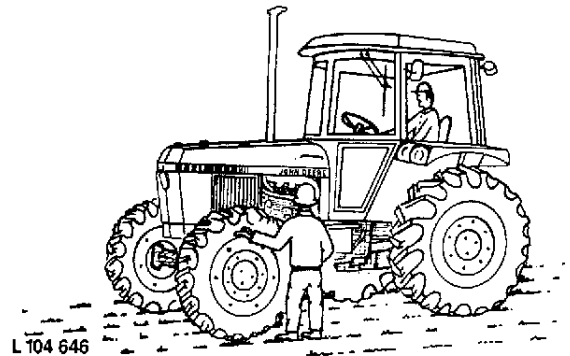

L104646-2350ALE-091183

AVOID TIP-OVERS

Avoid holes, ditches, and obstructions which may cause the tractor to tip – especially on hillsides.

Front-wheel drive (A) greatly increases traction. When this option is used, extra caution is needed on slopes. Compared to 2-wheel drive, a front-wheel drive tractor maintains traction on steeper slopes, increasing the possibility of a tip over.

Never drive near the edge of a gully or steep embankment – it might cave in.

Driving forward out of a ditch or mired condition or up a steep slope could cause tractor to tip over rearward. Back out of these situations if possible (B).

Be especially careful when using single wheels. Danger of overturn increases greatly with narrow 1.50 m (60 in.) tread at high speed.

Hitch towed loads only to drawbar. When using a chain, take up the slack slowly.

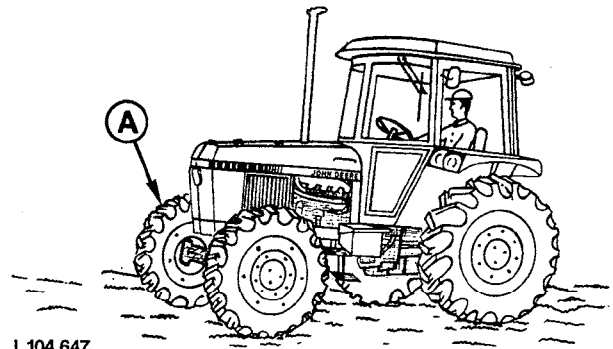

L 104 647

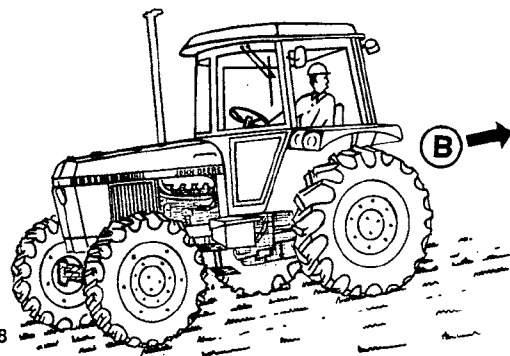

L 104 648

L104647,L104648-2350ALE-091183

TRANSPORT TRACTOR SAFELY

Before descending a steep hill (A), shift to a low gear (B) to control the tractor with little or no braking. Never coast downhill.

When transporting downhill on icy or graveled grades, be alert for skids which could result in loss of steering control. To decrease chance of skids, reduce speed and be sure tractor is properly ballasted. Engage front-wheel drive for four wheel braking.

Additional ballast may be needed for transporting heavy integral implements. When implement is raised, drive slowly over rough ground, regardless of how much ballast is used.

Never tow tractor faster than 8 km/h (5 mph). Before towing tractor, see instructions in Transporting section.

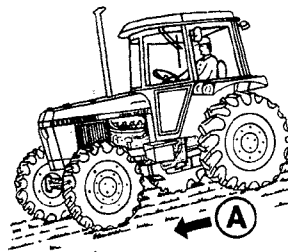

L 104 649

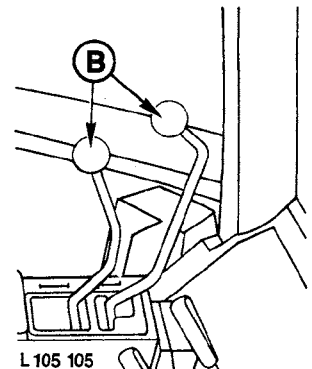

L 105 105

L104649,L105105-2350ALE-091183

MAKE TRACTOR VISIBLE ON HIGHWAY

Turn light switch to "H" position. Never use white lights which are visible from the rear. Always dim headlights properly adjusted. Add reflectors, and auxiliary lighting to equipment as required for safety and by local regulations. Before operating tractor on highway, be sure flashing warning lamps (A) work properly. Adjust rear view mirror (B), and clean windows.

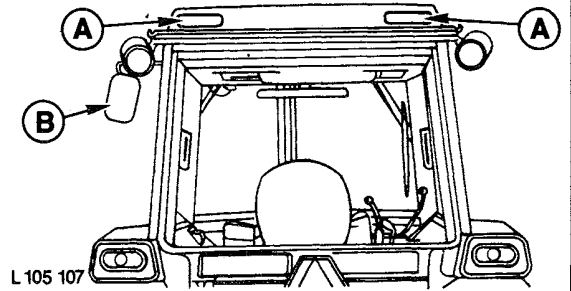

L105107-2350ALE-091183

SERVICE – GENERAL

Do not service the tractor while engine is running.

Reinstall all shields and guards removed for servicing and make sure they are in good condition.

Have adjustments carried out by trained personnel only.

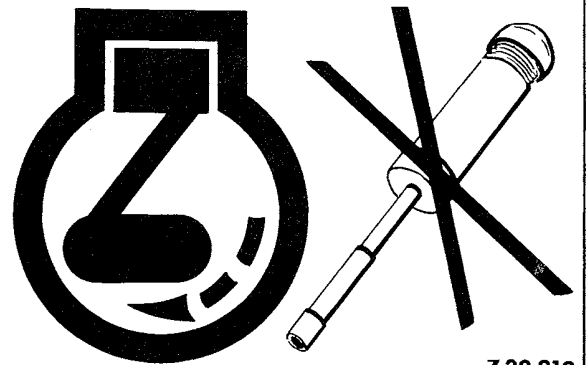

L20919-2350ALE-070384

AVOID HIGH-PRESSURE FLUIDS

Escaping fluid under pressure can penetrate the skin causing serious injury. Relieve pressure before disconnecting hydraulic or other lines. Tighten all connections before applying pressure. Keep hands and body away from pin holes and nozzles which eject fluids under high pressure. Use a piece of cardboard or paper to search for leaks. Do not use your hand.

If any fluid is injected into the skin, it must be surgically removed within a few hours by a doctor familiar with this type of injury or gangrene may result.

The air conditioning system is pressurized. Improper servicing may cause refrigerant to penetrate eyes and skin or cause burns. Special equipment and procedures are required to service air conditioning system. (See your JOHN DEERE dealer).

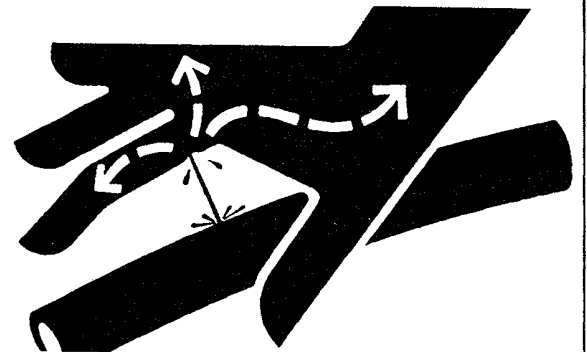

L102134-2350ALE-091183

SERVICE COOLING SYSTEM SAFELY

Do not remove radiator cap (A) when engine is hot. Shut the engine off and wait until it cools. Then turn the cap slowly to the first stop to relieve pressure before removing it completely.



L 105 108

L105108-2350ALE-091183

SERVICE TIRES SAFELY

Failure to follow proper procedures when mounting a tire on a wheel or rim can produce an explosion which may result in serious injury or death. Do not attempt to mount a tire unless you have the proper equipment and experience to perform the job. Have it done by your JOHN DEERE dealer or a qualified repair service.

When sealing tire beads on rims, never exceed 240 kPa (2.4 bar;35 psi) or maximum inflation pressures specified by tire manufacturers for mounting tires. Inflation beyond this maximum pressure may break the bead, or even the rim, with dangerous explosive force. If both beads are not seated when maximum recommended pressure is reached, deflate, reposition tire, relubricate bead and reinflate.

Detailed agricultural tire mounting instructions, including necessary safety precautions, are contained in JOHN DEERE Fundamentals of Service (FOS) Manual 55, Tires and Tracks, available through your JOHN DEERE dealer. Such information is also available from the Rubber Manufacturers Association and from tire manufacturers.

- A—Use a safety cage if available
- B—Do not stand over tire. Use a clip-on chuck and extension hose

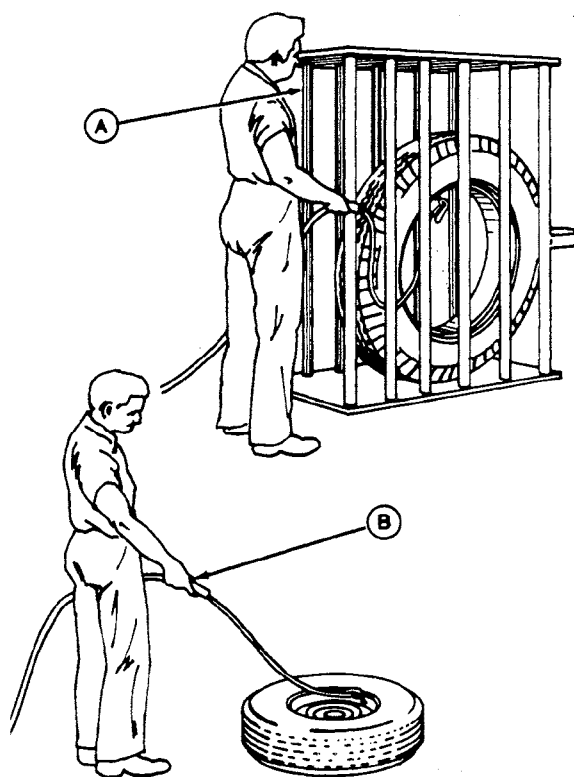

TSC123-2350ALE-280284

DISCONNECTING ELECTRICAL CIRCUIT

Disconnect battery ground strap before carrying out any electrical repairs on the tractor.

Keep all sparks and flames away from batteries, as gas given off by electrolyte is explosive. To avoid sparks, connect ground cable (A) last and disconnect it first. When using a booster battery, follow instructions in "Operating the Engine" section.

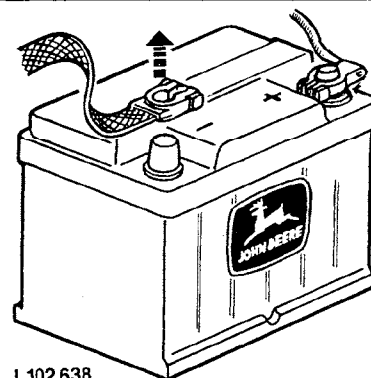

L 102 638

L102638-2350ALE-091183

Crime Prevention Tips

GOOD ADVICE

Keep your machine damage-free and YOURS!

Follow the advice on these pages to reduce vandalism, discourage theft, and help recover your machine if it is stolen.

TAKE A BITE OUT OF
CRIME

© 1979 The Advertising Council, Inc.



AB6;TS140 053;CRPRV A 181183

RECORD IDENTIFICATION NUMBERS

1. Record Product Identification Number (PIN) of unit and identification numbers of engine, component, attachment, etc. EXACTLY as they appear on the plates.
2. Check that the complete and correct numbers appear on all documentation (insurance, financial, warranty, manufacturer's certificate of origin, etc.). Keep all documents in a safe location.
3. If available, participate in an "Owner Applied Numbering Program" and mark your own machines.



AB6;TS161 053;CRPRV B 091283

MAINTAIN DOCUMENTED PROOF OF OWNERSHIP

1. Keep in a safe location all documents (invoices, warranty cards, manufacturer's certificate of origin, if available, etc.) that accompanied your machines at the time of purchase.
2. Take color photographs of each machine from several angles.
3. Maintain an up-to-date inventory of all machines. Check regularly to insure no machines have been stolen.

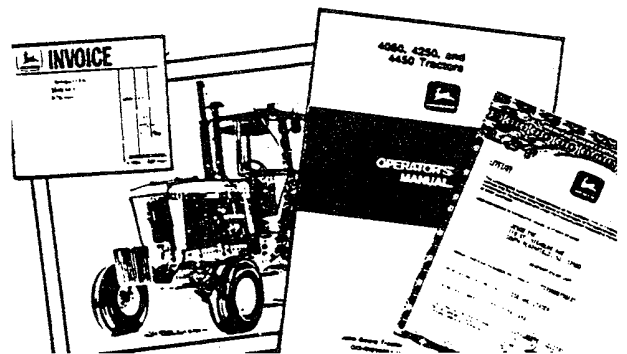

AB6;TS142 053;CRPRV C 181183

PARK INDOORS OUT OF SIGHT

1. Lower all equipment making the machine harder to move.
2. Remove ignition key. If so equipped, lock cab doors, windows and any vandal protection devices. Place hard-to-move equipment in front of exits.
3. If machine is being stored, remove the battery or any essential component in the electrical system.
4. Set wheels in widest position making loading more difficult. Secure all openings to storage buildings.

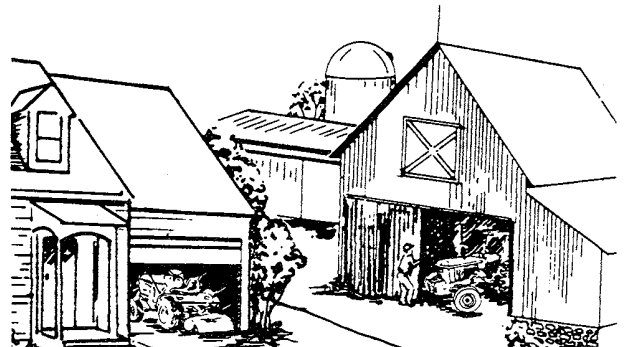

AB6;TS143 053;CRPRV D 100184

053;P01 A 181183



Suggest:

If the above button click is invalid.

Please download this document

first, and then click the above link

to download the complete manual.

Thank you so much for reading

PARKING OUTDOORS

1. Park machine in a fenced, well-lighted, locked area. Lower equipment, remove ignition key and lock cab doors, windows, and any vandal protection devices, if so equipped.
2. Make law enforcement aware of your presence in an area and provide them with a contact person to assist them in dealing with suspicious activity.
3. Solicit assistance from neighbors or merchants who permanently reside near the parking area.

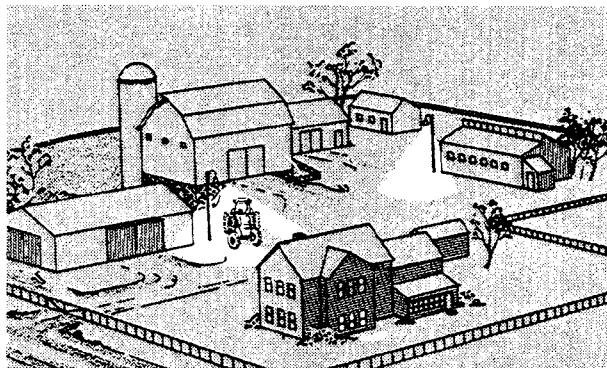

AB6/TS155 053/CRPRV E 091283

REDUCE VANDALISM

1. Install vandal protection devices especially if parking machine in high-risk areas.
2. Solicit assistance for watching machine from individuals residing in the area.
3. Take written notes and report to law enforcement all suspicious vehicles or persons.
4. Participate in a "Neighborhood Watch Program."

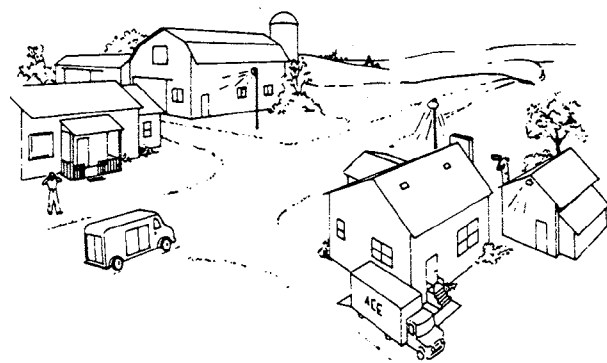

AB6/TS145 053/CRPRV F 100184

REPORT THEFT

1. If a theft occurs, notify the law enforcement agency having jurisdiction and the insurance carrier immediately.
2. Give a full description and a complete identification number(s) to the investigating officer and insurance carrier.
3. If available, provide the investigating officer with photographs of the actual machine, manufacturer's literature and knowledge of any identifiable marks that would assist in identifying the machine.
4. Ask for verification that the stolen machine has been entered into the National Crime Information Center (NCIC) operated by the FBI in Washington D.C.
5. Notify your John Deere dealer of the theft and request that, if possible, a notice be posted that provides the description and identification information.
6. Regularly check the identification plates on all machines and report any removed plates to law enforcement immediately. Promptly contact your dealer and order a duplicate identification plate.



AB6/TS146 053/CRPRV G 181183

053/P02 A 181183

<https://www.ebooklibonline.com>

Hello dear friend!

Thank you very much for reading.

Enter the link into your browser.

The full manual is available for immediate download.

<https://www.ebooklibonline.com>