



2140 Tractor



JOHN DEERE

OPERATORS MANUAL

2140
Tractor

OML34755 G0 English

**John Deere Werke Mannheim
John Deere Ibérica S.A. Getafe
OML34755 G0**

LITHO IN U.S.A.
ENGLISH





To the Purchaser

We appreciate the confidence you have shown in John Deere and your John Deere dealer for the purchase of this equipment.

We want you to have the best performance from your new machine. To accomplish this, your dealer will perform a Predelivery Inspection and will familiarize you with the proper and safe operation of this machine.

After the machine has operated the first 50 to 100 hours, you should contact your dealer and arrange an appropriate date at which the After-Sale Inspection will be performed. This inspection should not be done later than 100 operating hours after the machine has been delivered to you. It will be performed most effectively in the workshop of your dealer.

Following this page you will find a Predelivery Inspection check list, while at the end of this manual you will find the After-Sale Inspection check list.

These lists will be completed by your dealer when the inspections are being performed. He will then forward the original and one copy of each inspection to the John Deere Sales Branch Service Department, retaining the second copy for his files. The dealer will confirm completion of these in-

spections on that portion of the check list which remains in this manual.

The After-Sale Inspection is an important prerequisite to assure best performance of your new machine. For this reason you should not miss to make proper arrangements with your dealer to get this service done at the proper time.



This safety alert symbol indicates important safety messages in this manual. When you see this symbol, be alert to the possibility of personal injury and carefully read the message that follows.

To assure safe operation of this machine, read the Safety Rules on the first pages of this manual.

IMPORTANT! Your operator's manual contains the international standardized SI metric measurement system.

Right-hand and left-hand sides of this machine are determined by facing in the direction of forward travel.

Record the serial numbers of your machine as shown on one of the last pages of this manual and provide this information to your dealer when ordering spare parts.

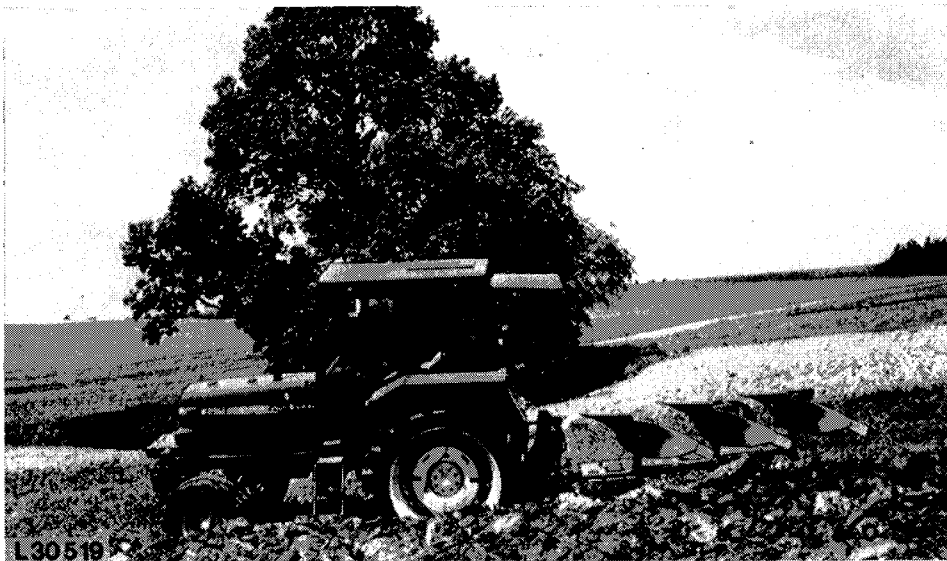

All information, illustrations, and specifications contained in this operator's manual are based on the latest information available at the time of publication. The right is reserved to make changes at any time without notice.



Contents

| | Page | | Page |
|--|------|----------------------------|------|
| Safety rules | 2 | Tractor storage | 102 |
| Controls and instruments | 5 | Trouble shooting | 103 |
| Operation | 8 | Specifications | 106 |
| Fuel and lubricants | 67 | Serial numbers | 111 |
| Lubrication and periodic service | 68 | Index | 112 |
| Service | 93 | | |



L16916 A



L16917

<https://www.ebooklibonline.com>

Hello dear friend!

Thank you very much for reading.

Enter the link into your browser.

The full manual is available for immediate download.

<https://www.ebooklibonline.com>



Safety Rules

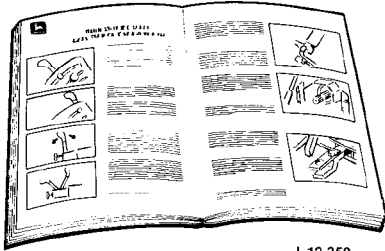

L 12 358

Do not put this **operator's manual** away unread. Read the manual carefully, regardless of your previous experience. Allow yourself this time, it will save you time and labour later on.

Always observe local **traffic regulations** when driving the tractor on public roads.

Become familiar with all **controls, indicators, warning lights, and warning plates** before operating the tractor.

Allow only trained operators to **use or adjust** the tractor.

Make sure that all **safety guards and shields** supplied with your tractor are serviceable and installed before operating tractor.

Never operate the tractor in a **closed building**. Danger of asphyxiation.

Always maintain **brakes** in excellent condition and adjustment. Brake pedals must be coupled together by means of the pedal coupler when driving on public roads.

Make sure that the tractor can be **safely steered and operated**, especially when driving up a steep hillside or down a slope.

Do not operate the tractor without a **roll guard**.

A protective four-post roll-guard is incorporated in each operator's cab. On this construction, as well as on tractor equipped with a roll-guard only, do not, under any circumstances, modify structural members of roll-guard by welding on additional parts, drilling holes etc. Disregarding this instruction can affect the rigidity of the roll-guard and therefore the operator's safety cannot be guaranteed.

The operator should be sure to have sufficient **visibility**.

To make sure that the tractor can be safely steered with rear-mounted implements, install **front weights**.

Drive slowly over rough ground or on hillsides and reduce speed when turning.

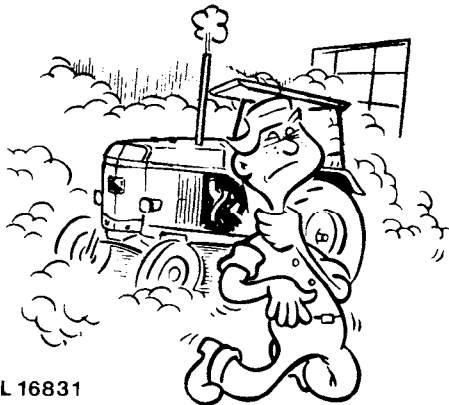

L 16831



L 16838

Always keep tractor in gear when driving down steep hills or inclines.

When driving out of a ditch, gully, or up a steep slope, engage the clutch slowly. Be prepared to declutch promptly if the front wheels rise off the ground. Use the same care if rear wheels mire in soft ground or drop into a hole. Back the tractor out of these spots if at all possible.

The power demands of attached or drawn implements should be well within the tractor's power range.

Trailers attached to the tractor should be equipped with a safely operating brake and lighting system.

Install additional red tail lights on rear-mounted implements covering the tractor tail lights or if the implement protrudes laterally.

Do not leave equipment raised when tractor is stopped. Always lower it to the ground.

Before starting engine make sure rockshaft control lever is in "equipment lowered" position.

After having disengaged the PTO, driven equipment does not become stationary immediately. Do not attempt to make adjustments or repairs while tractor is running unless specifically recommended. Disengage PTO, place transmission in park or apply handbrake, and shut off tractor engine before working on equipment.

Do not wear loose clothing near moving parts.

If a PTO-driven implement is attached, make sure powershaft shields are installed.

Chock rear wheel when parking on a slope.

Add coolant only with engine stopped or idling. Turn radiator cap slowly to relieve pressure before removing.

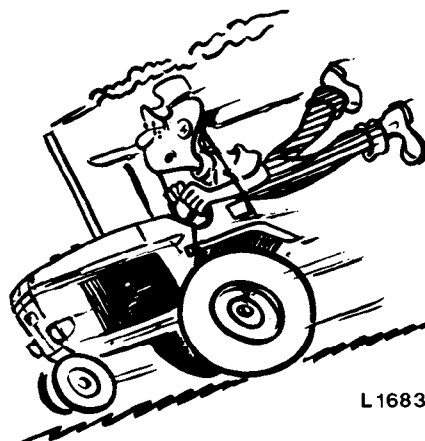

L 16833



L 16832

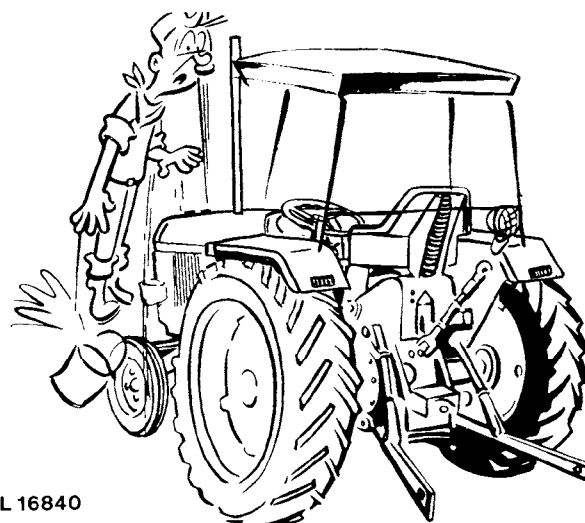

L 16840

4 Safety Rules

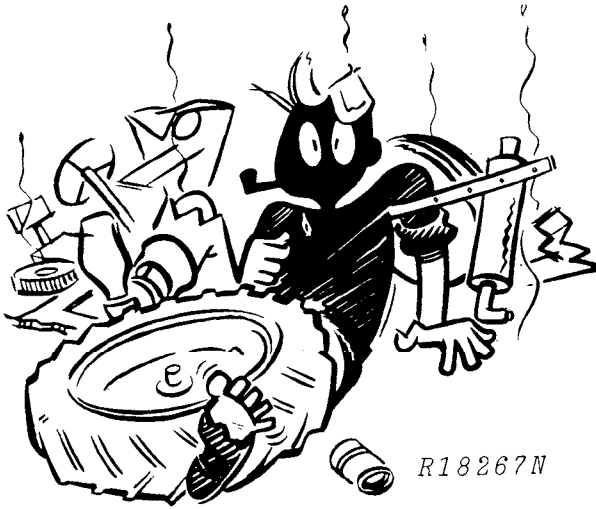

Use caution in handling any type of tractor fuel. Never refuel the tractor when the engine is hot or running. Do not smoke while filling the fuel tank or servicing the fuel system.

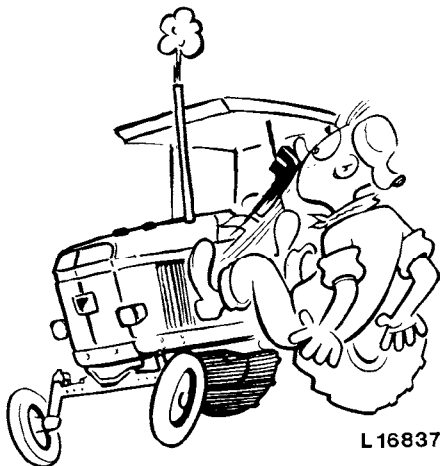

Do not refuel, grease or adjust the tractor while engine is running.

Always disconnect battery ground straps before adjusting engine or electrical system.

Escaping hydraulic oil under pressure can cause personal injury. Therefore, be sure all connections are tight and that lines and hoses are not damaged. Before disconnecting lines in the tractor hydraulic system, be sure to relieve all hydraulic pressure.

Do not allow passengers on the moving tractor unless a second seat is provided.

Provide a first-aid kit for use in case of accident.

It is a good practice to mount a fire extinguisher on the tractor. Be sure that the extinguisher is easily accessible and be familiar with its proper use.

Failure to follow proper procedures when mounting a tire on a wheel or rim can produce an explosion which may result in serious bodily injury. DO NOT attempt to mount a tire unless you have the proper equipment and experience to perform the job safely. Have it done by your John Deere dealer or a qualified tire repair service.

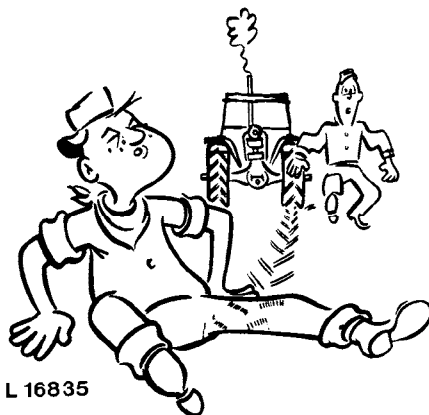

Detailed tire mounting instructions, including necessary safety precautions, are contained in John Deere Fundamentals of Service (FOS) Manual 55, Tires and Tracks, which is available from your John Deere dealer.



Controls and Instruments (Tractors without Cab)

"Bilux" Lighting System

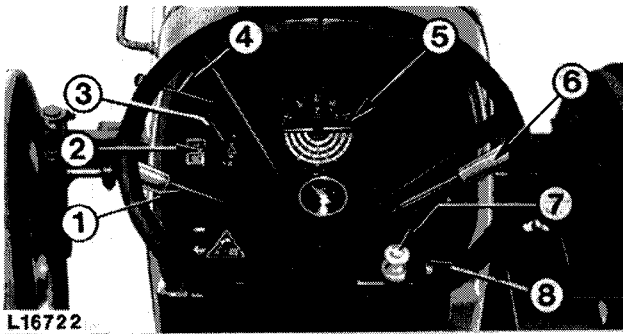

- 1 Hi-Lo or creeper transmission shift lever (optional eqpt.)
- 2 Full beam headlight switch
- 3 Hazard warning light switch

"Sealed-Beam" Lighting System

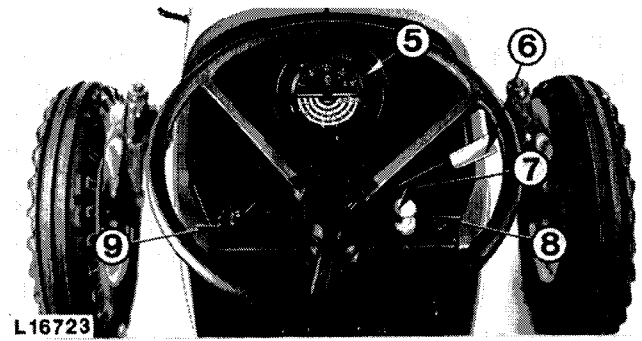

- 4 Turn signal and horn switch
- 5 Instrument cluster
- 6 Hand throttle

- 7 Engine shut-off knob
- 8 Starter switch
- 9 Light switch

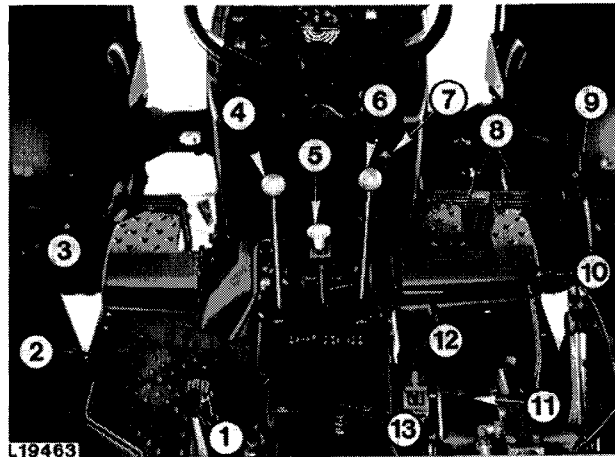

- 1 Differential lock (lever and pedal)
- 2 Handbrake lever
- 3 Clutch pedal
- 4 Range shift lever

- 5 PTO control lever
- 6 Gear shift lever
- 7 Main switch
- 8 Brake pedals

- 9 Rockshaft control lever
- 10 Selective control valve lever
- 11 Rockshaft selector lever
- 12 Foot throttle
- 13 Rate-of-drop lever



Controls and Instruments

(Tractors with Cab)

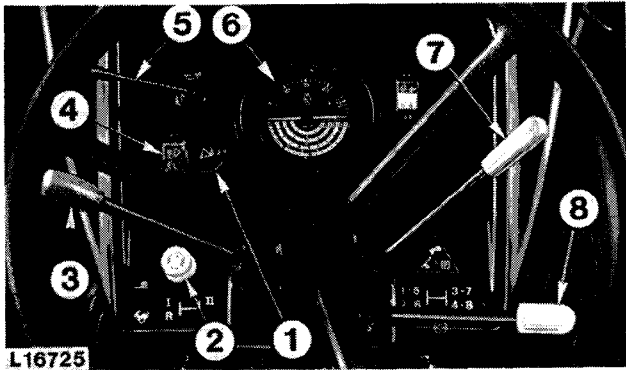

L16725

- 1 Hazard warning light switch
- 2 Engine shut-off knob
- 3 Hi-Lo or creeper transmission shift lever (optional eqpt.)
- 4 Full beam headlight switch

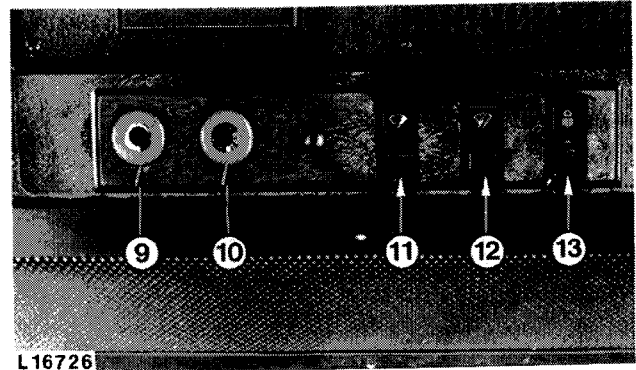

L16726

- 5 Turn signal and horn switch
- 6 Instrument cluster
- 7 Hand throttle
- 8 PTO control lever

- 9 Infinitely variable heater switch
- 10 Three-speed fan switch
- 11 Windshield wiper switch
- 12 Windshield washer switch
- 13 Worklight switch

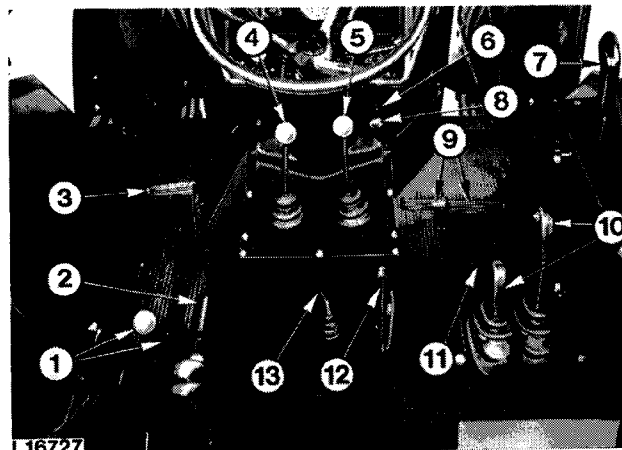

L16727

- 1 Differential lock (lever and pedal)
- 2 Handbrake lever
- 3 Clutch pedal
- 4 Range shift lever

- 5 Gear shift lever
- 6 Starter switch
- 7 Rockshaft control lever
- 8 Main switch
- 9 Brake pedals

- 10 Selective control valve lever
- 11 Foot throttle
- 12 Rockshaft selector lever
- 13 Rate-of-drop lever

Instrument Cluster

Air cleaner, alternator, engine oil pressure and transmission oil pressure* indicator lights should light up as soon as the main switch key is turned on. If this is not the case, a burnt-out bulb or blown fuse may be the cause. Replace defective bulb or blown fuse.

The control lights should go out as soon as the engine is running.

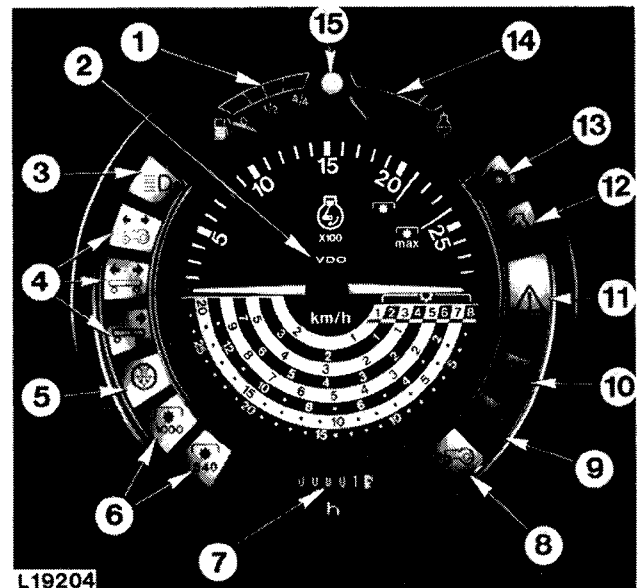

- 1 The fuel gauge shows amount of fuel in tank, from "full" (4/4) to "empty" (0). Never run fuel tank completely dry, otherwise you will have to bleed the fuel system.
- 2 The engine and tractor speed gauge shows the engine speed and tractor speed in the gear engaged.
- 3 The full-beam indicator light will go on as soon as the full-beam headlight switch is turned on.
- 4 The flashing indicator lights for tractor and trailer start flashing when turn-signal or hazard warning lights are turned on.
- 5 If air cleaner indicator light goes on with engine running, the air cleaner element must be cleaned or replaced.
- 6 The PTO speed indicator lights (on machines with PTO hand speed-change only) show the PTO speed engaged.
- 7 The hour meter shows the number of engine operation hours in full and tenths of hours. The hour meter facilitates close observation of the proper service intervals.
- 8 The front wheel drive indicator light glows when front wheel drive is engaged.
- 9 If alternator indicator light goes on with engine running, check for loose alternator connections, condition and tension of V-belt or defective alternator. If necessary have alternator checked by your John Deere dealer.
- 10 If transmission oil pressure indicator light goes on during tractor operation, stop tractor and check transmission/hydraulic oil level. Should indicator light glow and oil level is correct, then oil filter is clogged. Replace filter.
- 11 The warning light blinks when indicator light 9, 10 or 12 glows or when range shift lever is moved with handbrake applied.
- 12 If engine oil pressure indicator goes on with engine running, shut-off engine and check oil level.
- 13 The handbrake indicator light glows when handbrake is applied and main switch is turned on. Furthermore, an acoustical warning signal can be installed.
- 14 Should the coolant gauge needle move into the red zone the engine is overheating. Immediately reduce load or shift to a lower gear. Should the needle remain in the red zone, shut-off engine and determine cause of overheating.
- 15 This indicator light glows when fog tail light is switched on.



Operation

IMPORTANT! If the engine is to be run for a short time without battery (using a slave battery for starting), do not, under any circumstances, interrupt the circuit by switching off the main switch before stopping the engine by means of the fuel injection pump shut-off cable. Do not raise engine speed above 1000 rpm. Furthermore, use additional current (lights) while engine is running. Insulate battery end of disconnected starter cable properly to avoid damage to both alternator and regulator.

The following items must be checked daily before commencing work:

Oil level in engine crankcase

If oil level has sunk to bottom mark on dipstick, add sufficient oil to bring oil level up to top mark on dipstick.

A – Dipstick

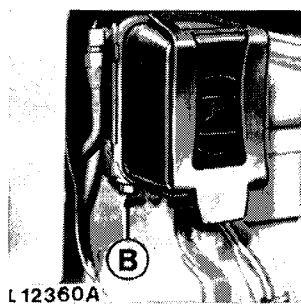
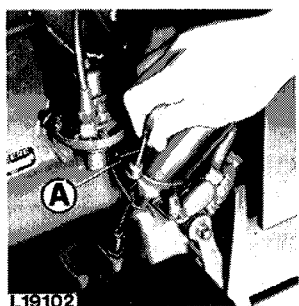

Fuel filter

Drain all water and sediment deposits from filter.

B – Drain plug

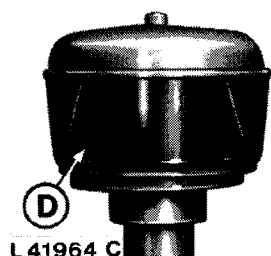
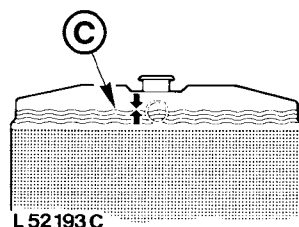

Radiator coolant level

Coolant should be maintained at a level midway between radiator core and filler neck.

C – Coolant level

Pre-cleaner (when equipped)

Clean collector bowl if dust has risen to mark.

D – Pre-cleaner

STARTING THE ENGINE
(Tractor with "Bilux" lighting system)

⚠ CAUTION! Before starting the engine, make sure there is plenty of ventilation. Never operate the engine in a closed building.

- 1 – Rockshaft control lever in "equipment lowered" position and selective control valve lever in "neutral".
- 2 – Push engine shut-off knob all the way in.
- 3 – Place range shift lever in neutral position.
- 4 – Slide hand throttle approximately one-third of its travel to the rear.
- 5 – Depress clutch pedal.
- 6 – Turn main switch key to position "1".
- 7 – If starting in warm weather or with warm engine, turn starter switch clockwise to end (operating starting motor) position. As soon as engine starts, turn starter switch to its original (OFF) position.

When starting in cold weather, turn starter switch anti-clockwise to first (Thermostart) position for 10 to 15 seconds. Then turn starter switch further to end (operating starting motor) position.

As soon as engine starts, turn starter switch back to thermostart position and hold starter switch in this position until engine runs smoothly and then turn to "OFF" position.

If engine does not start within 20 seconds, turn starter switch to "OFF" position and turn main switch key to position "0". Wait at least one minute before trying again.

- 8 – Run engine for one to two minutes, with temperature below zero for two to four minutes, with hand throttle applied as described under point 4.

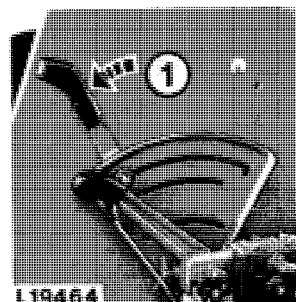

Without cab

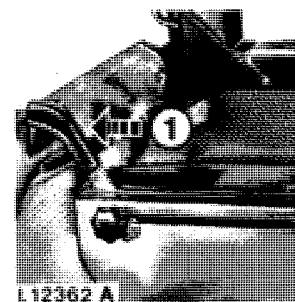

With cab

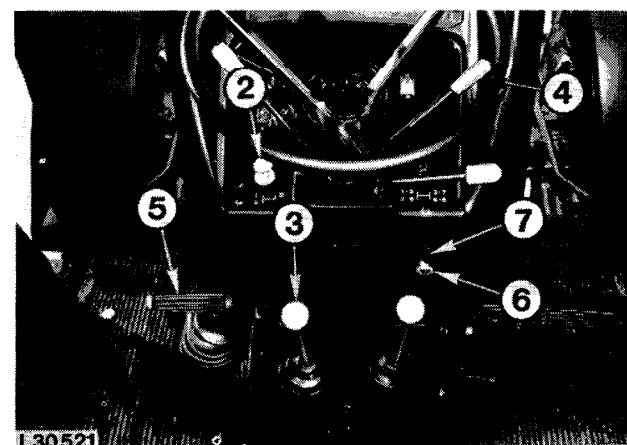
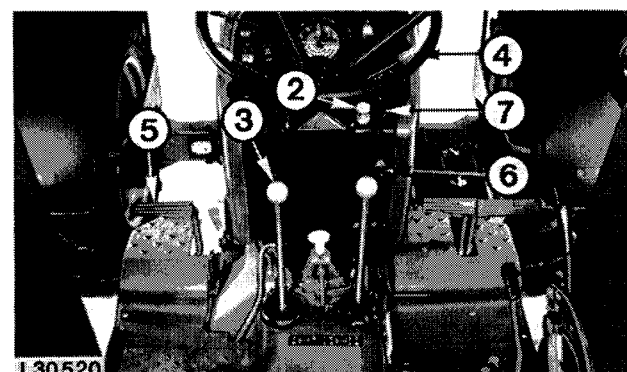

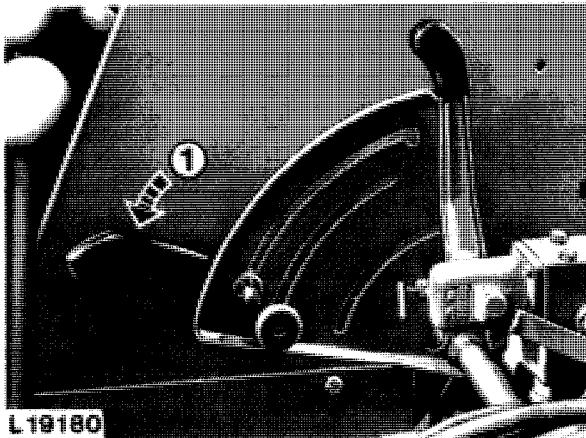

STARTING THE ENGINE
(Tractor with "Sealed-Beam" lighting system)

⚠ CAUTION! Before starting the engine, make sure there is plenty of ventilation. Never operate the engine in a closed building.

- 1 – Rockshaft control lever in "equipment lowered" position and selective control valve lever in "neutral".
- 2 – Push engine shut-off knob all the way in.
- 3 – Place range shift lever in neutral position.
- 4 – Slide hand throttle approximately one-third of its travel to the rear.
- 5 – Depress clutch pedal.

On tractors without starter switch

- 6 – Turn main switch key clockwise to end (operating starting motor) position. Keep switch engaged until engine starts. As soon as engine starts release main switch key.

On tractors with starter switch

- 7 – Turn main switch key to position "1".
- 8 – If starting in warm weather or with warm engine, turn starter switch clockwise to end (operating starting motor) position. As soon as engine starts, turn starter switch to its original (OFF) position.

When starting in cold weather, turn starter switch anti-clockwise to first (Thermostart) position for 10 to 15 seconds. Then turn starter switch further to end (operating starting motor) position.

As soon as engine starts, turn starter switch back to thermostart position and hold starter switch in this position until engine runs smoothly and then turn to "OFF" position.

If engine does not start within 20 seconds, turn starter switch to "OFF" position and turn main switch key to position "0". Wait at least one minute before trying again.

- 9 – Run engine for one to two minutes, with temperature below zero for two to four minutes, with hand throttle applied as described under point 4.

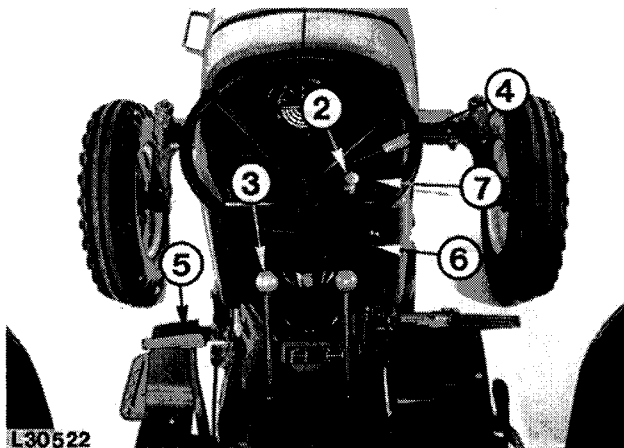

COLD WEATHER STARTING AIDS

Starting in cold weather with cold engine using diesel starting fluid.

When starting the engine at temperature below 0°C (+32°F), starting fluid can be injected into the intake manifold. Starting fluid spray cans are available from your John Deere dealer.



CAUTION! Starting fluid is highly flammable.

- A — Remove safety cap and
- B — Spray button
- C — Remove cap from adapter

IMPORTANT! To avoid damage, turn engine with starter one or two revolutions before injecting starting fluid.

Inject starting fluid only while engine is turning. Inject starting fluid intermittently, not continuously.

Position can onto adapter and inject fluid by pushing up on can for a short period.

Relax pressure on the can between "shots" of fluid. Stop injecting fluid as soon as the engine starts.

Run engine at low speed (throttle lever approx. 1/3 of travel to the rear)

If engine begins to die during the first few minutes of operation, inject another "shot" of fluid. When the engine is running smoothly, remove the can from the adapter and replace the safety cap on the can. Be sure to put the cap back on the adapter when not in use. This prevents dust from being drawn into the engine.

Store starting fluid cans where they will not be subject to extreme cold or heat. For best results, store fluid at room temperature.



CAUTION! Before discarding used starting fluid containers, empty them completely in a well ventilated area, at a good distance from sparks or open fire.

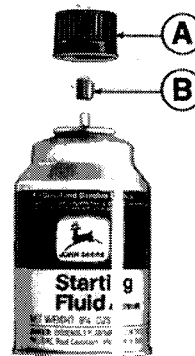

L12366 B

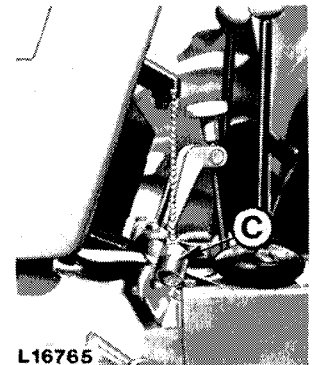

L16765



L16766

12 Operation

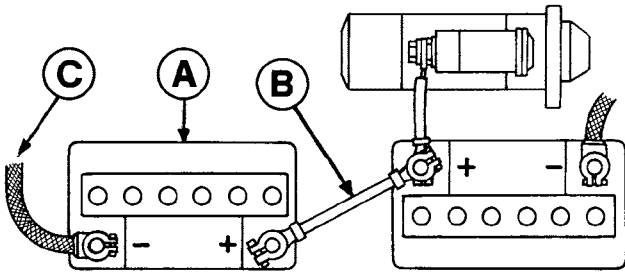

L 64703 B

- A — Auxiliary battery
- B — Connect both positive battery terminals
- C — Connect negative terminal to ground

Starting in cold weather with an auxiliary battery

Starting the engine in cold weather can be made easier by connecting an additional 12-volt battery in parallel with the 12-volt batteries on the tractor.

Use jumper cables to connect the positive (+) terminal of the booster battery to the positive (+) terminal of a tractor battery and the negative (-) terminal of the booster battery to negative (-) terminal of the tractor battery. See your JOHN DEERE dealer for booster batteries.

IMPORTANT! The batteries on your tractor are **NEGATIVE** grounded only. Reversed polarity in battery or alternator connections will result in damage to electrical system.

TOWING THE TRACTOR TO START

Should the tractor be started by towing or pushing, then use 6th, 7th or 8th gear only. Tow or push the tractor at a speed equivalent to the gear engaged.

ENGINE WARM-UP PERIOD

The engine must have attained the correct operating temperature before putting the unit under full load. To warm up the engine, run it for a few minutes with the hand throttle halfway open. Thus excessive wear on piston rings, cylinders and bearings is avoided.

STALLING THE ENGINE

Should you stall the engine, restart it immediately to prevent the oil from "frying" in the turbocharger.

STOPPING THE ENGINE

Stop tractor and engage parking lock or apply handbrake firmly.

Push hand throttle lever forward to stop and run engine for one to two minutes in slow idle.

- A – Pull shut-off knob.
Push the knob back in after the engine has stopped. Turn main switch to "Off" position.

Before leaving the tractor lower any equipment to the ground and make sure all switches are in "Off" position.

IMPORTANT! Never attempt to stop the engine by closing the shut-off tap at the fuel tank as this will cause the fuel injection pump to run dry and damage internal parts.

 **CAUTION!** Remove switch key to prevent accidents and battery discharge.

IMPORTANT! When engine is not running make sure exhaust stack flap is closed. This will prevent water and dirt from entering the engine.

TOWING THE TRACTOR

When towing the tractor, move both the gear and range shift levers to the neutral position.

 **CAUTION!** Never tow the tractor at a speed greater than 25 km/h (15 mph).



Without cab

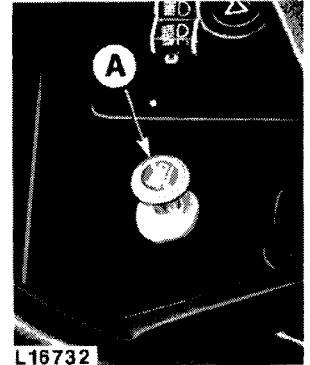

With cab

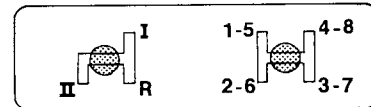

L12370

14 Operation

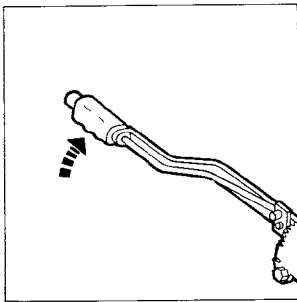

With handbrake

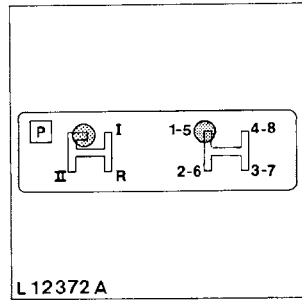

L12372 A

With parking lock

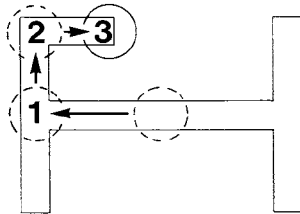

L 14659

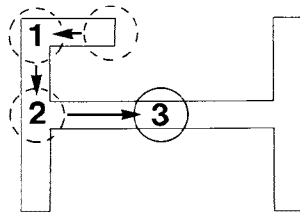

L 14657

PARKING THE TRACTOR

If the tractor has a handbrake, it should be well applied when the tractor is parked or when operating stationary.

If the tractor is provided with a parking lock, first engage 1st gear and then move range shift lever in park (P) position as follows:

1. Move range shift lever to the left
2. Move range shift lever forward
3. Move range shift lever to the right

To disengage parking lock:

When disengaging the parking lock, apply foot brakes and move range shift lever out of park (P) position as follows:

1. Move range shift lever to the left
2. Move range shift lever to the rear
3. Move range shift lever to the right

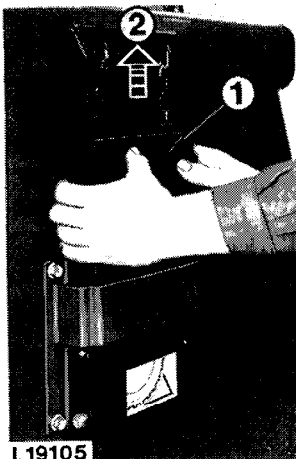

L19105

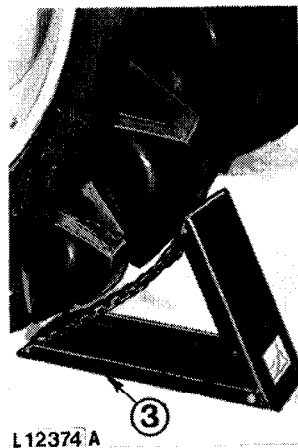

L12374 A

CHOCK BLOCK

For maximum safety, place chock in front or behind driving wheel when parking on slopes. Make sure tires are not underinflated to prevent chock from being "rolled-over". To avoid chock being forced into the ground, always use chock block on a firm surface.

- 1 – Press chock block together and
- 2 – Pull upward and remove
- 3 – Chock block ready for use

BREAK-IN PERIOD

During the first 100 hours of operation refer to the following chart:

| ITEM | SERVICE | LUBRICANT/SPECIFICATION |
|---|---|--|
| <p>After first 4 and 8 hours:</p> <p>Wheel retaining bolts*</p> | <p>Retighten</p> | <p>Rear wheels Wheel disk to axle flange: 400 Nm (300 ft-lb) Rim to wheel disk with steel disks: 250 Nm (185 ft-lb) Rim to wheel disk with cast disks and rack and pinion axle: 230 Nm (170 ft-lb)</p> <p>Front wheels (without MFWD) 180 Nm (130 ft-lb)</p> <p>Front wheels (with MFWD) Wheel disk to axle flange: 300 Nm (220 ft-lb) Rim to wheel disk with adjustable rims: 200 Nm (145 ft-lb)</p> <p>Front axle adjusting bolts 400 Nm (300 ft-lb)</p> |
| <p>After first 50 hours:</p> <p>Transmission oil filter</p> <p>Front axle oil (MFWD)</p> | <p>Renew</p> <p>Drain and refill</p> | <p>.....</p> <p>EP transmission oil (SAE 90) according to specification MIL-L 2105 B</p> |
| <p>After first 100 hours</p> <p>Front axle tie rod outer clamping bolts (see illustration on page 31)</p> <p>Front axle tie rod inner clamping bolts (see page 34)</p> <p>Engine crankcase oil</p> <p>Engine crankcase oil filter</p> | <p>Retighten</p> <p>Retighten</p> <p>Drain and refill</p> <p>Renew</p> | <p>110 Nm (80 ft-lb)</p> <p>40 Nm (30 ft-lb)</p> <p>John Deere Torq-GARD Supreme Oil or equivalent</p> <p>.....</p> |
| <p>During the first 100 hours:</p> | <ol style="list-style-type: none"> 1. Operate at normal loads. 2. Avoid light loads. 3. Avoid excessive engine idling. 4. Check engine crankcase oil level periodically. *5. Check wheel retaining bolts frequently. | |

NOTE: During the break-in period a higher-than-usual oil consumption should be considered as normal.



Suggest:

If the above button click is invalid.

Please download this document

first, and then click the above link

to download the complete manual.

Thank you so much for reading

16 Operation

SELECTING TRAVEL SPEEDS

The tractor has eight forward gears and four reverse gears. On tractors with Hi-Lo transmission sixteen forward gears and eight reverse gears and on tractors with creeper transmission, twelve forward gears and eight reverse gears.

Gears should be selected so as to avoid a permanent overloading of the engine.

Ground travel speeds with engine running at a speed different to the rated speed (2500 rpm) can be worked out as follows:

$$\frac{\text{Desired engine speed}}{2500 \text{ rpm}} = \text{Conversion factor}$$

The conversion factor multiplied by the speed shown in the table below gives the ground travel speed at the desired engine speed.

Example:

Ground travel speed at rated speed (2500 rpm) according to table below 9.3 km/h; Desired engine speed : 1300 rpm

$$\frac{1300 \text{ rpm}}{2500 \text{ rpm}} = 0.52$$

$$9.3 \text{ km/h} \times 0.52 = 4.8 \text{ km/h}$$

Should you wish to determine engine speed at a desired ground travel speed, proceed as follows:

$$\frac{\text{Desired ground travel speed}}{\text{Ground travel speed in table below}} = \text{Conversion factor}$$

The conversion factor multiplied by the rated speed (2500 rpm) gives you the desired engine rpm.

Example:

Ground travel speed at rated speed (2500 rpm) according to table below: 9.3 km/h; Desired ground travel speed: 5 km/h

$$\frac{5 \text{ km/h}}{9.3 \text{ km/h}} = 0.54$$

$$2500 \text{ rpm} \times 0.54 = 1350 \text{ rpm}$$

Travel Speeds for Tractors with Collar-Shift Transmission at 2500 Engine rpm

| Tire Size | | Up to 25 km/h (15.5 mph) | | | | | | Over 25 km/h (15.5 mph) | | | | | |
|-----------|-------|-------------------------------|------|---------|------|--------------------|------|-------------------------------|------|---------|------|--------------------|------|
| | | 13.6-38 15.5-38 16.9-34 | | 18.4-30 | | 14.9-38 23.1-26 | | 13.6-38 15.5-38 16.9-34 | | 18.4-30 | | 14.9-38 23.1-26 | |
| Gear | | km/h | mph | km/h | mph | km/h | mph | km/h | mph | km/h | mph | km/h | mph |
| 1 | Low | 1.9 | 1.2 | 1.9 | 1.1 | 2.0 | 1.2 | 2.2 | 1.4 | 2.2 | 1.3 | 2.3 | 1.4 |
| | High* | 2.4 | 1.5 | 2.4 | 1.5 | 2.5 | 1.5 | 2.8 | 1.8 | 2.8 | 1.7 | 2.9 | 1.8 |
| 2 | Low | 2.7 | 1.7 | 2.6 | 1.6 | 2.8 | 1.7 | 3.2 | 2.0 | 3.1 | 1.9 | 3.3 | 2.0 |
| | High* | 3.5 | 2.2 | 3.4 | 2.1 | 3.6 | 2.2 | 4.1 | 2.5 | 3.9 | 2.4 | 4.1 | 2.6 |
| 3 | Low | 4.0 | 2.5 | 3.9 | 2.4 | 4.1 | 2.6 | 4.7 | 2.9 | 4.6 | 2.8 | 4.8 | 3.0 |
| | High* | 5.1 | 3.2 | 5.0 | 3.1 | 5.3 | 3.3 | 6.0 | 3.7 | 5.8 | 3.6 | 6.2 | 3.8 |
| 4 | Low | 5.7 | 3.5 | 5.5 | 3.4 | 5.8 | 3.6 | 6.6 | 4.1 | 6.4 | 4.0 | 6.8 | 4.2 |
| | High* | 7.2 | 4.5 | 7.0 | 4.2 | 7.4 | 4.6 | 8.4 | 5.2 | 8.2 | 5.1 | 8.6 | 5.3 |
| 5 | Low | 6.7 | 4.2 | 6.5 | 4.1 | 6.9 | 4.3 | 7.9 | 4.9 | 7.6 | 4.7 | 8.0 | 5.0 |
| | High* | 8.6 | 5.3 | 8.3 | 5.2 | 8.8 | 5.4 | 10.0 | 6.2 | 9.7 | 6.0 | 10.2 | 6.4 |
| 6 | Low | 9.6 | 6.0 | 9.3 | 5.8 | 9.8 | 6.1 | 11.2 | 7.0 | 10.9 | 6.8 | 11.5 | 7.1 |
| | High* | 12.2 | 7.6 | 11.9 | 7.4 | 12.5 | 7.8 | 14.3 | 8.9 | 13.9 | 8.6 | 14.6 | 9.1 |
| 7 | Low | 14.3 | 8.9 | 13.8 | 8.6 | 14.6 | 9.1 | 16.7 | 10.4 | 16.2 | 10.0 | 17.1 | 10.6 |
| | High* | 18.1 | 11.3 | 17.6 | 10.9 | 18.6 | 11.5 | 21.2 | 13.2 | 20.6 | 12.8 | 21.7 | 13.5 |
| 8 | Low | 19.9 | 12.4 | 19.3 | 12.0 | 20.4 | 12.7 | 23.3 | 14.5 | 22.6 | 14.0 | 23.8 | 14.8 |
| | High* | 25.4 | 15.8 | 24.6 | 15.3 | 26.0 | 16.1 | 29.6 | 18.4 | 28.7 | 17.9 | 30.3 | 18.6 |
| R 1 | Low | 2.2 | 1.4 | 2.2 | 1.3 | 2.3 | 1.4 | 2.6 | 1.6 | 2.5 | 1.6 | 2.7 | 1.6 |
| | High* | 2.8 | 1.8 | 2.7 | 1.7 | 2.9 | 1.8 | 3.3 | 2.0 | 3.2 | 2.0 | 3.4 | 2.1 |
| R 2 | Low | 3.2 | 2.0 | 3.1 | 1.9 | 3.2 | 2.0 | 3.7 | 2.3 | 3.6 | 2.2 | 3.8 | 2.4 |
| | High* | 4.0 | 2.5 | 3.9 | 2.4 | 4.1 | 2.6 | 4.7 | 2.9 | 4.6 | 2.8 | 4.8 | 3.0 |
| R 3 | Low | 4.7 | 2.9 | 4.6 | 2.8 | 4.8 | 3.0 | 5.5 | 3.4 | 5.3 | 3.3 | 5.6 | 3.5 |
| | High* | 6.0 | 3.7 | 5.8 | 3.6 | 6.1 | 3.8 | 7.0 | 4.3 | 6.8 | 4.2 | 7.2 | 4.4 |
| R 4 | Low | 6.6 | 4.1 | 6.4 | 4.0 | 6.7 | 4.2 | 7.7 | 4.8 | 7.4 | 4.6 | 7.9 | 4.9 |
| | High* | 8.4 | 5.2 | 8.1 | 5.0 | 8.6 | 5.3 | 9.8 | 6.1 | 9.5 | 5.9 | 10.0 | 6.2 |

* Speeds shown under "High" also apply to tractors not equipped with Hi-Lo shift unit

<https://www.ebooklibonline.com>

Hello dear friend!

Thank you very much for reading.

Enter the link into your browser.

The full manual is available for immediate download.

<https://www.ebooklibonline.com>