

2040 TRACTOR (266715-)



JOHN DEERE

OPERATORS MANUAL

2040 TRACTOR
(266715-)

OML33529 I7 English

OML33529 I7

LITHO IN THE U.S.A.
ENGLISH





Contents

	Page
CONTROLS AND INSTRUMENTS	2
OPERATION	4
SAFETY RULES	31
FUELS AND LUBRICANTS	33
LUBRICATION AND PERIODIC SERVICE	35
SERVICE	48
TRACTOR STORAGE	59
TROUBLE SHOOTING	60
SPECIFICATIONS	63
INDEX	66

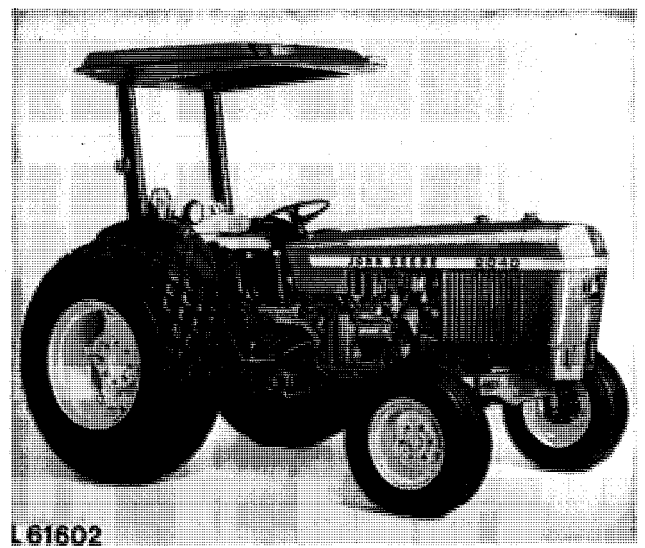
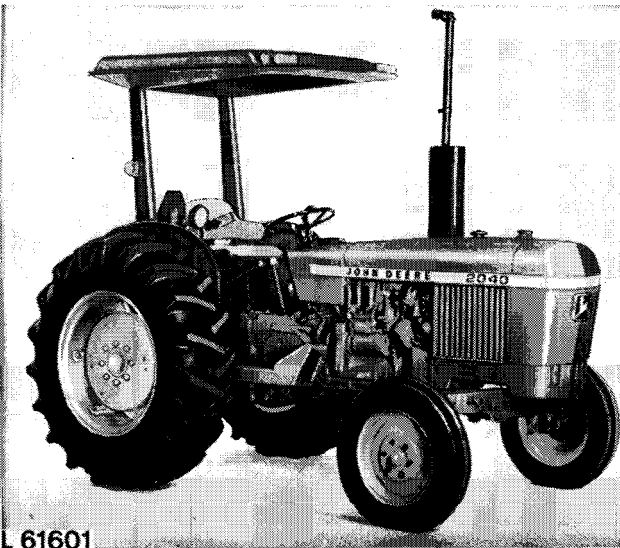

<https://www.ebooklibonline.com>

Hello dear friend!

Thank you very much for reading.

Enter the link into your browser.

The full manual is available for immediate download.

<https://www.ebooklibonline.com>

Instruments

Control Lights

Alternator



I 56768

The above control lights should light up as soon as switch key is moved clockwise to first position. If this is not the case, a burnt-out bulb may be the cause. If necessary, replace defective bulb.

The control lights should go out as soon as the engine is running and the engine speed has been raised. If this is not the case or if a light goes on during operation, immediately shut off engine and correct the problem.

If alternator indicator light goes on during engine operation, the alternator is not charging. Check for loose alternator connections, slackness of V-belt, or defective alternator.

If engine oil pressure indicator light goes on during engine operation, stop the engine, check oil level and condition of engine oil filter.

Engine Oil Pressure



I 56765

Air Cleaner Indicator Light



I 56765

If air cleaner indicator light goes on, clean air filter element or replace element after it has been cleaned six times.

Coolant Temperature Gauge

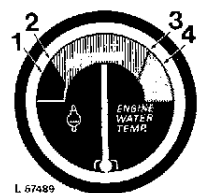

L 57489

- 1 – 38° C (100° F)
 - 2 – 57° C (135° F)
 - 3 – 107° C (224° F)
 - 4 – 116° C (240° F)
- Orange Warning Zone

If the gauge needle is in the orange warning zone, the engine is overheating and must be stopped at once. Check coolant level in radiator and check cooling system for leaks.

Fuel Gauge

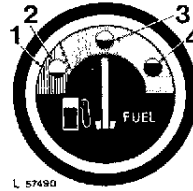

L 57480

- 1 – Orange Warning Zone
- 2 – Empty Tank
- 3 – Half-Full Tank
- 4 – Full Tank

The fuel gauge shows the amount of fuel in tank, from "empty" to "half-full" and "full".

Refill tank as soon as needle points to orange zone.

Never run fuel tank completely dry.

Speed-Hour Meter

The speed-hour meter facilitates the economical use of the tractor under all operating conditions. It also facilitates choosing the right gear.

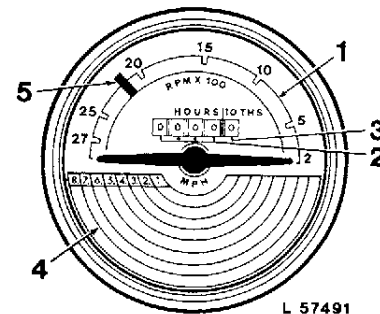

L 57491

The speed-hour meter shows the following:

- 1 Engine speed on the upper half of the dial. The figure shown multiplied by 100 indicates the actual number of engine revolutions.
 - 2 Hours of operation in full hours.
 - 3 Hours of operation in tenths of hours.
- The hour meter facilitates close observation of the proper service intervals.
- 4 The tractor speed for the gear engaged.
 - 5 PTO operation. The green mark shows the engine speed required for powershaft operation.



Operation

PRE-STARTING INSPECTION

IMPORTANT: If the tractor is to be operated without battery (using a slave battery for starting), do not, under any circumstances, interrupt the circuit by switching off the starter switch before stopping engine by means of fuel pump stop cable. Having stopped the engine, switch off starter switch and remove key. It is also recommended to use additional current (lights) while engine is running.

Connect slave battery in the proper polarity (negative to ground).

Further details about the alternator are given on page 54.

The following items must be checked daily before commencing work:

Oil Level in Engine Crankcase

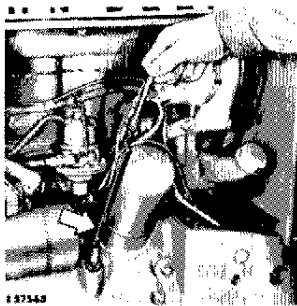

If oil level has dropped to bottom mark on dipstick, add sufficient oil to bring oil level up to top mark on dipstick.

See page 34 for correct oil.

Radiator Coolant Level

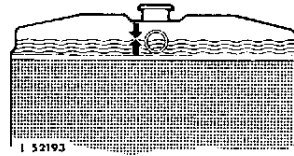

Coolant should be maintained at a level midway between radiator core and filler neck.

See "Cooling System" section for correct coolant mixture.

Fuel Filter



Drain all water and dirt deposits from fuel filter.

The drain plug is located at the bottom of the filter body.

Fuel Shut-Off Valve

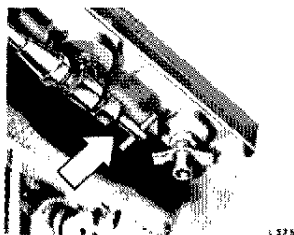

Make sure fuel shut-off valve located under fuel tank is open.

STARTING THE ENGINE

CAUTION: Before starting engine make sure rock-shaft control lever is in forward (equipment lowered) position.

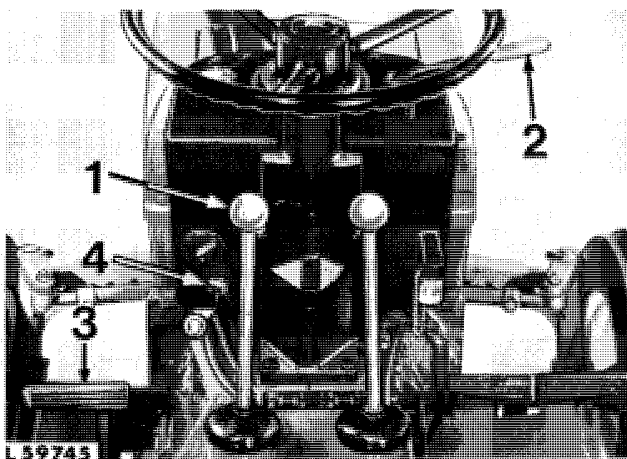

- 1 Place range shift lever in neutral or park position.
- 2 Place hand throttle in halfway-open position.
- 3 Depress clutch pedal to decrease drag on engine.
- 4 Turn starter key clockwise to engage starter. As soon as engine starts, release starter key. Do not crank engine for more than 30 seconds at a time. To do so may overheat the starter. Wait a minute or two before engaging starter again.

Release clutch pedal. In cold weather, warm engine and transmission for 5 minutes by operating engine at half throttle.

NOTE: If engine fails to start, refer to "Trouble Shooting" charts.

CAUTION: If you must tow the tractor for starting, do not tow it at a speed greater than normal for the gear in which the tractor is being towed. Tow the tractor for starting only in 6th, 7th, or 8th. gear. Never tow the tractor at a speed greater than 25 km/h (15 mph).

COLD WEATHER STARTING AIDS

To assist in cold weather starting, several aids are available. These aids are effective at low temperatures only when the engine is otherwise operating satisfactorily. They will not correct such deficiencies as low battery charge, crankcase oil of too heavy viscosity, or high electrical resistance, any of which may prevent the engine from starting.

Auxiliary Batteries

Starting the engine in cold weather can be made easier by connecting an additional 12-volt battery in parallel with the 12-volt battery (or batteries) on the tractor.

CAUTION: Gas given off by batteries is explosive. To avoid injury or battery damage, avoid sparks near the batteries.

Use jumper cables to connect the positive (+) terminal of the booster battery to the positive (+) terminal of the tractor batteries and the negative (-) terminal of the booster battery to a good ground on the tractor frame away from the battery. See your JOHN DEERE dealer for booster batteries.

IMPORTANT: The batteries on your tractor are **NEGATIVE** grounded only. Reversed polarity in battery or alternator connections will result in damage to electrical system.

Diesel Starting Fluid Adapter

Your tractor is equipped with a starting fluid adapter. This attachment is used to inject atomized starting fluid into the engine air intake system when starting the engine at temperatures below 0° C (+ 32° F).



To use starting fluid, remove the safety cap and plastic spray button from the can.

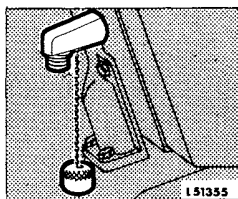

Remove cap from adapter.

Injecting Diesel Starting Fluid

IMPORTANT: To avoid damage, turn engine with starter one or two revolutions before injecting starting fluid.

Inject starting fluid only while engine is turning. Inject starting fluid intermittently, not continuously.

6 Operation

Injecting Diesel Starting Fluid – Continued



Position can onto adapter and inject fluid by pushing up on can for a short period.

Relax pressure on the can between "shots" of fluid. Stop injecting fluid as soon as the engine starts. If engine begins to die during the first few minutes of operation, inject another "shot" of fluid. When the engine is running smoothly, remove the can from the adapter and replace the safety cap on the can. Be sure to put the cap back on the adapter when not in use. This prevents dust from being drawn into the engine.

Store starting fluid in a cool, dry, and protected area to prevent accidental discharge. Keep the starting fluid away from extreme heat or cold.

CAUTION: Ether starting fluid is highly flammable. Do not use near fire, sparks, or flames. Read the cautionary information on the container.

Engine Coolant Heater

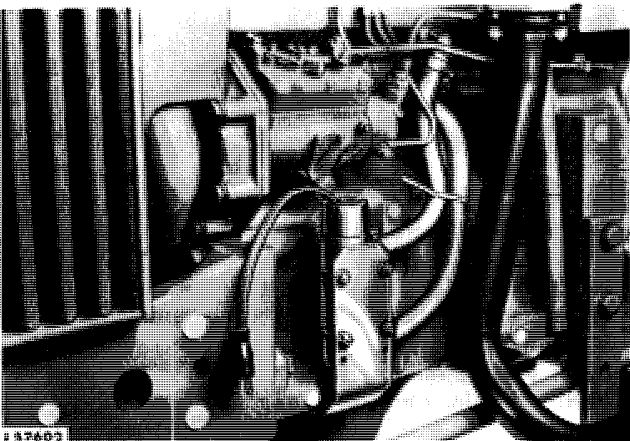

A 1000-watt, 115-volt electrical coolant heater can be installed on the engine. The heater can be plugged into any 115-volt electrical source.

CAUTION: To avoid shock or hazardous operation, always use a three wire heavy-duty electrical cord equipped with 3 wire connectors. If a 2 to 3 contact adapter is used at the wall receptacle, always connect the green wire to a good ground.



CAUTION: Before starting the engine, make sure there is plenty of ventilation. Never operate the engine in a closed shed or garage.

ENGINE WARM-UP PERIOD

The engine must have attained the correct operating temperature before putting the unit under full load. To warm up the engine, run it for a few minutes with the hand throttle halfway open. Thus excessive wear on piston rings, cylinders and bearings is avoided.

ENGINE IDLING

Avoid unnecessary engine idling. Prolonged engine idling may cause the engine coolant temperature to drop below its normal range. This in turn causes crankcase oil dilution, due to incomplete fuel combustion, and permits formation of lacquer or gummy deposits on valves, pistons, and piston rings. It also promotes rapid accumulation of engine sludge.

ENGINE SPEEDS

The engine working speed range is between 1500 and 2500 rpm. Within these limits the engine can be put under full load. Maximum continuous power is obtained at 2500 rpm.

Operate the engine at 2100 rpm to obtain SAE standard PTO speeds.

When using the PTO, set the hand throttle so that the engine speed pointer is even with the green mark on the speed-hour meter.

STOPPING THE ENGINE

Run the engine at 1400 rpm for a short time before shutting it off completely. This will allow the engine to cool off gradually.

To stop the engine, pull out the shut-off knob (located at bottom — left on dash). Push knob back in as soon as engine has stopped.

IMPORTANT: Never attempt to stop the engine by closing the shut-off valve at the fuel tank as this will cause the pump to run dry and damage internal parts.

 **CAUTION:** Remove starter key to prevent accidents, tampering, and unauthorized operation.

PARKING THE TRACTOR

Completely stop the tractor. Move the gear shift lever into 1-5 gear position. Then move the range shift lever to park (P) position.

Before dismounting, be sure all equipment is lowered to the ground and the light switch and other accessory switches are off.

TOWING THE TRACTOR

When towing the tractor, move both the gear and range shift levers to the neutral position. Thus you will avoid any unnecessary transmission wear.

 **CAUTION:** Never tow the tractor at a speed greater than 25 km/h (15 mph).

BREAK-IN PERIOD

After the first 4 hours and 8 hours of operation retighten all wheel retainers and front axle bolts. Check tightness of retainers and axle bolts frequently during the first 100 hours of operation.

Thereafter check tightness of bolts and screws periodically.

Recommended torques are as follows:

Rear Wheels

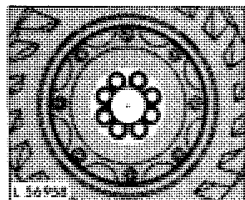

Wheel disk-to-axle flange
180 Nm (130 ft.lbs.)
torque.

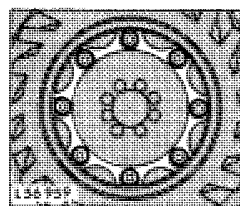

Rim-to-wheel disk 200
Nm (145 ft.lbs.) torque.

Front Wheels

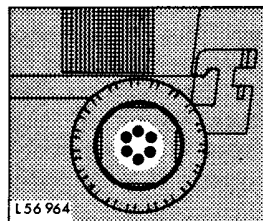

Wheel-to-axle flange 180
Nm (130 ft.lbs.) torque.

Front Axle

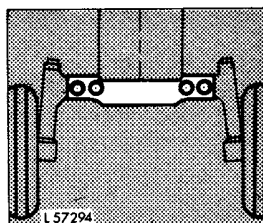

Axle bolts 400 Nm (300
ft. lbs.) torque.

The tractor should be operated under normal load during the first 20 hours of operation.

IMPORTANT: Avoid light loads or excessive engine idling.

Ideal conditions for breaking in a tractor engine would require operating the tractor at full engine speed under 75% of full load. Under such operating conditions an engine would be broken in after approximately the first 100 hours.

In most cases, however, it is practically impossible to operate the tractor under these conditions during the first hours. This is the reason why, in many cases, the duration of the break-in period is considerably longer than 100 hours.

Under very light load conditions some engines may never break in which results in glazed cylinder liners.

During the break-in period a higher-than-usual oil consumption should be considered as normal.

Check periodically to be sure that an adequate supply of oil is maintained in the crankcase.

At the end of the first 50 hours of operation, replace the transmission system oil filter.

8 Operation

BREAK-IN PERIOD – Continued

At the end of the first 100 hours of operation, drain and refill crankcase and replace filter element.

We recommend that you ask your JOHN DEERE dealer to carry out a general inspection of the tractor before the first 100 operating hours are completed.

SELECTING TRAVEL SPEEDS

The tractor has eight forward gears and four reverse gears. These gears, together with the engine speeds that may be selected, allow the operator to balance load and speed for maximum economy, and give him flexibility to meet varying work conditions. For example, for a given travel speed the operator may choose to work in a low gear at a high engine speed or in a higher gear at a lower engine speed.

Gears should be selected so as to avoid a permanent overloading of the engine.

HIGH SPEED DRIVING

A higher gear can be used when traveling on good, straight roads.

On bad, curvy roads or when working on slopes, it is necessary to shift to a lower gear and to reduce speed.



CAUTION: Fast driving causes many accidents. Couple the brake pedals together and always drive at a safe speed when driving on public roads.

TRAVEL SPEEDS AT 2500 ENGINE RPM

Tire Sizes	13.6 - 28		14.9 - 28		16.9 - 24		21.5L - 16.1		16.5L - 16.1		18.4 - 16.1	
	km/h	mph	km/h	mph	km/h	mph	km/h	mph	km/h	mph	km/h	mph
1	2.3	1.4	2.4	1.5	2.3	1.4	1.9	1.2	1.7	1.1	1.9	1.2
2	3.3	2.0	3.5	2.2	3.2	2.0	2.7	1.7	2.5	1.5	2.7	1.7
3	4.9	3.0	5.2	3.2	4.8	3.0	4.0	2.5	3.7	2.3	4.0	2.5
4	6.8	4.2	7.2	4.5	6.7	4.2	5.5	3.4	5.1	3.2	5.6	3.5
5	9.0	5.6	9.6	6.0	8.9	5.5	7.3	4.4	6.8	4.2	7.5	4.6
6	12.9	8.0	13.5	8.5	12.7	7.9	10.5	6.5	9.7	6.0	10.6	6.6
7	19.1	11.8	20.3	12.6	18.8	11.7	15.5	9.6	14.4	8.9	15.8	9.8
8	26.7	16.6	28.4	17.6	26.2	16.3	21.7	13.5	20.1	12.5	22.1	13.7
R 1	2.7	1.7	2.8	1.8	2.6	1.6	2.2	1.3	2.0	1.3	2.2	1.4
R 2	3.8	2.4	4.1	2.5	3.7	2.3	3.1	1.9	2.9	1.8	3.2	2.0
R 3	5.7	3.5	6.0	3.7	5.6	3.5	4.6	2.9	4.3	2.6	4.7	2.9
R 4	7.9	4.9	8.4	5.2	7.8	4.8	6.4	4.0	6.0	3.7	6.5	4.1

**TRAVEL SPEEDS AT 2100 ENGINE RPM
(Engine Speed For PTO Operation)**

Tire Sizes	13.6 - 28		14.9 - 28		16.9 - 24		21.5L - 16.1		16.5L - 16.1		18.4 - 16.1	
	km/h	mph	km/h	mph	km/h	mph	km/h	mph	km/h	mph	km/h	mph
1	1.9	1.2	2.0	1.2	1.9	1.1	1.6	1.0	1.5	0.9	1.6	1.0
2	2.7	1.8	2.9	1.8	2.7	1.7	2.3	1.4	2.1	1.3	2.3	1.4
3	4.1	2.5	4.4	2.7	4.0	2.5	3.3	2.1	3.1	1.9	3.4	2.1
4	5.7	3.6	6.1	3.8	5.6	3.5	4.6	2.9	4.3	2.7	4.7	3.0
5	7.5	4.7	8.1	5.0	7.4	4.6	6.1	3.9	5.7	3.5	6.2	3.9
6	10.8	6.7	11.4	7.1	10.6	6.6	8.7	5.4	8.1	5.1	8.9	5.5

SHIFTING GEARS

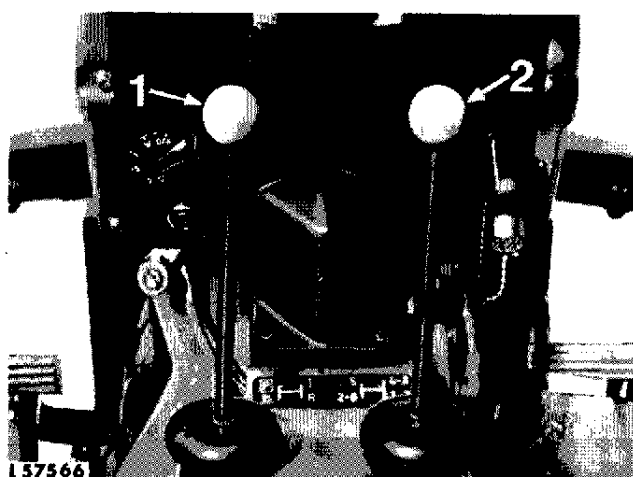

- 1 Range Shift Lever (Left-Hand Lever)
- 2 Gear Shift Lever (Right-Hand Lever)

Gear shifting is controlled by a range shift lever and a gear shift lever.

With the range shift lever a low or high range of gears can be engaged.

Shift Pattern

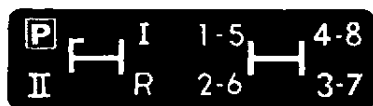

156 971

Range Shift Lever Positions

- I Low Range
- II High Range

Gear Shift Lever Positions

- P Park Position
- R Reverse Range

Use range shift lever to engage park (P) position.

The gear shift lever can be used to select 1st, 2nd, 3rd, and 4th gears when the range shift lever is in low range position; it can be used to select 5th, 6th, 7th, and 8th gears when the range shift lever is in high range position. When the range shift lever is in reverse range, reverse gears comparable to 1st, 2nd, 3rd, and 4th can be obtained.

Shifting from Neutral

1. Depress clutch pedal.
2. Move range and gear shift levers in the position required.
3. Gradually release clutch pedal, however, do not allow clutch to slip longer than necessary to take up load smoothly.

To shift "on the go" from lower to higher gear, increase engine speed, depress clutch, decrease engine speed, engage higher gear, release clutch slowly and increase engine speed.

To shift "on the go" from higher to lower gear, decrease engine speed, depress clutch pedal, place gear shift lever in neutral, release clutch momentarily, increase engine speed, declutch, and select lower gear. Release clutch slowly.

Avoid gear clash when shifting "on the go".

Shifting to Another Range

To shift to another range fully stop the unit, disengage the clutch and then change gear range as required.

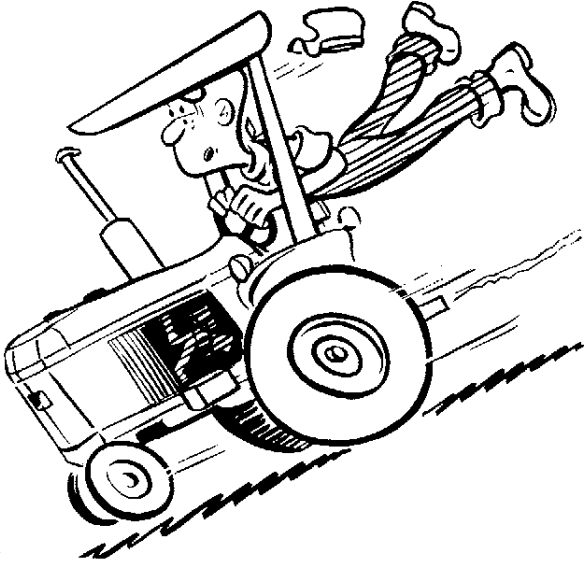

CAUTION: Do not allow tractor to coast downhill with clutch disengaged and transmission in gear. This could result in loss of control, in over-speeding, and damage to the clutch.

DIFFERENTIAL LOCK

With differential lock engaged, power is transferred equally to both rear wheels. This prevents the usual loss of traction when one wheel is slipping.

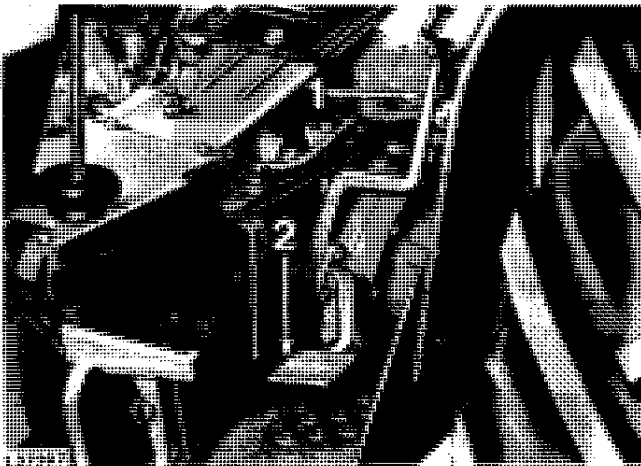

1 Hand Lever
2 Pedal

When slippery conditions are encountered with unequal wheel slip, engage differential lock (lever or pedal).

Depress clutch pedal to engage differential lock if wheel slip varies greatly between both wheels or if one wheel has become stationary. Engage differential lock as clutch is re-engaged. The differential lock will disengage automatically as soon as traction has equalized.

If unequal traction is not continuous, retain lever or pedal in engaged position.

CAUTION: Do not operate the tractor at high speeds or attempt to turn the tractor with the differential lock engaged.

STEERING

The tractor may be equipped with manual or power steering. Power steering makes steering and control of the tractor easier for the operator. In case of pressure failure, the tractor can be steered manually.

HYDRAULIC FOOT BRAKES

CAUTION: Brake pedals should be coupled together by means of pedal coupler when traveling at high speeds or when driving on public roads.

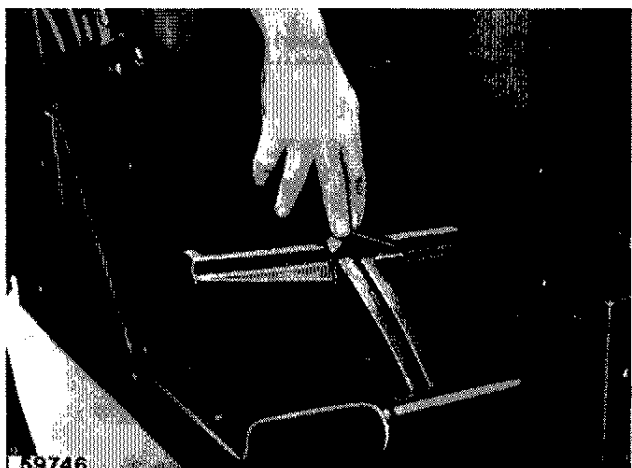

Coupling Brake Pedals Together

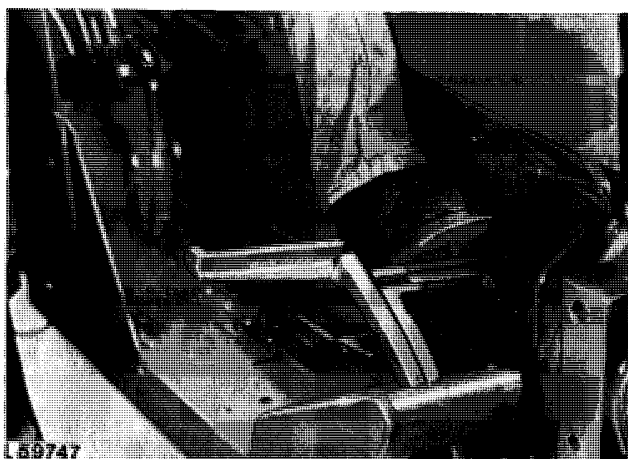

Using Foot Brake to Make a Sharp Left-Hand Turn

When turning the tractor, press down on a single brake pedal. Use the left pedal to turn left and the right pedal to turn right. When negotiating sharp turns, press brake pedal down more sharply as the steering wheel is being turned.

Use brake for steering purposes at low speed only.

When stopping the tractor, press down on both brake pedals.

CAUTION: Your safety depends on efficient brakes. Always maintain brakes in excellent condition and adjustment.

TOWED LOADS

CAUTION: Towed loads that weigh more than twice the weight of the tractor should have brakes. If not, reduce speed and avoid inclines.

LIGHTS

Light Switch

Switch positions are marked on the light switch plate. Turn switch clockwise until position required is in uppermost (vertical) position.

Light switch positions are as follows:

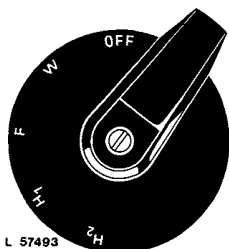

- Off
- W Warning Lamps
- F Bright Headlights and Rear Work Light
- H1 Bright Headlights, Tail Light and Warning Lamps
- H2 Dim Headlights, Tail Light and Warning Lamps

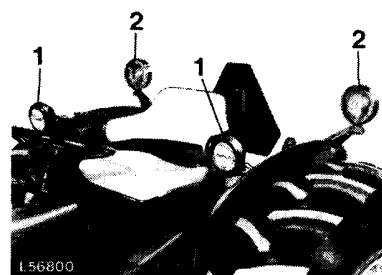

1 Headlights 2 Tractor Warning Lamps, Front View

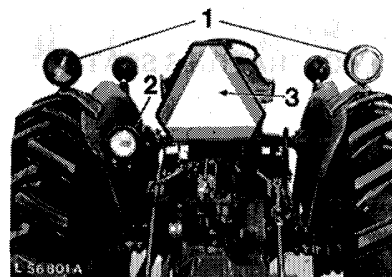

1 Tractor Warning Lamps, Rear View 2 Rear Work Light and Tail Light 3 Slow moving vehicle emblem

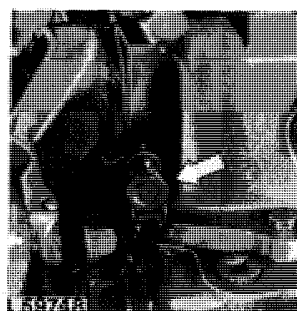

Provision has been made for the installation of an electrical outlet socket at rear of tractor. If required, see your John Deere dealer.

Turn-Signal Switch (If Equipped)

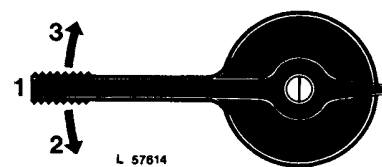

1 Off 2 Turn Signal Light, Left 3 Turn Signal Light, Right

HIGHWAY DRIVING

When transporting (or driving) the tractor on a road or highway at night or during the day, use accessory lights and devices for adequate warning to the operators of other vehicles. In this regard, check local governmental regulations. Various safety lights and devices are available from your John Deere dealer.

When driving on the highway, use light switch position H1 or H2. Be sure the lights are adjusted so they will not blind the driver of an oncoming vehicle.

Always dim (H2 position) the tractor headlights when meeting a vehicle at night.

CAUTION: Keep slow moving vehicle emblem in place and keep it clean.

12 Operation

Your tractor is equipped with a warning lamp flasher. If local traffic regulations prohibit its use, change into constant burning lamps as follows:

1. Disconnect the orange with white stripe lead from the "W" terminal of the light switch.
2. Disconnect the orange lead from the flasher and connect it to the "W" terminal.

A label (R56774) with the above instructions is attached to the left-hand warning lamp.

OPERATOR'S SEAT

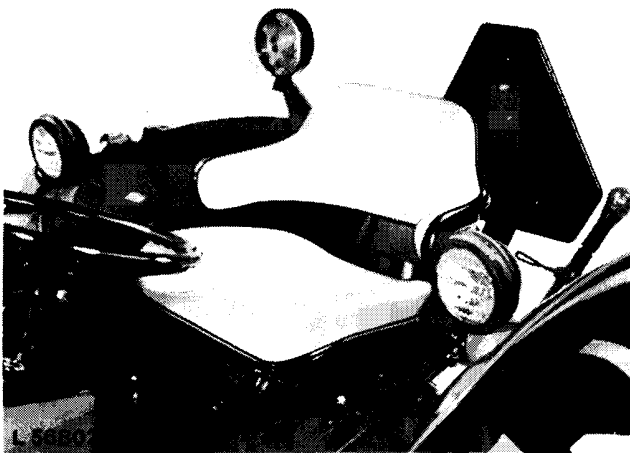

The deluxe seat is adjustable for the operator's height and weight and folds back for standing.

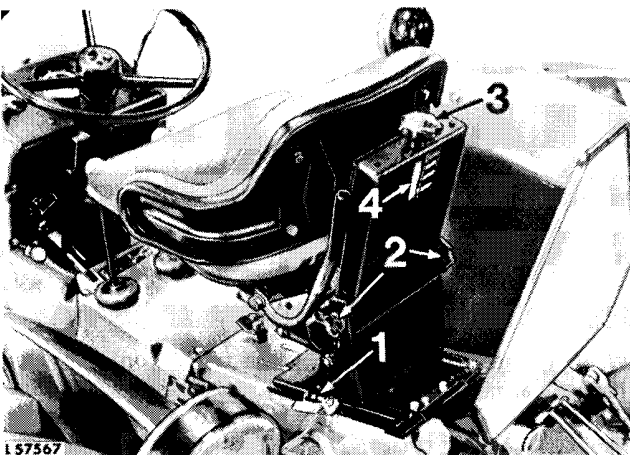

- 1 Raise catch and adjust horizontally.
- 2 Loosen handwheels on both sides and adjust seat to desired height. Retighten both handwheels securely.
- 3 Handwheel for adjusting according to operator's weight.
- 4 Weight adjustment pattern.

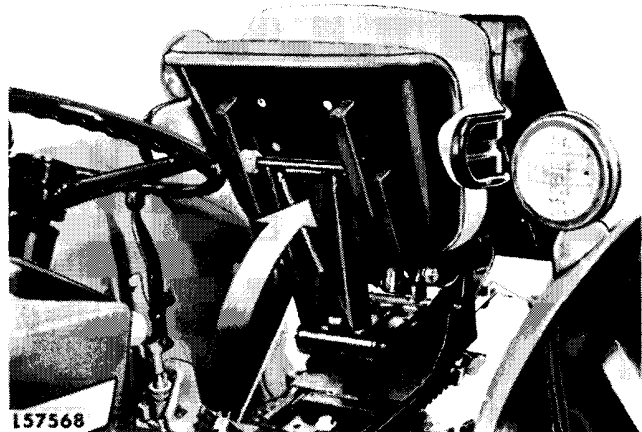

The operator's seat can be folded back against the backrest to drive tractor while standing.

ROLL-GARD AND SEAT BELT

A protective Roll-Gard with seat belt is available for your tractor. A canopy that fits on top of the Roll-Gard is also available.

When installing a Roll-Gard, tighten the cap screws sufficiently to hold the mounting plate flat against the axle housing. Then in a diagonal sequence, tighten to 70 Nm (50 ft. lbs.) torque. Retighten the cap screws in the same sequence to 400 Nm (300 ft. lbs.) torque. After a few hours of service, retighten the cap screws and keep them tight.

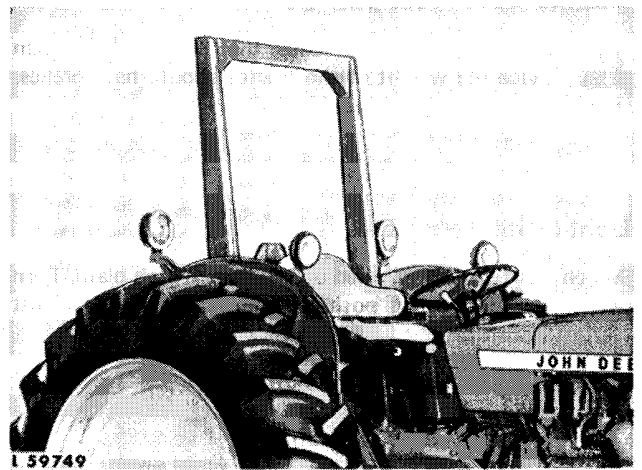

CAUTION: Under almost all operating conditions:

1. Use of the seat belt with the optional John Deere Roll-Gard is recommended.
2. Use of a seat belt without roll-over protective equipment is not recommended.

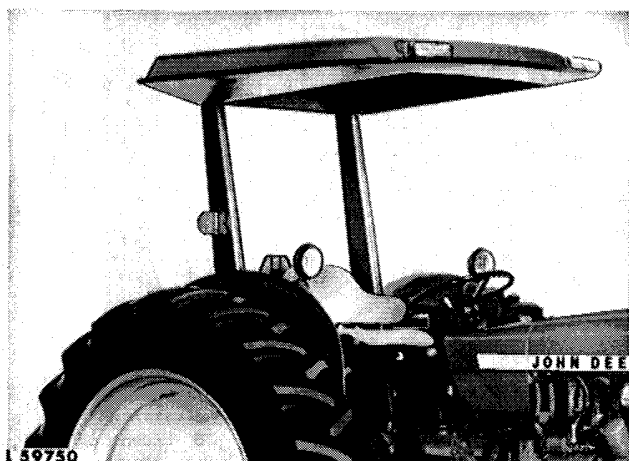

CAUTION: A tractor roll-over may place a severe stress on the Roll-Gard structure. Therefore, re-use of the Roll-Gard is not recommended if its upright beams, cross-bar, or attaching parts have been bent, buckled, or stretched.

CAUTION: Under no circumstances modify structural members of roll-gard by welding on additional parts, drilling holes etc. Disregarding this instruction can affect the rigidity of the Roll-Gard and therefore the operator's safety cannot be guaranteed.

CAUTION: If your tractor has a Roll-Gard, use Non-Spill battery vent caps to prevent injury from spilled battery acid should the tractor overturn and be supported upside-down by the Roll-Gard (see page 54).

WHEEL TREADS

Adjustable Front Axle

Two types of front axles are available. The type of front axle installed is dependent upon the size of the rear wheels. Wheel treads available are shown in the following chart:

Front Tire Size	Front Wheel Tread*		Max. with Wheels Reversed
	Min.	Max.	
6.00 - 16	1260 mm - 1880 mm (49.5 in. - 74.0 in.)		2020 mm (79.5 in.)
6.50 - 16			
7.50 - 16			
27/9.5-15**	1320 mm - 1945 mm (52.0 in. - 76.5 in.)		-
27/9.5-15***	1180 mm - 1610 mm (46.0 in. - 63.5 in.)		-
23/10.5-12	1120 mm - 1550 mm (44.0 in. - 61.0 in.)		1700 mm (67.0 in.)

* Front axle adjustable in increments of 50 mm (2.0 in.)

** Used with 16.9-24 rear tires (medium knee).

*** Used with 18.4-16.1 or 21.5L-16.1 rear tires (short knee).

IMPORTANT: To avoid excessive stress on axle bolts, do not separate axle halves beyond the limits shown.

Bolt spacing should be 102 mm (4 in.) in maximum tread width and 153 mm (6 in.) in all other tread widths.

Adjusting Front Wheel Tread

Jack up front end of tractor.

Do not place jack under engine oil pan.

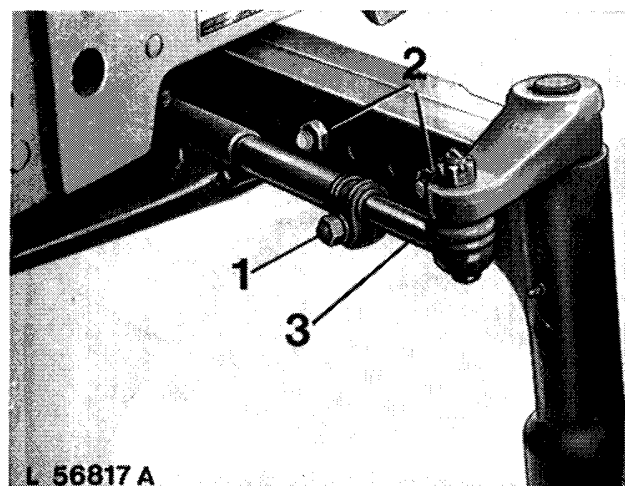

- 1 Remove tie rod clamp bolts.
- 2 Remove axle bolts and reposition axle ends to the desired front wheel tread. Insert axle bolts and tighten nuts to 400 Nm (300 ft. lbs.) torque.
- 3 The tie rods have grooves to simplify adjustment. Adjust the same distance as the axles. Insert and tighten tie rod clamp bolts to 120 Nm (85 ft. lbs.) torque.

Check to see that front wheels turn equally to right and left. Check toe-in and adjust, if necessary.

Checking Front Wheel Toe-In

Check front wheel toe-in periodically with tractor on level ground and front wheels in straight-ahead position.

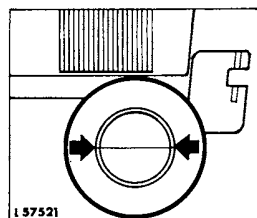

Front and rear of front wheels at hub height.

14 Operation

Checking Front Wheel Toe-In — Continued

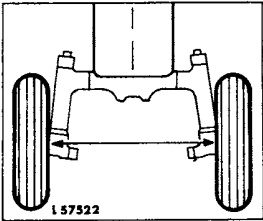

Measure from rim flange to rim flange.

Proper toe-in is 3 to 6 mm (0.13 to 0.25 in.) less in front than in rear.

Adjusting Front Wheel Toe-In

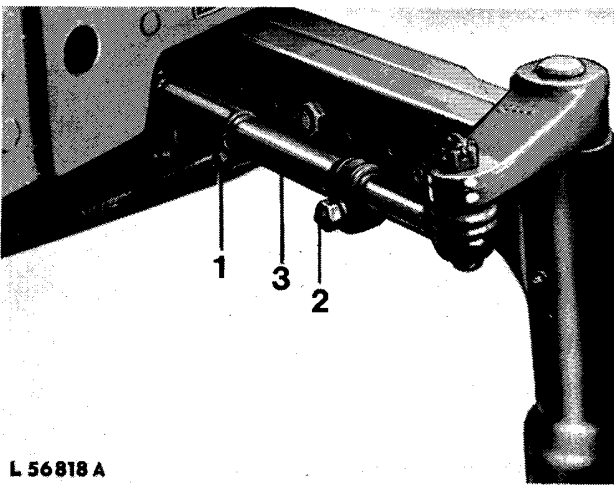

L 56818 A

- 1 Loosen Inner Clamping Bolt
- 2 Remove Outer Clamping Bolt
- 3 Turn Tie-Rod Tube In or Out

Turn tie-rod in to shorten and turn out to increase amount of toe-in.

Turn each tie-rod an equal amount so that front wheels remain in straight-ahead position.

After toe-in adjustment is completed, tighten inner clamping bolts to 40 Nm (30 ft.lbs.) torque. Insert and tighten outer clamping bolts to 120 Nm (85 ft. lbs.) torque.

Periodically check the tightness of the front wheel retainer cap screws. They should be tightened to 120 Nm (85 ft. lbs.) torque.

REAR WHEEL TREADS

Power Adjusted Rear Wheels

Power adjusted rear wheels make tread adjustment a quick, easy job. It is possible to change rear wheel treads by engine power without jacking up the tractor.

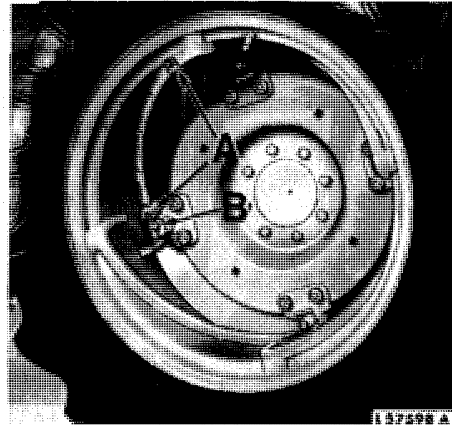

A Stop (2 used)

B Eccentric Pin

Wheel Tread

Tire Size	Minimum	Maximum
13.6 – 28	1260 mm (49.6 in.)	1870 mm (73.5 in.)
14.9 – 28	1360 mm (53.5 in.)	1870 mm (73.5 in.)

Adjust tread as follows:

1. Remove the two pins from rim stops which position each wheel disk to the rim and remove stops (A).
2. Replace one stop on wheel disk at the limiting tread position desired and secure with a pin.
3. Loosen the four eccentric pins(B).
4. Drive tractor forward or backward to rotate the disk in relation to the rails on rim, until the wheel disk contacts stop.
5. Secure remaining stop against wheel clamp, tightening securely.
6. Tighten eccentric pins.
7. Adjust tread on second wheel in the same way as described above.

NOTE: Retighten pins after 10 hours operation and keep them tight.

Demountable Rim Wheels

Rear wheel tread can be adjusted by re-positioning or reversing the rims or by reversing the wheel disks.

Rear wheel tread can also be adjusted by reversing the complete wheels. When reversing the wheels, they must be changed from one side to the other so that the arrow on side wall of tire points in the direction of forward rotation of tire.

After adjustment has been completed, tighten inner attaching screws (wheel to axle) to 180 Nm (130 ft. lbs.) torque.

The outer attaching screws (rim to disk) must be tightened to 200 Nm (145 ft. lbs.) torque.

NOTE: Retighten inner and outer attaching cap screws to specified torque after 10 hours operation and keep them tight.

The relationship of the rear wheel disk and rim in obtaining the different tread settings is shown in the following drawings. A study of these drawings before attempting to change tread settings will save time and unnecessary labor.

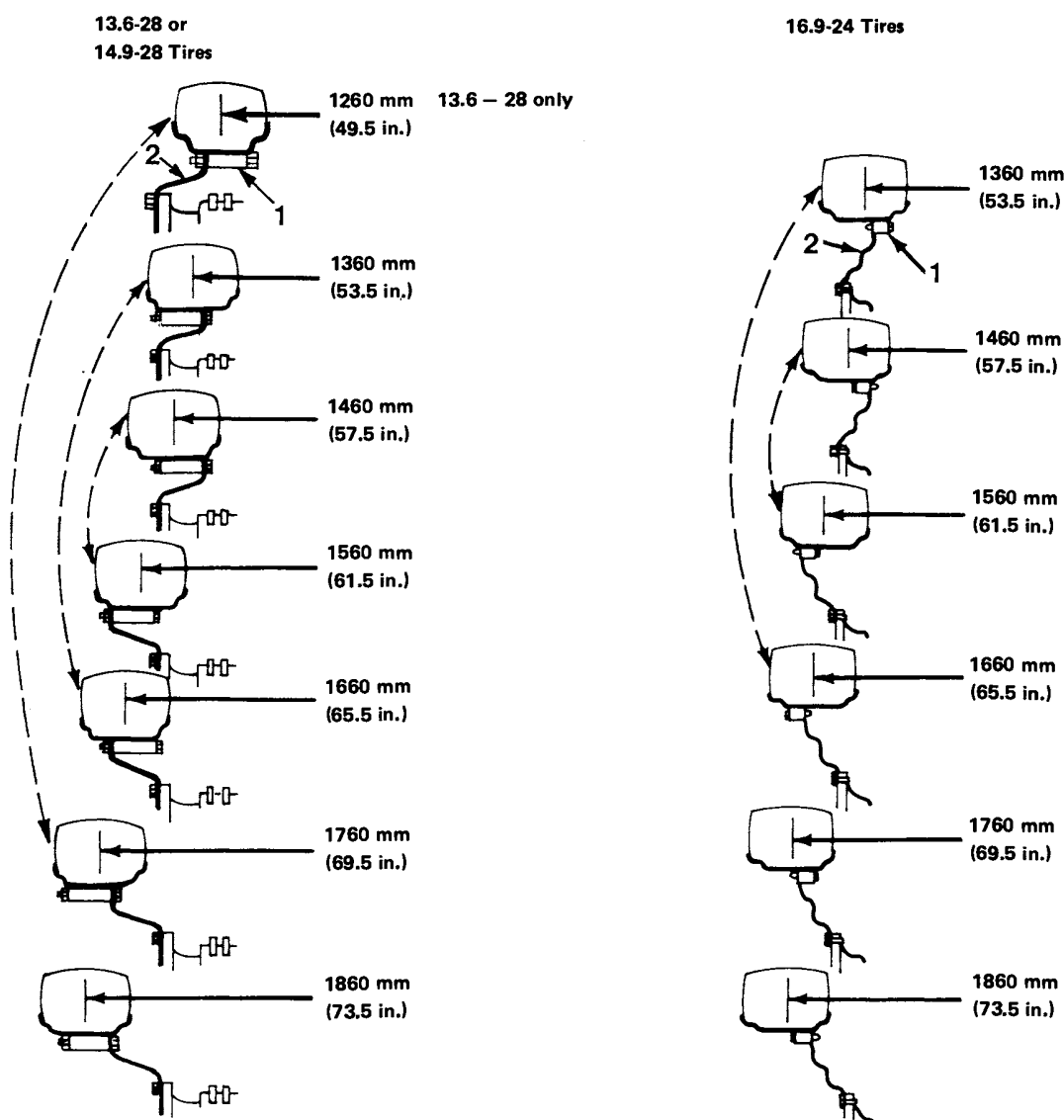

L 57603 A

1 Bracket 2 Wheel Disk

The dashed line in illustration above shows the tread width obtained by reversing the entire wheel and installing on opposite side of tractor. The arrow on the side wall of each tire must then point in the direction of forward travel. Therefore, wheels must be installed inversely on opposite side of tractor.

IMPORTANT: When mounting or changing tires, make sure arrow on side of tire points in direction of forward rotation.

Steel Disk Wheels

Tractors with 16.5L-16.1 rear tires on steel disk rear wheels have rear wheel treads of 1320 or 1700 mm (52 or 67 in.). With 21.5L-16.1 or 18.4-16.1 rear tires, the rear wheel treads are 1445 or 1575 mm (57 or 62 in.). Tighten the wheel disk-to-axle bolts evenly to 180 Nm (130 ft. lbs.) torque.

NOTE: Retighten bolts to specified torque after 10 hours operation and keep them tight.

DIRECTION OF TIRE ROTATION

When mounting or changing tires, make sure arrow on side-wall of tires points in the direction of forward rotation.

TIRE PRESSURE



UNDER INFLATION



OVER INFLATION



L 56 866 PROPER INFLATION

Properly inflated tires are important to the operation of your tractor. The amount of air pressure to be carried in the front and rear tires depends upon the implement used with the tractor and the amount of ballast employed.

Keep the tires inflated according to the recommendations shown in the charts. Under-inflated tires break and wear out rapidly. Over-inflated tires reduce traction, increase wheel slippage and wear.

INFLATION CHARTS

Front Tires			
Tire Size	Ply Rating	Inflation Pressure	
		With Towed or Rear-Mounted Implement	With Max. Ballast or Front-Mounted Implement
6,00-16	6	2.5 bar (36 psi)	3.5 bar (48 psi)
6,50-16	6	2.5 bar (36 psi)	3.5 bar (48 psi)
7,50-16	6	2 bar (28 psi)	2.5 bar (36 psi)
23/10,5-12	4	1.3 bar (18 psi)	Not Recommended
27/9,5-15	4	1.8 bar (25 psi)	1.8 bar (25 psi)

Rear Tires			
Tire Size	Ply Rating	Inflation Pressure	
		With Little or No Added Ballast	With Max. Ballast or Heavy Rear-Mounted Implement
13,6-28	4	1 bar (14 psi)	1 bar (14 psi)
14,9-28	6	1 bar (14 psi)	1.3 bar (18 psi)
16,5L-16,1	6	1.4 bar (20 psi)	Not Recommended
16,9-24	6	1.1 bar (16 psi)	1.1 bar (16 psi)
18,4-16,1	6	1 bar (14 psi)	1.1 bar (16 psi)
21,5L-16,1	6	0.8 bar (12 psi)	0.8 bar (12 psi)

BALLAST

The performance of your tractor will be improved if the correct amount of front or rear ballast is used to obtain the proper amount of rear wheel slippage. Front ballast will help maintain stability and steering control when front weight is transferred to the rear wheels.

Rear Ballast

The amount of rear ballast should permit operation with approximately 10 to 15 percent slip of the rear wheels. Field tests show that under normal field conditions maximum drawbar horsepower is available when operating in this range.

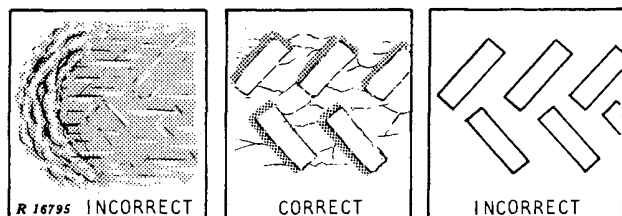

Tire Tread Patterns

If too much rear ballast is used, the tread marks will be clear and distinct. Overballasting results in less power available to pull the implement because more power is required to overcome tractor rolling resistance. It will result in unnecessary soil compaction, and may overload the tires. With too little rear wheel ballast, the tread marks will be obliterated by excessive slippage which also results in horsepower loss and excessive tire wear.



Suggest:

If the above button click is invalid.

Please download this document

first, and then click the above link

to download the complete manual.

Thank you so much for reading

A compromise in ballasting may be necessary when the tractor is used to pull loads having different draft requirements. If the tractor is used most of the time pulling high draft loads (such as plowing), ballast the tractor for this operation. However, if a large amount of time is spent on light load work or in the higher gears, more consideration should be given to ballasting for the light operating condition and permitting the slip to increase for the small amount of time spent on high draft work.

Measuring Slippage

The following method may be used to measure rear wheel slip.

1. Mark a reference line on the side of the tire. Walk along side of the tractor while it is working and drop a marker where the chalk mark comes down to the ground.
2. Continue along side, count off 10 wheel revolutions, and again mark the spot where the chalk mark comes down to the ground.
3. With the implement out of the ground, drive the tractor between the marked spots, again marking the tire beside the marker on the ground. Count the wheel revolutions between the markers on the ground, estimating the last revolution as close as possible.
4. Determine the percent of slip from the revolutions obtained in Step 3.

Revolutions	Percent of Slip	Revolutions	Percent of Slip
9-1/2	5	8	20
9	10	7-1/2	25
8-1/2	15	7	30

Add or remove ballast as required to obtain approximately 10 to 15 percent slip for the desired field operating condition.

Cast-Iron Weights

When additional weight is required, cast-iron weights may be bolted to the inside or outside of the rear wheels.



CAUTION: Be sure wheel bolts are always properly tightened.

For 24 in. steel wheels on flanged axle . . . 48 kg (106 lbs)
 For 28 in. power adjusted steel wheels
 on flanged axle 48 kg (106 lbs)

Liquid Weight

Water and calcium chloride solution is an economical means of adding weight to the wheels. The addition of calcium chloride is recommended to prevent the water from freezing.

Use of this method of weighting the wheels has the full approval of the tire companies. See your John Deere dealer for this service. The following chart lists the liquid weight each tire will hold when 75 percent full (filled to valve level).

**LIQUID WEIGHT PER TIRE
(75 PERCENT FILLED)**

Tire size	Slush free at -10° C (13° F); Solid at -30° C (-23° F) (Approx. 1 kg [2 lbs.] CaCl ₂ per 4 liters [1 gal.] of water).	Slush free at -24° C (-12° F); Solid at -47° C (-52° F) (Approx. 1.5 kg [3.5 lbs.] CaCl ₂ per 4 liters [1 gal.] of water).	Slush free at -47° C (-53° F); Solid at -52° C (-62° F) (Approx. 2.25 kg [5 lbs.] CaCl ₂ per 4 liters [1 gal.] of water).
13.6-28	184 kg (405 lbs)	200 kg (440 lbs)	212 kg (467 lbs)
14.9-28	229 kg (505 lbs)	247 kg (545 lbs)	260 kg (574 lbs)
16.5L-16.1	142 kg (312 lbs)	150 kg (330 lbs)	163 kg (360 lbs)
16.9-24	263 kg (580 lbs)	279 kg (615 lbs)	297 kg (654 lbs)
18.4-16.1	188 kg (415 lbs)	200 kg (440 lbs)	212 kg (467 lbs)
21.5L-16.1	261 kg (575 lbs)	288 kg (635 lbs)	306 kg (675 lbs)

Maximum Ballast

Rear axle ballast should never exceed the weight required to provide traction for loads within the 4th gear operating range of the tractor.

Do not add too much ballast. In continuous operation this could lead to damage to the tractor. Remove ballast if tractor engine labors or stalls when pulling heavy loads in gears 1, 2 and 3.

Front Ballast

Front ballast may be required for stability and steering control when weight on the front wheels is transferred to the rear wheels by implement action through the hitch.

Ballasting for Field Operation

The approximate total front tractor weight for normal field operation is as follows:

1. Approximately 1/3 of total tractor weight for operation of integral implements or semi-integral implements.
2. Approximately 1/4 of the total tractor weight for operation of towed implements hitched to the tractor drawbar.

<https://www.ebooklibonline.com>

Hello dear friend!

Thank you very much for reading.

Enter the link into your browser.

The full manual is available for immediate download.

<https://www.ebooklibonline.com>