

1640, 2040 and 2040 S Tractors (From Serial No. 450,000 L)



JOHN DEERE

OPERATORS MANUAL

1640, 2040 and 2040 S Tractors (From
Serial No. 450,000 L)

OML40926 E6 English

John Deere Werke Mannheim
OML40926 E6

LITHO IN U.S.A.
ENGLISH





INSPECTIONS

We appreciate the confidence you have shown in John Deere and your John Deere dealer for the purchase of this equipment.

We want you to have the best performance from your new machine. To accomplish this, your dealer will perform a Predelivery Inspection and will familiarize you with the proper and safe operation of this machine.

After the machine has operated the first 100 hours, you should contact your dealer and arrange an appropriate date at which the After-Sale Inspection will be performed. It will be performed most effectively in the workshop of your dealer.

Your dealer completed the predelivery inspection according to the check list, while at the end of this manual you will find the After-Sale Inspection check list.

These check lists will be completed by your dealer while the inspections are being performed. He will then forward the original and one copy of each inspection list to the John Deere Sales Branch Service Department, retaining the second copy for his files. The dealer will confirm completion of these inspections on that portion of the check list which remains in this manual.

The After-Sale Inspection is an important prerequisite to assure best performance of your new machine. For this reason you should not miss THE OPPORTUNITY to make proper arrangements with your dealer to get this service done at the proper time.

© Deere & Co., European Office,
D-6800 Mannheim

SAFETY



CAUTION: This safety alert symbol indicates important safety messages in this manual. When you see this symbol, be alert to the possibility of personal injury and carefully read the message that follows.

IMPORTANT: This machine is designed and manufactured according to JOHN DEERE specifications. To avoid accidents and to assure optimum performance the machine must not be modified or altered in ways not approved by JOHN DEERE, nor must it be used in conditions or for purposes it is not designed for.

To assure safe operation of this machine, read and observe the Safety Rules on the first pages of this manual.

MEASUREMENTS

Your operator's manual contains the international standardized SI metric measurement system.

DIRECTION

Right-hand and left-hand sides of this machine are determined by facing in the direction of forward travel.

SERIAL NUMBERS

Record the serial numbers of your machine in the spaces provided at the end of this manual and provide this information to your dealer when ordering spare parts.

All information, illustrations and specifications contained in this operators manual are based on the latest information available at the time of publication. The right is reserved to make changes at any time without notice.

Identification Views



L102773

L102773-1640ALE-010386



L32 209A

L32209A-1640ALE-010386

<https://www.ebooklibonline.com>

Hello dear friend!

Thank you very much for reading.

Enter the link into your browser.

The full manual is available for immediate download.

<https://www.ebooklibonline.com>

Contents

Safety	05-	Operators Platform and Cab	30-
– General	05-1	– “Bilux” lighting	30-1
– Operation	05-4	– “Sealed-Beam” lighting	30-5
– Service	05-6	– Operator’s seat	30-6
 		– Roll guard	30-7
Controls and Instruments	10-	– Seat belt	30-7
– Controls	10-1	– Opening windows	30-7
– Instruments	10-2	– Torques for hardware	30-8
– Control lights	10-3	– SG2 cab	30-8
 		– MC1 cab	30-12
Break-In Period	15-	 	
– After first 4 and 8 hours	15-1	Wheel Treads, Tires and Ballast	35-
– After first 50 hours	15-1	Wheel treads	35-1
– Within first 100 hours	15-2	– Adjusting front wheel tread	35-1
– After first 100 hours	15-2	– Checking front wheel toe-in	35-4
 		– Adjusting front wheel toe-in	35-4
Operating the Engine	20-	– Rear wheel tread adjustment	35-6
– Prestarting check	20-1	Tires	35-10
– Starting the engine	20-2	– Tire pressures	35-10
– Cold weather starting aids	20-2	– Service tires safely	35-10
– Thermostart aid	20-3	– Tire combinations	35-11
– Ether starting aid	20-3	Ballast	35-12
– Starting with a booster battery	20-5	– Measuring rear wheel slip	35-13
– Towing the tractor to start	20-6	– Installing rear wheel weights	35-13
– Towing the tractor	20-6	– Filling tires with liquid ballast	35-15
– Parking the tractor	20-7	– Installing front weights	35-17
– Stopping the engine	20-7	 	
 		Rockshaft and Three-Point Hitch	40-
Operating the Tractor	25-	Rockshaft	40-1
– Reduce fuel consumption	25-1	– Control lever	40-1
– Ground travel speeds	25-3	– Selector lever	40-3
– At desired engine speed	25-3	– Adjusting rate-of-implement drop	40-5
– At rated engine speed	25-4	Three-point hitch	40-5
– Shifting transmission gears	25-11	– Draft links	40-6
– Hi-Lo shift unit	25-12	– Center link	40-8
– Creeper transmission	25-12	– Lift links	40-9
– Front wheel drive	25-13	– Attaching implements	40-11
– Differential lock	25-13	– Positioning sway blocks	40-12
– Foot brakes	25-14		
– Trailer brakes	25-14		

Contents

Additional Equipment	45-	Service – Engine	75-
Front hitch	45-1	– Engine oil	75-1
Selective control valves	45-1	– Engine crankcase filter element	75-2
– Hydraulic hose couplers	45-3	– Alternator V-belt tension	75-2
– Maximum permissible oil withdrawal	45-6	– Checking engine speeds	75-3
Remote hydraulic cylinder	45-7		
Swinging drawbar	45-8	Service – Cooling System	80-
Trailer hitch	45-9	– Checking coolant level	80-1
Hydraulic trailer hitch	45-11	– Replacing coolant	80-2
Power Take-Off	50-	Service – Axles and Wheels	85-
– PTO guard	50-1	– Lubricating front axle	85-1
– Operating PTO	50-2	– Checking front axle oil levels	85-2
– Changing PTO shaft	50-3	– Lubricating rear axle bearings	85-2
– Hand shift PTO	50-4	– Changing front axle oil	85-3
– Operating front PTO	50-4		
– Attaching PTO driven equipment	50-5	Service – Fuel System	90-
		– Checking fuel filter element	90-1
Fuel, Lubricants, Hydraulic		– Replacing fuel filter element	90-1
Oil and Coolant	55-	– Bleeding the fuel system	90-2
Fuel	55-1	– Draining water trap	90-2
– Fuel storage	55-1		
Fluid for hydraulically operated clutch	55-1	Service – Transmission/Hydraulic System	95-
Lubricants	55-2	– Checking oil level	95-1
– Engine oil	55-2	– Replacing filter element	95-1
– Transmission/hydraulic oil	55-2	– Changing transmission/hydraulic oil	95-2
– Front axle oil	55-3		
– EP multipurpose grease	55-3	Service – Miscellaneous	100-
– Engine coolant	55-4	– Checking clutch pedal free travel	
		(mechanically operated clutch)	100-1
Lubrication and Periodic Service	60-	– Checking clutch reservoir fluid level	
– Service intervals	60-1	(hydraulically operated clutch)	100-1
– Removing radiator grille screens	60-1	– Operator’s seat	100-1
– Removing hood	60-1	Cab air filters	
– Service timetable	60-2	– SG2 cab	100-2
		– MC1 cab	100-3
Service – Air Intake System	65-	– Clutch throw-out bearing	100-3
– Air cleaner	65-1	– Hydraulic trailer hitch	100-4
– Cleaning primary air filter element	65-1	– 3-point hitch	100-4
– Secondary (safety) element	65-2	– Compressor V-belt	100-5
– Air pre-cleaner	65-3	– Front hitch	100-5
– Dust unloading valve	65-3	– Front PTO	100-5
– Air intake hoses	65-3	– Replacing hydrostatic steering filter	100-5
Service – Brakes	70-		
– Bleeding brakes	70-1		
– Adjusting handbrake	70-2		

Contents

Service – Electrical System	105-	Specifications	125-
– Batteries	105-1	– Engine	125-1
– Starting motor	105-5	– Permissible axle loads and weights	125-2
– Alternator	105-6	– Electrical system	125-3
– Fuses	105-7	– Capacities	125-3
Service – Heater and Air Conditioning System	110-	Serial Numbers	130-
Tractor Storage	115-	Lubrication and Maintenance Records	135-
– Storage	115-1		
– Removing tractor from storage	115-2		
 		Index	140-
Trouble Shooting	120-		
– Hydraulic system	120-1		
– Engine	120-2		
– Electrical system	120-3		

INHOM-1640CLE-010386

Safety (Operation)

PTO DRIVE

High-inertia implements do not become stationary immediately when PTO control lever is shifted to disengaged position. Allow sufficient time for implement to "coast down" to a halt after having disengaged the PTO.

Make sure PTO drive shaft guards are installed.

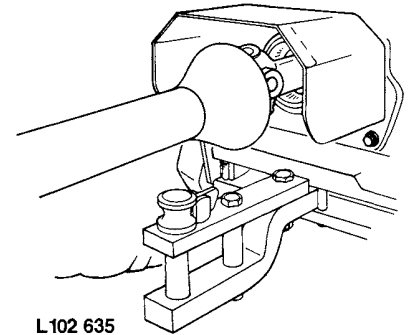

L102 635

L102635-2140ALE-010885

PARKING THE TRACTOR

Before leaving the tractor lower any equipment to the ground.

When parking on a slope, place chock behind a rear wheel.

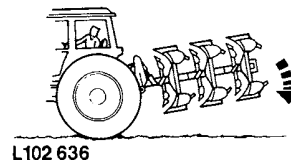

L102 636

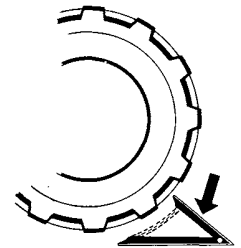

L102 637 A

L102636,L102637A-2140ALE-010885

HANDLE FUEL SAFELY – AVOID FIRES

Handle fuel with care, it is highly flammable. Do not refuel the machine while smoking or when near open flame or sparks.

Always stop engine before refueling the machine. Fill fuel tank outdoors.

Prevent fires by keeping machine clean off accumulated trash, grease and debris. Always clean up spilled fuel.



TS 185

AB6-TS185 053-FIRE1 240785

NOISE PROTECTION

Prolonged exposure to loud noise can cause impairment or loss of hearing.

Wear a suitable hearing protective device such as earmuffs (A) or earplugs (B) to protect against objectionable or uncomfortable loud noises.



X7662



X7662-2140ALE-010885

SAFETY ON PUBLIC ROADS



CAUTION: Always comply with local traffic regulations when driving on public roads.



H28930-2140ALE-010885

HANDLE CHEMICALS PROPERLY

The operator's cab body air filters (A) are not designed to filter out harmful chemicals. Follow instructions given in the implement operator's manual and those given by the chemical manufacturer when using agricultural chemicals.

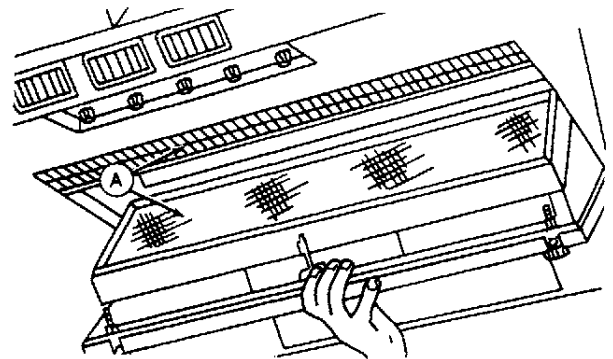

AJ7-RW5704L U01-SAX1 18 151282

SERVICE TIRES SAFELY

Failure to follow proper procedures when mounting a tire on a wheel or rim can produce an explosion which may result in serious bodily injury or death. DO NOT attempt to mount a tire unless you have the proper equipment and experience to perform the job safely. Have it done by your JOHN DEERE dealer or a qualified tire repair service.

When sealing tire beads on rims, never exceed maximum inflation pressures specified by tire manufacturers for mounting tires. Inflation beyond this maximum pressure may break the bead, or even the rim, with dangerous explosive force. If both beads are not seated when the maximum recommended pressure is reached, deflate, reposition tire, relubricate bead and reinflate.

Detailed agricultural tire mounting instructions, including necessary safety precautions, are contained in John Deere Fundamentals of Service (FOS) Manual 55, Tires and Tracks, available through your JOHN DEERE dealer. Such information is also available from your local tire manufacturer agents.

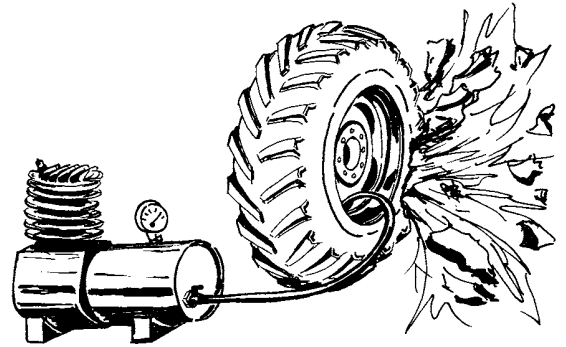

Z 20924

Z20924-2140ALE-010885

DISCONNECTING ELECTRICAL CIRCUIT

Disconnect battery ground strap before carrying out any electrical repairs on the tractor. See also under important notes for "Alternator" in section "Service - Electrical System".

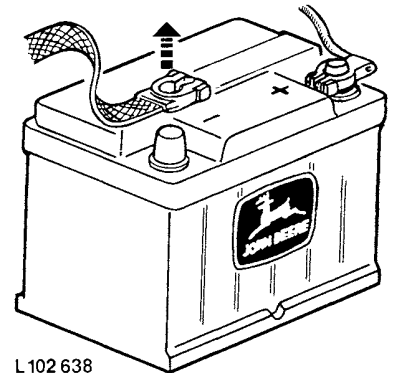

L 102 638

L102638-2140ALE-010885

Safety (Operation)

OPERATING THE ENGINE

Never operate the engine in a closed building. Danger of asphyxiation!

When starting the engine rockshaft control lever must be in "lower" position.

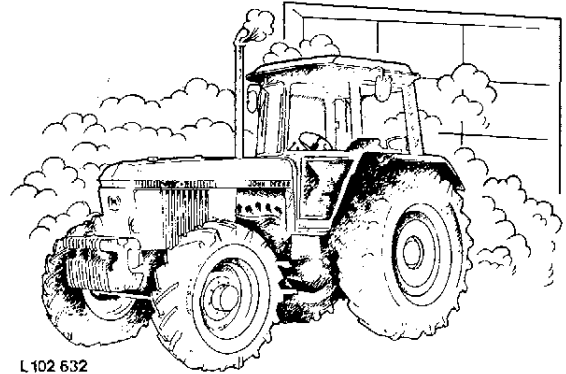

L 102 632

L102632-2140ALE-010885

DRIVING THE TRACTOR

Reduce ground speed when driving the tractor on slopes or uneven ground and before making sharp turns. Before descending a steep hill, shift to a lower gear. Never coast downhill!

Avoid holes ditches and obstructions which may cause the tractor to tip, particularly on hillsides.

Front-wheel drive (A) greatly increases traction. This means that the tractor can be driven on steeper slopes, increasing the possibility of a tip over.

Never drive near the edge of a gully or steep embankment, it might cave in!

Driving forward out of a ditch or up a steep slope could cause tractor to tip over to the rear. Therefore reverse out of these situations whenever possible (B).

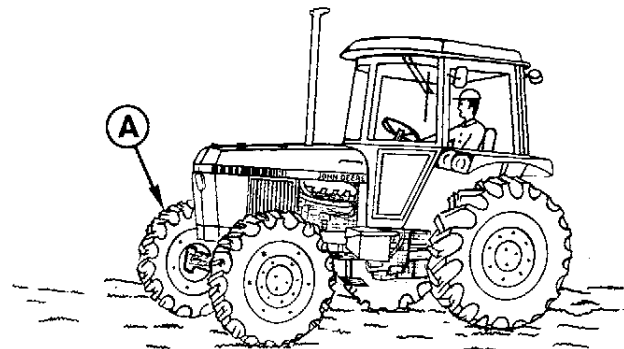

L 104 647



L 104 648

L104647,L104648-3040ALE-010285

ROLL GUARD

A protective roll guard is incorporated in the operator's cab. On this construction, as well as on the roll guard on tractors without an operator's cab, do not, under any circumstances, modify structural members by welding on additional parts, drilling holes, grinding etc. Disregarding this instruction reduces stability of the roll guard.

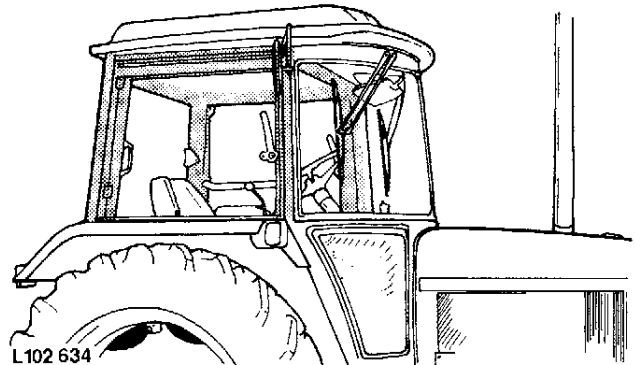

L102 634

L102634-2140ALE-010885

Controls and Instruments

Tractors with SG2 Cab

- A—Windshield wiper switch, left-hand
- B—Air conditioning switch
- C—Fan switch
- D—Heater switch
- E—Windshield wiper switch, right-hand

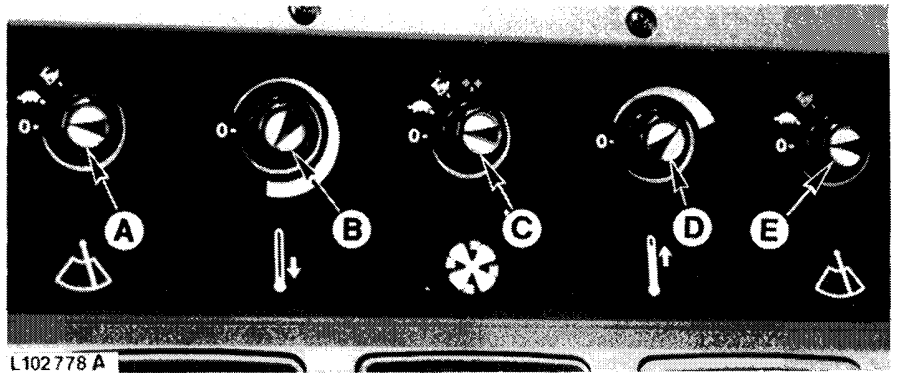

L102778A-1640ALE-010386

Tractors with MC1 Cab

- A—Windshield wiper switch
- B—Fan switch (upper)
- C—Fan switch (lower)
- D—Heater switch

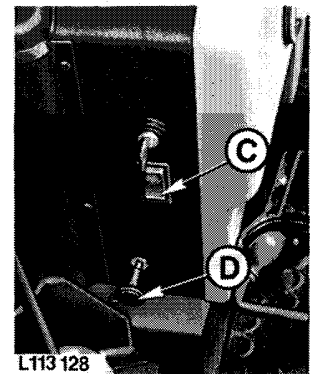
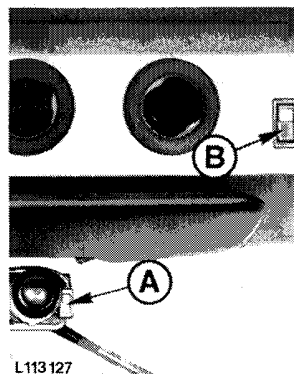

L113127,L113128-1640ALE-010386

FUEL GAUGE

The fuel gauge shows the amount of fuel in tank, from "full" (4/4) to "empty" (0).

NOTE: Never run fuel tank completely dry, otherwise you will have to bleed the fuel system.

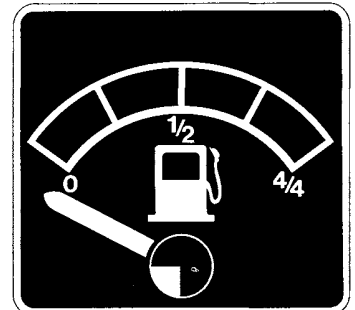

L102646-2140ALE-010885

COOLANT TEMPERATURE GAUGE

Should the coolant gauge needle move into the red zone (A) the engine is overheating. Immediately reduce load or shift to a lower gear. Should the needle remain in the red zone, shut-off engine and determine cause of overheating (coolant level low or dirty radiator).

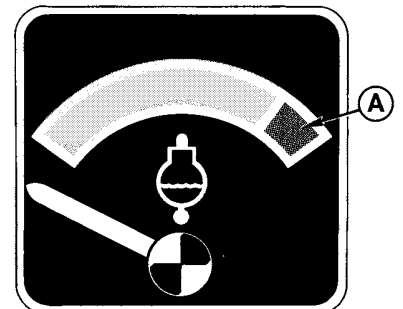

L102647-2140ALE-010885

Safety (Service)

SERVICE – GENERAL

Do not service the tractor while the engine is running.

Reinstall all shields and guards removed for servicing and make sure they are in a servicable condition.

Have adjustments carried out by trained personnel only.

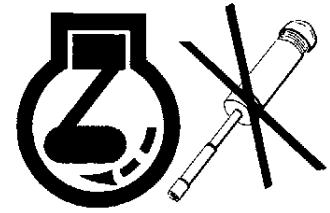

Z 20 919

Z20919-2140ALE-010885

AVOID HIGH-PRESSURE FLUIDS

Escaping fluid under pressure (fuel or hydraulic oil) can penetrate the skin causing serious injury. Relieve pressure before disconnecting hydraulic or other lines. Tighten all connections before applying pressure. Keep hands and body away from pin holes and nozzles which eject fluids under high pressure. Use a piece of cardboard or wood to search for leaks. Do not use your hand.

If any fluid is injected into the skin, consult a doctor immediately, otherwise this may result in a serious infection.

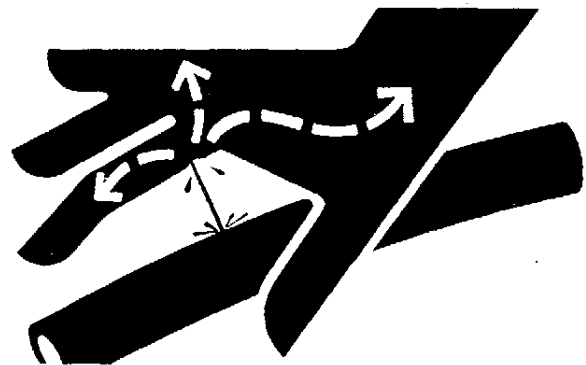

L 102 134

L102134-2140ALE-010885

SERVICE COOLING SYSTEM SAFELY

Remove radiator cap carefully when engine is hot. With engine shut off, turn radiator cap to first stop to relieve pressure before removing it completely.

Top up radiator with coolant with engine stationary.

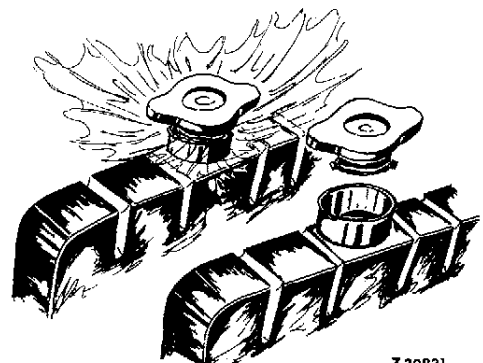

Z 20921

Z20921-2140ALE-010885

SERVICE TIRES SAFELY

Failure to follow proper procedures when mounting a tire on a wheel or rim can produce an explosion which may result in serious bodily injury or death. **DO NOT** attempt to mount a tire unless you have the proper equipment and experience to perform the job safely. Have it done by your JOHN DEERE dealer or a qualified tire repair service.

When sealing tire beads on rims, never exceed maximum inflation pressures specified by tire manufacturers for mounting tires. Inflation beyond this maximum pressure may break the bead, or even the rim, with dangerous explosive force. If both beads are not seated when the maximum recommended pressure is reached, deflate, reposition tire, relubricate bead and reinflate.

Detailed agricultural tire mounting instructions, including necessary safety precautions, are contained in John Deere Fundamentals of Service (FOS) Manual 55, Tires and Tracks, available through your JOHN DEERE dealer. Such information is also available from your local tire manufacturer agents.

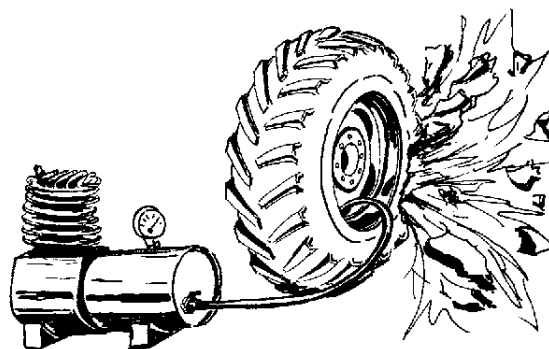

Z 20924

Z20924-2140ALE-010885

DISCONNECTING ELECTRICAL CIRCUIT

Disconnect battery ground strap before carrying out any electrical repairs on the tractor. See also under important notes for "Alternator" in section "Service - Electrical System".

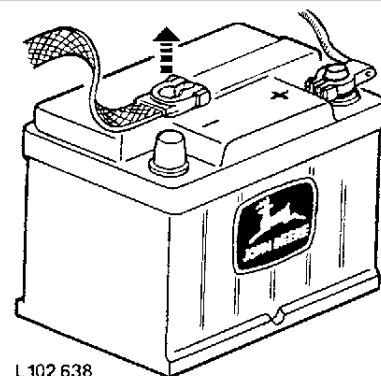

L102 638

L102638-2140ALE-010885

Controls and Instruments

1-Standard Tractors or Tractors With MC1 Cab

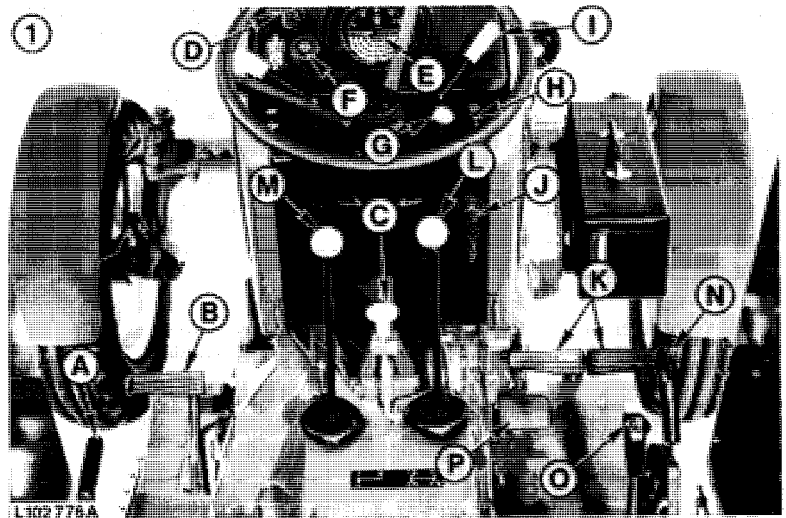

- A-Handbrake
- B-Clutch pedal
- C-PTO shift lever
- D-Turn signal switch
- E-Speed-hour meter
- F-Hazard warning light switch
- G-Engine shut-off knob
- H-Starter switch
- I-Hand throttle lever
- J-Main switch
- K-Brake pedals
- L-Gear shift lever
- M-Range shift lever
- N-Rockshaft control lever
- O-Selective control valve lever
- P-Foot throttle

2-Tractors With SG2 Cab

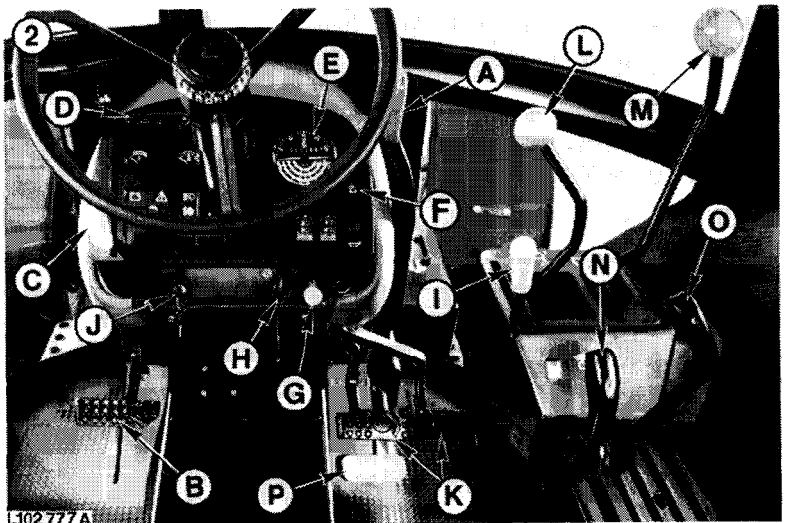

L102776A,L102777A-1640ALE-010386

Controls and Instruments

Tractors with SG2 Cab

- A-Windshield wiper switch, left-hand
- B-Air conditioning switch
- C-Fan switch
- D-Heater switch
- E-Windshield wiper switch, right-hand

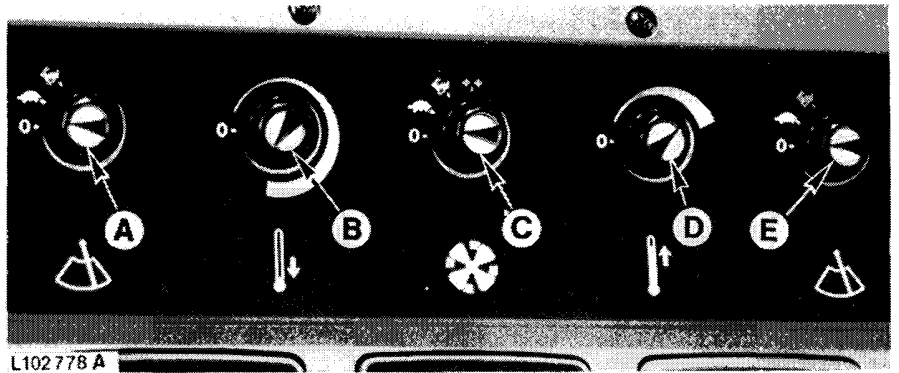

L102 778 A

L102778A-1640ALE-010386

Tractors with MC1 Cab

- A-Windshield wiper switch
- B-Fan switch (upper)
- C-Fan switch (lower)
- D-Heater switch

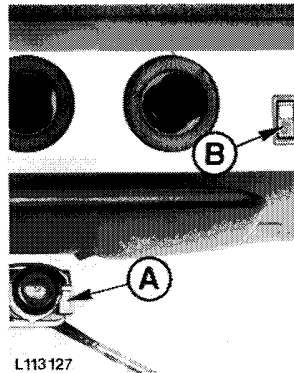

L113 127

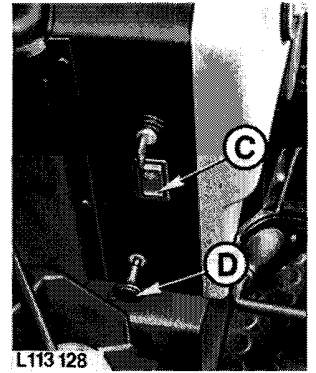

L113 128

L113127,L113128-1640ALE-010386

FUEL GAUGE

The fuel gauge shows the amount of fuel in tank, from "full" (4/4) to "empty" (0).

NOTE: Never run fuel tank completely dry, otherwise you will have to bleed the fuel system.

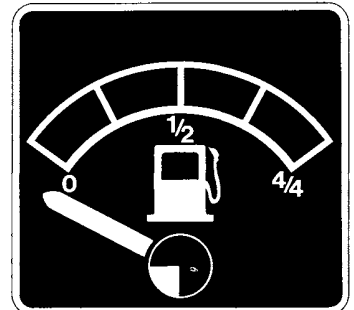

L102 646

L102646-2140ALE-010885

COOLANT TEMPERATURE GAUGE

Should the coolant gauge needle move into the red zone (A) the engine is overheating. Immediately reduce load or shift to a lower gear. Should the needle remain in the red zone, shut-off engine and determine cause of overheating (coolant level low or dirty radiator) .

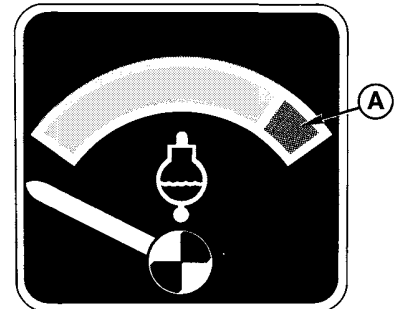

L102 647

L102647-2140ALE-010885

CONTROL LIGHTS

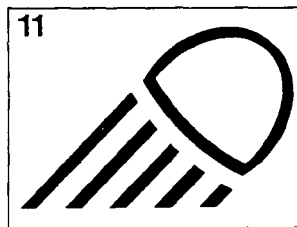
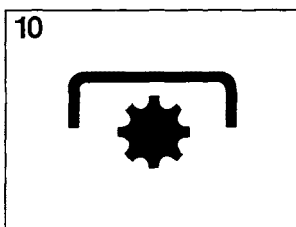
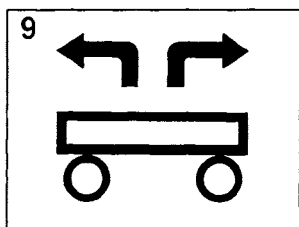
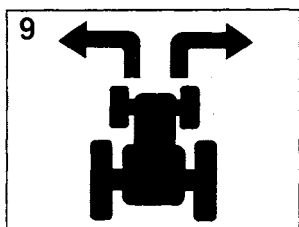
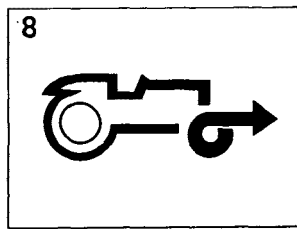
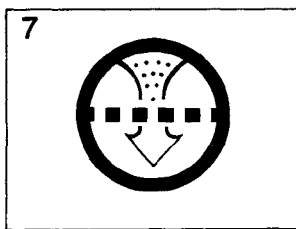
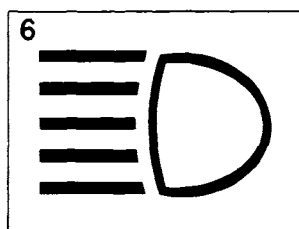
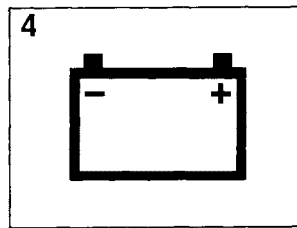
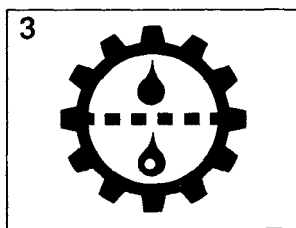
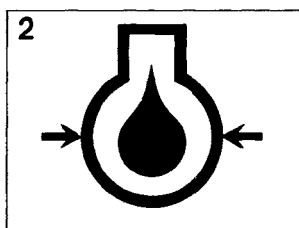

L102 779

1 – The handbrake indicator light glows when handbrake is applied and main switch is turned on. In addition, an acoustical warning signal can be installed.

2 – If engine oil pressure indicator light glows with engine running, shut-off engine and check oil level.

3 – If transmission oil pressure indicator light glows during tractor operation, stop tractor and check transmission/hydraulic oil level. Should indicator light glow and oil level is correct, then oil filter is clogged. Replace filter.

4 – If alternator indicator light glows with engine running, this indicates a defect at alternator. Check alternator cable connections and tension of V-belt. If necessary, have alternator checked by your JOHN DEERE dealer.

5 – The warning light blinks when indicator lights 2, 3 or 4 glow or when the range shift lever is moved with the handbrake applied.

6 – The full-beam indicator light will glow as soon as the full-beam headlights are switched on.

7 – If air cleaner indicator light glows with engine running, the air cleaner element must be cleaned or replaced.

8 – The front wheel drive indicator light glows when the front wheel drive is engaged.

9 – The flashing indicator lights for tractor and trailer start flashing when turn-signal or hazard warning lights are switched on.

10 – The PTO speed indicator lights show speed of PTO engaged (hand shift PTO only).

11 – On tractors with operator's cab there can be one or two indicator lights with this symbol. They glow when work lights are switched on or with additional H3 headlights switched on (tractors with front hitch only).

NOTE: Indicator lights 2, 3, 4 and 7 should glow as soon as the main switch is turned on. If this is not the case, a defective bulb or blown fuse may be the cause. Check and replace parts as necessary. On tractors equipped with collar-shift transmission, indicator light 3 glows only when a malfunction occurs.

The indicator lights should go out as soon as the engine is running.

L102779-2140ALE-010885



Suggest:

If the above button click is invalid.

Please download this document

first, and then click the above link

to download the complete manual.

Thank you so much for reading

Break-In Period

AFTER FIRST 4 AND 8 HOURS OF OPERATION

Tighten Rear Wheel Retaining Bolts.
(bolt torques vary depending on tractor equipment)

- A—400 Nm (300 ft-lb)
- B—250 Nm (185 ft-lb)
- C—230 Nm (170 ft-lb)

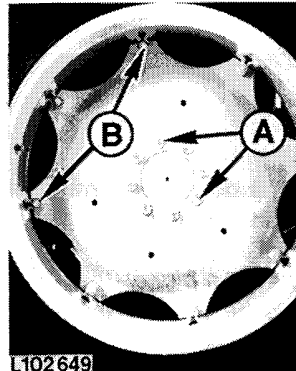

L102649

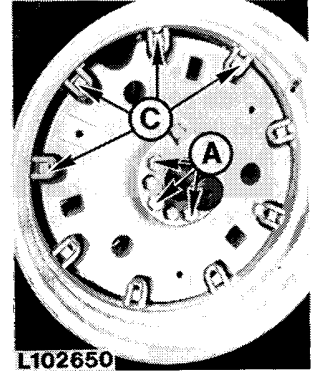

L102650

L1022649,L102650-2140ALE-010885

Tighten Front Wheel Retaining Bolts.
(bolt torques vary depending on tractor equipment)

- A—180 Nm (130 ft-lb)
- B—300 Nm (220 ft-lb)
- C—250 Nm (185 ft-lb)

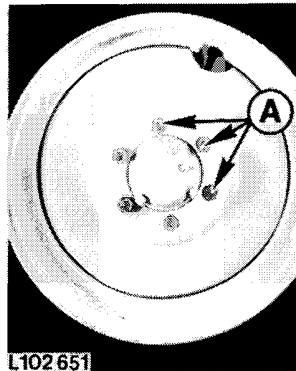

L102651

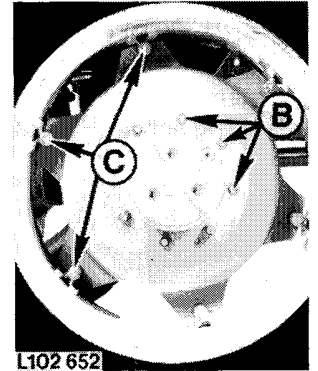

L102652

L102651,L102652-3040ALE-010285

Adjustable Front Axle

Tighten attaching screws (A) with 400 Nm (300 ft-lb) torque.

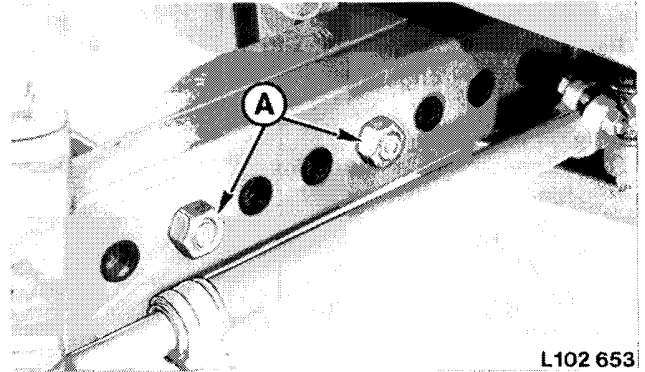

L102653

L102653-2140ALE-010885

AFTER FIRST 50 HOURS OF OPERATION

Replace transmission oil filter (see "Service – Transmission/ Hydraulic System").

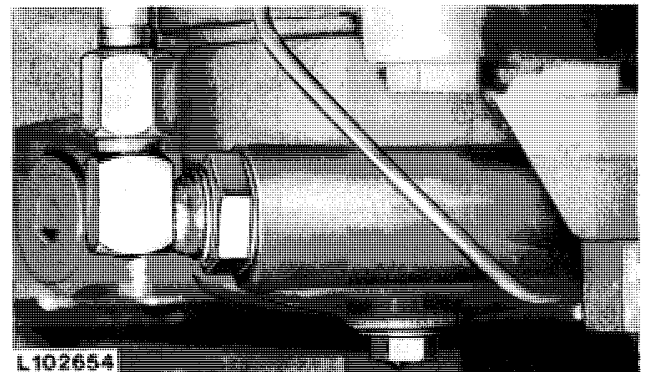

L102654

L102654-2140ALE-010885

<https://www.ebooklibonline.com>

Hello dear friend!

Thank you very much for reading.

Enter the link into your browser.

The full manual is available for immediate download.

<https://www.ebooklibonline.com>