

**JOHN DEERE**  
**WORLDWIDE COMMERCIAL & CONSUMER**  
**EQUIPMENT DIVISION**

---

**Wide Area Mower**  
**1600 Turbo**

OMTCU18439 J3

**OPERATOR'S MANUAL**



**JOHN DEERE**

North American Version  
Litho in U.S.A.

# INTRODUCTION

---

## Thank You for Purchasing a John Deere Product

We appreciate having you as a customer and wish you many years of safe and satisfied use of your machine.

## Using Your Operator's Manual

This manual is an important part of your machine and should remain with the machine when you sell it.

Reading your operator's manual will help you and others avoid personal injury or damage to the machine.

Information given in this manual will provide the operator with the safest and most effective use of the machine. Knowing how to operate this machine safely and correctly will allow you to train others who may operate this machine.

If you have an attachment, use the safety and operating information in the attachment operator's manual along with the machine operator's manual to operate the attachment safely and correctly.

This manual and safety signs on your machine may also be available in other languages (see your authorized dealer to order).

Sections in your operator's manual are placed in a specific order to help you understand all the safety messages and learn the controls so you can operate this machine safely. You can also use this manual to answer any specific operating or servicing questions. A convenient index located at the end of this book will help you to find needed information quickly.

The machine shown in this manual may differ slightly from your machine, but will be similar enough to help you understand our instructions.

RIGHT-HAND and LEFT-HAND sides are determined by facing in the direction the machine will travel when going forward. When you see a broken line (-----), the item referred to is hidden from view.

Before delivering this machine, your dealer performed a predelivery inspection to ensure best performance.

## Machine Use

This machine is designed as a traction unit, with the intended use as a multi-purpose implement carrier, in the application of turf and highway maintenance, and winter work. Use in any other way is considered as contrary to the intended use.

This mower should be operated, serviced and repaired only by persons familiar with all its particular characteristics and acquainted with the relevant safety rules (accident

prevention). The accident prevention regulations, all other generally recognized regulations on safety and occupational medicine and the road traffic regulations must be observed at all times.

Setting fuel delivery beyond published factory specifications or otherwise overpowering will result in loss of warranty protection for this machine.

Any arbitrary modifications carried out on this machine will relieve the manufacturer of all liability for any resulting damage or injury

## Special Messages

Your manual contains special messages to bring attention to potential safety concerns, machine damage as well as helpful operating and servicing information. Please read all the information carefully to avoid injury and machine damage.



**CAUTION: Avoid injury! This symbol and text highlight potential hazards or death to the operator or bystanders that may occur if the hazards or procedures are ignored.**

**IMPORTANT: Avoid damage! This text is used to tell the operator of actions or conditions that might result in damage to the machine.**

**NOTE: General information is given throughout the manual that may help the operator in the operation or service of the machine.**

# PRODUCT IDENTIFICATION

---

## Record Identification Numbers

### Wide Area Mower 1600 Turbo PIN (TC1600T030001- )

If you need to contact an Authorized Service Center for information on servicing, always provide the product model and identification numbers.

You will need to locate the identification numbers for the product. Record the information in the spaces provided below.

DATE OF PURCHASE:

\_\_\_\_\_

DEALER NAME:

\_\_\_\_\_

DEALER PHONE:

\_\_\_\_\_



MX10674

PRODUCT IDENTIFICATION NUMBER (A):

-----

ENGINE SERIAL NUMBER (B):

-----

**<https://www.ebooklibonline.com>**

Hello dear friend!

Thank you very much for reading.

Enter the link into your browser.

The full manual is available for immediate download.

**<https://www.ebooklibonline.com>**

# TABLE OF CONTENTS

---

Safety .....	1
Operating Machine .....	11
Operating Mower Deck .....	22
Replacement Parts .....	26
Service Intervals .....	27
Service Lubrication .....	28
Service Engine .....	32
Service Transmission .....	43
Service Steering & Brakes .....	48
Service Mower deck .....	49
Service Electrical .....	57
Service Miscellaneous .....	60
Troubleshooting .....	65
Storage .....	68
Specifications .....	69
Warranty .....	71
Index .....	74

All information, illustrations and specifications in this manual are based on the latest information at the time of publication. The right is reserved to make changes at any time without notice.

COPYRIGHT© 2003  
Deere & Co.  
John Deere Worldwide Commercial and  
Consumer Equipment Division  
All rights reserved  
Previous Editions  
COPYRIGHT© 2002

OMTCU18439 J3 - English

# SAFETY

## Understanding The Machine Safety Labels

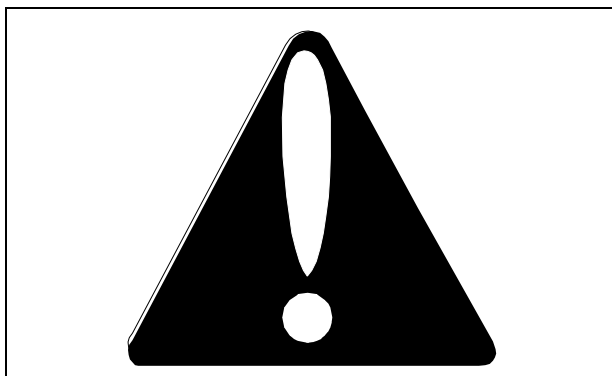

Safety-Alert Symbol

The machine safety labels shown in this section are placed in important areas on your machine to draw attention to potential safety hazards.

On your machine safety labels, the words DANGER, WARNING, and CAUTION are used with this safety-alert symbol. DANGER identifies the most serious hazards.

The operator's manual also explains any potential safety hazards whenever necessary in special safety messages that are identified with the word, CAUTION, and the safety-alert symbol.

## CAUTION

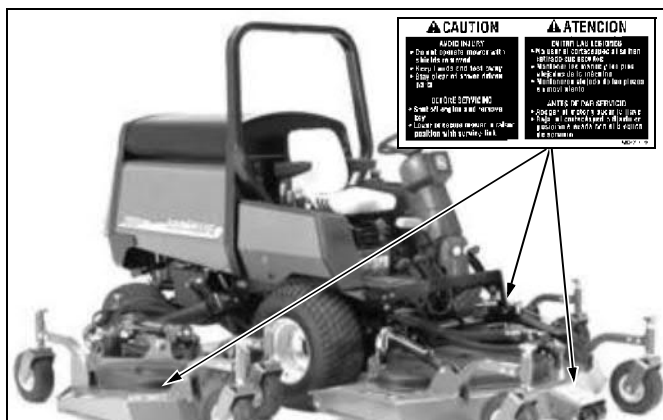

MX10674 MX0438

### AVOID INJURY

- Do not operate mower with shields removed
- Keep hands and feet away
- Stay clear of power driven parts

### BEFORE SERVICING

- Shut off engine and remove key
- Lower or secure mower in raised position with service link

## WARNING



MX10674 MX0440

Hot surface

## CAUTION

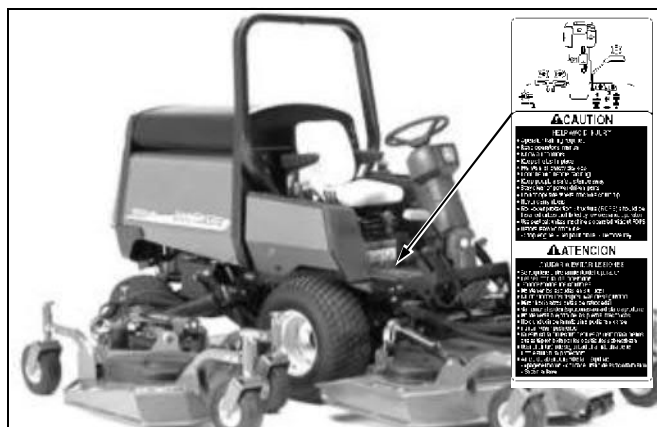

MX10674 MX18655

### HELP AVOID INJURY

- Operator training required
- Read operator's manual
- Know all controls
- Keep shields in place
- Maintain all safety devices
- Look behind before backing
- Keep people a safe distance away
- Stay clear of power driven parts
- Do not operate where machine could tip
- Never carry riders
- Roll-over protection structure (ROPS) should be installed unless prohibited by low clearance operation
- Use seat belt unless machine is operated without ROPS

# SAFETY

- Before leaving machine:
  - Stop engine
  - Set park brake
  - Remove key

## WARNING



MX10674 MX0443

To avoid injury while transporting, keep front attachment low and avoid sharp turns with side attachments in transport position.

To avoid injury, avoid quick stops and reduce speed on slopes.

All wheels drive. To avoid injury from crushing, do not operate with only one axle raised.

## DANGER

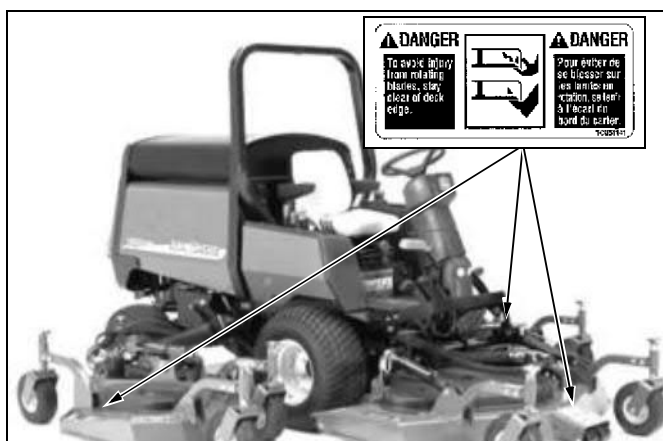

MX10674 MX0489

To avoid injury from rotating blades, stay clear of deck edge.

## WARNING

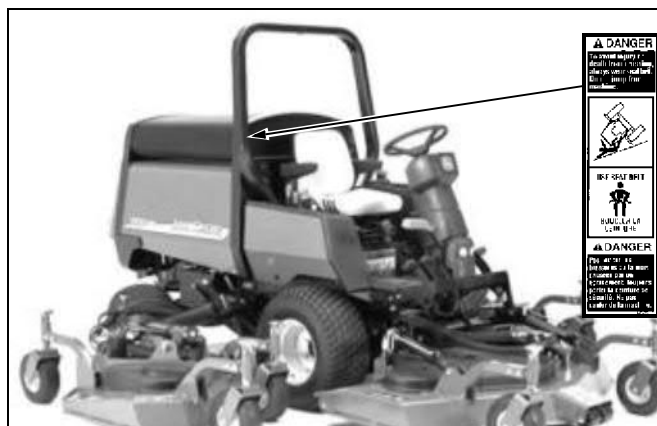

MX10674 MX0483

## USE SEAT BELT

To avoid injury from crushing, always wear seat belt. Do not jump from machine.

## ROLL-OVER PROTECTIVE STRUCTURE



MX10674 MX0487

To maintain operator protection and ROPS certification:

- Replace damaged ROPS, do not repair or revise.
- Any alteration of ROPS must be approved by manufacturer

## CERTIFICATION

Performance certified at date of manufacture to:

OSHA: 29 CFR, Part 1928, Subpart C, John Deere Mowers, Deere & Company, Moline, Illinois

# SAFETY

## DANGER / POISON

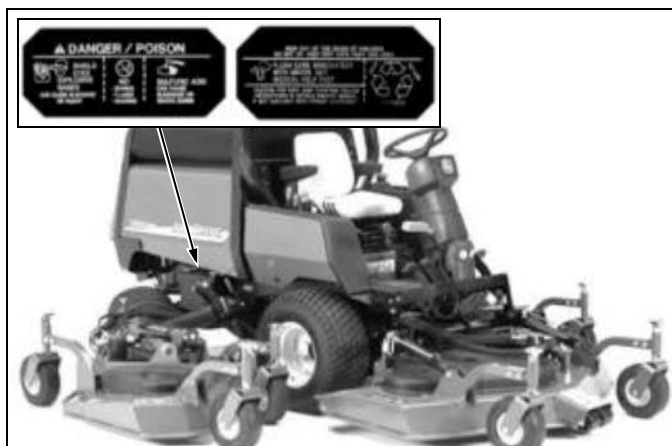

MX10674 MX8853

- Shield eyes. Explosive gases can cause blindness or injury.
- No sparks, flames, smoking.
- Sulfuric acid can cause blindness or severe burns.
- Keep out of the reach of children.
- Do not tip. Keep vent caps tight and level.
- Flush eyes immediately with water. Get medical help fast.
- Caution: For safe jump starting, follow instructions in vehicle owners manual. If not available, seek service assistance.

## IMPORTANT

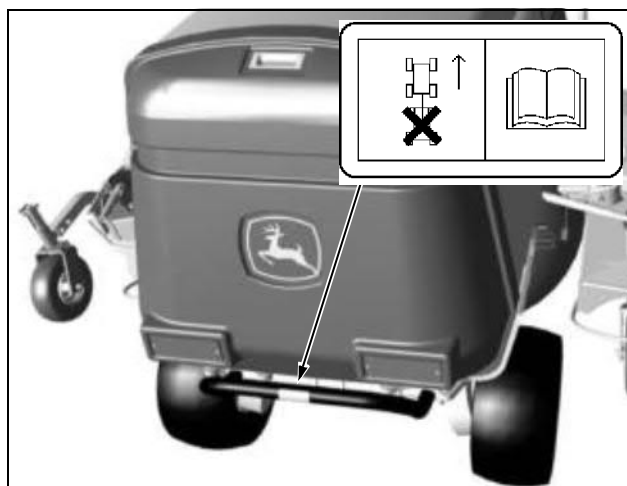

MX18666 MX18665

## NO TOWING

Do not use the hood hinge tube for towing. Machine damage may result.

## Emissions Control System Certification Label (Non-Road Diesel)

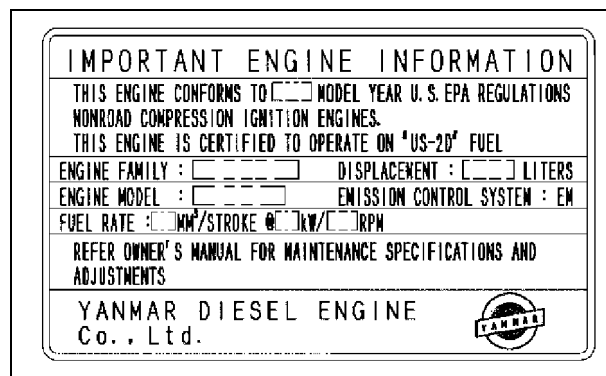

MX5293



**CAUTION: Avoid injury! Statutes providing severe penalties for tampering with emissions controls may apply at the user's location.**

The emissions warranty described in the warranty section applies only to those engines marketed by John Deere that have been certified by the United States Environmental Protection Agency (EPA) and/or California Air Resources Board (CARB); and used in the United States in non-road mobile (self-propelled or portable/transportable<sup>1</sup>) equipment. The presence of an emissions label like the one shown signifies that the engine has been certified with the EPA and/or CARB. The EPA and CARB warranties only apply to new engines having the certification label affixed to the engine and sold as stated above in the geographic areas governed by the regulating agencies.

**NOTE: The hp/kW rating on the engine emissions certification label specifies the gross engine hp/kW, which is flywheel power without fan. In most applications this will not be the same rating as the advertised vehicle hp/kW rating.**

## Certification

Your product has been tested and evaluated by the manufacturer and conforms with American National Standard B-71.4, "Safety Specifications" for commercial turf care equipment.

## Operator Training Required

- The owner of the machine is responsible for training the users and mechanics of the machine.

<sup>1</sup>. Equipment moved at least once every 12 months.

---

# SAFETY

---

- The owner/user can prevent and is responsible for accidents or injuries occurring to themselves, other people, or property.
- Do not allow operation or service of the machine by untrained adults.
- Do not let children operate the machine. Local regulations may restrict the age of the operator.
- Read the operator's manual and study the safety and operation sections before operating the machine.
- If the operator of the machine cannot read or understand this manual, it is the machine's owner responsibility to explain this material to the operator. This publication is available in other languages.
- Operate the machine in an open, unobstructed area under the direction of an experienced operator.
- Learn the use of all controls.
- Operator experience is required to learn the moving, stopping, turning and other operating characteristics of the machine.

## Operating Safely

- Only allow responsible adults, who are familiar with the instructions to operate the machine. Local restrictions may restrict the age of the operator.
- Inspect machine before you operate. Be sure hardware is tight. Repair or replace damaged, badly worn, or missing parts. Replace faulty silencers. Be sure guards and shields are in good condition and fastened in place. Make any necessary adjustments before you operate.
- Before using, always visually inspect to see that the blades, blade bolts and the mower assembly are not worn and damaged. Replace worn and damaged blades and bolts in sets to preserve balance.
- Be sure all drives are in neutral and parking brake is locked before starting engine. Only start engine from the operator's position.
- Do not change the engine governor settings or overspeed the engine. Operating the engine at excessive speed can increase the hazard of personal injury.
- Do not operate mower without discharge chute or entire grass catcher in place. Never operate with the discharge deflector raised, removed, or altered, unless using a grass catcher.
- Check brake action before you operate. Adjust or service brakes as necessary.
- Stop machine if anyone enters the area.
- If you hit an object or if abnormal vibration occurs, stop the machine and inspect it. Make repairs before you operate. Keep machine and attachments properly maintained and in good working order.
- Be aware of the mower discharge direction and make sure that no one is in the path of the discharge direction.
- Do not leave machine unattended when it is running.
- Only operate during daylight or with good artificial light.
- Stop the blades rotating before crossing surfaces other than grass.
- Use only accessories and attachments approved by the manufacturer of the machine. Keep safety labels visible when installing accessories and attachments.
- Do not operate machine if you are under the influence of drugs or alcohol.
- Check before each use that operator presence controls are functioning correctly. Test safety systems. Do not operate unless they are functioning correctly.
- Always wear seat belt if machine has a standard ROPS or a folding ROPS in the upright position.
- Never raise mower decks when blades are running.
- Slow down and be careful of traffic when operating near or crossing roadways. Stop blades before crossing roads or sidewalks. Use care when approaching blind corners, shrubs, trees, or other objects that may obscure vision.
- Do not wear radio or music headphones. Safe service and operation require your full attention.
- Disengage drive to attachments when transporting or not in use.
- Reduce the throttle setting during engine run-out and, if the engine is provided with a fuel shut-off valve, turn the fuel off at the conclusion of mowing.
- When machine is left unattended, stored, or parked, lower the mower deck unless a positive mechanical lock is used.

# SAFETY

## Use Seat Belt Properly

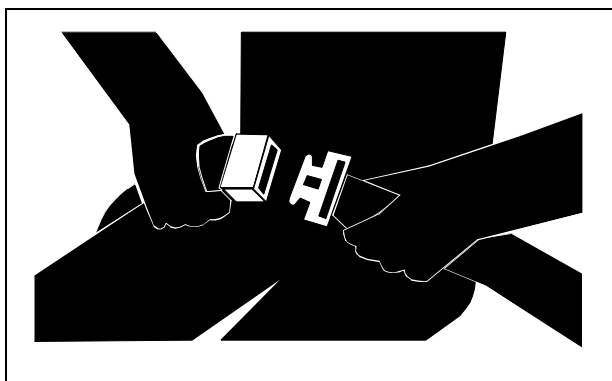

Use a seat belt when you operate with a Roll-Over Protective Structure (ROPS) to minimize chance of injury from an accident, such as an overturn.

Do not use a seat belt if operating with an optional folding ROPS in the folded position.

## Checking Mowing Area

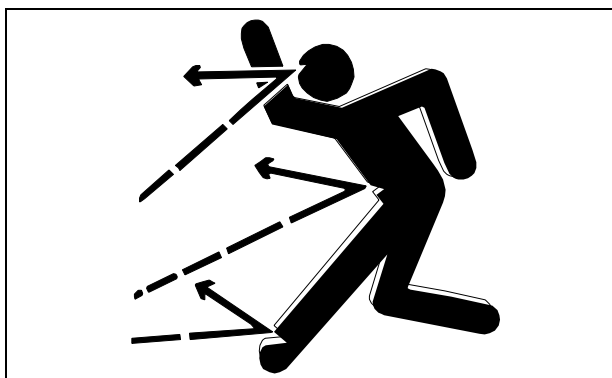

MIF

- Evaluate the terrain to determine what accessories and attachments are needed to properly and safely perform the job.
- Clear work area of objects that might be thrown. Keep people and pets out of mowing area.
- Low-hanging branches and similar obstacles can injure the operator or interfere with mowing operation. Before mowing, identify potential obstacles such as low-hanging branches, and trim or remove those obstacles.
- Study work area. Set up a safe driving pattern. Do not operate attachment where traction or stability is doubtful.

## Rotating Blades are Dangerous

HELP PREVENT SERIOUS OR FATAL ACCIDENTS:

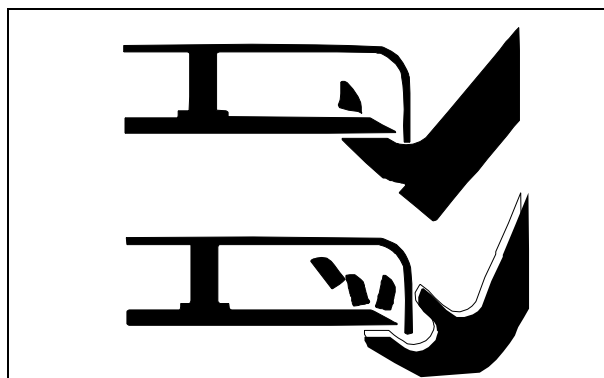

- Rotating blades can cut off arms and legs, and throw objects. Failure to observe safety instructions could result in serious injury or death.
- Keep hands, feet and clothing away from mower deck when engine is running.
- Be alert at all times, drive forward carefully. People, especially children can move quickly into the mowing area before you know it.
- Before backing up, stop mower blades or attachments and look down and behind the machine carefully, especially for children.
- Do not mow in reverse.
- Shut off blades when you are not mowing.
- Park machine safely before leaving the operator's station for any reason including emptying the catchers or unplugging the chute.

## PROTECT CHILDREN:

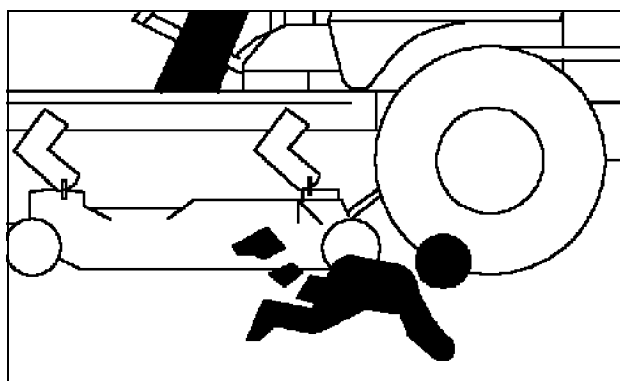

MIF

- Tragic accidents can occur if the operator is not alert to the presence of children. Keep children out of the mowing area and under the watchful care of another responsible adult.

# SAFETY

---

- Never assume that children will remain where you last saw them. Children are attracted to mowing activity, stay alert to the presence of children.
- Keep children indoors when you are mowing. Turn the machine off if a child enters the mowing area.
- Do not let children or an untrained person operate the machine.
- Do not carry or let children ride on any attachment or machine even with the blades off. Do not tow children in a cart or trailer.

## Parking Safely

1. Stop machine on a level surface, not on a slope.
2. Disengage mower blades or any other attachments.
3. Lower attachments to the ground.
4. Lock the park brake.
5. Stop the engine.
6. Remove the key.
7. Wait for engine and all moving parts to stop before you leave the operator's seat.
8. Close fuel shut-off valve, if your machine is equipped.
9. Disconnect the negative battery cable or remove the spark plug wire (for gasoline engines) before servicing the machine.

## Avoid Tipping

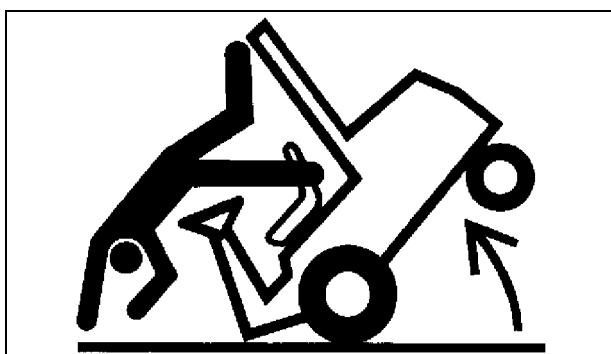

MX0490

- Slopes are a major factor related to loss-of-control and tip-over accidents, which can result in severe injury or death. All slopes require extra caution. If you cannot back up the slope or if you feel uneasy on it, do not mow it.
- Drive up and down a hill - not across.
- Do not mow or operate on slopes you cannot back up.
- Keep all movement on slopes slow and gradual. Do not

make sudden changes in speed or direction.

- Use a slow speed when operating on a slope. Choose a low gear or speed so that you will not have to stop or shift while on the slope.
- Tires may lose traction on slopes even though the brakes are functioning properly.
- Transport machine with decks lowered to improve stability.
- Drive machine very slowly and avoid quick stops when attachment is removed.
- Do not turn on slopes unless necessary. Turn slowly and turn downhill. Do not shift to neutral and coast downhill.
- Stay alert for holes and other hidden hazards in the terrain. Uneven terrain could overturn the machine. Tall grass can hide obstacles.
- Keep away from drop-offs, ditches and embankments. The machine could suddenly turn over if a wheel is over the edge of a cliff or ditch, or if an edge caves in.
- Use extra care with grass catchers or other attachments. These can change the stability of the machine. Do not use grass catcher on steep slopes.
- Follow the manufacturer's recommendations for wheel weights or counterweights for added stability when operating on slopes or using front or rear mounted attachments. Remove weights when not required.
- Do not stop when going up hill or down hill. If machine stops going up hill or tires lose traction, disengage mower blades and back down slowly.
- Operating machine when grass is wet can cause reduced traction and sliding.

## Checking Wheel Bolts

- A serious accident could occur causing serious injury if wheel bolts are not tight.
- Check wheel bolt tightness often during the first 100 hours of operation.
- Wheel hardware must be tightened to specified torque using the proper procedure anytime it is loosened.

# SAFETY

## Keep Riders Off

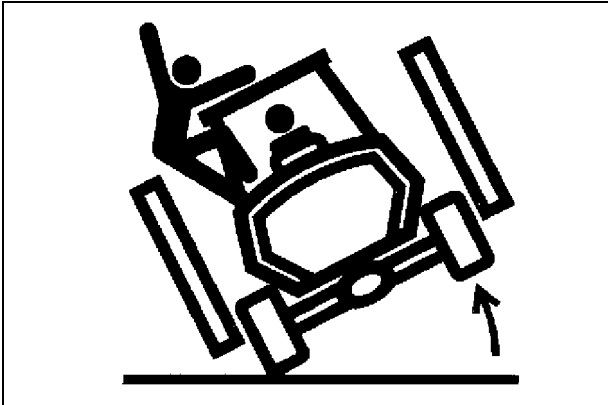

MX0488

- Only allow the operator on the machine. Keep riders off.
- Riders on the machine or attachment may be struck by foreign objects or thrown off the machine causing serious injury.
- Riders obstruct the operator's view resulting in the machine being operated in an unsafe manner.

## Wear Appropriate Clothing

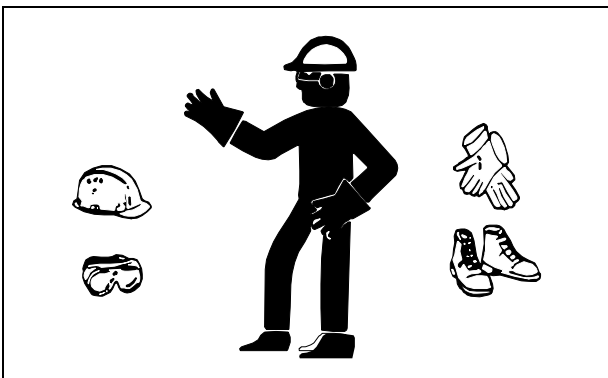

MIF

- Always wear safety goggles, or safety glasses with side shields, and a hard hat when operating the machine.
- Wear close fitting clothing and safety equipment appropriate for the job.
- While mowing, always wear substantial footwear and long trousers. Do not operate the equipment when barefoot or wearing open sandals.
- Wear a suitable protective device such as earplugs. Loud noise can cause impairment or loss of hearing.

## Driving Safely on Public Roads

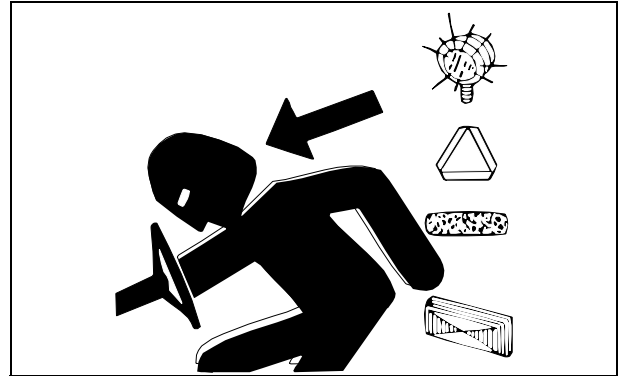

Avoid personal injury or death resulting from a collision with another vehicle on public roads:

- Use safety lights and devices. Slow moving machines when driven on public roads are hard to see, especially at night.
- Whenever driving on public roads, use flashing warning lights and turn signals according to local regulations. Extra flashing warning lights may need to be installed.

## Prevent Fires

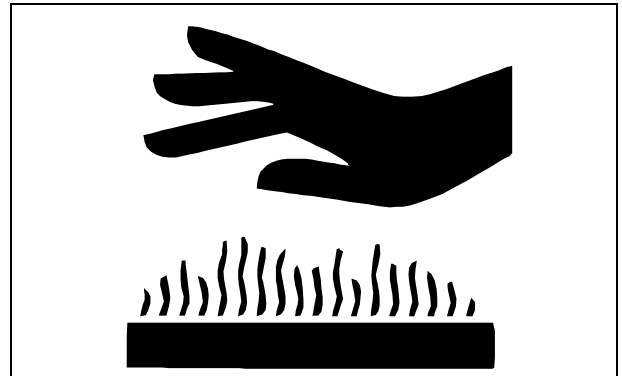

- Remove grass and debris from engine compartment and muffler area, before and after operating machine, especially after mowing or mulching in dry conditions.
- To reduce fire hazard, keep engine and engine compartment free of grass, leaves, or excessive grease.
- Clean up oil or fuel spillage.
- Allow engine to cool before storing in any enclosure.
- Never remove fuel cap, or add fuel with engine running or hot. Allow engine to cool for several minutes.
- Never store equipment with fuel in the tank inside a building where fumes may reach an open flame or spark.

# SAFETY

- Always shut off fuel when storing or transporting machine.

## Handling Fuel Safely

Fuel and fuel vapors are highly flammable:



- Do not refuel machine while you smoke, when machine is near an open flame or sparks, or when engine is running. Stop engine and allow to cool before filling.
- Never remove the fuel cap or add fuel with the engine running.
- Replace all fuel tanks and container caps securely.
- Never fill fuel tank or drain fuel from a machine in an enclosed area. Fill fuel tank outdoors.
- Prevent fires. Clean up spilled fuel immediately. If fuel is spilled on clothing, change clothing immediately. Do not attempt to start the engine but move the machine away from the area of spillage and avoid creating any source of ignition until fuel vapors have dissipated.
- Do not store fuel in container or machine with fuel in tank in a building where fumes may reach an open flame or spark.
- Prevent fire and explosion caused by static electric discharge. Use only non-metal, portable fuel containers approved by the Underwriter's Laboratory (U.L.) or the American Society for Testing & Materials (ASTM). If using a funnel, make sure it is plastic and has no screen or filter.



- Static electric discharge can ignite gasoline vapors in an ungrounded fuel container. Remove the fuel container from the bed of a machine or trailer or the trunk of a car and place on the ground away from the machine before filling. Keep nozzle in contact with container opening while filling. Do not use a nozzle lock-open device.
- When practical, remove equipment from trailers or truck beds and refuel them on the ground. If this is not possible, use a portable, plastic fuel container to refuel equipment on a truck bed or trailer.
- For gasoline engines, do not use gas with methanol. Methanol is harmful to your health and to the environment.

## Practice Safe Maintenance



MIF

- Only qualified, trained adults should service this machine.
- Understand service procedure before doing work. Keep area clean and dry.
- Do not operate the engine in a confined space where dangerous carbon monoxide fumes can collect.
- Never lubricate, service, or adjust machine while it is moving. Wait for all movement to stop on machine before

# SAFETY

adjusting, cleaning or repairing.

- Keep safety devices in place and in working condition. Keep hardware tight.
- On multi-bladed machines, take care as rotating one blade can cause other blades to rotate.
- Keep hands, feet, clothing, jewelry, and long hair away from any moving parts, to prevent them from getting caught.
- Lower attachments to the ground before cleaning or servicing machine. Disengage all power and stop the engine. Lock park brake and remove the key. Let machine cool.
- Disconnect battery or remove spark plug wire (for gasoline engines) before making any repairs.
- Before servicing machine, carefully release pressure from any components with stored energy, such as hydraulic components.
- Keep all nuts and bolts tightened, especially blade attachment bolts.
- Securely support any machine elements that must be raised for service work. Use jack stands or lock service latches to support components when needed.
- Never run engine unless park brake is locked.
- Use care when checking blades. Wrap blades or wear gloves and use caution when servicing them. Only replace blades. Never straighten or weld them.
- Keep all parts in good condition and properly installed. Fix damage immediately. Replace worn or broken parts. Replace all worn or damaged safety and instruction decals.
- Grass catcher components are subject to wear, damage, and deterioration which could expose moving parts or allow objects to be thrown. Check components frequently and replace with manufacturer's recommended parts when necessary.
- Charge batteries in an open, well-ventilated area, away from sparks. Unplug battery charger before connecting or disconnecting from the battery. Wear protective clothing and use insulated tools.
- Do not modify machine or safety devices. Unauthorized modifications may impair its function and safety.
- Check brake operation frequently. Adjust and service as needed.

## Avoid High Pressure Fluids



MIF

- Hydraulic hoses and lines can fail due to physical damage, kinks, age, and exposure. Check hoses and lines regularly. Replace damaged hoses and lines.
- Hydraulic fluid connections can loosen due to physical damage and vibration. Check connections regularly. Tighten loose connections.
- Escaping fluid under pressure can penetrate the skin causing serious injury. Avoid the hazard by relieving pressure before disconnecting hydraulic or other lines. Tighten all connections before applying pressure.
- Search for leaks with a piece of cardboard. Protect hands and body from high pressure fluids.
- If an accident occurs, see a doctor immediately. Any fluid injected into the skin must be surgically removed within a few hours or gangrene may result. Doctors unfamiliar with this type of injury should reference a knowledgeable medical source. Such information is available from Deere & Company Medical Department in Moline, Illinois, U.S.A. Information may be obtained in the United States and Canada only by calling 1-800-822-8262.

## Tire Safety



Explosive separation of a tire and rim parts can cause

# SAFETY

---

serious injury or death:

- Do not attempt to mount a tire without the proper equipment and experience to perform the job.
- Always maintain the correct tire pressure. Do not inflate the tires above the recommended pressure. Never weld or heat a wheel and tire assembly. The heat can cause an increase in air pressure resulting in a tire explosion. Welding can structurally weaken or deform the wheel.
- When inflating tires, use a clip-on chuck and extension hose long enough to allow you to stand to one side and NOT in front of or over the tire assembly.
- Check tires for low pressure, cuts, bubbles, damaged rims or missing lug bolts and nuts.

## Handling Waste Product and Chemicals

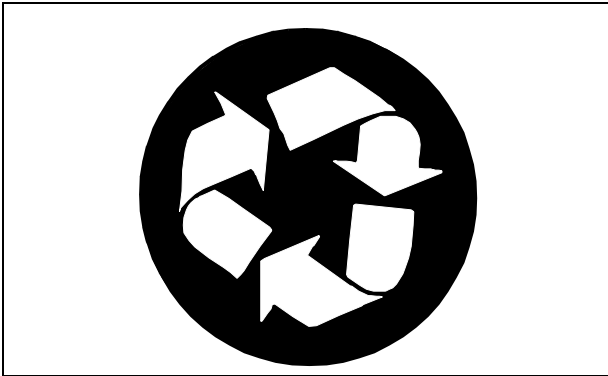

Waste products, such as, used oil, fuel, coolant, brake fluid, and batteries, can harm the environment and people:

- Do not use beverage containers for waste fluids - someone may drink from them.
- See your local Recycling Center or authorized dealer to learn how to recycle or get rid of waste products.
- A Material Safety Data Sheet (MSDS) provides specific details on chemical products: physical and health hazards, safety procedures, and emergency response techniques. The seller of the chemical products used with your machine is responsible for providing the MSDS for that product.

# OPERATING MACHINE

## Daily Operating Checklist

- Test safety systems.
- Check tire pressure.
- Check fuel level.
- Check engine, transmission, and hydraulic oil levels.
- Remove grass and debris from engine compartment and muffler area, before and after operating machine.
- Clean air intake screen.
- Check area below machine for leaks.
- Check air restriction indicator.
- Check engine coolant level.

## Avoid Damage to Plastic and Painted Surfaces

- Do not wipe plastic parts unless rinsed first.
- Insect repellent spray may damage plastic and painted surfaces. Do not spray insect repellent near machine.
- Be careful not to spill fuel on machine. Fuel may damage surface. Wipe up spilled fuel immediately.
- Prolonged exposure to sunlight will damage the hood surface.

## Operator Station Controls

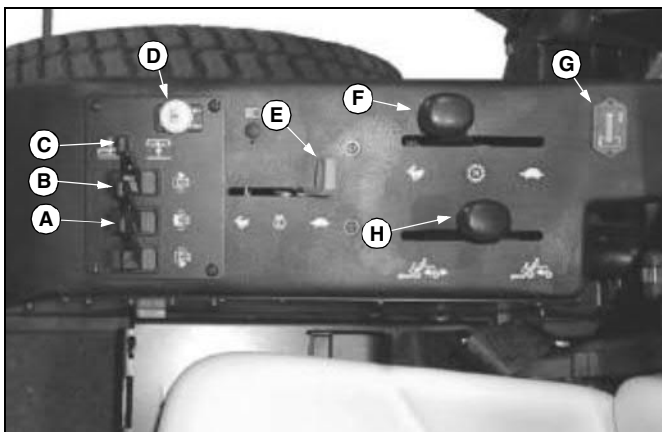

MX18656

- A - Left Mower Deck Lift Lever**
- B - Front Mower Deck Lift Lever**
- C - Right Mower Deck Lift Lever**
- D - PTO Switch**
- E - Throttle Lever**
- F - Speed Range Lever**

**G - Hour Meter**

**H - Four Wheel Drive Lever**

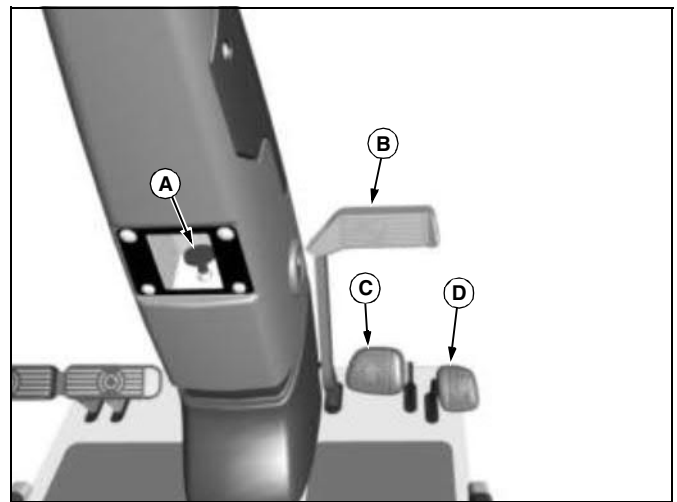

MX13886

**A - Park Brake Knob**

**B - Park Brake Pedal**

**C - Forward Drive Pedal**

**D - Reverse Drive Pedal**

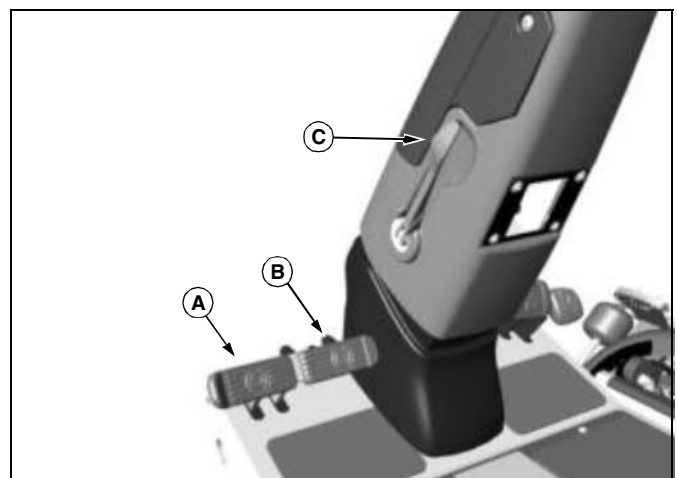

MX13886

**A - Left Turn Brake Pedal**

**B - Right Turn Brake Pedal**

**C - Steering Column Tilt Lock**

# OPERATING MACHINE

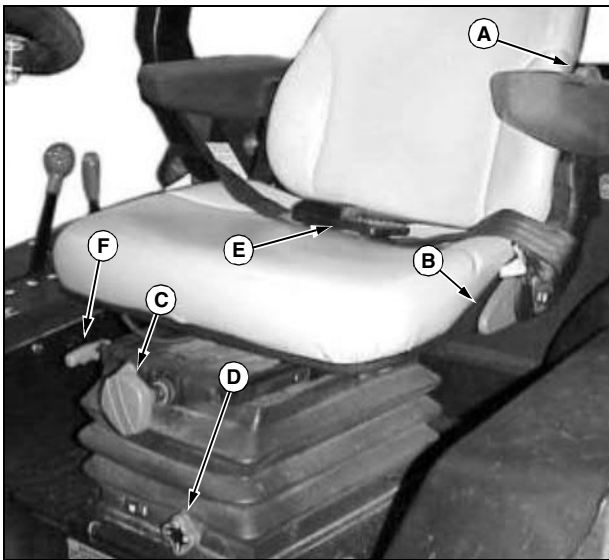

MX5286

- A - Lumbar Support Adjustment
- B - Backrest Tilt Lever
- C - Seat Spring Adjustment Knob
- D - Seat Height Adjustment Knob
- E - Seat Belt
- F - Seat Adjustment Lever

## Miscellaneous Controls

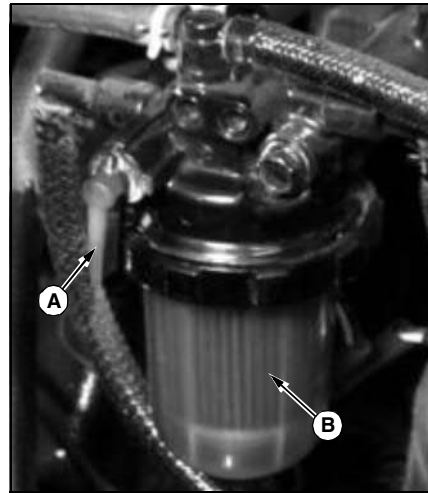

MX0450

- A - Fuel Shutoff Valve
- B - Fuel Filter/Water Separator

## Instrument Panel

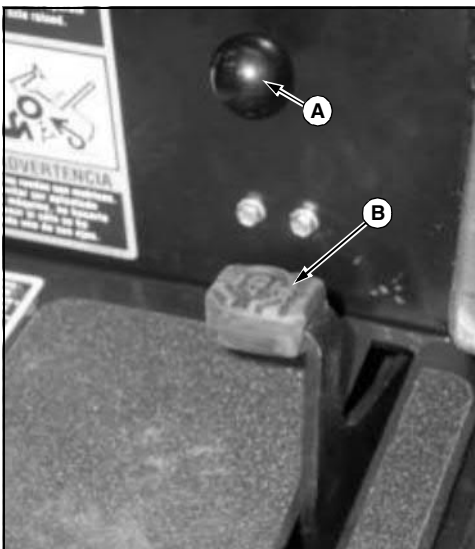

MX13887

- A - Seat Platform Release Knob
- B - Differential Lock

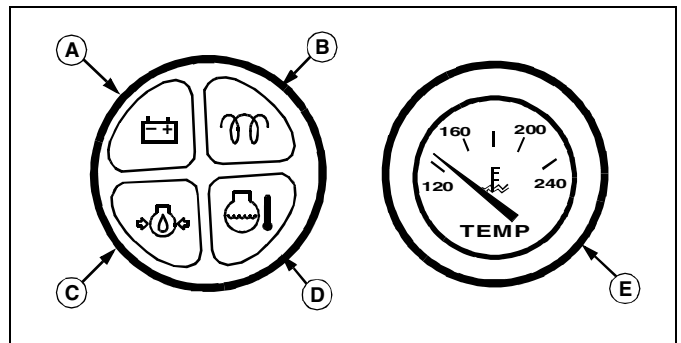

MIF

- A - Battery Discharge Lamp
- B - Engine Manifold Heater Lamp
- C - Engine Oil Pressure Lamp
- D - Engine Coolant Temperature Lamp
- E - Engine Coolant Temperature Gauge

# OPERATING MACHINE

## Testing Safety Systems

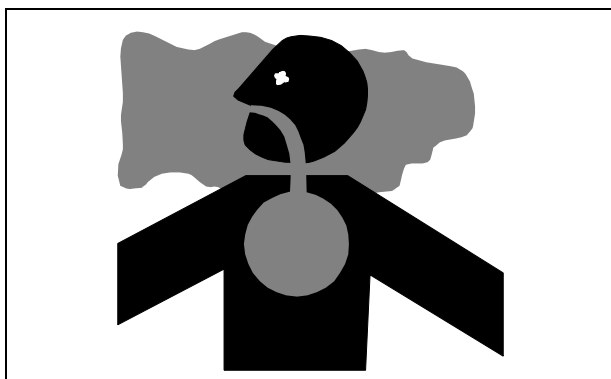

**CAUTION: Avoid injury! Engine exhaust fumes contain carbon monoxide and can cause serious illness or death.**

**Move the machine to an outside area before running the engine.**

**Do not run an engine in an enclosed area without adequate ventilation.**

- **Connect a pipe extension to the engine exhaust pipe to direct the exhaust fumes out of the area.**
- **Allow fresh outside air into the work area to clear the exhaust fumes out.**

The safety systems installed on your machine should be checked before each machine use. Be sure you have read the machine operator manual and are completely familiar with the operation of the machine before performing these safety system checks.

Use the following checkout procedures to check for normal operation of machine.

If there is a malfunction during one of these procedures, do not operate machine. **See your authorized dealer for service.**

Perform these tests in a clear open area. Keep bystanders away.

## Testing PTO Switch

1. Sit on the seat.
2. Lock the park brake.
3. Pull PTO switch up to the on position.
4. Try to start the engine.

**Result:** Engine must not start. If engine starts, there is a problem with your safety interlock circuit.

5. Unlock park brake. Try and start engine.

**Result:** Engine must not start. If engine starts, there is a problem with your safety interlock circuit.

## Testing Seat and Park Brake Switch

1. Sit on seat.
2. Push the PTO switch down to the off position.
3. Unlock the park brake.
4. Start the engine.
5. Raise up off of the seat, but do not get off of the machine.

**Result:** The engine should stop. If engine does not stop, there is a problem with your safety interlock circuit.

## Testing Park Brake

1. Stop the machine on a 17° slope (30% grade). Stop the engine and lock the park brake.
2. Put transmission in N (neutral).
3. Check to be sure the park brake will hold the machine without rolling.

**Result:** The park brake must prevent machine from moving. If machine moves, brakes need to be adjusted. See your John Deere Distributor.

# OPERATING MACHINE

## Getting On and Off of Machine

**NOTE:** Always get on and off from left side of machine to avoid bumping controls and pedals.



MX0466

1. Place right foot on mower deck (A) and use steering wheel to balance yourself while stepping up onto machine.
2. Use step on lift arm (B) to get up to operator's platform.

## Adjusting Seat

To adjust seat position:



MX5286

1. Pull seat adjustment lever (A) up, out of locked position.
2. Slide seat forward or rearward to desired position.

3. Release lever.

To adjust seat backrest:

1. Pull up backrest tilt lever (B), while moving backrest to most comfortable position. Release lever to lock backrest in place.
2. Turn lumbar support knob (C) rearward to increase lumbar support, or forward to decrease support.

To adjust seat spring tension:

**NOTE:** Adjustment must be made with operator off seat.

1. Turn seat spring adjustment knob (D) to the right to decrease seat spring tension, or to the left to increase tension.
2. Sit on operator's seat and turn seat height adjustment knob (E) to one of the following positions to set limits on how high the seat will travel:
  - 0 – Lowest position
  - I – Medium low position
  - II – Medium high position
  - III – Highest position

## Using Seat Belt

Fasten Belt



**CAUTION: Avoid injury!**

- Use a seat belt when you operate with a Roll-Over Protective Structure (ROPS) to minimize chance of injury from an accident, such as an overturn.



**Suggest:**

**If the above button click is invalid.**

**Please download this document**

**first, and then click the above link**

**to download the complete manual.**

**Thank you so much for reading**

# OPERATING MACHINE

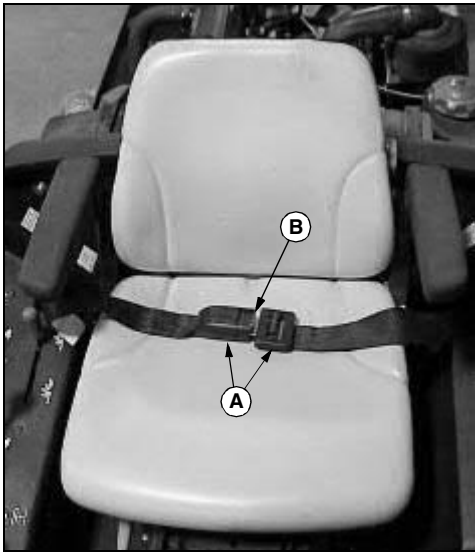

MX5285

- Connect both ends of the seat belt (A) until they click together. Loosen or tighten seat belt until operator is firmly held onto the seat.

## Release Belt

- Press red button (B) to release seat belt.

## Using PTO Switch

**NOTE:** Starter will not crank if PTO is engaged. PTO will disengage when master brake pedal is depressed.

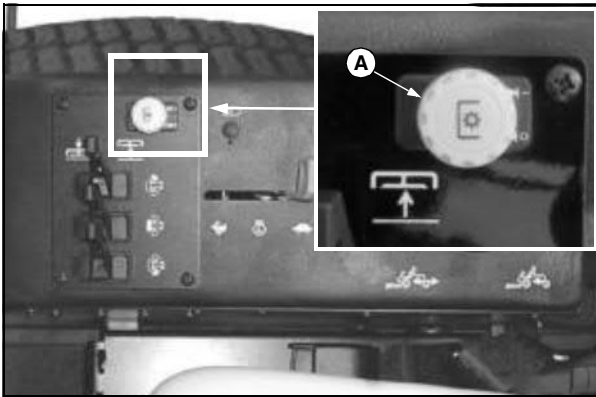

MX5267, MX18656

- Pull PTO knob (A) up to engage the PTO.
- Push PTO knob (A) down to disengage the PTO.

## Using Key Switch

**NOTE:** Starter will not crank if any of the following conditions exist:

- PTO is engaged.

- Hydrostatic drive pedals are not in centered (neutral) position.
- Park brake is not locked and operator is out of seat.

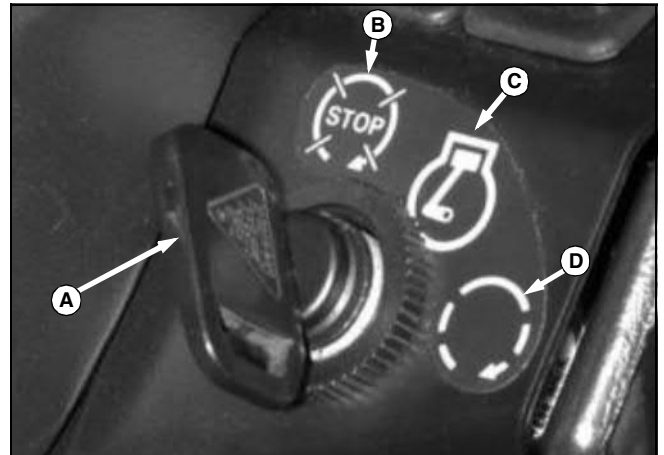

MX13889

- To turn ignition off, turn the key switch (A) to the stop position (B).
- To turn ignition on, turn key switch to the run position (C). Indicator lights on instrument panel should go on, and beeper will sound.
- To start engine, wait for engine manifold heater light to turn off, turn key switch to the start position (D). Once engine begins to run, release key switch back to the run position.

**IMPORTANT:** Avoid damage! Allow engine to idle for five minutes before shutting down to avoid damage to turbocharger.

## Using Throttle Lever

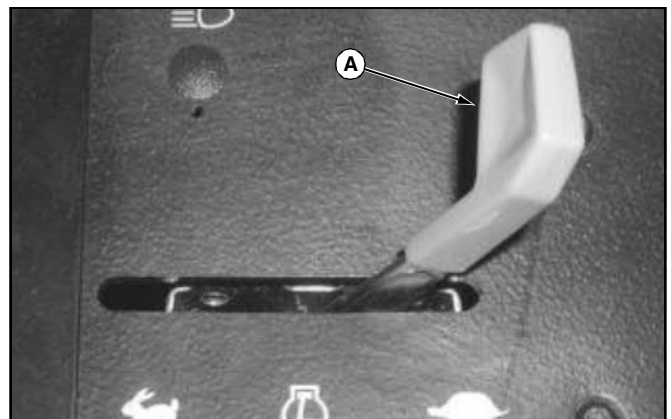

MX18657

- Pull the throttle lever (A) to the rear for slow idle. Use this position to start engine and maneuver the mower in confined spaces.

**<https://www.ebooklibonline.com>**

Hello dear friend!

Thank you very much for reading.

Enter the link into your browser.

The full manual is available for immediate download.

**<https://www.ebooklibonline.com>**