

# 830 Tractor



JOHN DEERE

## OPERATORS MANUAL

830  
Tractor

OML29383 F3 English

John Deere Tractor Works  
OML29383 F3

LITHO IN U.S.A.  
ENGLISH





## To the Purchaser

This new tractor was carefully designed and manufactured to give years of dependable service. To keep it running efficiently, read the instructions in this operator's manual. Each section is clearly identified so you can easily find the information you need—whether it is operation, lubrication and periodic service, or trouble shooting. Check the Contents to learn where each section is located. Use the alphabetical index for fast reference.

Record your tractor serial numbers in the spaces provided below. Your dealer needs this information to give you prompt, efficient service of parts. If your tractor requires replacement parts, go to your John Deere dealer where you can obtain genuine John Deere parts—accept no substitutes.

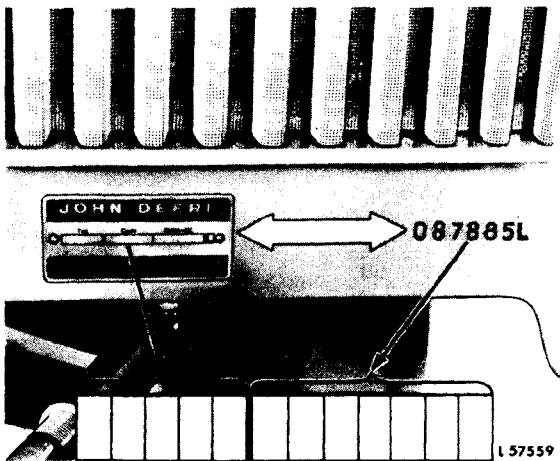

Record Tractor Serial Number here

The warranty on this tractor appears on your copy of the purchase order which you should have received from your dealer when you purchased the tractor.

The references in this manual to the "right-hand" and the "left-hand" sides of the tractor are determined by facing in the direction of tractor forward travel.

 This safety alert symbol indicates important safety messages in this manual. When you see this symbol, be alert to the possibility of personal injury and carefully read the message that follows.

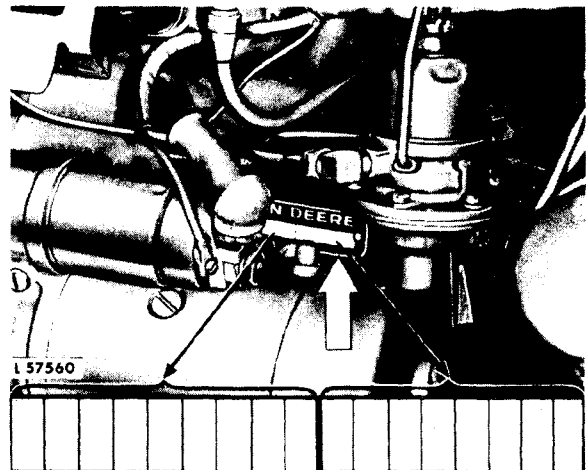

Record Engine Serial Number here



# Contents

---

	Page
CONTROLS AND INSTRUMENTS .....	2
OPERATION .....	4
SAFETY RULES .....	31
FUELS AND LUBRICANTS .....	33
LUBRICATION AND PERIODIC SERVICE .....	35
SERVICE .....	49
TRACTOR STORAGE .....	61
TROUBLE SHOOTING .....	62
SPECIFICATIONS .....	67
INDEX .....	70

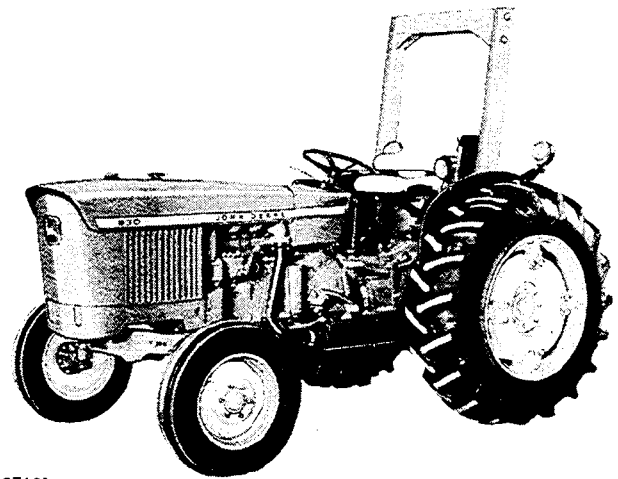
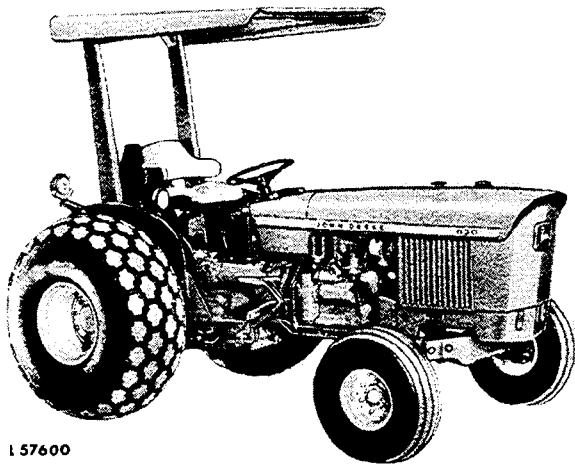

**<https://www.ebooklibonline.com>**

Hello dear friend!

Thank you very much for reading.

Enter the link into your browser.

The full manual is available for immediate download.

**<https://www.ebooklibonline.com>**



# Controls and Instruments

Before attempting to operate your new tractor, become familiar with the location and purpose of its controls and instruments. Study the next few pages carefully, regardless of your previous tractor experience.

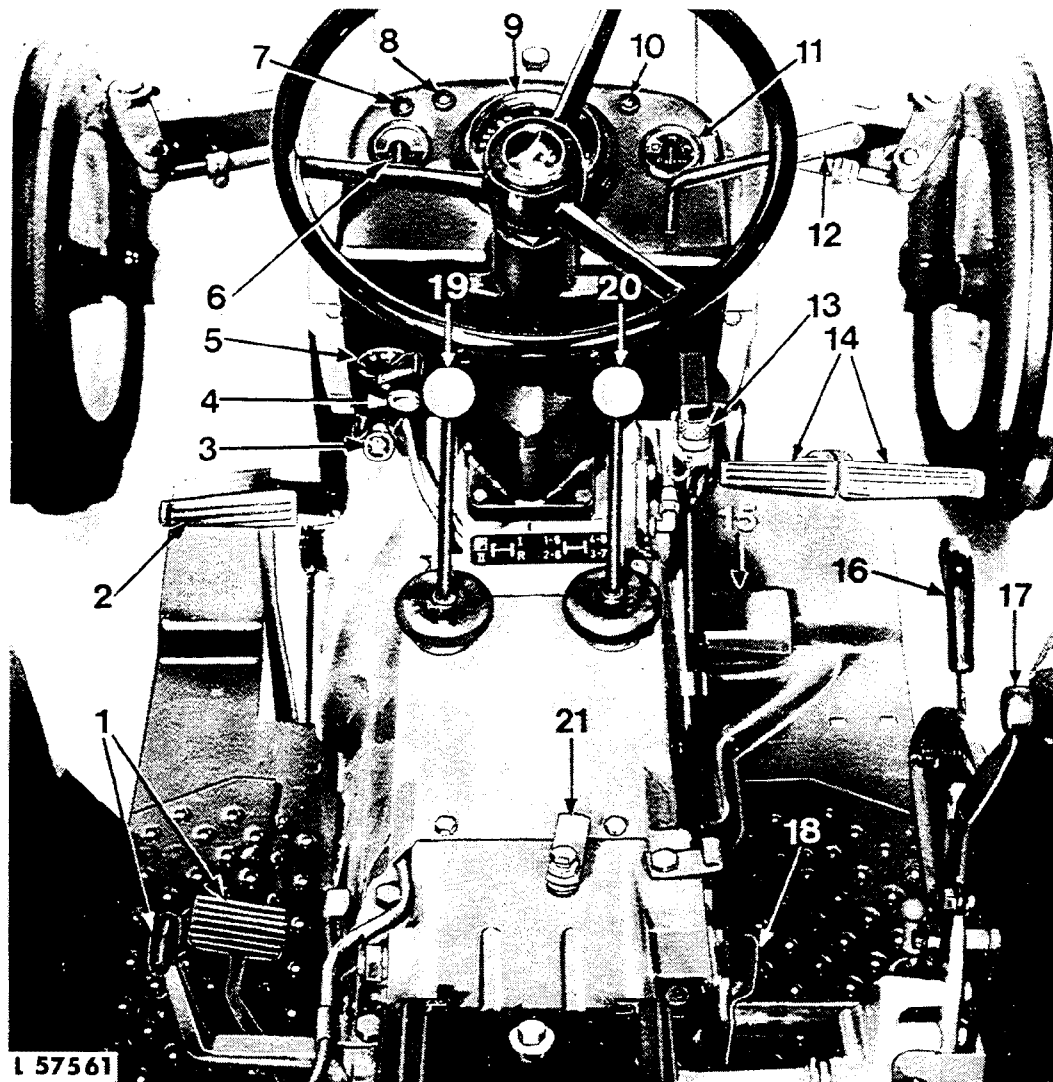

- 1—Differential Lock (Lever and Pedal)
- 2—Clutch Pedal
- 3—Engine Shut-Off Knob
- 4—Starter Switch
- 5—Light Switch
- 6—Coolant Temperature Gauge
- 7—Air Cleaner Indicator Light

- 8—Alternator Indicator Light
- 9—Speed-Hour Meter
- 10—Engine Oil Pressure Indicator Light
- 11—Fuel Gauge
- 12—Hand Throttle
- 13—Starting Fluid Adapter
- 14—Brake Pedals

- 15—Foot Throttle
- 16—Rockshaft Control Lever
- 17—Selective Control Valve Lever
- 18—Rockshaft Selector Lever
- 19—Range Shift Lever
- 20—Gear Shift Lever
- 21—Rate-of-Drop Lever

## INSTRUMENTS

### Control Lights

#### Alternator



L 56 968

#### Engine Oil Pressure



L 56 966

The above control lights should light up as soon as switch key is moved clockwise to first position. If this is not the case, a burnt-out bulb may be the cause. If necessary, replace defective bulb.

The control lights should go out as soon as the engine is running and the engine speed has been raised. If this is not the case or if a light goes on during operation, immediately shut off engine and correct the problem.

If alternator indicator light goes on during engine operation, the alternator is not charging. Check for loose alternator connections, slackness of V-belt, or defective alternator.

If engine oil pressure indicator light goes on during engine operation, stop the engine, check oil level and condition of engine oil filter.

#### Air Cleaner Indicator Light



L 56 955

If air cleaner indicator light goes on, clean air filter element or replace element after it has been cleaned six times.

### Coolant Temperature Gauge

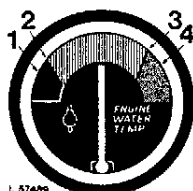

L 57489

- 1—100°F (38°C)
  - 2—135°F (57°C)
  - 3—224°F (107°C)
  - 4—240°F (116°C)
- Orange warning zone

If the gauge needle is in the orange warning zone, the engine is overheating and must be stopped at once. Check coolant level in radiator and check cooling system for leaks.

### Fuel Gauge

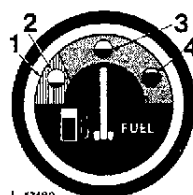

L 57490

- 1—Orange Warning Zone
- 2—Empty Tank
- 3—Half-Full Tank
- 4—Full Tank

The fuel gauge shows the amount of fuel in tank, from "empty" to "half-full" and "full".

Refill tank as soon as needle points to orange zone.

Never run fuel tank completely dry.

### Speed-Hour Meter

The speed-hour meter facilitates the economical use of the tractor under all operating conditions. It also facilitates choosing the right gear.

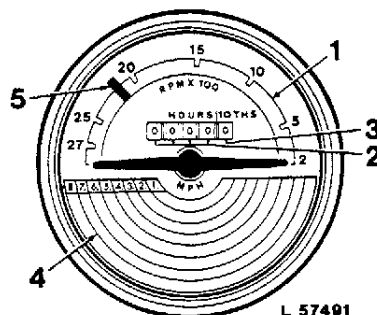

L 57491

The speed-hour meter shows the following:

- 1—Engine speed on the upper half of the dial. The figure shown multiplied by 100 indicates the actual number of engine revolutions.
- 2—Hours of operation in full hours.
- 3—Hours of operation in tenths of hours.

The hour meter facilitates close observation of the proper service intervals.

- 4—The tractor speed for the gear engaged.
- 5—PTO operation. The green mark shows the engine speed required for powershaft operation.



# Operation

## PRE-STARTING INSPECTION

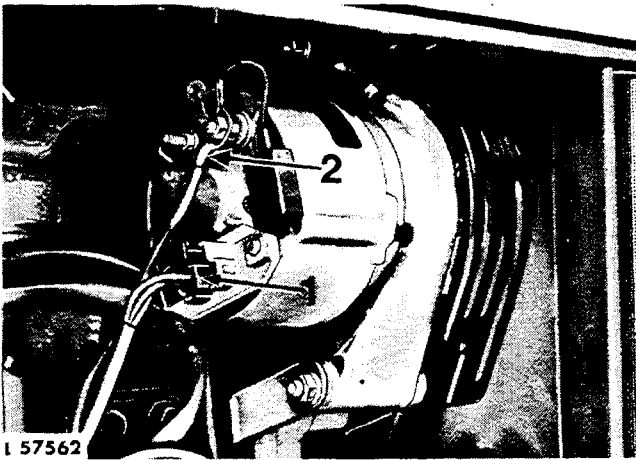

Prior to operating tractor for the first time, connect three-terminal plug 1 and red cable 2 to alternator.

**IMPORTANT:** If the tractor is to be operated without battery (using a slave battery for starting), do not, under any circumstances, interrupt the circuit by switching off the starter switch before stopping engine by means of fuel pump stop cable. Having stopped the engine, switch off starter switch and remove key. It is also recommended to use additional current (lights) while engine is running.

Connect slave battery in the proper polarity (negative to ground).

Further details about the alternator are given on page 55.

The following items must be checked daily before commencing work:

### Oil Level in Engine Crankcase

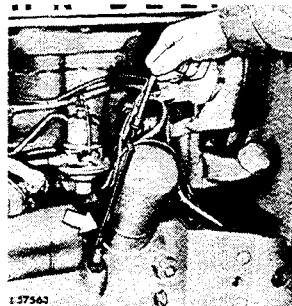

If oil level has dropped to bottom mark on dipstick, add sufficient oil to bring oil level up to top mark on dipstick.

See page 34 for correct oil.

### Radiator Coolant Level

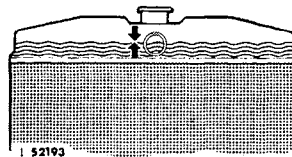

Coolant should be maintained at a level midway between radiator core and filler neck.

See "Cooling System" section for correct coolant mixture.

### Fuel Filter



Drain all water and dirt deposits from fuel filter.

The drain plug is located at the bottom of the filter body.

### Fuel Shut-Off Valve

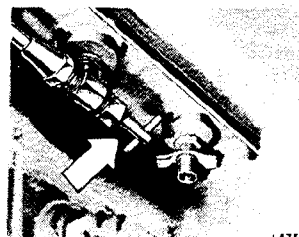

Make sure fuel shut-off valve located under fuel tank is open.

## STARTING THE ENGINE

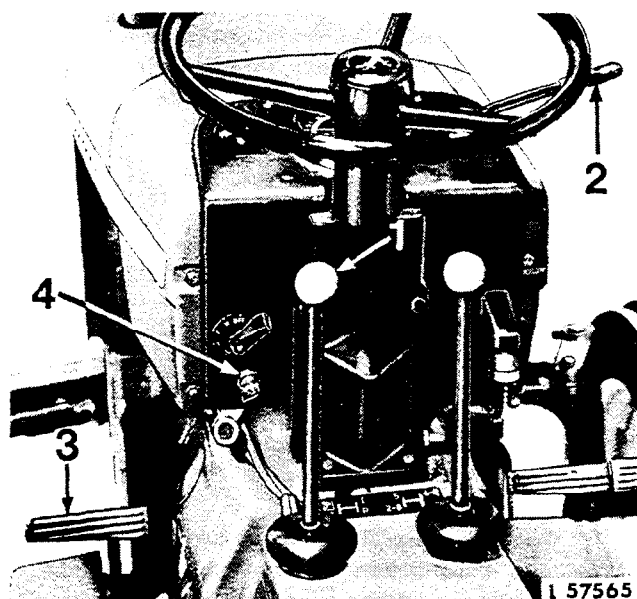

- 1—Range shift lever in neutral or park position.
- 2—Place hand throttle in halfway-open position.
- 3—Depress clutch pedal to decrease drag on engine.
- 4—Turn starter key clockwise to engage starter. As soon as engine starts, release starter key. Do not crank engine for more than 30 seconds at a time. To do so may overheat the starter. Wait a minute or two before engaging starter again.

Release clutch pedal. In cold weather, warm engine and transmission for 5 minutes by operating engine at half throttle.

*NOTE: If engine fails to start, refer to "Trouble Shooting" charts.*

**IMPORTANT:** If you must tow the tractor for starting, do not tow it at a speed greater than normal for the gear in which the tractor is being towed. Tow the tractor for starting only in 6th, 7th, or 8th gear.

## COLD WEATHER STARTING AIDS

To assist in cold weather starting, several aids are available. These aids are effective at low temperatures only when the engine is otherwise operating satisfactorily. They will not correct such deficiencies as low battery charge, crankcase oil of too heavy viscosity, or high electrical resistance, any of which may prevent the engine from starting.

## Auxiliary Batteries

Starting the engine in cold weather can be made easier by connecting an additional 12-volt battery in parallel with the 12-volt battery (or batteries) on the tractor.

**CAUTION:** Gas given off by batteries is explosive. To avoid injury or battery damage, avoid sparks near the batteries.

Use jumper cables to connect the positive (+) terminal of the booster battery to the positive (+) terminal of the tractor batteries and the negative (-) terminal of the booster battery to a good ground on the tractor frame away from the battery. See your JOHN DEERE dealer for booster batteries.

**IMPORTANT:** The batteries on your tractor are **NEGATIVE** grounded only. Reversed polarity in battery or alternator connections will result in damage to electrical system.

## Diesel Starting Fluid Adapter

Your tractor is equipped with a starting fluid adapter. This attachment is used to inject atomized starting fluid into the engine air intake system when starting the engine at temperatures below +32°F (0°C).



To use starting fluid, remove the safety cap and plastic spray button from the can.

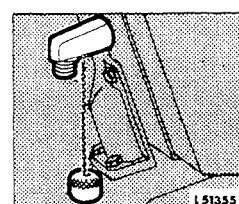

Remove cap from adapter.

## Injecting Diesel Starting Fluid

**IMPORTANT:** To avoid damage, turn engine with starter one or two revolutions before injecting starting fluid.

Inject starting fluid only while engine is turning. Inject starting fluid intermittently, not continuously.

### Injecting Diesel Starting Fluid—Continued



Position can onto adapter and inject fluid by pushing up on can for a short period.

Relax pressure on the can between "shots" of fluid. Stop injecting fluid as soon as the engine starts. If engine begins to die during the first few minutes of operation, inject another "shot" of fluid. When the engine is running smoothly, remove the can from the adapter and replace the safety cap on the can. Be sure to put the cap back on the adapter when not in use. This prevents dust from being drawn into the engine.

Store starting fluid in a cool, dry, and protected area to prevent accidental discharge. Keep the starting fluid away from extreme heat or cold.

**⚠ CAUTION: Ether starting fluid is highly flammable. Do not use near fire, sparks, or flames. Read the cautionary information on the container.**

### Engine Coolant Heater

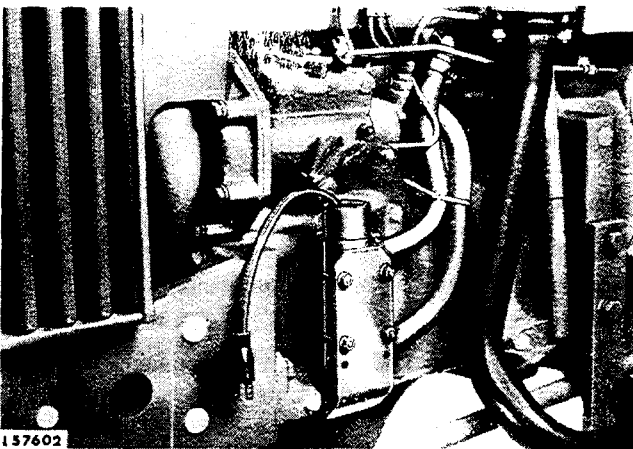

A 1000-watt, 115-volt electrical coolant heater can be installed on the engine. The heater can be plugged into any 115-volt electrical source.

**⚠ CAUTION: To avoid shock or hazardous operation, always use a three wire heavy-duty electrical cord equipped with 3-wire connectors. If a 2- to 3-contact adapter is used at the wall receptacle, always connect the green wire to a good ground.**



**⚠ CAUTION: Before starting the engine, make sure there is plenty of ventilation. Never operate the engine in a closed shed or garage.**

### ENGINE WARM-UP PERIOD

The engine must have attained the correct operating temperature before putting the unit under full load. To warm up the engine, run it for a few minutes with the hand throttle halfway open. Thus excessive wear on piston rings, cylinders and bearings is avoided.

### ENGINE IDLING

Avoid unnecessary engine idling. Prolonged engine idling may cause the engine coolant temperature to drop below its normal range. This in turn causes crankcase oil dilution, due to incomplete fuel combustion, and permits formation of lacquer or gummy deposits on valves, pistons, and piston rings. It also promotes rapid accumulation of engine sludge.

### ENGINE SPEEDS

The engine working speed range is between 1400 and 2400 rpm. Within these limits the engine can be put under full load. Maximum continuous power is obtained at 2400 rpm.

Operate the engine at 2100 rpm to obtain SAE standard PTO speeds.

When using the PTO, set the hand throttle so that the engine speed pointer is even with the green mark on the speed-hour meter.

## STOPPING THE ENGINE

Run the engine at 1400 rpm for a short time before shutting it off completely. This will allow the engine to cool off gradually.

To stop the engine, pull out the shut-off knob (located at bottom - left on dash). Push knob back in as soon as engine has stopped.

**IMPORTANT:** Never attempt to stop the engine by closing the shut-off valve at the fuel tank as this will cause the pump to run dry and damage internal parts.

**CAUTION:** Remove switch key to prevent accidents, tampering, and unauthorized operation.

## PARKING THE TRACTOR

Completely stop the tractor. Move the gear shift lever into any gear position. Then move the range shift lever to park (P) position.

Before dismounting, be sure all equipment is lowered to the ground and the light switch and other accessory switches are off.

## TOWING THE TRACTOR

When towing the tractor, move both the gear and range shift levers to the neutral position. Thus you will avoid any unnecessary transmission wear.

**CAUTION:** Never tow the tractor at a speed greater than 15 miles per hour (25 km/h).

## BREAK-IN PERIOD

After the first 4 hours and 8 hours of operation re-tighten all wheel retainers and front axle bolts. Check tightness of retainers and axle bolts frequently during the first 100 hours of operation.

Thereafter check tightness of bolts and screws periodically.

Recommended Torques are as follows:

### Rear Wheels

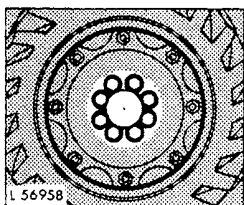

Wheel disk-to-axle flange 130 ft-lbs (18 mkg) torque.

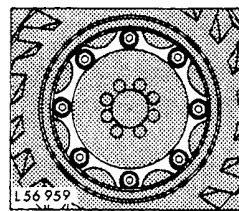

Rim-to-wheel disk 145 ft-lbs (20 mkg) torque.

### Front Wheels

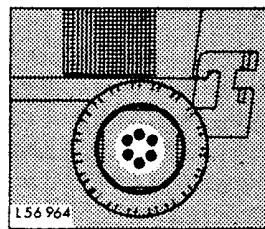

Wheel-to-axle flange 87 ft-lbs (12 mkg) torque.

### Front Axle

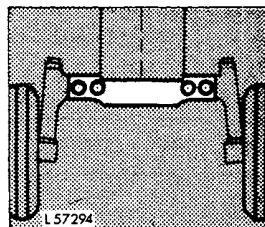

Axle bolts 300 ft-lbs (41.5 mkg) torque.

The tractor should be operated under normal load during the first 20 hours of operation.

**IMPORTANT:** Avoid light loads or excessive engine idling.

Ideal conditions for breaking in a tractor engine would require operating the tractor at full engine speed under 75% of full load. Under such operating conditions an engine would be broken in after approximately the first 100 hours.

In most cases, however, it is practically impossible to operate the tractor under these conditions during the first hours. This is the reason why, in many cases, the duration of the break-in period is considerably longer than 100 hours.

Under very light load conditions some engines may never break in which results in glazed cylinder liners.

During the break-in period a higher-than-usual oil consumption should be considered as normal.

Check periodically to be sure that an adequate supply of oil is maintained in the crankcase.

At the end of the first 50 hours of operation, replace the transmission system oil filter.

**BREAK-IN PERIOD—Continued**

At the end of the first 100 hours of operation, drain and refill crankcase and replace filter element.

We recommend that you ask your JOHN DEERE dealer to carry out a general inspection of the tractor before the first 100 operating hours are completed.

**SELECTING TRAVEL SPEEDS**

The tractor has eight forward gears and four reverse gears. These gears, together with the engine speeds that may be selected, allow the operator to balance load and speed for maximum economy, and give him flexibility to meet varying work conditions. For example, for a given travel speed the operator may choose to work in a low gear at a high engine speed or in a higher gear at a lower engine speed.

Gears should be selected so as to avoid a permanent overloading of the engine.

**HIGH SPEED DRIVING**

A higher gear can be used when traveling on good, straight roads.

On bad, curvy roads or when working on slopes, it is necessary to shift to a lower gear and to reduce speed.



**CAUTION: Fast driving causes many accidents. Couple the brake pedals together and always drive at a safe speed.**

**TRAVEL SPEEDS AT 2400 ENGINE RPM**

Tire Sizes	13.6 - 28		14.9 - 28		16.9 - 24		21.5L - 16.1		16.5L - 16.1		18.4 - 16.1	
	mph	km/h	mph	km/h	mph	km/h	mph	km/h	mph	km/h	mph	km/h
Gear 1	1.4	2.2	1.4	2.3	1.3	2.2	1.1	1.8	1.0	1.7	1.1	1.8
Gear 2	2.0	3.1	2.0	3.2	1.9	3.1	1.6	2.6	1.5	2.4	1.6	2.6
Gear 3	2.9	4.7	3.0	4.9	2.8	4.6	2.4	3.8	2.2	3.5	2.4	3.9
Gear 4	4.1	6.5	4.2	6.8	4.0	6.4	3.3	5.3	3.1	4.9	3.4	5.4
Gear 5	5.4	8.6	5.6	9.0	5.3	8.5	4.4	7.0	4.0	6.5	4.4	7.1
Gear 6	7.7	12.3	8.0	12.9	7.5	12.1	6.2	10.0	5.8	9.3	6.3	10.2
Gear 7	11.4	18.3	11.8	19.1	11.2	18.0	9.2	14.9	8.6	13.8	9.4	15.2
Gear 8	15.9	25.6	16.6	26.7	15.6	25.2	12.9	20.8	12.0	19.3	13.2	21.2
R 1	1.6	2.6	1.7	2.7	1.6	2.5	1.3	2.1	1.2	1.9	1.3	2.1
R 2	2.3	3.7	2.4	3.8	2.2	3.6	1.8	3.0	1.7	2.8	1.9	3.0
R 3	3.4	5.4	3.5	5.6	3.3	5.3	2.7	4.4	2.5	4.1	2.8	4.5
R 4	4.7	7.6	4.9	7.9	4.6	7.5	3.8	6.2	3.5	5.7	3.9	6.3

**TRAVEL SPEEDS AT 2100 ENGINE RPM  
(Engine Speed For PTO Operation)**

Tire Sizes	13.6 - 28		14.9 - 28		16.9 - 24		21.5L - 16.1		16.5L - 16.1		18.4 - 16.1	
	Gear	mph	km/h	mph	km/h	mph	km/h	mph	km/h	mph	km/h	mph
1	1.2	1.9	1.2	2.0	1.1	1.9	1.0	1.6	0.9	1.5	1.0	1.6
2	1.8	2.7	1.8	2.8	1.7	2.7	1.4	2.3	1.3	2.1	1.4	2.3
3	2.5	4.1	2.6	4.3	2.5	4.0	2.1	3.3	1.9	3.1	2.1	3.4
4	3.6	5.7	3.7	6.0	3.5	5.6	2.9	4.6	2.7	4.3	3.0	4.7
5	4.7	7.5	4.9	7.9	4.6	7.4	3.9	6.1	3.5	5.7	3.9	6.2
6	6.7	10.8	7.0	11.4	6.6	10.6	5.4	8.7	5.1	8.1	5.5	8.9
7	10.0	16.0	10.3	16.7	9.8	15.7	8.0	13.0	7.5	12.1	8.2	13.3
8	13.9	22.4	14.5	23.4	13.6	22.1	11.4	18.2	10.1	16.9	11.5	18.6
R 1	1.4	2.3	1.5	2.4	1.4	2.2	1.1	1.8	1.1	1.7	1.1	1.8
R 2	2.0	3.2	2.1	3.3	1.9	3.2	1.6	2.6	1.5	2.5	1.7	2.6
R 3	3.0	4.7	3.1	4.9	2.9	4.6	2.4	3.9	2.2	3.6	2.5	3.9
R 4	4.1	6.6	4.3	6.9	4.0	6.6	3.3	5.4	3.1	5.0	3.4	5.5

**SHIFTING GEARS**

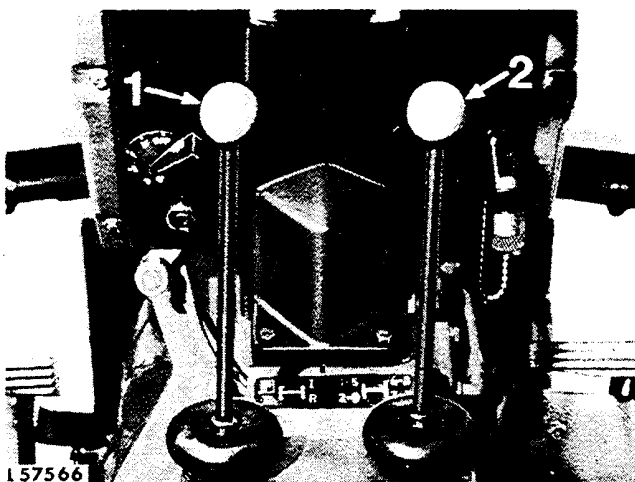

1—Range shift lever (left-hand lever)  
2—Gear shift lever (right-hand lever)

Gear shifting is controlled by a range shift lever and a gear shift lever.

With the range shift lever a low or high range of gears can be engaged.

Shift Pattern



Range Shift Lever Positions

Gear Shift Lever Positions

- 1—Low range
- II—High range
- P—Park position
- R—Reverse range

Use range shift lever to engage park (P) position.

The gear shift lever can be used to select 1st, 2nd, 3rd, and 4th gears when the range shift lever is in low range position; it can be used to select 5th, 6th, 7th, and 8th gears when the range shift lever is in high range position. When the range shift lever is in reverse range, reverse gears comparable to 1st, 2nd, 3rd, and 4th can be obtained.

### Shifting from Neutral

1. Depress clutch pedal.
2. Move range and gear shift levers in the position required.
3. Gradually release clutch pedal, however, do not allow clutch to slip longer than necessary to take up load smoothly.

To shift "on the go" from lower to higher gear, increase engine speed, depress clutch, decrease engine speed, engage higher gear, release clutch slowly and increase engine speed.

To shift "on the go" from higher to lower gear, decrease engine speed, depress clutch pedal, place gear shift lever in neutral, release clutch momentarily, increase engine speed, declutch, and select lower gear. Release clutch slowly.

Avoid gear clash when shifting "on the go".

### Shifting to Another Range

To shift to another range, fully stop the unit, disengage the clutch and then change gear range as required.

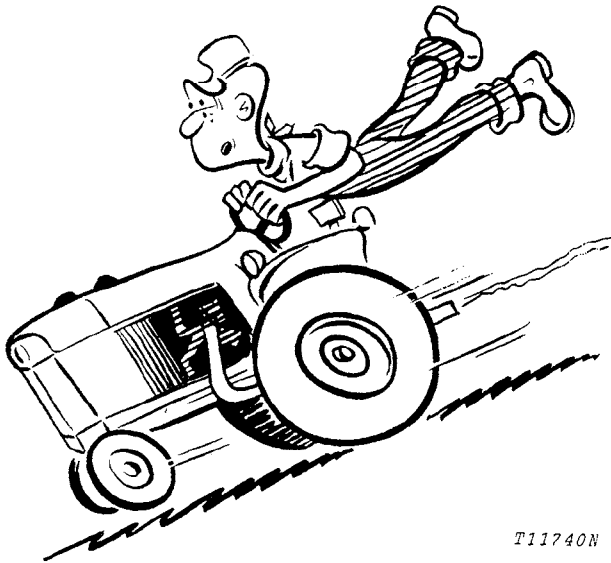

**CAUTION:** Do not allow tractor to coast downhill with clutch disengaged and transmission in gear. This could result in loss of control, in over-speeding, and damage to the clutch.

### DIFFERENTIAL LOCK

With differential lock engaged, power is transferred equally to both rear wheels. This prevents the usual loss of traction when one wheel is slipping.

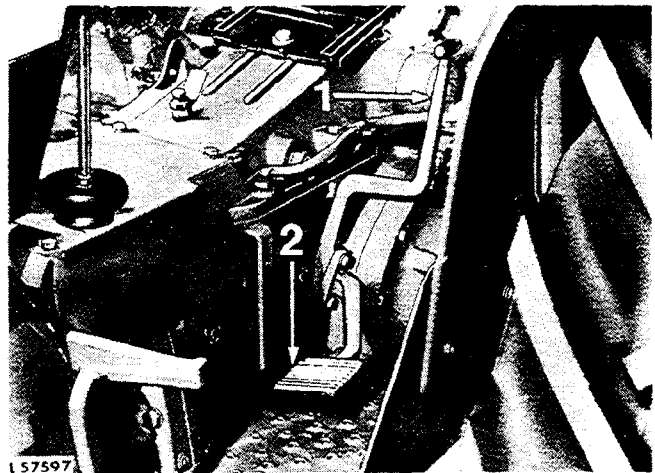

1—Hand lever  
2—Pedal

To engage the differential lock, push out on the lever (or down on the pedal). Unequal traction will keep the lock engaged. You may have to hold the lever or pedal engaged if unequal traction is not continuous.

**CAUTION:** Do not operate the tractor at high speeds or attempt to turn the tractor with the differential lock engaged.

### STEERING

The tractor may be equipped with manual or power steering. Power steering makes steering and control of the tractor easier for the operator. In case of pressure failure, the tractor can be steered manually.

### HYDRAULIC FOOT BRAKES

**CAUTION:** Brake pedals should be coupled together by means of pedal coupler when traveling at high speeds or when driving on public roads.

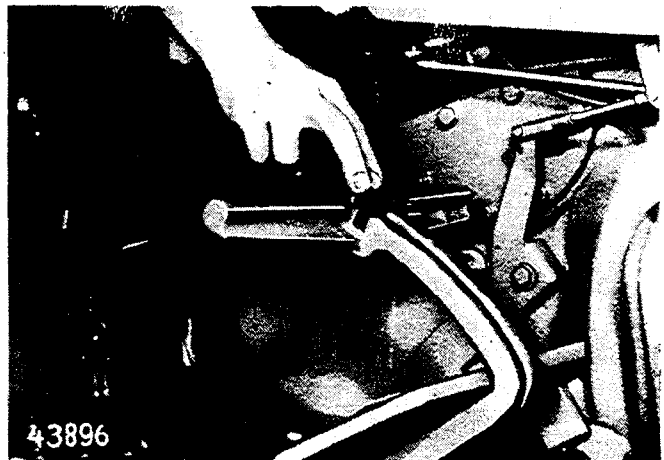

Coupling brake pedals together

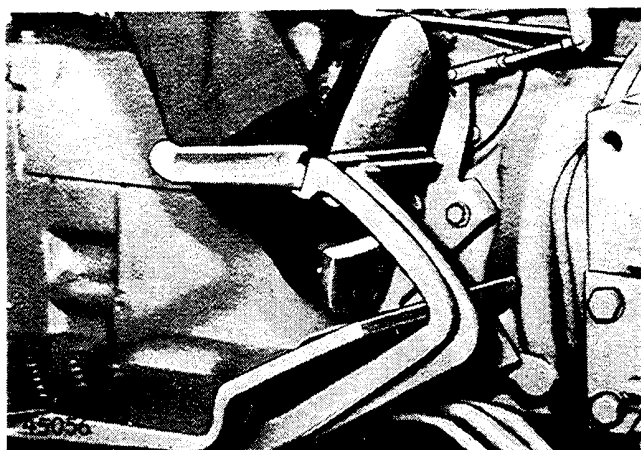

Using foot brake to make a sharp left-hand turn

When turning the tractor, press down on a single brake pedal. Use the left pedal to turn left and the right pedal to turn right. When negotiating sharp turns, press brake pedal down more sharply as the steering wheel is being turned.

Use brake for steering purposes at low speed only.

When stopping the tractor, press down on both brake pedals.

**CAUTION:** Your safety may depend on your tractor brakes. If they become defective, have them repaired right away.

### TOWED LOADS

**CAUTION:** Towed loads that weigh more than twice the weight of the tractor should have brakes. If not, reduce speed and avoid inclines.

### LIGHTS

#### Light Switch

Switch positions are marked on the light switch plate. Turn switch clockwise until position required is in uppermost (vertical) position.

Light switch positions are as follows:

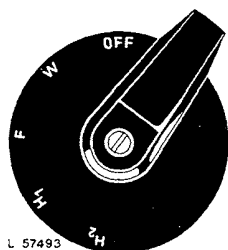

L 57493

- Off
- W - Warning lamps
- F - Bright headlights and rear work light
- H1 - Bright headlights, tail light, and warning lamps
- H2 - Dim headlights, tail light, and warning lamps

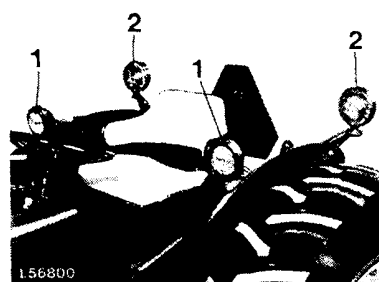

1—Headlights 2—Tractor warning lamps, front view

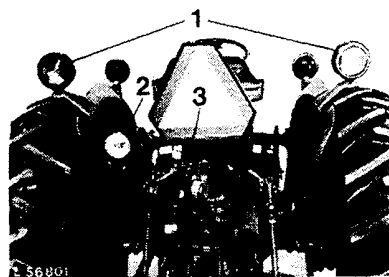

1—Tractor warning lamps, rear view 3—Electrical outlet socket  
2—Rear work light and tail light

### Turn-Signal Switch (If Equipped)

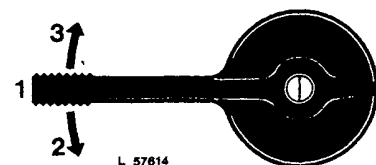

L 57614

- 1—Off
- 2—Turn signal light, left
- 3—Turn signal light, right

### HIGHWAY DRIVING

When transporting (or driving) the tractor on a road or highway at night or during the day, use accessory lights and devices for adequate warning to the operators of other vehicles. In this regard, check local governmental regulations. Various safety lights and devices are available from your John Deere dealer.

When driving on the highway, use light switch position H1 or H2. Be sure the lights are adjusted so they will not blind the driver of an oncoming vehicle.

Always dim (H2 position) the tractor headlights when meeting a vehicle at night.

## OPERATOR'S SEAT

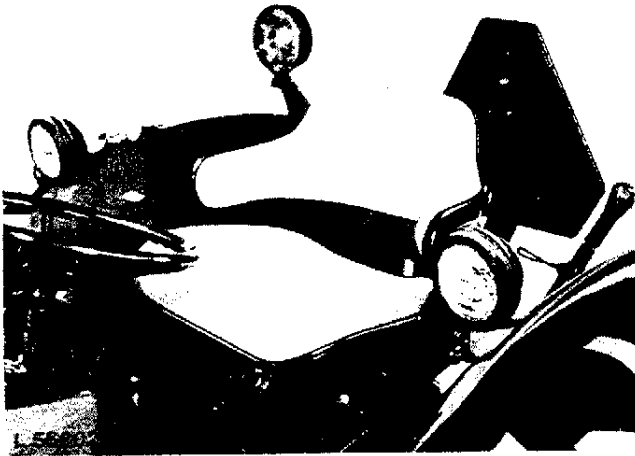

The deluxe seat is adjustable for the operator's height and weight and folds back for standing.

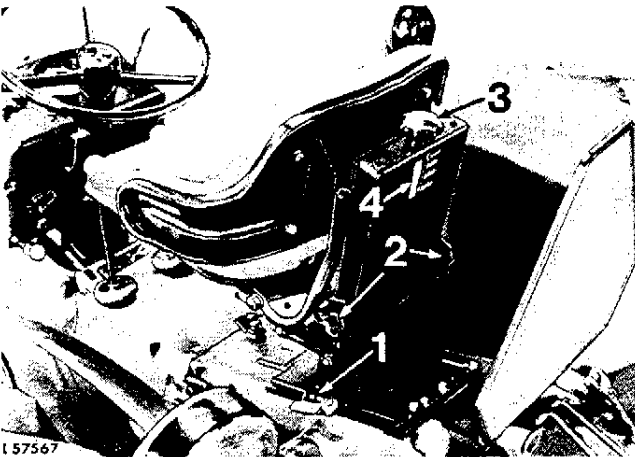

1—Raise catch and adjust horizontally.

2—Loosen handwheels on both sides and adjust seat to desired height. Retighten both handwheels securely.

3—Handwheel for adjusting according to operator's weight.

4—Weight adjustment pattern.

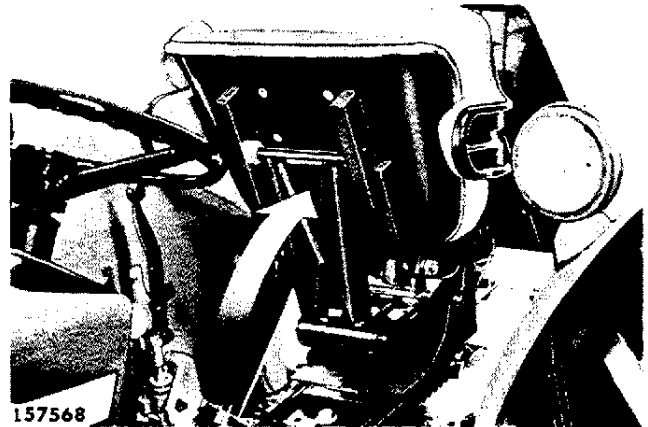

The operator's seat can be folded back against the backrest to drive tractor while standing.

## ROLL-GARD AND SEAT BELT

A protective Roll-Gard with seat belt is available for your tractor. A canopy that fits on top of the Roll-Gard is also available.

When installing a Roll-Gard, tighten the cap screws sufficiently to hold the mounting plate flat against the axle housing. Then in a diagonal sequence, tighten to 50 ft-lbs (7 mkg) torque. Retighten the cap screws in the same sequence to 300 ft-lbs (41.5 mkg) torque. After a few hours of service, retighten the cap screws and keep them tight.



**CAUTION:** Under almost all operating conditions:

1. Use of the seat belt with the optional John Deere Roll-Gard is recommended.
2. Use of a seat belt without roll-over protective equipment is not recommended.



**Suggest:**

**If the above button click is invalid.**

**Please download this document**

**first, and then click the above link**

**to download the complete manual.**

**Thank you so much for reading**

**CAUTION:** A tractor roll-over may place a severe stress on the Roll-Gard structure. Therefore, re-use of the Roll-Gard is not recommended if its upright beams, cross-bar, or attaching parts have been bent, buckled, or stretched.

**CAUTION:** If your tractor has a Roll-Gard, use AR61868 Non-Spill battery vent caps to prevent injury from spilled battery acid should the tractor overturn and be supported upside-down by the Roll-Gard.

**STEP PLATE**

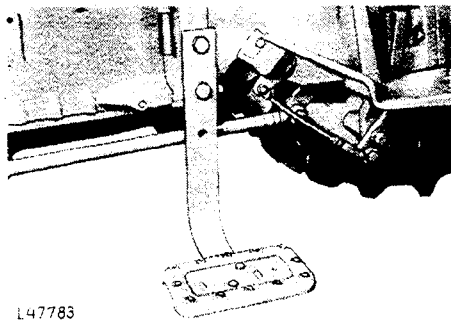

A step plate is available as special equipment to facilitate getting up to the operator's seat. It is installed at the side of the tractor.

**WHEEL TREADS**

**Adjustable Front Axle**

Two types of front axles are available. The type of front axle installed is dependent upon the size of the rear wheels.

Wheel treads available are shown in the following chart:

Front Tire Size	Front Wheel Tread*		Max. with Wheels Reversed
	Min.	Max.	
6.00 - 16	49.61 in.	74.17 in.	79.45 in.
6.50 - 16	(1260 mm)	(1884 mm)	(2018 mm)
27/9.5-15* *	50.24 in.	74.81 in.	.....
	(1276 mm)	(1900 mm)	.....
27/9.5-15* * *	46.24 in.	63.24 in.	.....
	(1175 mm)	(1606 mm)	.....
23/10.5-12	49.32	66.32 in.	.....
	(1253 mm)	(1685 mm)	.....

\* Front axle adjustable in increments of 1.89 in. (48 mm)

\* \* Used with 16.9-24 rear tires (medium knee).

\* \* \* Used with 18.4-16.1 or 21.5L-16.1 rear tires (short knee).

**IMPORTANT:** To avoid excessive stress on axle bolts, do not separate axle halves beyond the limits shown.

Bolt spacing should be 4 inches (102 mm) in maximum tread width and 6 inches (153 mm) in all other tread widths.

**Adjusting Front Wheel Tread**

Jack up front end of tractor.

Do not place jack under engine oil pan.

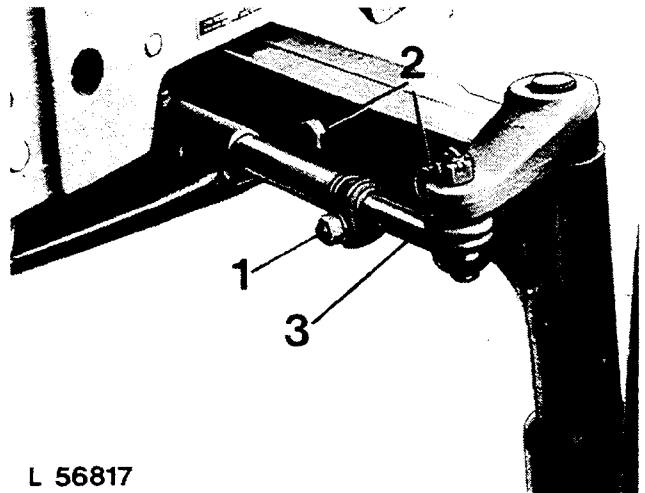

**L 56817**

1—Remove tie rod clamp bolts.

2—Remove axle bolts and reposition axle ends to the desired front wheel tread. Insert axle bolts and tighten nuts to 300 ft-lbs (41.5 mkg) torque.

3—The tie rods have grooves to simplify adjustment. Adjust the same distance as the axles. Insert and tighten tie rod clamp bolts to 85 ft-lbs (11.7 mkg) torque.

Check to see that front wheels turn equally to right and left. Check toe-in and adjust, if necessary.

**Checking Front Wheel Toe-In**

Check front wheel toe-in periodically with tractor on level ground and front wheels in straight-ahead position.

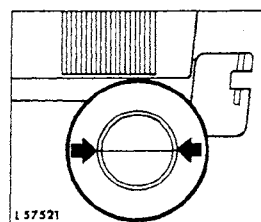

Front and rear of front wheels at hub height.

**<https://www.ebooklibonline.com>**

Hello dear friend!

Thank you very much for reading.

Enter the link into your browser.

The full manual is available for immediate download.

**<https://www.ebooklibonline.com>**