

JOHN DEERE
WORLDWIDE COMMERCIAL & CONSUMER
EQUIPMENT DIVISION

Aercore™ Aerator
800

OMTCU21565 E0

OPERATOR'S MANUAL



JOHN DEERE

⚠ WARNING: The Engine Exhaust from this product contains chemicals known to the State of California to cause cancer, birth defects or other reproductive harm.

California Proposition 65 Warning

North American Version
Litho in U.S.A.

INTRODUCTION

Thank You for Purchasing a John Deere Product

We appreciate having you as a customer and wish you many years of safe and satisfied use of your machine.

Using Your Operator's Manual

This manual is an important part of your machine and should remain with the machine when you sell it.

Reading your operator's manual will help you and others avoid personal injury or damage to the machine. Information given in this manual will provide the operator with the safest and most effective use of the machine. Knowing how to operate this machine safely and correctly will allow you to train others who may operate this machine.

If you have an attachment, use the safety and operating information in the attachment operator's manual along with the machine operator's manual to operate the attachment safely and correctly.

This manual and safety signs on your machine may also be available in other languages (see your authorized dealer to order).

Sections in your operator's manual are placed in a specific order to help you understand all the safety messages and learn the controls so you can operate this machine safely. You can also use this manual to answer any specific operating or servicing questions. A convenient index located at the end of this book will help you to find needed information quickly.

The machine shown in this manual may differ slightly from your machine, but will be similar enough to help you understand our instructions.

RIGHT-HAND and LEFT-HAND sides are determined by facing in the direction the machine will travel when going forward. When you see a broken line (-----), the item referred to is hidden from view.

Before delivering this machine, your dealer performed a predelivery inspection to ensure best performance.

Special Messages

Your manual contains special messages to bring attention to potential safety concerns, machine damage as well as helpful operating and servicing information. Please read all the information carefully to avoid injury and machine damage.



CAUTION: Avoid injury! This symbol and text highlight potential hazards or death to the operator or bystanders that may occur if the hazards or procedures are ignored.

IMPORTANT: Avoid damage! This text is used to tell the operator of actions or conditions that might result in damage to the machine.

NOTE: General information is given throughout the manual that may help the operator in the operation or service of the machine.

PRODUCT IDENTIFICATION

Record Identification Numbers

Aercore® Aerator 800 PIN (060001-)

If you need to contact an Authorized Service Center for information on servicing, always provide the product model and serial number.

You will need to locate the model and serial number for the machine and for the engine of your machine and record the information in the spaces provided below.

DATE OF PURCHASE:

DEALER NAME:

DEALER PHONE:

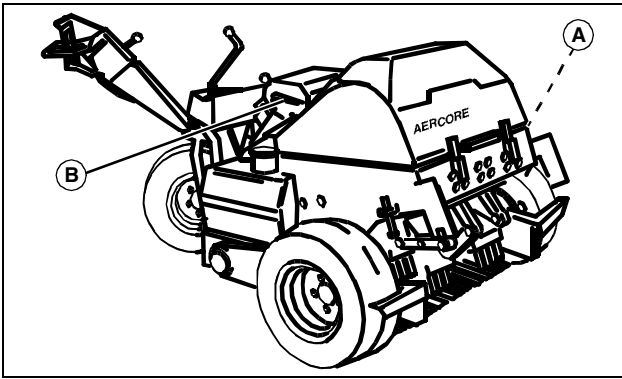

MIF

PRODUCT IDENTIFICATION NUMBER (A):

ENGINE SERIAL NUMBER (B):

<https://www.ebooklibonline.com>

Hello dear friend!

Thank you very much for reading.

Enter the link into your browser.

The full manual is available for immediate download.

<https://www.ebooklibonline.com>

TABLE OF CONTENTS

Safety Labels	1
Safety	4
Operating - Machine	8
Replacement Parts	24
Service Intervals	25
Service Engine	26
Service Electrical	30
Service	34
Service Miscellaneous	49
Troubleshooting	52
Storage	55
Specifications	57
Warranty	59
Index	61

Original Instruction

All information, illustrations and specifications in this manual are based on the latest information at the time of publication. The right is reserved to make changes at any time without notice.

COPYRIGHT© 2010

Deere & Co.

John Deere Worldwide Commercial and Consumer Equipment Division

All rights reserved

Previous Editions

COPYRIGHT© 2002, 2005

OMTCU21565 E0 -

SAFETY LABELS

Safety Label Location

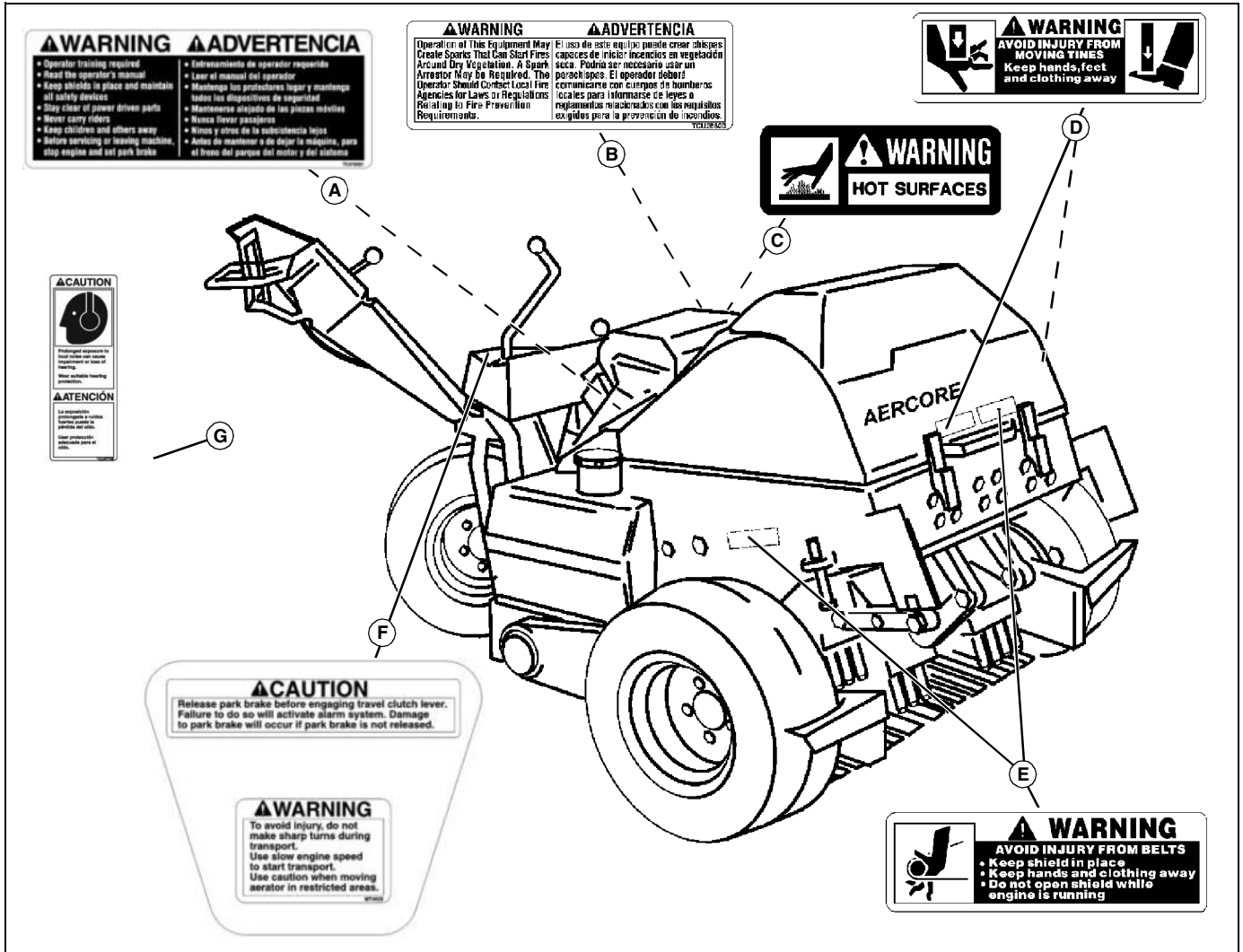

MX44132a

- A - WARNING TCU19301
- B - WARNING TCU26800
- C - WARNING M118611
- D - CAUTION MT3044
- E - WARNING MT3082
- F - CAUTION/WARNING MT4925
- G - CAUTION TCU27738

On your machine safety labels, the words DANGER, WARNING, and CAUTION are used with this safety-alert symbol. DANGER identifies the most serious hazards.

The operator's manual also explains any potential safety hazards whenever necessary in special safety messages that are identified with the word, CAUTION, and the safety-alert symbol.

There can be additional safety information contained on parts and components sourced from suppliers that is not reproduced in this operator's manual.



Understanding The Machine Safety Labels

The machine safety labels shown in this section are placed in important areas on your machine to draw attention to potential safety hazards.

SAFETY LABELS

WARNING TCU19301



TCU19301

- Operator training required
- Read the operator's manual
- Stay clear of power driven parts
- Never carry riders
- Keep children and others away
- Before servicing or leaving machine, stop engine and set park brake

WARNING TCU26800

SPARK ARRESTOR



TCU26800

Operation of This Equipment May Create Sparks That Can Start Fires Around Dry Vegetation. A Spark Arrestor May Be Required. The Operator Should Contact Local Fire Agencies for Laws or Regulations Relating to Fire Prevention Requirements.

WARNING M118611

HOT SURFACES



M118611

- Hot Surfaces

WARNING MT3044

AVOID INJURY FROM MOVING TINES



MT3044

- Keep hands, feet and clothing away

WARNING MT3082

AVOID INJURY FROM BELTS



MT3082

- Keep shield in place
- Keep hands and clothing away
- Do not open shield while engine is running

SAFETY LABELS

WARNING MT4925

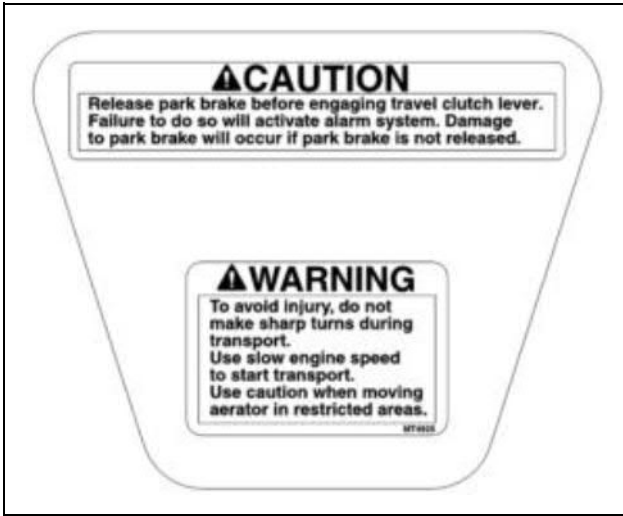

MT4925d

- Release park brake before engaging travel clutch lever. Failure to do so will activate alarm system. Damage to park brake will occur if park brake is not released.
- To avoid injury, do not make sharp turns during transport. Use slow engine speed to start transport. Use caution when moving aerator in restricted areas.

CAUTION TCU27738



TCU27738

- Prolonged exposure to loud noise can cause impairment or loss of hearing.
- Wear suitable hearing protection.

Emission Control System Certification Label

NOTE: *Tampering with emission controls and*

components by unauthorized personnel may result in severe fines or penalties. Emission controls and components can only be adjusted by EPA and/or CARB authorized service centers. Contact your John Deere Commercial and Consumer Equipment Retailer concerning emission controls and component questions.

The presence of an emissions label signifies that the engine has been certified with the United States Environmental Protection Agency (EPA) and/or California Air Resources Board (CARB).

The emissions warranty applies only to those engines marketed by John Deere that have been certified by the EPA and/or CARB; and used in the United States and Canada in off-road mobile equipment.

Emission Compliance Period

If your engine has the emission compliance category listed on the emission control system certification or air index label, this indicates the number of operating hours for which the engine has been certified to meet EPA and/or CARB emission requirements. The following table provides the engine compliance period in hours associated with the category found on the certification label.

Agency	Category	Hours
EPA	C	125
EPA	B	250
EPA	A	500
CARB	Moderate	125
CARB	Intermediate	250
CARB	Extended	500

Canadian Electromagnetic Compatibility (EMC) Compliance

This spark ignition system complies with Canadian ICES-002.

Certification

Your product has been certified for compliance with American National Standards Institute B-71.4, Safety Specifications for Commercial Turf care Equipment.

SAFETY

Operator Training Required

- Read the operator's manual and other training material. If the operator or mechanic cannot read English, it is the owner's responsibility to explain this material to them. This publication is available in other languages.
- Become familiar with the safe operation of the equipment, operator controls, and safety signs.
- All operators and mechanics should be trained. The owner of the machine is responsible for training the users.
- Never let children or untrained people operate or service the equipment. Local regulations may restrict the age of the operator.
- The owner/user can prevent and is responsible for accidents or injuries occurring to themselves, other people, or property.
- Operate the machine in an open, unobstructed area under the direction of an experienced operator.

Preparation

- Evaluate the terrain to determine what accessories and attachments are needed to properly and safely perform the job. Only use accessories and attachments approved by the manufacturer.
- Wear appropriate clothing including hard hat, safety glasses and hearing protection. Long hair, loose clothing or jewelry may get tangled in moving parts.
- Inspect the area where the equipment is to be used and remove all objects such as rocks, toys and wire which can be thrown by the machine.
- Use extra care when handling gasoline and other fuels. They are flammable and vapors are explosive.
 - a. Use only an approved container.
 - b. Never remove gas cap or add fuel when engine is running. Do not smoke.
 - c. Never refuel or drain the machine indoors.
- Check that the operator's presence controls, safety switches and shields are attached and functioning properly. Do not operate unless they are functioning properly.

Operation

- Never run an engine in an enclosed area where dangerous carbon monoxide fumes can collect.
- Only operate in good light, keeping away from holes and hidden hazards.
- Be sure all drives are in neutral and parking brake is

engaged before starting engine. Only start engine from the operator's position.

- Be sure of your footing while using pedestrian-controlled equipment, especially when backing up. Walk, don't run. Never operate on wet grass. Reduced footing could cause slipping.
- Slow down and use extra care on hillsides. Be sure to travel in the recommended direction on hillsides. Turf conditions can affect the machine's stability. Use caution while operating near drop-offs.
- Slow down and use caution when making turns and when changing directions on slopes.
- Never operate with guards not securely in place. Be sure all interlocks are attached, adjusted properly, and functioning properly.
- Do not change the engine governor setting or overspeed the engine. Operating the engine at excessive speed can increase the hazard of personal injury.
- Stop equipment and inspect the tines after striking objects or if an abnormal vibration occurs. Make necessary repairs before resuming operations. Keep machine and attachments properly maintained and in good working order.
- Keep hands and feet away from the tines.
- Look down and behind before backing up to be sure of a clear path.
- Never carry passengers and keep pets and bystanders away.
- Do not operate machine if you are under the influence of drugs or alcohol.
- Use care when loading or unloading the machine into or off of a trailer or truck.
- Use care when approaching blind corners, shrubs, trees, or other objects that may obscure vision.
- Only allow responsible adults, who are familiar with the instructions to operate the machine.
- Inspect machine before you operate. Be sure hardware is tight. Repair or replace damaged, badly worn, or missing parts. Replace faulty mufflers or silencers. Be sure guards and shields are in good condition and fastened in place. Make any necessary adjustments before you operate.
- Do not make sharp turns during transport.
- Use caution when moving aerator in restricted areas.
- Check brake action before you operate. Adjust or service brakes as necessary.
- Do not leave machine unattended when it is running.
- Raise the aeration head and stop tining action before crossing surfaces other than grass.

SAFETY

- Use only accessories and attachments approved by the manufacturer of the machine. Keep safety labels visible when installing accessories and attachments.
- Check before each use that operator presence controls are functioning correctly. Test safety systems. Do not operate unless they are functioning correctly.
- Do not wear radio or music headphones. Safe service and operation require your full attention.
- Reduce the throttle setting during engine run-out and, if the engine is provided with a fuel shut-off valve, turn the fuel off at the conclusion of mowing.
- When machine is left unattended, stored, or parked, lower the aeration head unless a positive mechanical lock is used.

Parking Safely

1. Park machine on a level surface.
2. Block machine safely off the ground using transport stops.
3. Lock the park brake.
4. Stop the engine and remove the key.

Be Familiar with Work Area

- Identify locations of buried irrigation and electrical cables.
- Identify locations of sprinkler heads, fairway markers and other obstacles.
- Identify areas on greens where there is little or no room for turning aerator at end of a pass.
- Have a plan for aerating the green before beginning.

Avoid Tipping

- Do not operate where machine could slip or tip.
- Stay alert for holes and other hidden hazards in the terrain.
- Operate up and down a hill - not across. Be careful when you change direction on a slope.
- Keep away from drop-offs.
- Slow down before you make a sharp turn or operate on a slope.

Keep Riders Off

- Riders on the machine or attachment may be struck by foreign objects or thrown off the machine causing serious injury.
- Riders obstruct the operator's view resulting in the machine being operated in an unsafe manner.

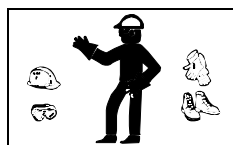

Wear Appropriate Clothing

- Always wear safety goggles, or safety glasses with side shields when operating the machine.
- Wear close fitting clothing and safety equipment appropriate for the job.
- While mowing, always wear substantial footwear and long trousers. Do not operate the equipment when barefoot or wearing open sandals.
- Wear a suitable protective device such as earplugs. Loud noise can cause impairment or loss of hearing.



Avoid Injury from Moving Parts

- Keep hands, feet, clothing and other objects away from moving parts.
- Do not attempt to remove any obstruction from tine area while aerator is in motion.
- Keep hands and feet away from the tine area while the engine is running. When the engine is running, tining action will begin as soon as the aeration head begins to lower.

Maintenance and Storage

- Never operate machine in a closed area where dangerous carbon monoxide fumes can collect.
- Disengage drives, lower implement, lock parking brake, stop engine and remove key or disconnect spark plug (for gas engines). Wait for all movement to stop before adjusting, cleaning or repairing.
- Let engine cool before storing and do not store near flame.
- Shut off fuel while storing or transporting. Do not store fuel near flames or drain indoors.
- Park machine on level ground. Never allow untrained personnel to service machine. Understand service procedure before doing work.
- Use jack stands or lock service latches to support

SAFETY

components when required. Securely support any machine elements that must be raised for service work.

- Before servicing machine or attachment, carefully release pressure from any components with stored energy, such as hydraulic components or springs.
- Release hydraulic pressure by lowering attachment or cutting units to the ground or to a mechanical stop and move hydraulic control levers back and forth.
- Disconnect battery or remove spark plug (for gas engines) before making any repairs. Disconnect the negative terminal first and the positive last. Reconnect positive first and negative last.
- Keep hands, feet, clothing, jewelry and long hair away from moving parts. If possible, do not make adjustments with the engine running.
- Charge batteries in an open well ventilated area, away from spark and flames. Unplug charger before connecting or disconnecting from battery. Wear protective clothing and use insulated tools.
- Keep all parts in good working condition and all hardware tightened. Replace all worn or damaged decals.
- Understand service procedure before doing work. Keep area clean and dry.
- Never lubricate, service, or adjust machine while it is moving. Keep safety devices in place and in working condition. Keep hardware tight.
- Do not open shield while engine is running.
- Never run engine unless park brake is locked.
- To prevent fires, remove any buildup of grease, oil, or debris from the machine, especially the engine compartment.
- Do not modify machine or safety devices. Unauthorized modifications may impair its function and safety.

Prevent Fires

- Machine fires and structure fires can occur if a machine is stored before allowing it to cool, if debris is not removed from critical areas of the machine, or if machine is stored near combustible materials.
- Remove grass and debris from engine compartment and muffler area, before and after operating machine.
- Always shut off fuel when storing or transporting machine, if the machine has a fuel shutoff.
- Do not store machine near an open flame or source of ignition, such as a water heater or furnace.
- Check fuel lines, tank, cap, and fittings frequently for cracks or leaks. Replace if necessary.



Tire Safety

Explosive separation of a tire and rim parts can cause serious injury or death:

- Do not attempt to mount a tire without the proper equipment and experience to perform the job.
- Always maintain the correct tire pressure. Do not inflate the tires above the recommended pressure. Never weld or heat a wheel and tire assembly. The heat can cause an increase in air pressure resulting in a tire explosion. Welding can structurally weaken or deform the wheel.
- When inflating tires, use a clip-on chuck and extension hose long enough to allow you to stand to one side and NOT in front of or over the tire assembly.
- Check tires for low pressure, cuts, bubbles, damaged rims or missing lug bolts and nuts.

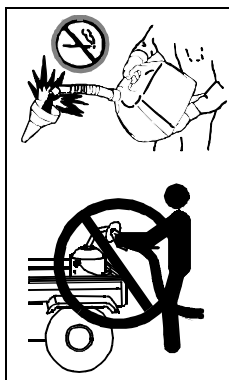

Handling Fuel Safely

To avoid personal injury or property damage, use extreme care in handling fuel. Fuel is extremely flammable and fuel vapors are explosive:

- Extinguish all cigarettes, cigars, pipes, and other sources of ignition.
- Use only approved non-metal, portable fuel containers. If using a funnel, make sure it is plastic and has no screen or filter.
- Never remove the fuel tank cap or add fuel with the engine running. Allow engine to cool before refueling.
- Never add fuel to or drain fuel from the machine indoors. Move machine outdoors and provide adequate ventilation.
- Clean up spilled fuel immediately. If fuel is spilled on clothing, change clothing immediately. If fuel is spilled near machine, do not attempt to start the engine but move the machine away from the area of spillage. Avoid creating any source of ignition until fuel vapors have dissipated.
- Never store the machine or fuel container where there is an open flame, spark, or pilot light such as on a water heater or other appliance.
- Prevent fire and explosion caused by static electric discharge. Static electric discharge can ignite fuel vapors in an ungrounded fuel container.
- Never fill containers inside a vehicle or on a truck or trailer bed with a plastic liner. Always place containers on the ground away from your vehicle before fueling.

SAFETY

- Remove fuel-powered equipment from the truck or trailer and refuel it on the ground. If this is not possible, then refuel such equipment with a portable container, rather than from a fuel dispenser nozzle.
- Keep the nozzle in contact with the rim of the fuel tank or container opening at all times until the fueling is complete. Do not use a nozzle lock-open device.
- Never overfill fuel tank. Replace fuel tank cap and tighten securely.
- Replace all fuel container caps securely after use.
- For gasoline engines, do not use gas with methanol. Methanol is harmful to your health and to the environment.

Handling Waste Product and Chemicals

Waste products, such as, used oil, fuel, coolant, brake fluid, and batteries, can harm the environment and people:

- Do not use beverage containers for waste fluids - someone may drink from them.
- See your local Recycling Center or authorized dealer to learn how to recycle or get rid of waste products.
- See your local Recycling Center or authorized dealer to learn how to put your machine out of service at the end of the machine's service life.

OPERATING - MACHINE

Daily Operating Checklist

- Check gas and oil levels.
- Check for correct tire pressure.
- Check brake action.
- Check belt tension.
- Check for damaged turf guards.
- Check for loose or broken tines.
- Check for loose or missing hardware.
- Check for bent or damaged aerating links.

Avoid Damage to Plastic and Painted Surfaces

- Do not wipe plastic parts unless rinsed first. Using a dry cloth may cause scratches.
- Insect repellent spray may damage plastic and painted surfaces. Do not spray insect repellent near machine.
- Be careful not to spill fuel on machine. Fuel may damage surface. Wipe up spilled fuel immediately.
- Prolonged exposure to sunlight will damage hood surfaces.

Controls

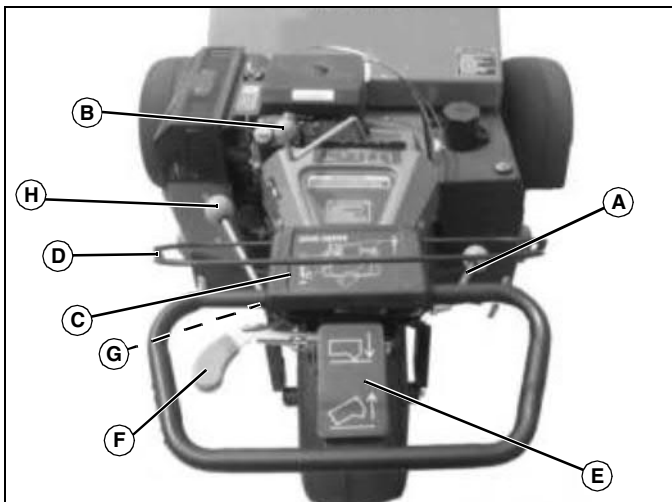

MX17109

- A - Park Brake Lever**
- B - Gear Selector**
- C - Operator Controls Decal**
- D - Operator Presence Bail**
- E - Aerator Engagement Switch**
- F - Throttle Lever**

G - Choke Lever

H - Travel Clutch Lever

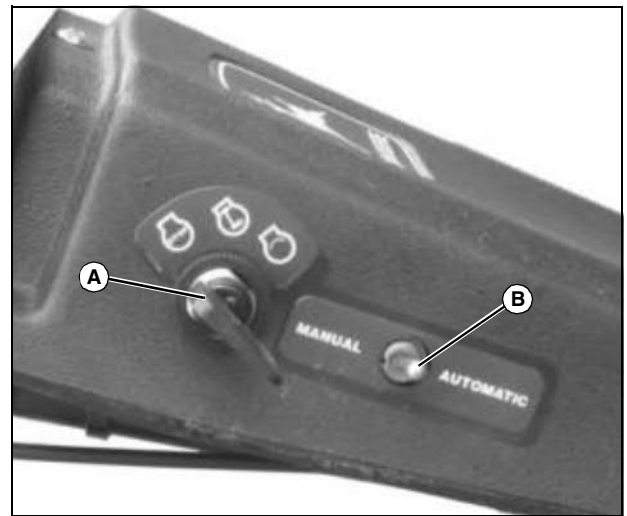

MX17110

A - Key Switch

B - Manual/Automatic Switch

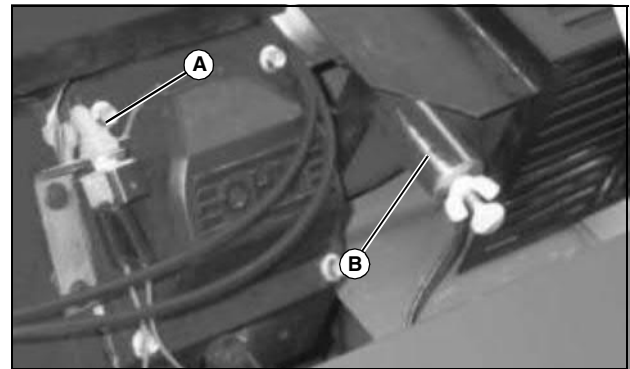

MX17111

A - Throttle Solenoid Switch

B - Throttle Solenoid

Adjusting Tine Coring Depth

IMPORTANT: Avoid damage! Do not operate the machine without the depth adjustment pins in place. Damage may occur to aeration head components.

Depth must be set equally with adjustment pins located on each side of the aeration head.

NOTE: Use three different-sized spacers, one 12.7 mm (0.5 in.) spacer, one 6.35 mm (0.25 in.) spacer and one 25.4 mm (1.0 in.) alone or in combination to provide tine depth range between 63.5 mm (2.5 in.) and 90 mm (3.5 in.).

OPERATING - MACHINE

Coring Depth	Spacer Placement
63.5 mm (2.5 in.)	Install 25.4 mm (1.0 in.) spacer below stop. Install remaining spacers above stop.
70 mm (2.75 in.)	Install 12.7 mm (0.5 in.) and 6.35 mm (0.25 in.) below stop. Install 25.4 mm (1.0 in.) spacer above.
76.2 mm (3.0 in.)	Install 12.7 mm (0.5 in.) spacer below stop. Install remaining spacers above stop.
90 mm (3.5 in.)	Install all spacers above stop.

1. Raise aeration head and place transport stops into Transport position. Lower aeration head onto stops.

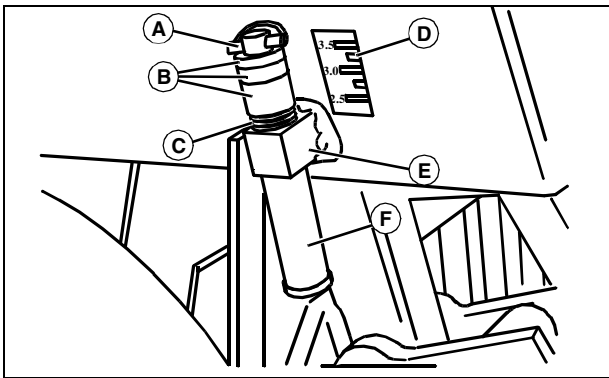

MIF

Picture Note: Set at depth of 90 mm (3.5 in.)

- Remove spring locking pin (A) from depth adjustment pin (F).
- Slide adjustment pin down through stop (E) to remove spacers (B) and spring (C) on pin above the stop.
- Use the depth indicator label (D) to set tine depth. Spring locking pin is aligned selected depth on label.
- Add or remove spacers (B) to adjustment pin below stop to achieve the desired depth.
- Insert adjustment pin through stop. Place spring (C) and spacers not used to set depth onto adjustment pin above stop.
- Install spring locking pin on adjustment pin to secure spacers.

Adjusting Holes-Per-Square-Foot Dimension

Holes per square foot are determined by the ground speed of the machine and the tine holder used.

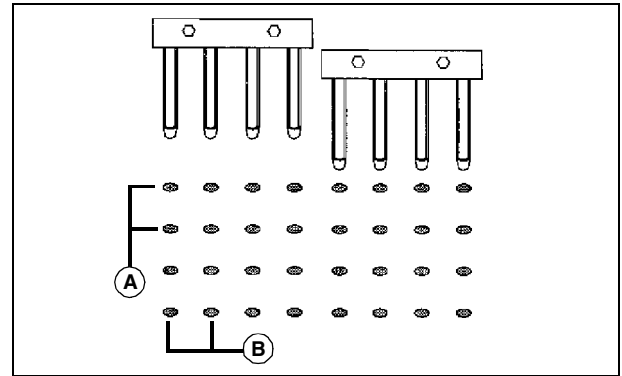

M86248

- Increasing the ground speed will reduce the number of holes per square foot, but will increase forward hole spacing (A) and increase the square feet aerated per hour.

- Changing from 4x holders to mini tine holders will decrease the tine hole spacing (B) and increase the number of holes per square foot.

Ground speed is determined based on the number of holes desired per square foot. Before beginning operation, take machine to practice area to determine needed speed to provide desired holes per square foot.

Testing Safety Systems

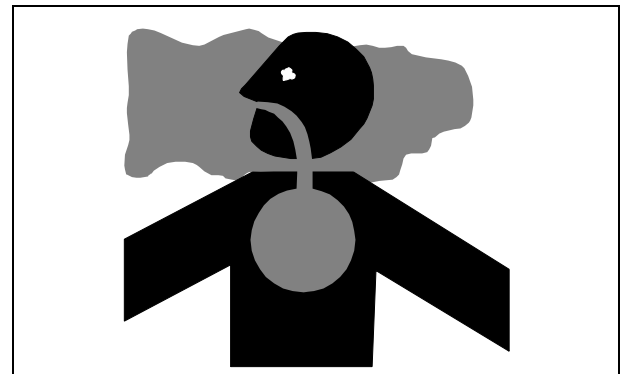

OPERATING - MACHINE



CAUTION: Avoid injury! Engine exhaust fumes contain carbon monoxide and can cause serious illness or death.

- Move the machine to an outside area before running the engine.
- Do not run an engine in an enclosed area without adequate ventilation.
- Connect a pipe extension to the engine exhaust pipe to direct the exhaust fumes out of the area.
- Allow fresh outside air into the work area to clear the exhaust fumes out.

The safety systems installed on your machine should be checked before each machine use. Be sure you have read the machine operator manual and are completely familiar with the operation of the machine before performing these safety system checks.

Use the following checkout procedures to check for normal operation of machine.

If there is a malfunction during one of these procedures, do not operate machine. **See your authorized dealer for service.**

Perform these tests in a clear open area. Keep bystanders away.

Testing Operator Presence Bail

1. Turn key to ON position.
2. Engage operator presence bail.
3. Pull clutch lever toward operator.
4. Lower aeration head.
5. Release operator presence bail.

Result: The drive clutch and clutch lever will disengage. The aeration head will fully rise.

Testing Park Brake

1. Inflate tires to correct pressures.
2. Stop machine on a 17° slope (30% grade). Stop engine and lock park brake.

Result: Park brake must hold the machine stationary. Machine should move no more than 61 cm (24 in.) in one hour. If machine moves more than that, brake needs to be adjusted. (See Adjusting Park Brake).

Using Key Switch

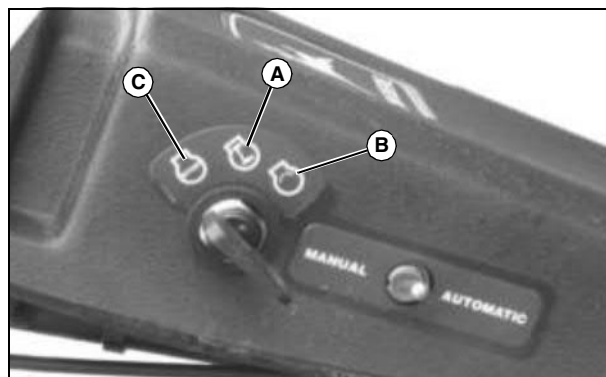

MX17110

1. Turn the key to the ON position (A) to allow the aeration head to be raised or lowered without the engine running.
2. Turn the key to the START position (B) to start the machine.
3. Turn the key to the STOP position (C) to stop the engine or to hold the aeration head in a lowered position.

Using Choke Lever

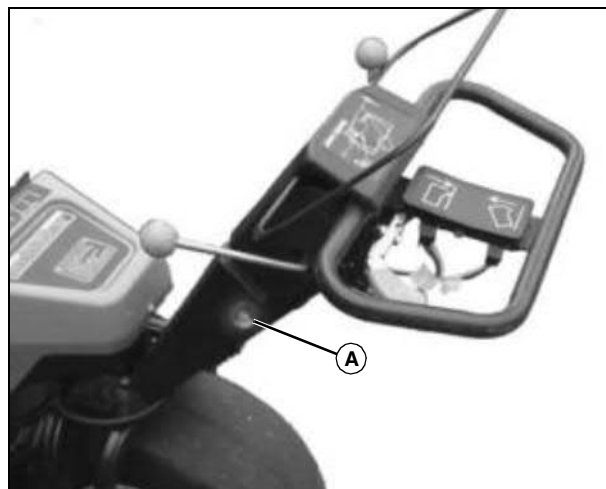

MX17112

1. Pull choke lever (A) out for the choke position when starting a cold engine.
2. After engine has started, push choke lever in completely.

OPERATING - MACHINE

Using Throttle Lever

NOTE: Adjust throttle lever depending on ground contour and condition of green.

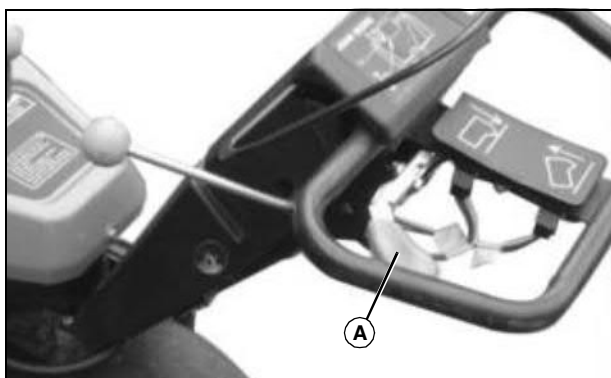

MX17113

1. Push lever (A) down to increase engine speed.
2. Pull lever (A) up to decrease engine speed.

Using Operator Presence Bail

NOTE: When bail (A) is released at any time, the drive clutch and lever (B) will automatically disengage and the aeration head will stop rotating and fully rise.

When key is in STOP position and head is down, the head will rise when key is turned to ON position.

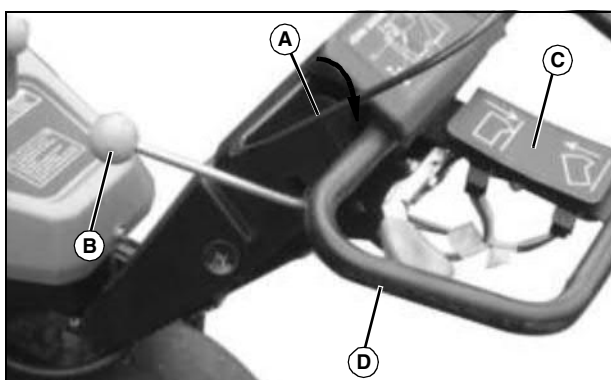

MX17113

1. The operator presence bail (A) permits engagement of the drive clutch (B), and operation of the aeration engagement switch (C), when squeezed to the handlebar (D).
2. Hold the operator presence bail to the handlebar to allow forward or reverse motion of the machine and to lower or raise the aeration head.

Using Park Brake

IMPORTANT: Avoid damage! Unlock park brake before engaging clutch lever to begin forward motion. Alarm will sound if travel clutch is engaged while park brake is locked. Damage to brake will occur if machine travels with brake locked.

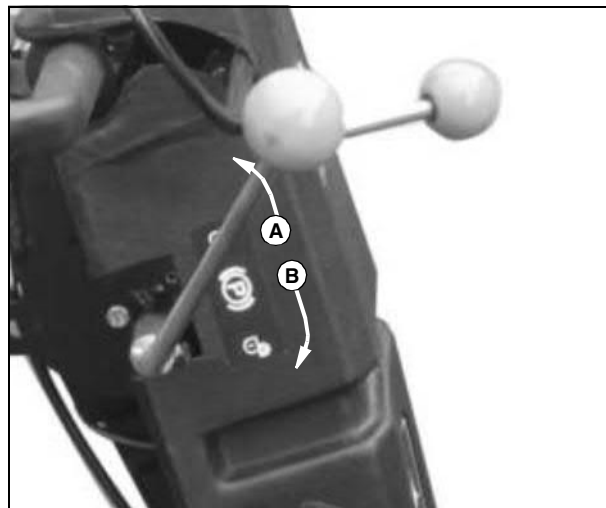

MX17114

1. Lock the park brake by rotating the lever toward the operator station (A).
2. Unlock the park brake by rotating the lever toward the engine (B).

OPERATING - MACHINE

Using Travel Clutch Lever

CAUTION: Avoid injury! Machine movement may start quickly if forward or reverse travel is started with throttle speed set at high RPM.

- Begin machine travel with throttle at low RPM. Adjust RPM after machine begins travel.

IMPORTANT: Avoid damage! Unlock park brake before engaging clutch lever to begin forward motion. Alarm will sound if travel clutch is engaged while park brake is locked. Damage to brake will occur if machine travels with brake locked.

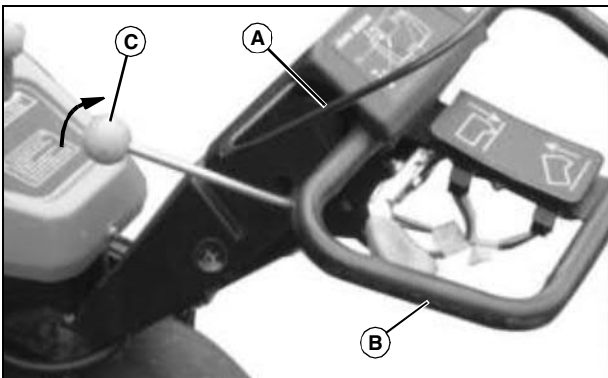

MX17113

1. Hold bail (A) to handlebar (B).
2. Start engine. Position throttle for low engine RPM.
3. Unlock park brake.
4. Select travel gear.
5. Pull clutch lever (C) toward the operator to engage drive clutch.

NOTE: If alarm sounds when clutch lever is engaged, raise aeration head completely and release bail to stop travel. Unlock park brake before continuing.

6. Machine will begin travel motion.
7. Adjust throttle to higher engine RPM as necessary.
8. Release bail (A) to stop travel. Travel clutch lever must return to disengage position. Machine must stop travel motion.

Using Aerator Engagement Switch

Raise or Lower Aeration Head Manually or Automatically with Engine Off

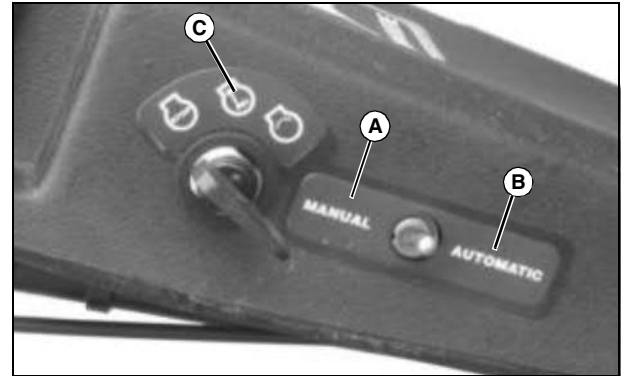

MX17110

1. Put MANUAL/AUTOMATIC switch in MANUAL (A) or AUTOMATIC position (B).
2. Turn key to ON position (C).

NOTE: When bail (D) is released at any time, the drive clutch and lever (F) will automatically disengage and the aeration head will stop rotating and fully rise.

When key is in STOP position and head is down, the head will rise when key is turned to ON position.

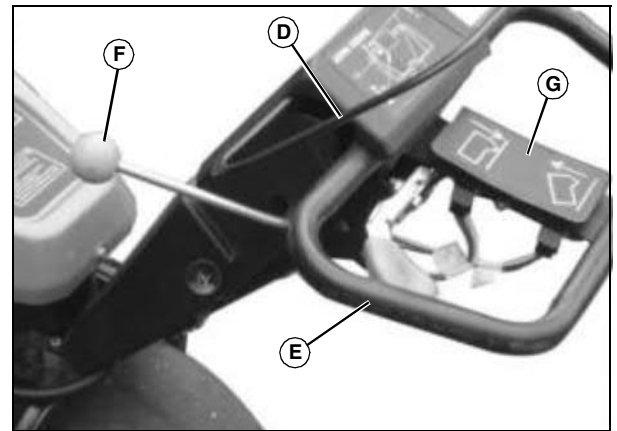

MX17113

3. Hold bail (D) to handlebar (E).
4. Pull clutch lever (F) toward the operator to engage drive clutch.
5. Change head position.

With switch in Manual position:

- To lower: push and hold the aerator engagement switch (G) in the direction of the aeration head.
- To raise: push and hold the aerator engagement switch (G) toward the operator.

OPERATING - MACHINE

With switch in Automatic position:

- To lower: push the aerator engagement switch (G) in the direction of the aeration head and release.
- To raise: push the aerator engagement switch (G) toward the operator and release.

6. Turn key to STOP position. Release bail.

Raise or Lower Aeration Head Manually or Automatically During Aeration Operation

CAUTION: Avoid injury! Keep hands and feet away from the tine area while the engine is running. When the engine is running, tining action will begin as soon as the aeration head begins to lower.

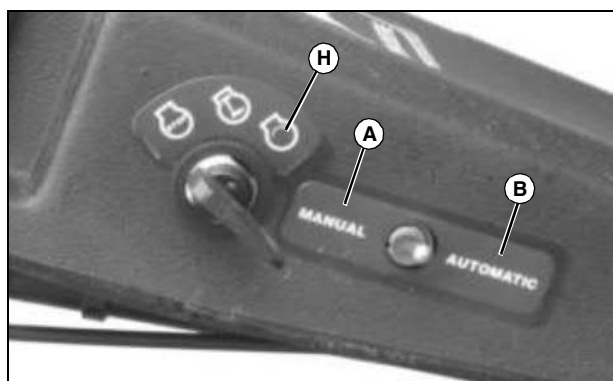

MX17110

1. Put manual/automatic switch to MANUAL (A) or AUTOMATIC position (B).
2. Rotate key to start position (H), and start engine.

NOTE: When bail (D) is released at any time, the drive clutch and lever (F) will automatically disengage and the aerator head will stop rotating and fully rise.

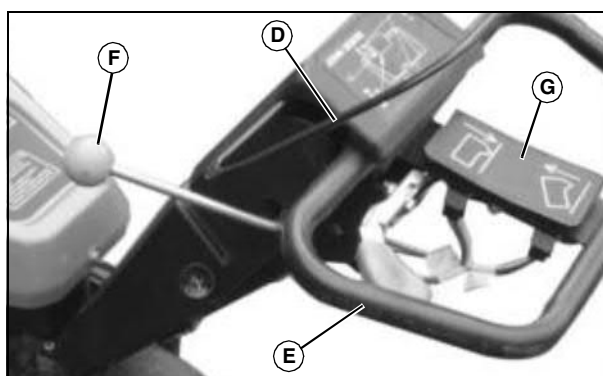

MX17113

3. Hold bail (D) to handlebar (E).
4. Pull clutch lever (F) toward the operator to engage drive clutch.
5. Change head position.

With switch in Manual position:

- To lower: push and hold the aerator engagement switch (G) in the direction of the aeration head.
- To raise: push and hold the aerator engagement switch (G) toward the operator.

With switch in Automatic position:

- To lower: push the aerator engagement switch (G) in the direction of the aeration head and release.
- To raise: push the aerator engagement switch (G) toward the operator and release.

Using Operator Controls Decal

NOTE: The operator controls decal is located on the steering handle console. It is designed to be a quick reference for operators to understand basic control functions.

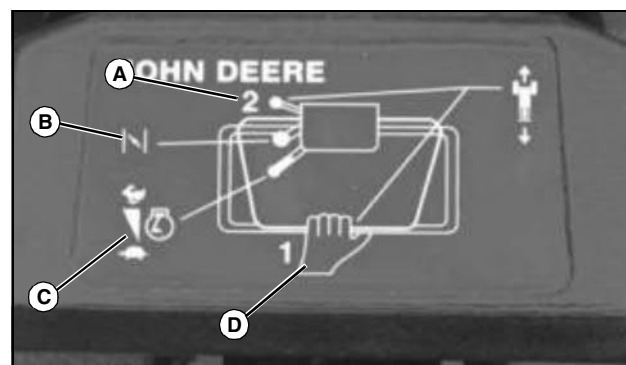

M88416

1. Figures 1 and 2 (D and A) indicate that the operator bail (D) must be held down and the travel clutch lever (A) must be pulled toward the operator to engage machine travel in either direction.
2. Key (B) indicates the location of the choke.
3. Key (C) indicates the location of the throttle.

OPERATING - MACHINE

Starting The Engine

IMPORTANT: Avoid damage! Aeration head must be fully raised before starting engine or machine travel. Tining action will begin if head is not fully raised.

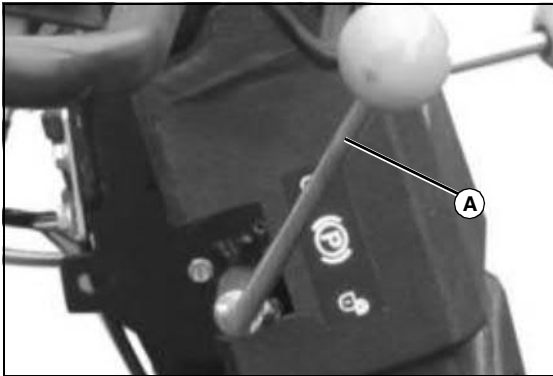

MX17114

1. Lock park brake (A).
2. Raise the aeration head completely.

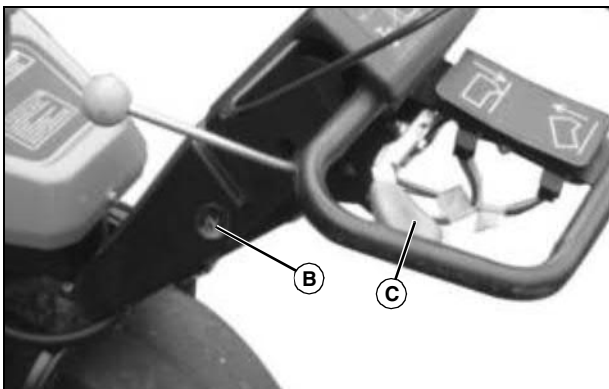

MX17113

3. Pull choke (B) out to set choke at closed position.
4. Set throttle lever (C) midway between slow and fast positions.

IMPORTANT: Avoid damage! Do not crank the engine continuously for more than 10 seconds at a time. If the engine does not start, wait 60 seconds before attempting to start the engine again.

5. Turn key to on position.
6. Adjust choke position:
 - For a warm engine: move choke to open position after engine has started.
 - For a cold engine: Gradually return the choke to the open position after allowing the engine to warm up.

Stopping The Engine

NOTE: When bail (A) is released at any time, the drive clutch and lever (B) will automatically disengage and the aeration head will stop rotating and fully rise.

When key is in STOP position and head is down, the head will raise when key is turned to ON position.

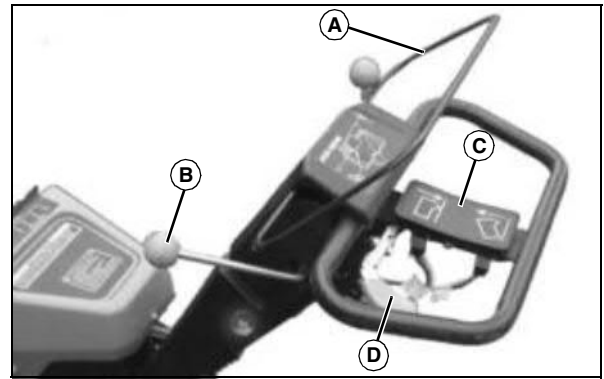

MX17111

1. Raise aeration head.
 - With MANUAL/AUTOMATIC switch in MANUAL position
Push and hold the aerator engagement switch (C) toward the operator to raise aeration head and disengage drive belt. Tines should raise completely and stop coring action.
 - With MANUAL/AUTOMATIC switch in AUTOMATIC position
Push and release the aerator engagement switch (C) toward the operator to raise aeration head and disengage drive belt. Tines should raise completely and stop coring action.
2. Release bail (A) to stop machine forward motion.
3. Set the throttle lever (D) midway between slow and fast positions and allow the engine to run for a minimum of 15 seconds.
4. Pull throttle lever all the way up (toward operator).
5. Turn key to off position.



Suggest:

If the above button click is invalid.

Please download this document

first, and then click the above link

to download the complete manual.

Thank you so much for reading

OPERATING - MACHINE

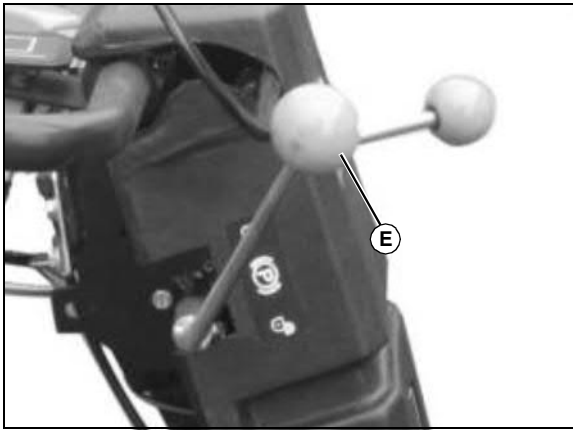

MX17114

6. Lock park brake (E).

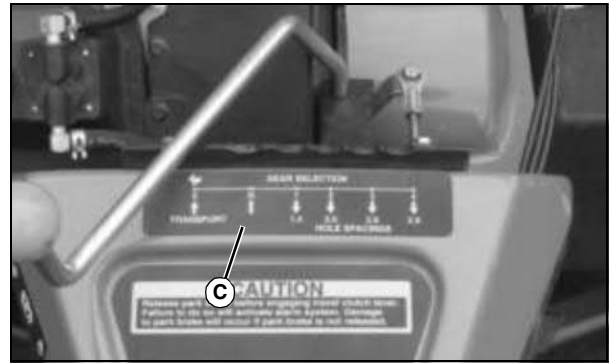

MX17116

- Position the gear selector on “1” through “4” to select a forward aerating speed. Refer to the decal (C) or see Selecting Travel Speed in this section to determine proper operating speed for the current operating conditions.

Determining Travel Direction

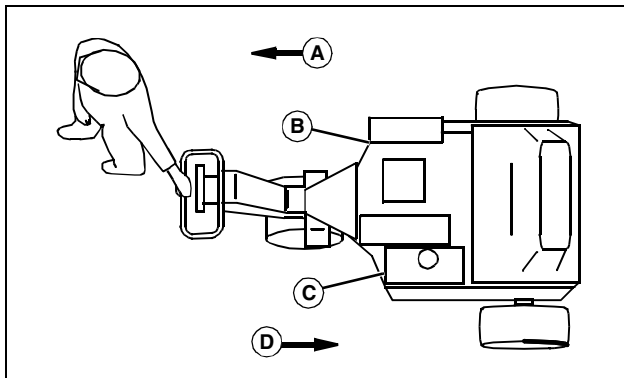

MIF

- A - Forward**
- B - Right Side**
- C - Left Side**
- D - Transport**

Right and left sides are determined by facing in the direction the machine will travel when going forward.

Selecting Travel Gears

NOTE: When a forward speed is selected, the machine moves in the direction of the operator station.

When in transport, the machine moves away from the operator station.

- Position the gear selector on “5” to move the aerator in transport, away from the operator station. Transport is used to travel to worksites.

Selecting Travel Speed

IMPORTANT: Avoid damage! Unlock park brake before engaging clutch lever to begin forward motion. Alarm will sound if travel clutch is engaged while park brake is locked. Damage to brake will occur if machine travels with brake locked.

NOTE: There are four forward travel speeds and one reverse travel speed.

1st gear (Mini-tines)	35.6 mm x 35.6 mm (1.4 in. x 1.4 in.) pattern
2nd gear	50.8 mm x 50.8 mm (2.00 in. x 2.00 in.) pattern
3rd gear	66.5 mm x 50.8 mm (2.62 in. x 2.00 in.) pattern
4th gear	73.6 mm x 50.8 mm (2.90 in. x 2.00 in.) pattern
TRANSPORT	Transport to work site

<https://www.ebooklibonline.com>

Hello dear friend!

Thank you very much for reading.

Enter the link into your browser.

The full manual is available for immediate download.

<https://www.ebooklibonline.com>