

JOHN DEERE
WORLDWIDE COMMERCIAL & CONSUMER
EQUIPMENT DIVISION

Mini-Frame Z-Trak®
717A and 727A

OMTCU18172 A4

OPERATOR'S MANUAL

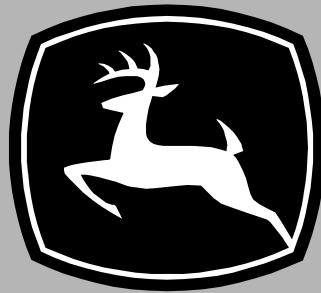

JOHN DEERE

⚠ WARNING: The Engine Exhaust from this product contains chemicals known to the State of California to cause cancer, birth defects or other reproductive harm.

California Proposition 65 Warning

North American Version
Litho in U.S.A.

INTRODUCTION

Thank You for Purchasing a John Deere Product

We appreciate having you as a customer and wish you many years of safe and satisfied use of your machine.

Using Your Operator's Manual

This manual is an important part of your machine and should remain with the machine when you sell it.

Reading your operator's manual will help you and others avoid personal injury or damage to the machine.

Information given in this manual will provide the operator with the safest and most effective use of the machine.

Knowing how to operate this machine safely and correctly will allow you to train others who may operate this machine.

If you have an attachment, use the safety and operating information in the attachment operator's manual along with the machine operator's manual to operate the attachment safely and correctly.

This manual and safety signs on your machine may also be available in other languages (see your authorized dealer to order).

Sections in your operator's manual are placed in a specific order to help you understand all the safety messages and learn the controls so you can operate this machine safely. You can also use this manual to answer any specific operating or servicing questions. A convenient index located at the end of this book will help you to find needed information quickly.

The machine shown in this manual may differ slightly from your machine, but will be similar enough to help you understand our instructions.

RIGHT-HAND and LEFT-HAND sides are determined by facing in the direction the machine will travel when going forward. When you see a broken line arrow (----->), the item referred to is hidden from view.

Before delivering this machine, your dealer performed a predelivery inspection to ensure best performance.

Special Messages

Your manual contains special messages to bring attention to potential safety concerns, machine damage as well as helpful operating and servicing information. Please read all the information carefully to avoid injury and machine damage.



CAUTION: Avoid injury! This symbol and text highlight potential hazards or death to the operator or bystanders that may occur if the hazards or procedures are ignored.

IMPORTANT: Avoid damage! This text is used to tell the operator of actions or conditions that might result in damage to the machine.

NOTE: General information is given throughout the manual that may help the operator in the operation or service of the machine.

PRODUCT IDENTIFICATION

Record Identification Numbers

Mini-Mount Z-Trak® 717A and 727A PIN (010001-)

If you need to contact an Authorized Service Center for information on servicing, always provide the product model and serial number.

You will need to locate the model and serial number for the machine and for the engine of your machine and record the information in the spaces provided below.

DATE OF PURCHASE:

DEALER NAME:

DEALER PHONE:



MX18376

PRODUCT IDENTIFICATION NUMBER (A):



MX18377

ENGINE SERIAL NUMBER (B):

<https://www.ebooklibonline.com>

Hello dear friend!

Thank you very much for reading.

Enter the link into your browser.

The full manual is available for immediate download.

<https://www.ebooklibonline.com>

TABLE OF CONTENTS

Safety	1
Operating	10
Replacement Parts	23
Service Intervals	24
Service Lubrication	25
Service Engine	27
Service Transmission	33
Service Steering & Brakes.....	38
Service Mower	40
Service Electrical.....	44
Service Miscellaneous.....	46
Troubleshooting	49
Storage	53
Specifications	55
Warranty	58
Index.....	61

All information, illustrations and specifications in this manual are based on the latest information at the time of publication. The right is reserved to make changes at any time without notice.

COPYRIGHT© 2004
Deere & Co.
John Deere Worldwide Commercial and
Consumer Equipment Division
All rights reserved
Previous Editions
COPYRIGHT© 2003

OMTCU18172 A4 - English

SAFETY

Understanding The Machine Safety Labels

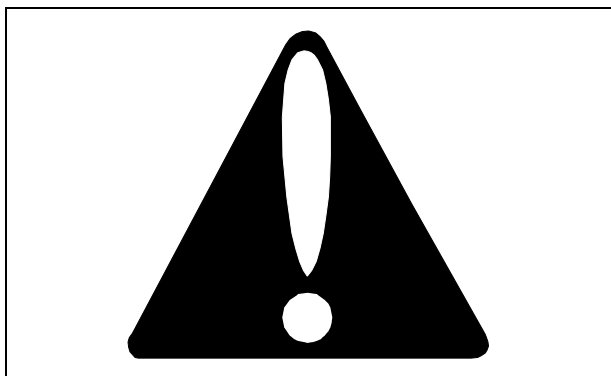

Safety-Alert Symbol

The machine safety labels shown in this section are placed in important areas on your machine to draw attention to potential safety hazards.

On your machine safety labels, the words DANGER, WARNING, and CAUTION are used with this safety-alert symbol. DANGER identifies the most serious hazards.

The operator's manual also explains any potential safety hazards whenever necessary in special safety messages that are identified with the word, CAUTION, and the safety-alert symbol.

DANGER

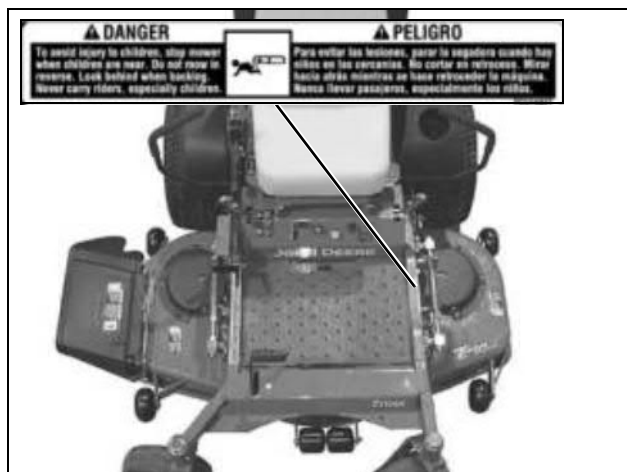

TCU16827/MX18378

- To avoid injury to children, stop mower when children are near. Do not mow in reverse. Look behind when backing. Never carry riders, especially children.

DANGER

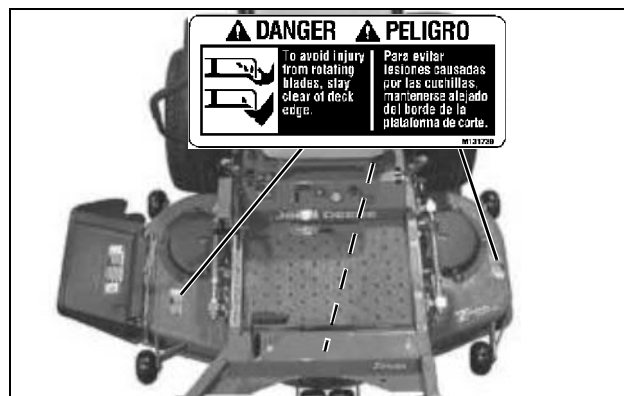

M131739/MX18378

- To avoid injury from rotating blades, stay clear of deck edge.

DANGER



M137637/MX18379

- Do not mow without discharge chute or entire grass catcher in place.

DANGER

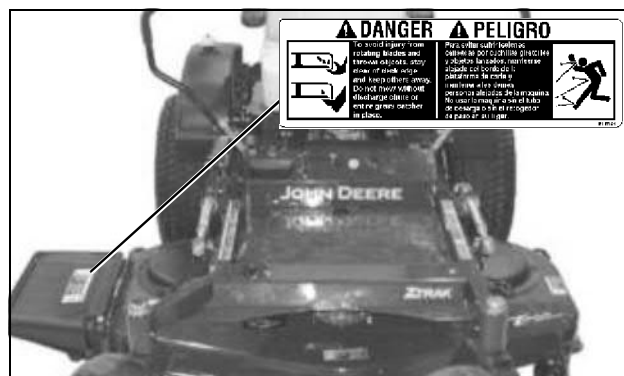

M131748/MX18385

SAFETY

- To avoid injury from rotating blades and thrown objects, stay clear of deck edge and keep others away. Do not mow without discharge chute or entire grass catcher in place.

- Hot surface.

DANGER/POISON



MX10396/MX18386

- Shield Eyes: Explosive gases can cause blindness or injury.
- NO:
 - Sparks
 - Flames
 - Smoking
- Sulfuric acid can cause blindness or severe burns.
- Flush eyes immediately with water. Get medical help fast.
- Keep out of reach of children.
- Do not tip.
- Do not open battery.

WARNING



M134406/MX18376

WARNING



MX16827/MX18378

- To avoid injury from tipover, drive across slopes, not up and down. If machine stops going uphill, stop blades and back down slowly.

WARNING



TCU51051/MX18379

- To avoid injury from rotating belts, keep all shields and guards in place.

SAFETY

CAUTION: HELP AVOID INJURY

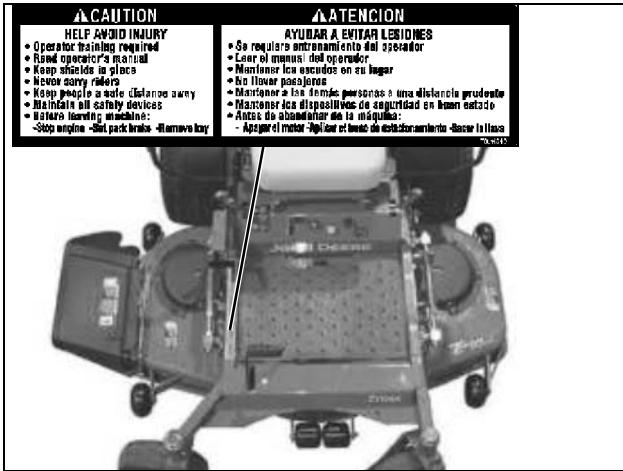

TCU14840/MX18378

- Operator training required
- Read operator's manual
- Keep shields in place
- Never carry riders
- Keep people a safe distance away
- Maintain all safety devices
- Before leaving machine:
 - Stop engine
 - Set park brake
 - Remove key

Emission Control System Certification Label

NOTE: Tampering with emission controls and components by unauthorized personnel may result in severe fines or penalties. Emission controls and components can only be adjusted by EPA and/or CARB authorized service centers. Contact your John Deere Commercial and Consumer Equipment Retailer concerning emission controls and component questions.

The presence of an emissions label signifies that the engine has been certified with the United States Environmental Protection Agency (EPA) and/or California Air Resources Board (CARB).

The emissions warranty applies only to those engines marketed by John Deere that have been certified by the EPA and/or CARB; and used in the United States and Canada in off-road mobile equipment.

Emission Compliance Period

If your engine has the emission compliance category listed on the emission control system certification or air index label, this indicates the number of operating hours for which the engine has been certified to meet EPA and/or CARB emission requirements. The following table provides the engine compliance period in hours associated with the category found on the certification label.

Agency	Category	Hours
EPA	C	250
EPA	B	500
EPA	A	1000
CARB	Moderate	125
CARB	Intermediate	250
CARB	Extended	500

Certification

Your product has been tested and evaluated by the manufacturer and conforms with American National Standard B-71.4, "Safety Specifications" for commercial turf care equipment.

Canadian Electromagnetic Compatibility (EMC) Compliance

This spark ignition system complies with Canadian ICES-002.

Operator Training Required

- The owner of the machine is responsible for training the users and mechanics of the machine.
- The owner/user can prevent and is responsible for accidents or injuries occurring to themselves, other people, or property.
- Do not allow operation or service of the machine by untrained adults.
- Do not let children operate the machine. Local regulations may restrict the age of the operator.
- Read the operator's manual and study the safety and operation sections before operating the machine.
- If the operator of the machine cannot read or understand this manual, it is the machine's owner

SAFETY

responsibility to explain this material to the operator. This publication is available in other languages.

- Operate the machine in an open, unobstructed area under the direction of an experienced operator.
- Learn the use of all controls.
- Operator experience is required to learn the moving, stopping, turning and other operating characteristics of the machine.

Operating Safely

- Inspect machine before you operate. Be sure hardware is tight. Repair or replace damaged, badly worn, or missing parts. Be sure guards and shields are in good condition and fastened in place. Make any necessary adjustments before you operate.
- Be sure all drives are in neutral and parking brake is locked before starting engine. Only start engine from the operator's position.
- Do not operate mower without discharge chute or entire grass catcher in place. Never operate with the discharge deflector raised, removed, or altered, unless using a grass catcher.
- Check before each use that operator presence controls are functioning correctly. Test safety systems. Do not operate unless they are functioning correctly.
- Do not operate machine if you are under the influence of drugs or alcohol.
- Do not change the engine governor setting or overspeed the engine.
- Check brake action before you operate. Adjust or service brakes as necessary.
- Stop machine if anyone enters the area.
- Never raise mower decks when blades are running.
- If you hit an object, stop and inspect the machine. Make repairs before you operate. Keep machine and attachments properly maintained and in good working order.
- Do not leave machine unattended when it is running.
- Only operate during daylight or with good artificial light.
- Slow down and be careful of traffic when operating near or crossing roadways. Stop blades before crossing roads or sidewalks. Use care when approaching blind corners, shrubs, trees, or other objects that may obscure vision.
- Be aware of the mower discharge direction and make sure that no one is in the path of the discharge direction.
- Use only accessories and attachments approved by the manufacturer of the machine.

- Do not wear radio or music headphones. Safe service and operation require your full attention.

Using a Spark Arrestor

The engine in this machine is not equipped with a spark arrestor muffler. It is a violation of California Public Resource Code Section 4442 to use or operate this engine on or near any forest-covered, brush-covered or grass-covered land unless the exhaust system is equipped with a spark arrestor meeting any applicable local or state laws. Other states or federal areas may have similar laws.

A spark arrestor for your machine may be available from your authorized dealer. An installed spark arrestor must be maintained in good working order by the operator.

Checking Mowing Area

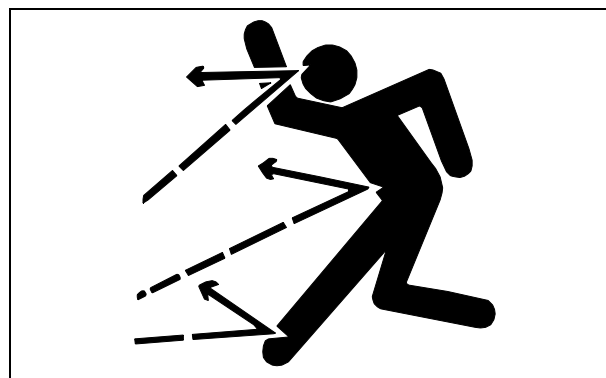

MIF

- Evaluate the terrain to determine what accessories and attachments are needed to properly and safely perform the job.
- Clear mowing area of objects that might be thrown. Keep people and pets out of mowing area.
- Low-hanging branches and similar obstacles can injure the operator or interfere with mowing operation. Before mowing, identify potential obstacles such as low-hanging branches, and trim or remove those obstacles.
- Study mowing area. Set up a safe mowing pattern. Do not mow where traction or stability is doubtful.
- Test drive area with mower lowered but not running. Slow down when you travel over rough ground.

Parking Safely

1. Stop machine on a level surface, not on a slope.
2. Move motion control levers out to the neutral lock

SAFETY

position.

3. Disengage mower blades.
4. Lower attachments to the ground.
5. Lock the park brake.
6. Stop the engine.
7. Remove the key.
8. Wait for engine and all moving parts to stop before you leave the operator's seat.
9. Close fuel shut-off valve, if your machine is equipped.
10. Disconnect the negative battery cable or remove the spark plug wire (for gasoline engines) before servicing the machine.

Rotating Blades are Dangerous

HELP PREVENT SERIOUS OR FATAL ACCIDENTS:

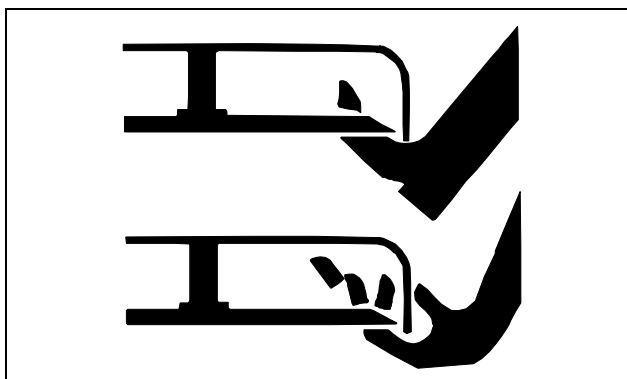

MIF

- Rotating blades can cut off arms and legs.
- Keep hands, feet and clothing away from mower deck when engine is running.
- Be alert at all times, drive forward carefully. People, especially children can move quickly into the mowing area before you know it.
- Before backing up, shut off PTO and look down and behind the machine carefully, especially for children.
- Do not mow in reverse.
- Shut off blades when you are not mowing.
- Park machine safely before inspecting or unplugging mower or bagger for any reason including emptying the catchers or unplugging the chute.

PROTECT CHILDREN:

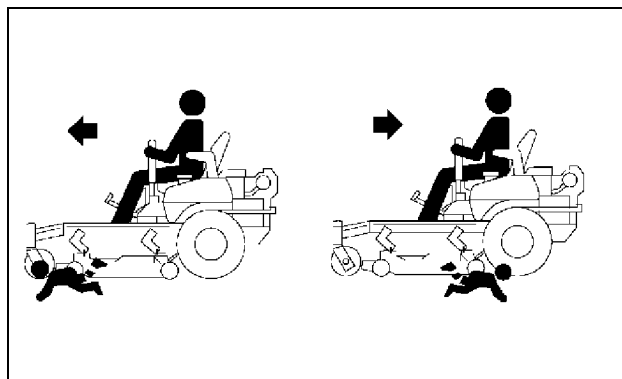

MIF

- Never assume that children will remain where you last saw them. Children are attracted to mowing activity, stay alert to the presence of children.
- Keep children indoors when you are mowing. Turn the machine off if a child enters the mowing area.
- Use extra care when you come to blind corners, shrubs, trees, or other objects that may block your vision.
- Do not let children or an untrained person operate the machine.
- Do not carry or let children ride on any attachment or machine even with the blades off. Do not tow children in a cart or trailer.

Avoid Tipping

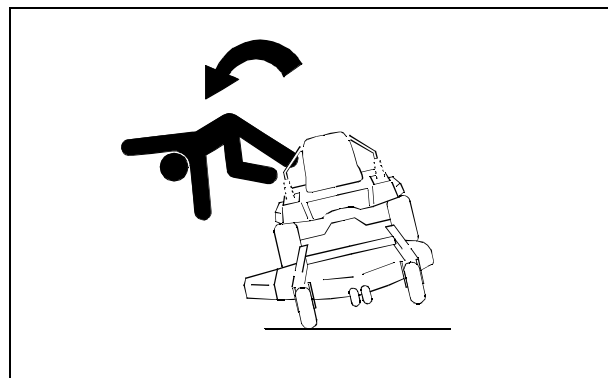

MIF

- Slopes are a major factor related to loss-of-control and tip-over accidents, which can result in severe injury or death. All slopes require extra caution. If you cannot back up the slope or if you feel uneasy on it, do not mow it.
- Drive across a hill, not up and down.
- Keep all movement on slopes slow and gradual. Do not make sudden changes in speed or direction.
- Use a slow speed when operating on a slope. Choose a

SAFETY

low gear or speed so that you will not have to stop or shift while on the slope.

- Tires may lose traction on slopes even though the brakes are functioning properly.
- Do not turn on slopes unless necessary. Turn slowly and turn downhill. Do not shift to neutral and coast downhill.
- Stay alert for holes and other hidden hazards in the terrain. Uneven terrain could overturn the machine. Tall grass can hide obstacles.
- Keep away from drop-offs, ditches and embankments. The machine could suddenly turn over if a wheel is over the edge of a cliff or ditch, or if an edge caves in.
- Use extra care with grass catchers or other attachments. These can change the stability of the machine. Do not use grass catcher on steep slopes.
- Follow the manufacturer's recommendations for wheel weights or counterweights for added stability when operating on slopes or using front or rear mounted attachments. Remove weights when not required.
- Transport machine with decks lowered to improve stability.
- Drive machine very slowly and avoid quick stops when attachment is removed.
- Operating machine when grass is wet can cause reduced traction and sliding.

Keep Riders Off

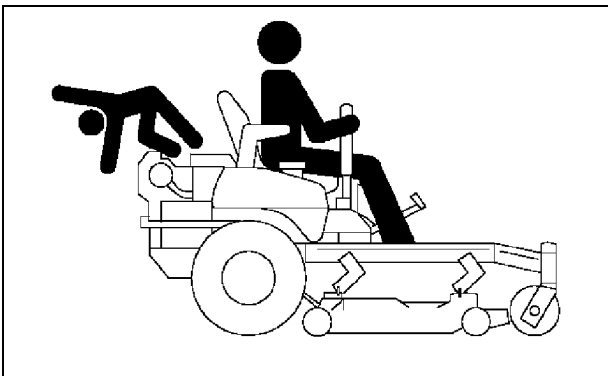

MIF

- Only allow the operator on the machine. Keep riders off.
- Riders on the machine or attachment may be struck by foreign objects or thrown off the machine causing serious injury.
- Riders obstruct the operator's view resulting in the machine being operated in an unsafe manner.

Checking Wheel Bolts

- A serious accident could occur causing serious injury if wheel bolts are not tight.
- Check wheel bolt tightness often during the first 100 hours of operation.
- Wheel hardware must be tightened to specified torque using the proper procedure anytime it is loosened.

Wear Appropriate Clothing



MIF

- Always wear safety goggles, or safety glasses with side shields, and a hard hat when operating the machine.
- Wear close fitting clothing and safety equipment appropriate for the job.
- While mowing, always wear substantial footwear and long trousers. Do not operate the equipment when barefoot or wearing open sandals.
- Wear a suitable protective device such as earplugs. Loud noise can cause impairment or loss of hearing.

Driving Safely on Public Roads

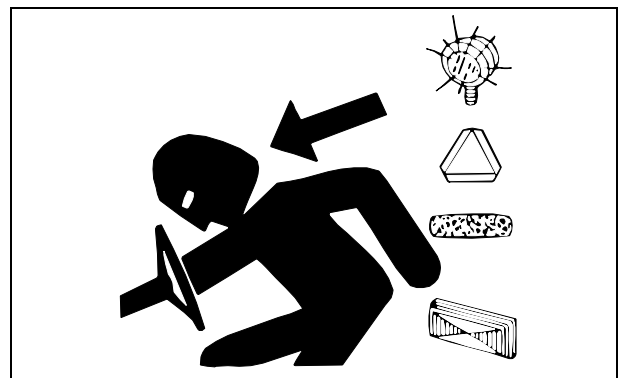

MIF

- Use safety lights and devices. Slow moving machines

SAFETY

when driven on public roads are hard to see, especially at night.

- Whenever driving on public roads, use flashing warning lights and turn signals according to local regulations. Extra flashing warning lights may need to be installed.

Practice Safe Maintenance



MIF

- Only qualified, trained adults should service this machine.
- Understand service procedure before doing work. Keep area clean and dry.
- Do not operate the engine in a confined space where dangerous carbon monoxide fumes can collect.
- Never lubricate, service, or adjust machine while it is moving. Keep safety devices in place and in working condition. Keep hardware tight.
- Keep hands, feet, clothing, jewelry, and long hair away from any moving parts, to prevent them from getting caught.
- Lower attachments to the ground before servicing machine. Disengage all power and stop the engine. Lock park brake and remove the key. Let machine cool.
- Disconnect battery or remove spark plug wire (for gasoline engines) before making any repairs.
- Before servicing machine, carefully release pressure from any components with stored energy, such as hydraulic components.
- Keep all nuts and bolts tightened, especially blade attachment bolts.
- Securely support any machine elements that must be raised for service work. Use jack stands or lock service latches to support components when needed.
- Never run engine unless park brake is locked.
- Keep all parts in good condition and properly installed. Fix damage immediately. Replace worn or broken parts.

Replace all worn or damaged safety and instruction decals.

- Grass catcher components are subject to wear, damage, and deterioration which could expose moving parts or allow objects to be thrown. Check components frequently and replace with manufacturer's recommended parts when necessary.
- To prevent fires, remove any buildup of grease, oil, or debris from the machine, especially the engine compartment.
- Charge batteries in an open, well-ventilated area, away from sparks. Unplug battery charger before connecting or disconnecting from the battery. Wear protective clothing and use insulated tools.
- Do not modify machine or safety devices. Unauthorized modifications may impair its function and safety.

Avoid High Pressure Fluids



MIF

- Hydraulic hoses and lines can fail due to physical damage, kinks, age, and exposure. Check hoses and lines regularly. Replace damaged hoses and lines.
- Hydraulic fluid connections can loosen due to physical damage and vibration. Check connections regularly. Tighten loose connections.
- Escaping fluid under pressure can penetrate the skin causing serious injury. Avoid the hazard by relieving pressure before disconnecting hydraulic or other lines. Tighten all connections before applying pressure.
- Search for leaks with a piece of cardboard. Protect hands and body from high pressure fluids.
- If an accident occurs, see a doctor immediately. Any fluid injected into the skin must be surgically removed within a few hours or gangrene may result. Doctors unfamiliar with this type of injury should reference a knowledgeable medical source. Such information is available from Deere & Company Medical Department in Moline, Illinois, U.S.A. Information may be obtained in the United States and Canada only by calling 1-800-822-8262.

SAFETY

Prevent Fires

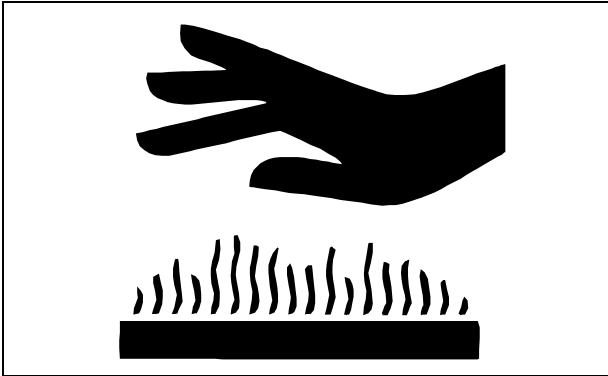

- Remove grass and debris from engine compartment and muffler area, before and after operating machine, especially after mowing or mulching in dry conditions.
- To reduce fire hazard, keep engine and engine compartment free of grass, leaves, or excessive grease.
- Allow engine to cool before storing in any enclosure.
- Never remove fuel cap, or add fuel with engine running or hot. Allow engine to cool for several minutes.
- Never store equipment with fuel in the tank inside a building where fumes may reach an open flame or spark.

Tire Safety



Explosive separation of a tire and rim parts can cause serious injury or death:

- Do not attempt to mount a tire without the proper equipment and experience to perform the job.
- Always maintain the correct tire pressure. Do not inflate the tires above the recommended pressure. Never weld or heat a wheel and tire assembly. The heat can cause an increase in air pressure resulting in a tire explosion. Welding can structurally weaken or deform the wheel.

- When inflating tires, use a clip-on chuck and extension hose long enough to allow you to stand to one side and NOT in front of or over the tire assembly.
- Check tires for low pressure, cuts, bubbles, damaged rims or missing lug bolts and nuts.

Handling Fuel Safely

Fuel and fuel vapors are highly flammable:



- Do not refuel machine while you smoke, when machine is near an open flame or sparks, or when engine is running. Stop engine and allow to cool before filling.
- Never remove the fuel cap or add fuel with the engine running.
- Never fill fuel tank or drain fuel from a machine in an enclosed area. Fill fuel tank outdoors.
- Prevent fires. Clean up spilled fuel immediately. If fuel is spilled on clothing, change clothing immediately.
- Do not store fuel in container or machine with fuel in tank in a building where fumes may reach an open flame or spark.
- Prevent fire and explosion caused by static electric discharge. Use only non-metal, portable fuel containers approved by the Underwriter's Laboratory (U.L.) or the American Society for Testing & Materials (ASTM). If using a funnel, make sure it is plastic and has no screen or filter.

SAFETY

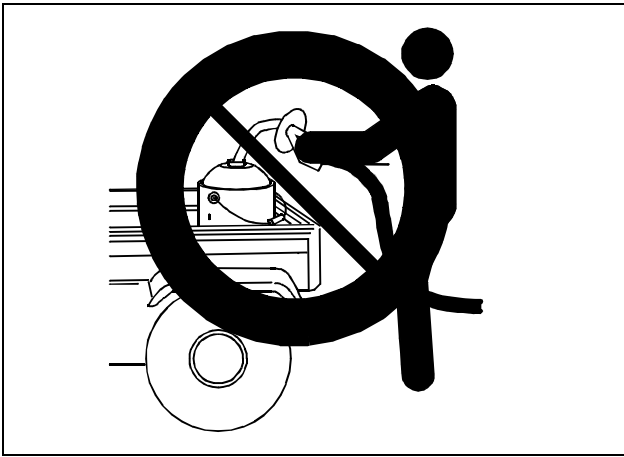

safety procedures, and emergency response techniques. The seller of the chemical products used with your machine is responsible for providing the MSDS for that product.

- Static electric discharge can ignite gasoline vapors in an ungrounded fuel container. Remove the fuel container from the bed of a machine or trailer or the trunk of a car and place on the ground away from the machine before filling. Keep nozzle in contact with container opening while filling. Do not use a nozzle lock-open device.
- When practical, remove equipment from trailers or truck beds and refuel them on the ground. If this is not possible, use a portable, plastic fuel container to refuel equipment on a truck bed or trailer.
- For gasoline engines, do not use gas with methanol. Methanol is harmful to your health and to the environment.

Handling Waste Product and Chemicals

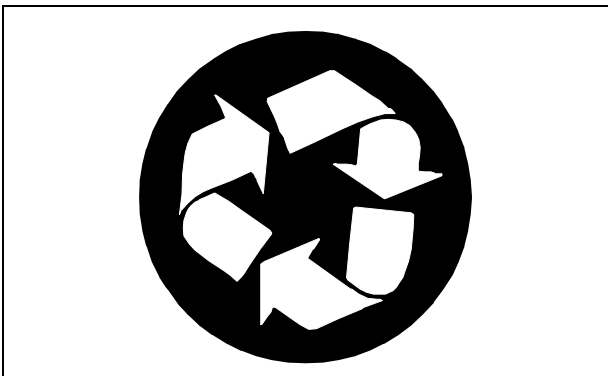

Waste products, such as, used oil, fuel, coolant, brake fluid, and batteries, can harm the environment and people:

- Do not use beverage containers for waste fluids - someone may drink from them.
- See your local Recycling Center or authorized dealer to learn how to recycle or get rid of waste products.
- A Material Safety Data Sheet (MSDS) provides specific details on chemical products: physical and health hazards,

OPERATING

Daily Operating Checklist

- Make sure all necessary guards and shields are safely and securely attached. Check for loose, missing, or damaged parts.
- Remove mower deck belt shields. Clean grass and debris from belt area.
- Remove grass and debris from machine and mower deck.
- Test park brake.
- Test safety systems.
- Check battery.
- Check for oil leaks.
- Check engine and hydraulic oil levels.
- Check all belts for damage or cracking.
- Check engine air filter.
- Check mower level.
- Adjust cutting height if necessary.
- Check wheel bolt torque. Tighten if necessary.
- Check tire air pressure. Check tires for damage or cracking.
- Check and adjust steering control linkages.
- Lubricate front caster spindles/wheels, if equipped.

Avoid Damage to Plastic and Painted Surfaces

- Do not wipe plastic parts unless rinsed first.
- Insect repellent spray may damage plastic and painted surfaces. Do not spray insect repellent near machine.
- Be careful not to spill fuel on machine. Fuel may damage surface. Wipe up spilled fuel immediately.

Operator Station Controls

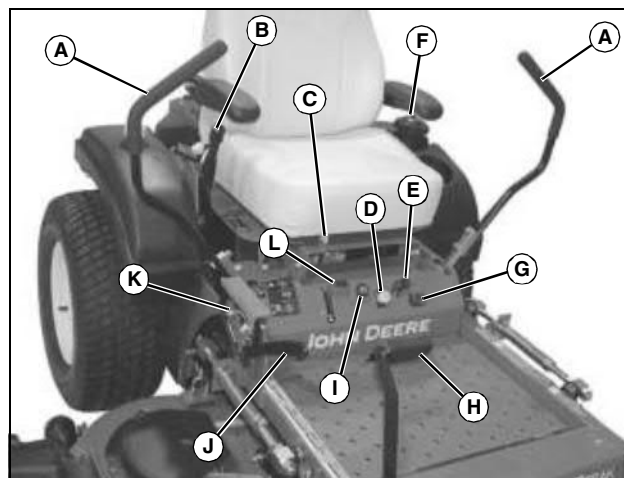

MX18400

- A - Motion Control Levers
- B - Park Brake Lever
- C - Seat Adjustment Lever
- D - PTO Knob
- E - Ignition Key Switch
- F - Fuel Cap
- G - Hour Meter
- H - Mower Deck Lift/Lower Pedal
- I - Choke
- J - Mower Deck Transport Position Lock Lever
- K - Height-of-Cut (HOC) Adjustment Pin
- L - Throttle Lever

Miscellaneous Controls



MX18386

- A - Fuel Shut-Off Valve
- B - Fuel Tank Cap

OPERATING

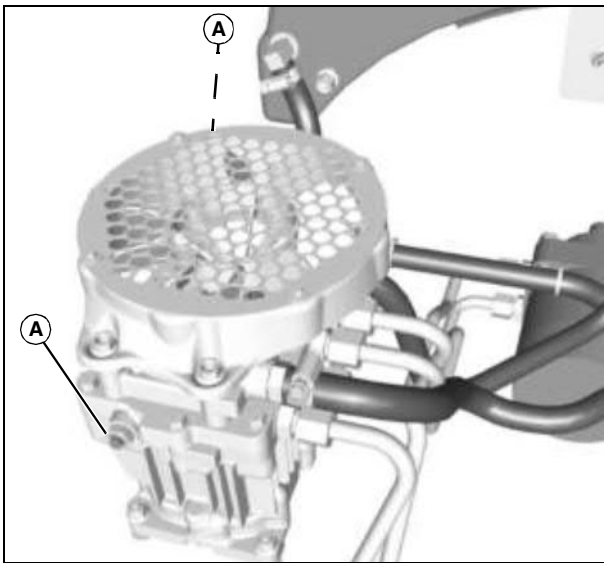

MX18483

A - Free-Wheeling Pump Release Valves (2 used, one on each side)

2. Push operator seat back and slowly lower seat frame.

Mounting and Dismounting Machine Safely

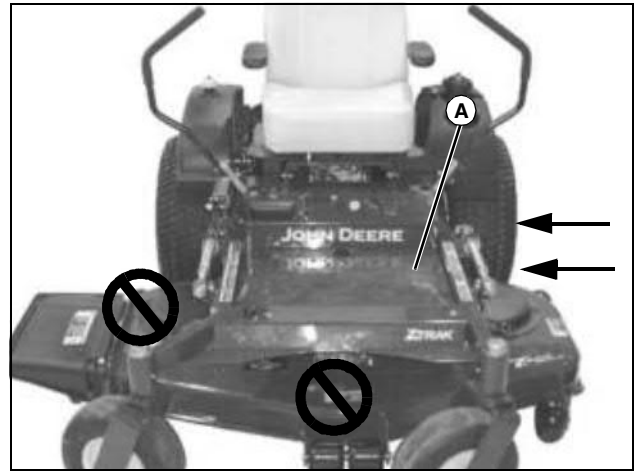

MX18385

Do not step on the mower deck when mounting and dismounting the machine. Mount the machine from the left side using the foot plate (A). Park machine safely (see Parking Safely in the SAFETY section) before dismounting.

Keep the foot plate clean.

Raising and Lowering Operator Seat



CAUTION: Avoid injury! The seat is heavy and can cause injury if it falls. When performing any service function under the operator seat, make sure the seat is tilted forward and rests against the hinge stops.

Raising the Seat

1. Park machine safely. (See Parking Safely in the SAFETY section.)



MX18401

2. Lift seat frame (A) and tilt forward until it rests against the hinge stops.

Lowering the Seat

1. Stand on the side of the machine.

Adjusting Seat

1. Sit on operator seat.

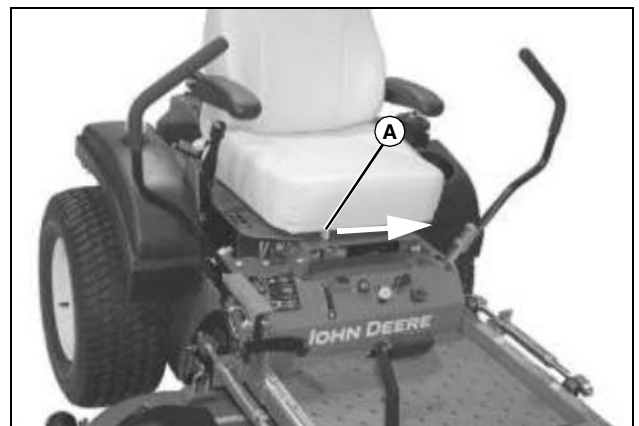

MX18400

2. Push and hold the seat adjustment lever (A) toward the middle of the seat.
3. Slide forward or backward to desired position.
4. Release lever.

OPERATING

Adjusting Mower Deck Cutting Height

CAUTION: Avoid injury! Before adjusting cutting height, stop engine and lock the park brake.

Cutting height can be adjusted from approximately 38 to 127 mm (1-1/2 to 5 in.). Each hole adjusts the height-of-cut (HOC) in approximately 6 mm (1/4 in.) increments.

The deck can also be raised and locked in a transport position, to provide maximum ground clearance when moving the machine from one area to another.

1. Park machine safely. (See Parking Safely in the SAFETY section.)

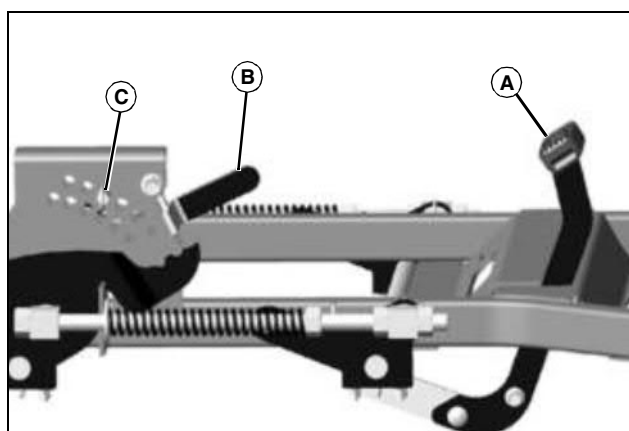

2. Depress the mower deck lift/lower pedal (A) until the transport position lock lever (B) engages.
3. Position the HOC adjustment pin (C) in the proper hole for the desired height-of-cut.
4. Depress the mower deck lift/lower pedal (A) and release the transport position lock lever (B).

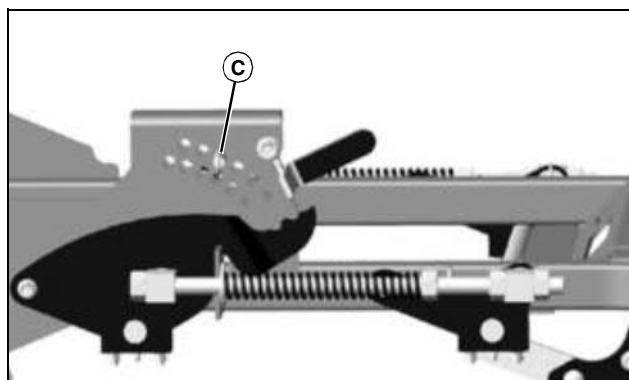

5. Lower the mower deck until it rests against the HOC adjustment pin (C).

Leveling Mower Deck

CAUTION: Avoid injury! Rotating blades are dangerous. Before adjusting or servicing mower:

- Disconnect spark plug wire(s) to prevent engine from starting accidentally.
- Always wear gloves when handling mower blades or working near blades.

NOTE: Mower deck anti-scalp wheels should not contact the ground.

1. Park machine safely. (See Parking Safely in the SAFETY section.)
2. Inflate tires to the correct pressure.
3. Raise the mower deck to the transport position.
4. Inspect mower blades for:
 - Blade sharpness.
 - Blade damage.
 - Bent blades.

Checking Level (Side-to-Side)

NOTE: Mower deck anti-scalp wheels should not contact the ground.

1. Lower deck to the 76 mm (3 in.) cutting height position.
2. Position left mower blade in the sideways (left to right) position.

NOTE: Use a short ruler or a leveling gauge (Part No. AM130907) to check the mower blade level.

3. Measure from outside blade tip to the ground.

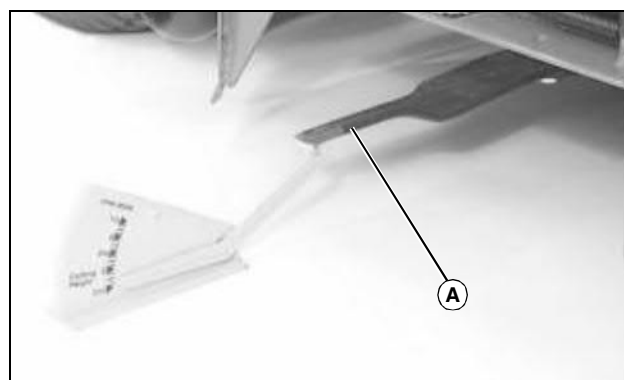

Picture Note: Discharge chute raised for photo clarity.

4. Position right mower blade (A) (discharge side) in the side-to-side position.



Suggest:

If the above button click is invalid.

Please download this document

first, and then click the above link

to download the complete manual.

Thank you so much for reading

OPERATING

5. Measure from outside blade tip to the ground.
 - The difference between both measurements should be no greater than 3 mm (1/8 in.).
6. If side-to-side level is not within the given tolerance, an adjustment is necessary.

Adjusting Level (Side-to-Side)

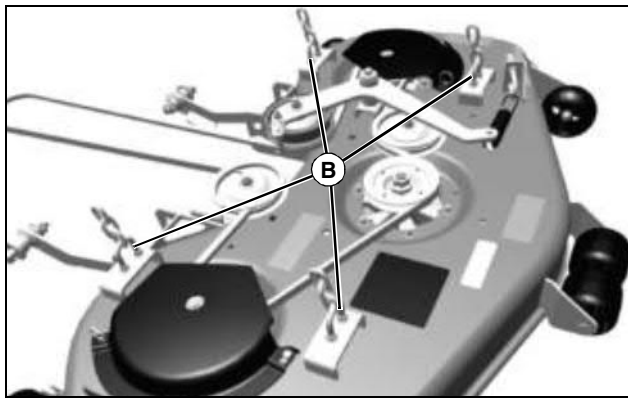

MX18453

1. Adjust the four chain U-bolts (B) (two on each side of the deck) until deck is within 3 mm (1/8 in.) of level from side to side.

Checking Level (Front-to-Rear)

1. Lower mower deck to the 76 mm (3 in.) cutting height position.
2. Position right mower blade (discharge side) in the straight forward (front-to-rear) position.
3. Measure from the right front blade tip to the ground.
4. Turn blade 180° and measure from right rear blade tip to the ground.

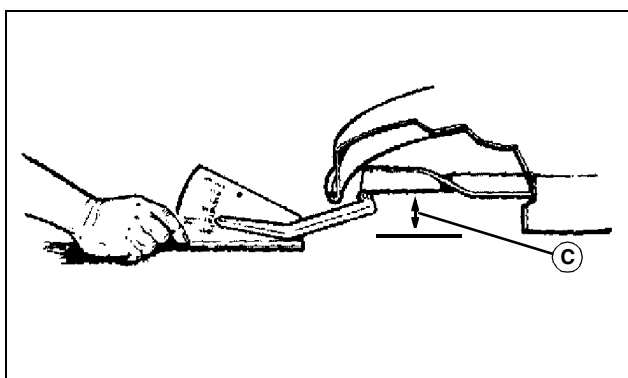

M40137

- The height (C) of the rear blade tip should be between 3-6 mm (1/8-1/4 in.) higher than the front blade tip.
5. If the front-to-rear level is not within the given tolerance, an adjustment is necessary.

Adjusting Level (Front-to-Rear)

IMPORTANT: Avoid damage! Adjust the left and right deck lift assist rods equally.

NOTE: Adjust side-to-side mower level before adjusting front-to-rear level.

Adjust both sides of the mower deck equally.

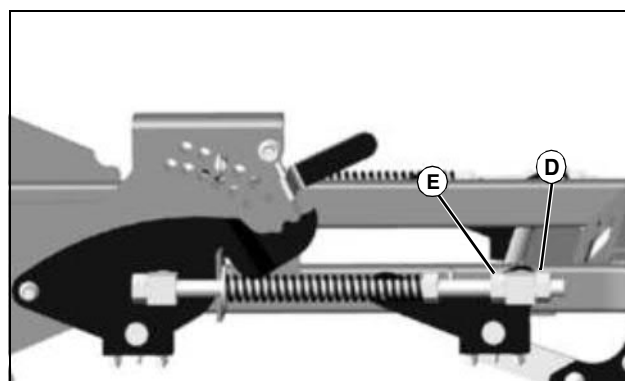

MX18449

1. Loosen jam nut (D) on each deck lift assist rod.
2. While positioned in front of the machine, adjust mower level:
 - Turn hex nut (E) clockwise to lower front of mower deck.
 - Turn hex nut (E) counterclockwise to raise front of mower deck.
3. Verify that the adjustment on right and left sides is equal.
4. Tighten jam nuts.
5. Check front-to-rear mower level.

Checking and Adjusting Cutting Height

CAUTION: Avoid injury! Rotating blades are dangerous. Before adjusting or servicing mower:

- Disconnect spark plug wire(s) to prevent engine from starting accidentally.
- Always wear gloves when handling mower blades or working near blades.

Checking Overall Cutting Height

1. Lower mower deck to the 76 mm (3 in.) cutting height.
2. Position right mower blade (discharge side) in the front-to-rear position.

<https://www.ebooklibonline.com>

Hello dear friend!

Thank you very much for reading.

Enter the link into your browser.

The full manual is available for immediate download.

<https://www.ebooklibonline.com>