

JOHN DEERE
WORLDWIDE COMMERCIAL & CONSUMER
EQUIPMENT DIVISION

Mini-Frame Z-Trak®
717 and 727

OMTCU15693 B2

OPERATOR'S MANUAL



JOHN DEERE

⚠ WARNING: The Engine Exhaust from this product contains chemicals known to the State of California to cause cancer, birth defects or other reproductive harm.

California Proposition 65 Warning

North American Version
Litho in U.S.A.

INTRODUCTION

Thank You for Purchasing a John Deere Product

We appreciate having you as a customer and wish you many years of safe and satisfied use of your machine.

Using Your Operator's Manual

This manual is an important part of your machine and should remain with the machine when you sell it.

Reading your operator's manual will help you and others avoid personal injury or damage to the machine. Information given in this manual will provide the operator with the safest and most effective use of the machine. Knowing how to operate this machine safely and correctly will allow you to train others who may operate this machine.

If you have an attachment, use the safety and operating information in the attachment operator's manual along with the machine operator's manual to operate the attachment safely and correctly.

This manual and safety signs on your machine may also be available in other languages (see your John Deere dealer to order).

Sections in your operator's manual are placed in a specific order to help you understand all the safety messages and learn the controls so you can operate this machine safely. You can also use this manual to answer any specific operating or servicing questions. A convenient index located at the end of this book will help you to find needed information quickly.

The machine shown in this manual may differ slightly from your machine, but will be similar enough to help you understand our instructions.

RIGHT-HAND and LEFT-HAND sides are determined by facing in the direction the machine will travel when going forward. When you see a broken line arrow (----->), the item referred to is hidden from view.

Before delivering this machine, your dealer performed a predelivery inspection to ensure best performance.

Special Messages

Your manual contains special messages to bring attention to potential safety concerns, machine damage as well as helpful operating and servicing information. Please read all the information carefully to avoid injury and machine damage.



CAUTION: Avoid injury! This symbol and text highlight potential hazards or death to the operator or bystanders that may occur if the hazards or procedures are ignored.

IMPORTANT: Avoid damage! This text is used to tell the operator of actions or conditions that might result in damage to the machine.

NOTE: General information is given throughout the manual that may help the operator in the operation or service of the machine.

PRODUCT IDENTIFICATION

Record Identification Numbers

Mini-Mount Z-Trak®

717 and 727 PIN (010001-)

If you need to contact an Authorized Service Center for information on servicing, always provide the product model and serial number.

You will need to locate the model and serial number for the machine and for the engine of your machine and record the information in the spaces provided below.

DATE OF PURCHASE:

DEALER NAME:

DEALER PHONE:



MX13145

PRODUCT IDENTIFICATION NUMBER (A):

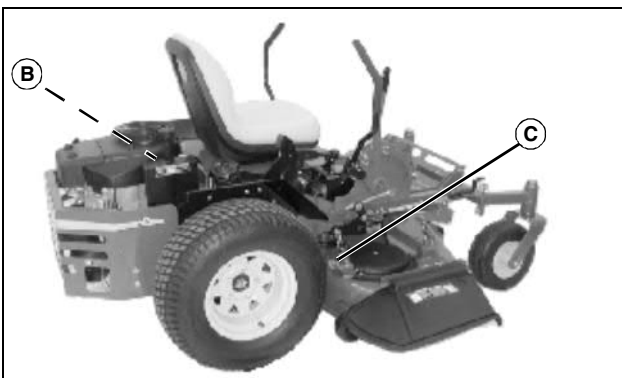

MX13144

ENGINE SERIAL NUMBER (B):

MOWER DECK SERIAL NUMBER (C):

<https://www.ebooklibonline.com>

Hello dear friend!

Thank you very much for reading.

Enter the link into your browser.

The full manual is available for immediate download.

<https://www.ebooklibonline.com>

TABLE OF CONTENTS

Safety	1
Operating	10
Replacement Parts	24
Service Intervals	25
Service Lubrication	26
Service Engine	28
Service Transmission.....	34
Service Steering & Brakes.....	38
Service Mower.....	40
Service Electrical.....	44
Service Miscellaneous.....	47
Troubleshooting	50
Storage	54
Assembly	56
Specifications	59
Warranty	62
Index.....	66

All information, illustrations and specifications in this manual are based on the latest information at the time of publication. The right is reserved to make changes at any time without notice.

COPYRIGHT© 2002
Deere & Co.
John Deere Worldwide Commercial and
Consumer Equipment Division
All rights reserved
Previous Editions
COPYRIGHT©

OMTCU15693 B2 - English

SAFETY

Understanding The Machine Safety Labels



Safety Alert Symbol

The machine safety labels shown in this section are placed in important areas on your machine to draw attention to potential safety hazards.

On your machine safety labels, the words DANGER, WARNING, and CAUTION are used with this safety-alert symbol. DANGER identifies the most serious hazards.

The operator's manual also explains any potential safety hazards whenever necessary in special safety messages that are identified with the word, CAUTION, and the safety-alert symbol.

DANGER

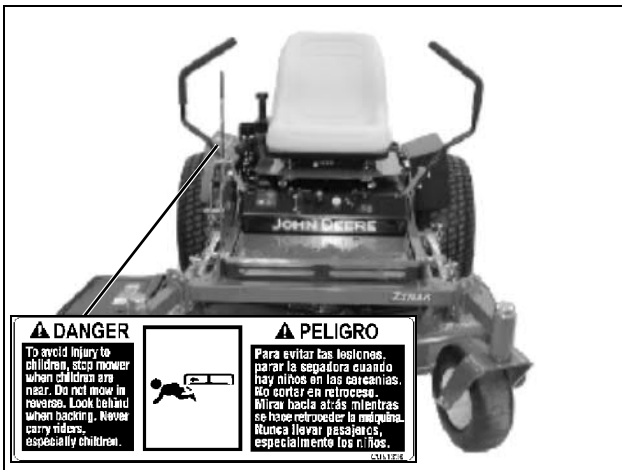

TCU51336 MX13121

To avoid injury to children, stop mower when children are near. Do not mow in reverse. Look behind when backing. Never carry riders, especially children.

DANGER

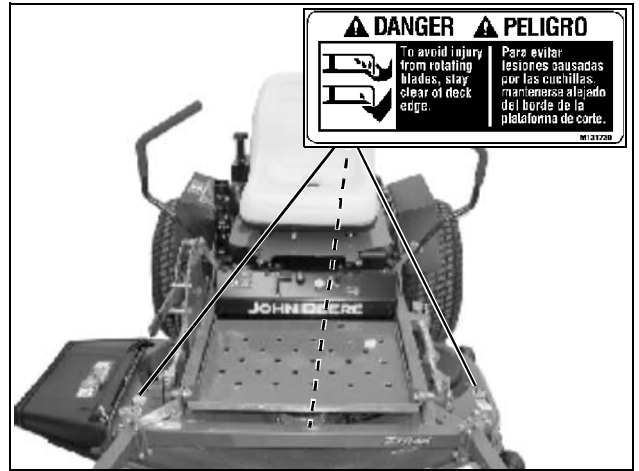

M131739 MX13110

To avoid injury from rotating blades, stay clear of deck edge.

DANGER

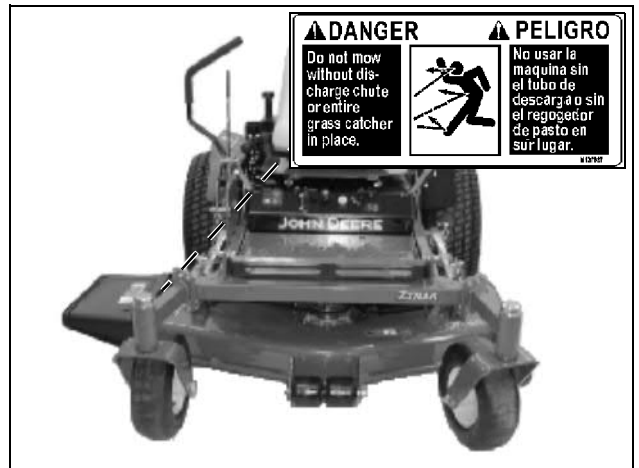

M137637 MX13121

Do not mow without discharge chute or entire grass catcher in place.

SAFETY

DANGER



M131748 MX13121

To avoid injury from rotating blades and thrown objects, stay clear of deck edge and keep others away. Do not mow without discharge chute or entire grass catcher in place.

POISON: CAUSES SEVERE BURNS

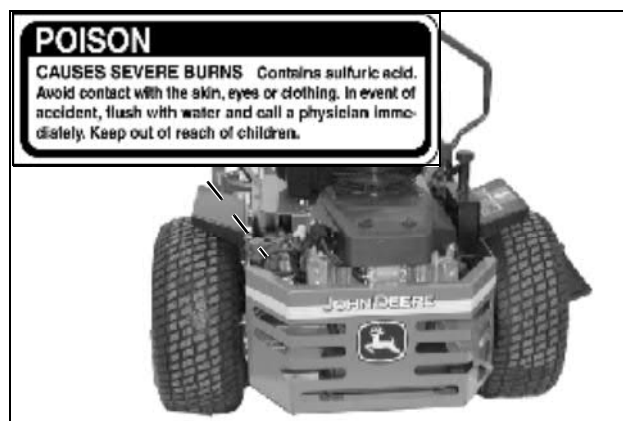

TCU14855 MX13145

- Contains sulfuric acid. Avoid contact with the skin, eyes or clothing. In event of accident, flush with water and call a physician immediately. Keep out of reach of children.

DANGER: EXPLOSIVE GASES

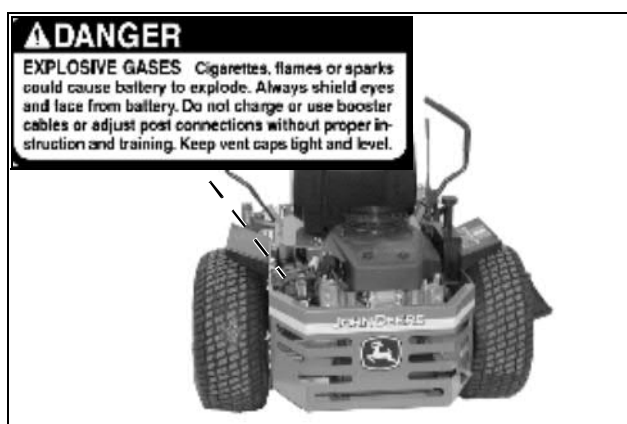

TCU14855 MX13145

- Cigarettes, flames or sparks could cause battery to explode. Always shield eyes and face from battery. Do not charge or use booster cables or adjust post connections without proper instruction and training. Keep vent caps tight and level.

WARNING



M134406 MX13144

Hot surface.

SAFETY

WARNING



TCU15907

To avoid injury from tipover, drive across slopes, not up and down. If machine stops going uphill, stop blades and back down slowly.

WARNING

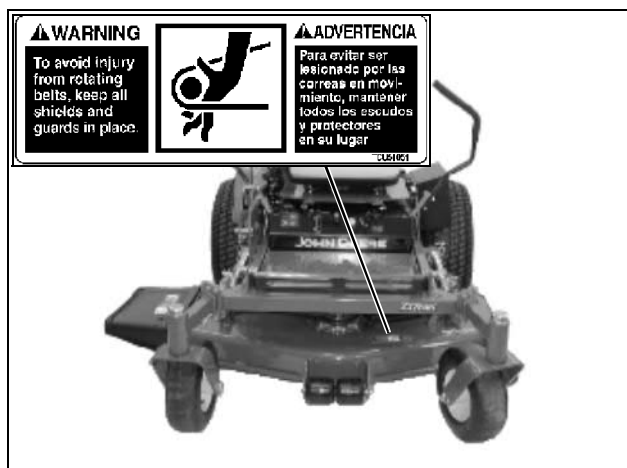

TCU51051 MX13121

To avoid injury from rotating belts, keep all shields and guards in place.

CAUTION: HELP AVOID INJURY

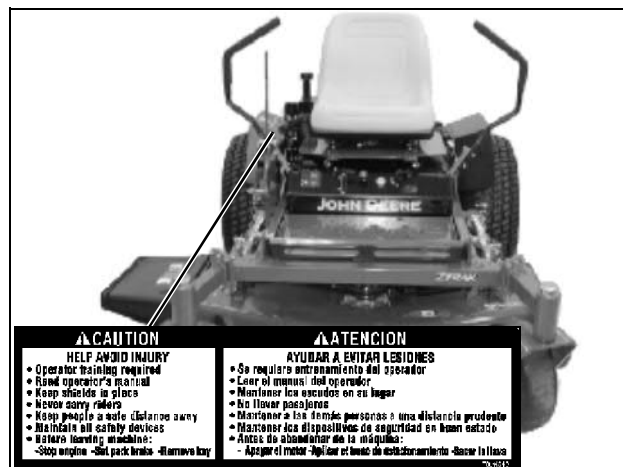

TCU14840 MX13121

- Operator training required
- Read operator's manual
- Keep shields in place
- Never carry riders
- Keep people a safe distance away
- Maintain all safety devices
- Before leaving machine:
 - Stop engine
 - Set park brake
 - Remove key

Emission Control System Certification Label

NOTE: Tampering with emission controls and components by unauthorized personnel may result in severe fines or penalties. Emission controls and components can only be adjusted by EPA and/or CARB authorized service centers. Contact your John Deere Commercial and Consumer Equipment Retailer concerning emission controls and component questions.

The presence of an emissions label signifies that the engine has been certified with the United States Environmental Protection Agency (EPA) and/or California Air Resources Board (CARB).

The emissions warranty applies only to those engines marketed by John Deere that have been certified by the EPA and/or CARB; and used in the United States and Canada in off-road mobile equipment.

SAFETY

Emission Compliance Period

If your engine has the emission compliance category listed on the emission control system certification or air index label, this indicates the number of operating hours for which the engine has been certified to meet EPA and/or CARB emission requirements. The following table provides the engine compliance period in hours associated with the category found on the certification label.

Agency	Category	Hours
EPA	C	250
EPA	B	500
EPA	A	1000
CARB	Moderate	125
CARB	Intermediate	250
CARB	Extended	500

Certification

This model has been tested and evaluated by the manufacturer and conforms to all applicable rotary mower requirements of ANSI B-71.4 American National Standard for commercial turf care equipment safety specification.

Operator Training Required

- The owner of the machine is responsible for training the users and mechanics of the machine.
- The owner/user can prevent and is responsible for accidents or injuries occurring to themselves, other people, or property.
- Do not allow operation or service of the machine by untrained adults.
- Do not let children operate the machine. Local regulations may restrict the age of the operator.
- Read the operator's manual and study the safety and operation sections before operating the machine.
- If the operator of the machine cannot read or understand this manual, it is the machine's owner responsibility to explain this material to the operator. This publication is available in other languages.
- Operate the machine in an open, unobstructed area under the direction of an experienced operator.
- Learn the use of all controls.
- Operator experience is required to learn the moving, stopping, turning and other operating characteristics of the

machine.

Operating Safely

- Inspect machine before you operate. Be sure hardware is tight. Repair or replace damaged, badly worn, or missing parts. Be sure guards and shields are in good condition and fastened in place. Make any necessary adjustments before you operate.
- Do not operate mower without discharge chute or entire grass catcher in place.
- Check before each use that operator presence controls are functioning correctly. Test safety systems. Do not operate unless they are functioning correctly.
- Do not operate machine if you are under the influence of drugs or alcohol.
- Do not change the engine governor setting or overspeed the engine.
- Always wear seat belt if machine has a standard ROPS or a folding ROPS in the upright position.
- Check brake action before you operate. Adjust or service brakes as necessary.
- Stop machine if anyone enters the area.
- Never raise mower decks when blades are running.
- If you hit an object, stop and inspect the machine. Make repairs before you operate. Keep machine and attachments properly maintained and in good working order.
- Do not leave machine unattended when it is running.
- Only operate during daylight or with good artificial light.
- Slow down and be careful of traffic when operating near or crossing roadways. Stop blades before crossing roads or sidewalks. Use care when approaching blind corners, shrubs, trees, or other objects that may obscure vision.
- Be aware of the mower discharge direction and make sure that no one is in the path of the discharge direction.
- Use only accessories and attachments approved by the manufacturer of the machine.
- Do not wear radio or music headphones. Safe service and operation require your full attention.

SAFETY

Checking Mowing Area

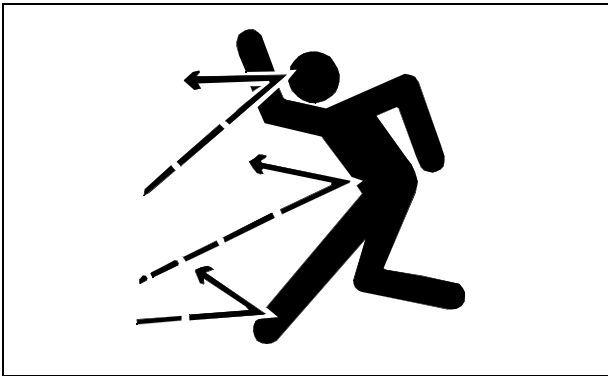

MIF

- Clear mowing area of objects that might be thrown. Keep people and pets out of mowing area.
- Study mowing area. Set up a safe mowing pattern. Do not mow where traction or stability is doubtful.
- Test drive area with mower lowered but not running. Slow down when you travel over rough ground.

Parking Safely

1. Stop machine on a level surface, not on a slope.
2. Move motion control levers out to the neutral lock position.
3. Disengage mower blades.
4. Lower attachments to the ground.
5. Lock the park brake.
6. Stop the engine.
7. Remove the key.
8. Wait for engine and all moving parts to stop before you leave the operator's seat.
9. Close fuel shut-off valve, if your machine is equipped.
10. Disconnect the negative battery cable or remove the spark plug wire (for gasoline engines) before servicing the machine.

Rotating Blades are Dangerous

HELP PREVENT SERIOUS OR FATAL ACCIDENTS:

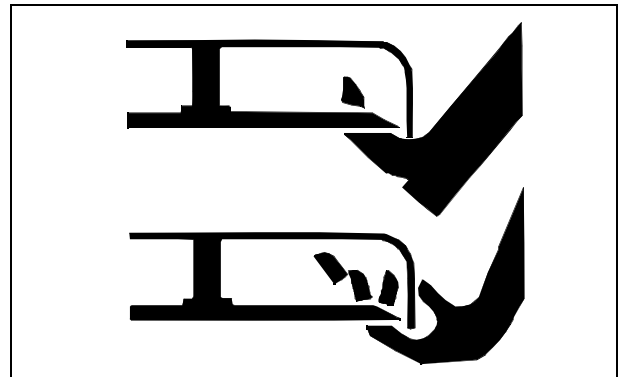

MIF

- Rotating blades can cut off arms and legs, and throw objects. Failure to observe safety instructions could result in serious injury or death.
- Keep hands, feet and clothing away from mower deck when engine is running.
- Be alert at all times, drive forward carefully. People, especially children can move quickly into the mowing area before you know it.
- Before backing up, stop mower blades or attachments and look down and behind the machine carefully, especially for children.
- Do not mow in reverse.
- Shut off blades when you are not mowing.
- Do not operate machine if you are under the influence of drugs or alcohol.
- Park machine safely before leaving the operator's station for any reason including emptying the catchers or unclogging the chute.

PROTECT CHILDREN:

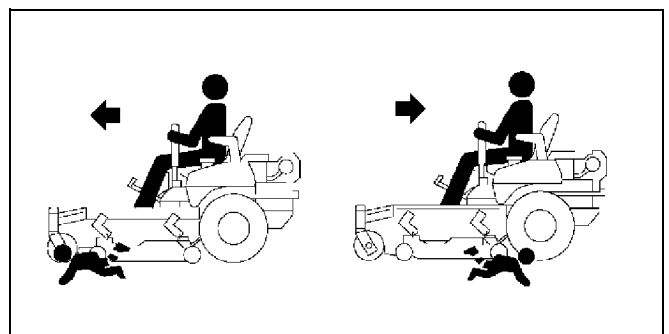

MIF

- Tragic accidents can occur if the operator is not alert to the presence of children. Keep children out of the mowing area and under the watchful care of another responsible adult.

SAFETY

- Never assume that children will remain where you last saw them. Children are attracted to mowing activity, stay alert to the presence of children.
- Keep children indoors when you are mowing. Turn the machine off if a child enters the mowing area.
- Use extra care when you come to blind corners, shrubs, trees, or other objects that may block your vision.
- Do not carry or let children ride on any attachment or machine even with the blades off. Do not tow children in a cart or trailer.

Avoid Tipping

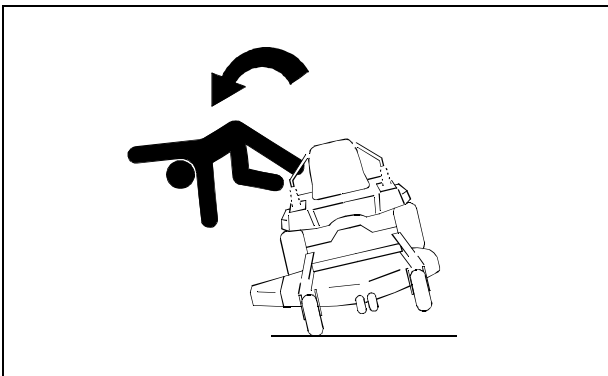

MIF

- Slopes are a major factor related to loss-of-control and tip-over accidents, which can result in severe injury or death.
- Do not drive where machine could slip or tip.
- Stay alert for holes and other hidden hazards in the terrain.
- Keep away from drop-offs, ditches, and embankments.
- Slow down before you make a sharp turn or operate on a slope.
- Transport machine with deck lowered to improve stability.
- Drive machine very slowly and avoid quick stops when attachment is removed.
- Drive across a hill, not up and down. Be careful when you change direction on a slope. If necessary, turn slowly and in the downhill direction.
- Operating machine when grass is wet can cause reduced traction and sliding.

Keep Riders Off

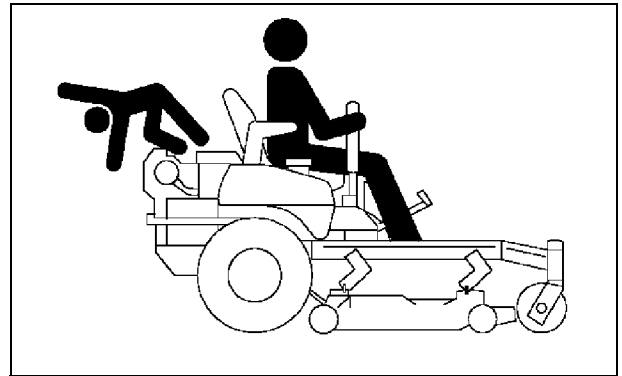

MIF

- Only allow the operator on the machine. Keep riders off.
- Riders on the machine or attachment may be struck by foreign objects or thrown off the machine causing serious injury.
- Riders obstruct the operator's view resulting in the machine being operated in an unsafe manner.

Checking Wheel Bolts

- A serious accident could occur causing serious injury if wheel bolts are not tight.
- Check wheel bolt tightness often during the first 100 hours of operation.
- Wheel hardware must be tightened to specified torque using the proper procedure anytime it is loosened.

Wear Appropriate Clothing



MIF

- Wear close fitting clothing and safety equipment appropriate for the job.
- Always wear safety goggles, or safety glasses with side shields, and a hard hat when operating the mower.

SAFETY

- Wear a suitable protective device such as earplugs. Loud noise can cause impairment or loss of hearing.
- Do not wear radio or music headphones. Safe service and operation requires your full attention.

Practice Safe Maintenance



MIF

- Never allow untrained personnel to service machine.
- Understand service procedure before doing work. Keep area clean and dry.
- Never lubricate, service, or adjust machine while it is moving. Keep safety devices in place and in working condition. Keep hardware tight.
- Keep hands, feet, clothing, jewelry, and long hair away from any moving parts, to prevent them from getting caught.
- Lower attachments to the ground before servicing machine. Disengage all power and stop the engine. Lock park brake and remove the key. Let machine cool.
- Disconnect battery or remove spark plug wire before making any repairs.
- Before servicing the machine, carefully release pressure from any components with stored energy, such as hydraulic components.
- Keep all nuts and bolts tightened, especially blade attachment bolts.
- Securely support any machine elements that must be raised for service work.
- Never run engine unless park brake is locked.
- Keep all parts in good condition and properly installed. Fix damage immediately. Replace worn or broken parts. Replace all worn or damaged safety and instruction decals.
- To prevent fires, remove any buildup of grease, oil, or debris from the machine, especially the engine compartment.
- Charge batteries in an open, well-ventilated area, away

- from sparks. Unplug battery charger before connecting or disconnecting from the battery. Use insulated tools.
- Do not modify machine or safety devices. Unauthorized modifications may impair its function and safety.

Driving Safely on Public Roads

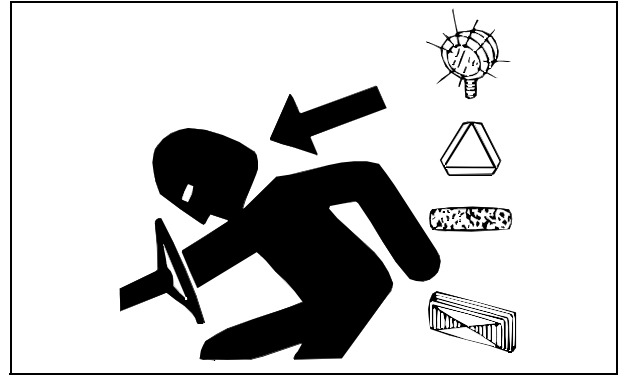

MIF

- Use safety lights and devices. Slow moving machines when driven on public roads are hard to see, especially at night.
- Whenever driving on public roads, use flashing warning lights and turn signals according to local regulations. Extra flashing warning lights may need to be installed.

Avoid High Pressure Fluids



MIF

- Hydraulic hoses and lines can fail due to physical damage, kinks, age, and exposure. Check hoses and lines regularly. Replace damaged hoses and lines.
- Hydraulic fluid connections can loosen due to physical damage and vibration. Check connections regularly. Tighten loose connections.
- Escaping fluid under pressure can penetrate the skin causing serious injury. Avoid the hazard by relieving pressure before disconnecting hydraulic or other lines.

SAFETY

Tighten all connections before applying pressure.

- Search for leaks with a piece of cardboard. Protect hands and body from high pressure fluids.
- If an accident occurs, see a doctor immediately. Any fluid injected into the skin must be surgically removed within a few hours or gangrene may result. Doctors unfamiliar with this type of injury should reference a knowledgeable medical source. Such information is available from Deere & Company Medical Department in Moline, Illinois, U.S.A. Information may be obtained in the United States and Canada only by calling 1-800-822-8262.

Prevent Fires

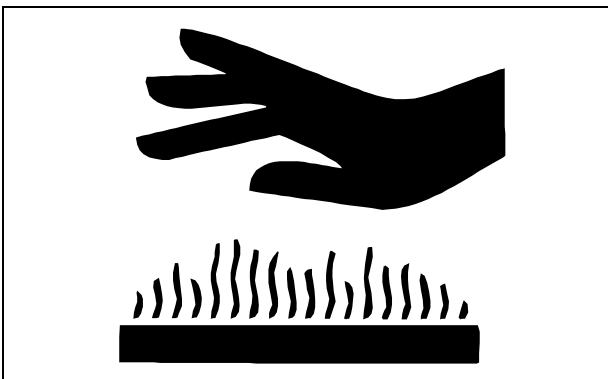

- Never remove fuel cap, or add fuel with engine running or hot. Allow engine to cool for several minutes.
- Never store equipment with fuel in the tank inside a building where fumes may reach an open flame or spark.
- Allow engine to cool before storing in any enclosure.
- To reduce fire hazard, keep engine free of grass, leaves, or excessive grease.

Tire Safety



Explosive separation of a tire and rim parts can cause serious injury or death:

- Do not attempt to mount a tire without the proper equipment and experience to perform the job.
- Always maintain the correct tire pressure. Do not inflate the tires above the recommended pressure. Never weld or heat a wheel and tire assembly. The heat can cause an increase in air pressure resulting in a tire explosion. Welding can structurally weaken or deform the wheel.
- When inflating tires, use a clip-on chuck and extension hose long enough to allow you to stand to one side and NOT in front of or over the tire assembly.
- Check tires for low pressure, cuts, bubbles, damaged rims or missing lug bolts and nuts.

Handling Fuel Safely

Fuel and fuel vapors are highly flammable:

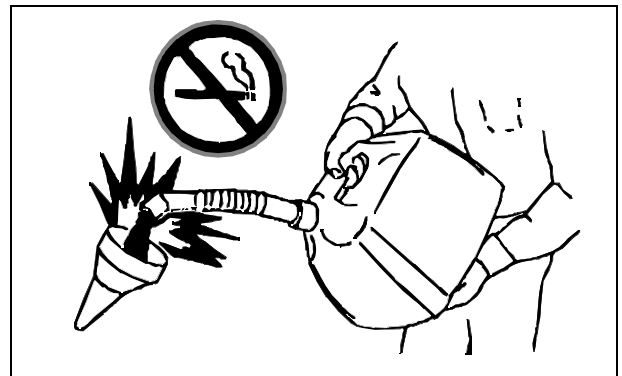

- Do not refuel machine while you smoke, when machine is near an open flame or sparks, or when engine is running. Stop engine and allow to cool before filling.
- Never remove the fuel cap or add fuel with the engine running.
- Never fill fuel tank or drain fuel from a machine in an enclosed area. Fill fuel tank outdoors.
- Prevent fires. Clean up spilled fuel immediately.
- Do not store fuel in can or machine with fuel in tank in a building where fumes may reach an open flame or spark.
- Prevent fire and explosion caused by static electric discharge. Use only non-metal, portable fuel containers approved by the Underwriter's Laboratory (U.L.) or the American Society for Testing & Materials (ASTM). If using a funnel, make sure it is plastic and has no screen or filter.

SAFETY



- Static electric discharge can ignite gasoline vapors in an ungrounded fuel container. Remove the fuel container from the bed of a vehicle or the trunk of a car and place on the ground away from the vehicle before filling. Keep nozzle in contact with container opening while filling.
- When practical, remove equipment from trailers or truck beds and refuel them on the ground. If this is not possible, use a portable, plastic fuel container to refuel equipment on a truck bed or trailer.
- For gasoline engines, do not use gas with methanol. Methanol is harmful to your health and to the environment.

Handling Waste Product and Chemicals

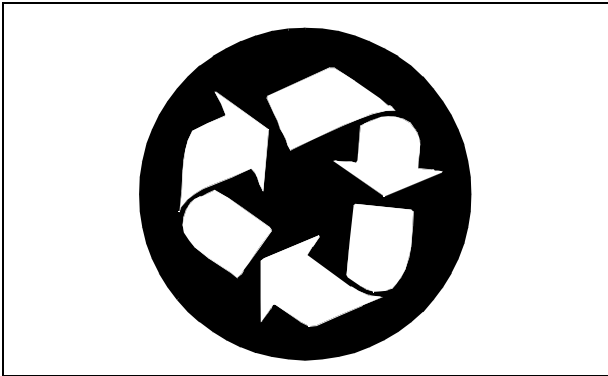

Waste products, such as, used oil, fuel, coolant, brake fluid, and batteries, can harm the environment and people:

- Do not use beverage containers for waste fluids - someone may drink from them.
- See your local Recycling Center or John Deere dealer to learn how to recycle or get rid of waste products.
- A Material Safety Data Sheet (MSDS) provides specific details on chemical products: physical and health hazards, safety procedures, and emergency response techniques. The seller of the chemical products used with your machine is responsible for providing the MSDS for that product.

OPERATING

Daily Operating Checklist

- Make sure all necessary guards and shields are safely and securely attached. Check for loose, missing, or damaged parts.
- Test park brake.
- Check battery electrolyte level.
- Test safety systems.
- Check engine oil level, hydraulic oil level and for oil leaks.
- Inspect all belts for damage.
- Check mower level.
- Adjust cutting height if necessary.
- Check tire pressure. Check tires for damage or cracking.
- Remove mower deck belt shields- inspect and clean grass and debris from belt area.
- Remove grass and debris from: Operator station foot plate, air intake screen, engine cooling fins, hydraulic pumps and pump mounting sub-frame.
- Check engine air filter.
- Check and adjust steering control linkages.

Avoid Damage to Plastic and Painted Surfaces

- Do not wipe plastic parts unless rinsed first.
- Insect repellent spray may damage plastic and painted surfaces. Do not spray insect repellent near machine.
- Be careful not to spill fuel on machine. Fuel may damage surface. Wipe up spilled fuel immediately.

Operator Station Controls

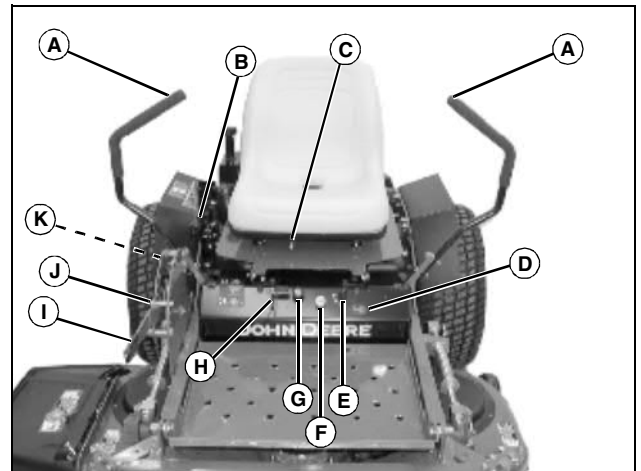

MX13110

- A - Motion Control Levers**
- B - Park Brake Lever**
- C - Seat Adjustment Lever**
- D - Hourmeter**
- E - Ignition Key Switch**
- F - PTO Knob**
- G - Choke**
- H - Throttle Lever**
- I - Mower Deck Lift/Lower Lever**
- J - Height-of-Cut (HOC) Adjustment Pin**
- K - Mower Deck Transport Position Lock Lever**

Miscellaneous Controls

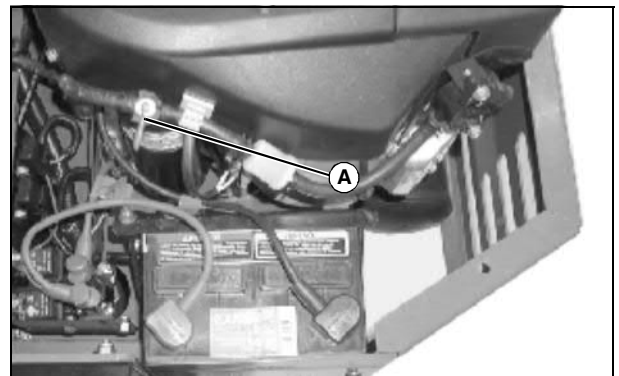

MX13111

- A - Fuel Shutoff Valve**

OPERATING

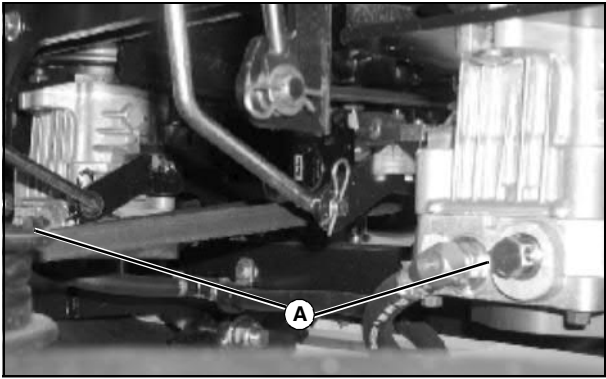

MX13124

A - Free-Wheeling Pump Release Valves

Mounting and Dismounting Machine Safely

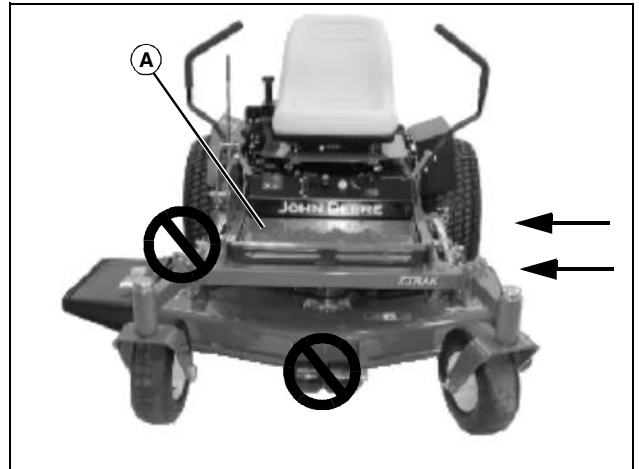

MX13121

Do not step on the mower deck when mounting and dismounting the machine. Mount the machine from the left side using the foot plate (A). Park machine safely (see Parking Safely in the Safety section) before dismounting.

Keep the foot plate clean.

Raising and Lowering Operator Seat



CAUTION: Avoid injury! The seat is heavy and can cause injury if it falls. When performing any service function under the operator seat, make sure the seat is tilted forward and rests against the hinge stops.

Raising the Seat

1. Park machine safely. (See Parking Safely in the Safety section.)

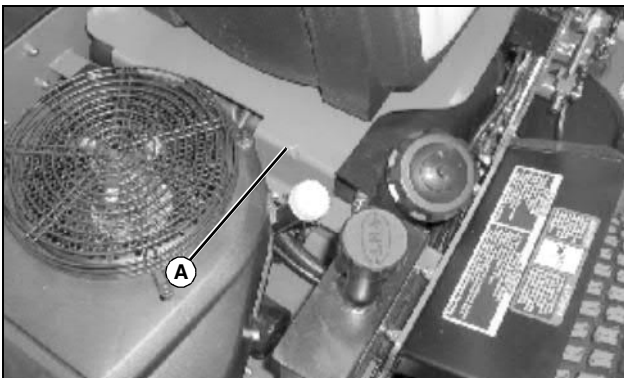

MX13108

2. Lift seat frame (A) and tilt forward until it rests against the hinge stops.

Lowering the Seat

1. Stand on the side of the machine.
2. Push operator seat back and slowly lower seat frame.

Adjusting Seat

1. Sit on operator seat.

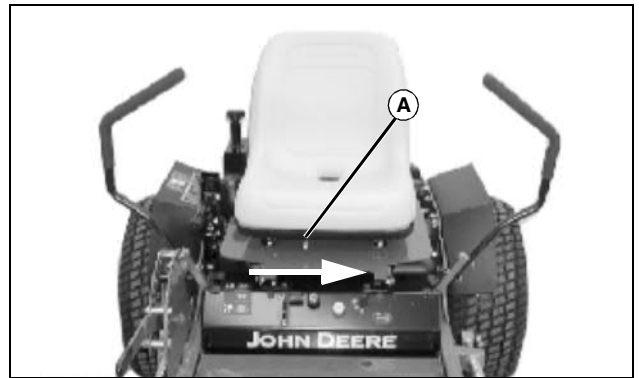

MX13110

2. Push and hold the seat adjustment lever (A) toward the middle of the seat.
3. Slide forward or backward to desired position.
4. Release lever.

OPERATING

Adjusting Mower Deck Cutting Height

CAUTION: Avoid injury! Before adjusting cutting height, stop engine and lock the park brake.

Cutting height can be adjusted from approximately 38–114 mm (1-1/2–4-1/2 in.). Each hole adjusts the height-of-cut (HOC) in approximately 12 mm (1/2 in.) increments.

The deck can also be raised and locked in a transport position, to provide maximum ground clearance when moving the machine from one area to another.

1. Park machine safely. (See Parking Safely in the Safety section.)

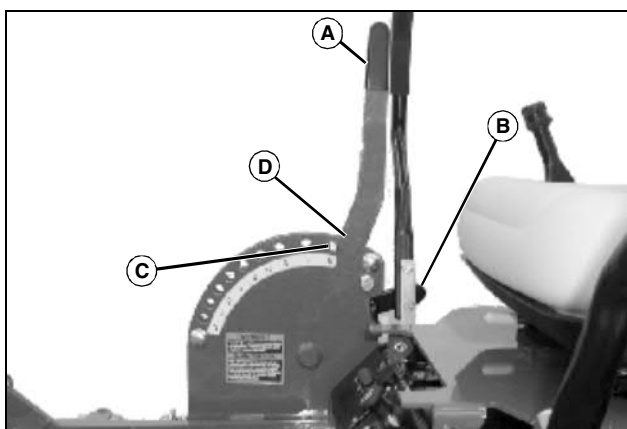

MX13149

2. Move the mower deck lift lever (A) to the transport position (D).
3. Position the HOC adjustment pin (C) in the proper hole for the desired height of cut.
4. Pull back and hold the mower deck lift lever (A) and release the transport position lock lever (B).

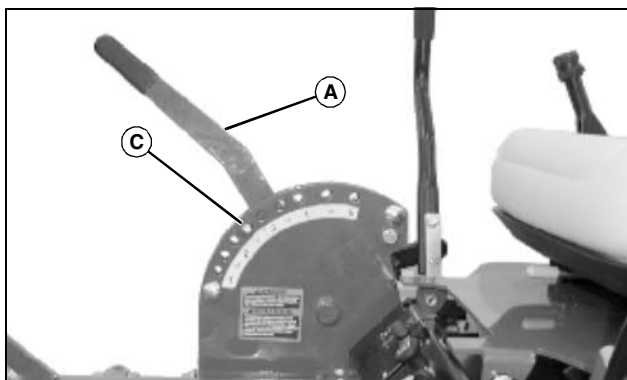

MX13155

5. Allow the mower deck lift lever (A) to rest against the HOC adjustment pin (C).

Leveling Mower Deck

CAUTION: Avoid injury! Rotating blades are dangerous. Before adjusting or servicing mower:

- Disconnect spark plug wire(s) to prevent engine from starting accidentally.
- Always wear gloves when handling mower blades or working near blades.

NOTE: Mower deck anti-scalp wheels should not contact the ground.

1. Park machine safely. (See Parking Safely in the Safety section.)
2. Inflate tires to the correct pressure.
3. Raise the mower deck lift lever to the transport position.
4. Inspect mower blades for:
 - Blade sharpness.
 - Blade damage.
 - Bent blades.

Checking Level (Side-to-Side)

NOTE: Mower deck anti-scalp wheels should not contact the ground.

1. Lower deck to the 76 mm (3 in.) cutting height position.
2. Position left mower blade in the sideways (left to right) position.

NOTE: Use a short ruler or a leveling gauge (Part No. AM130907) to check the mower blade level.

3. Measure from outside blade tip to the ground.

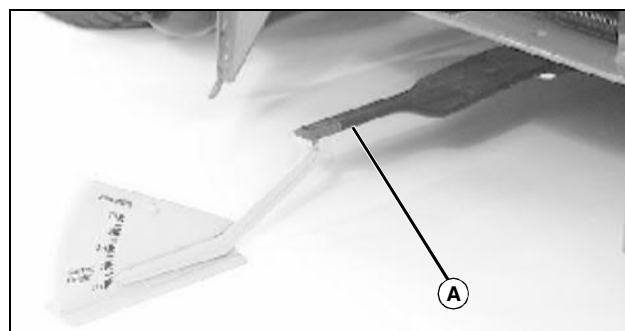

Mx10371

Picture Note: Discharge chute raised to illustrate photo clarity.

4. Position right mower blade (A) (discharge side) in the side-to-side position.
5. Measure from outside blade tip to the ground.

OPERATING

- The difference between both measurements should be no greater than 3 mm (1/8 in.).

6. If side-to-side level is not within the given tolerance, an adjustment is necessary.

Adjusting Level (Side-to-Side)

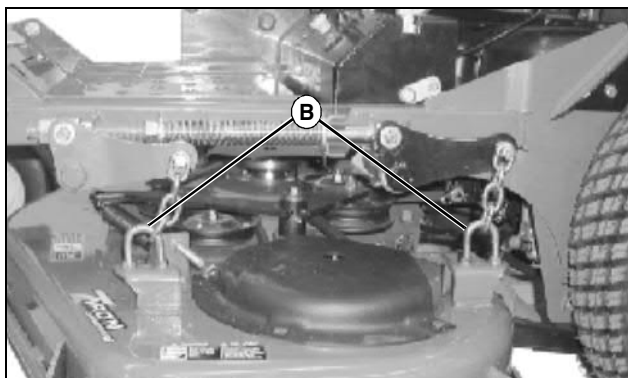

MX13127

1. Adjust four chain U-bolts (B) (two on each side of the deck) until the deck is within 3 mm (1/8 in.) of level from side to side.

Checking Level (Front-to-Rear)

1. Lower mower deck to the 76 mm (3 in.) cutting height position.
2. Position right mower blade (discharge side) in the straight forward (front-to-rear) position.
3. Measure from the right front blade tip to the ground.
4. Turn blade 180° and measure from right rear blade tip to the ground.

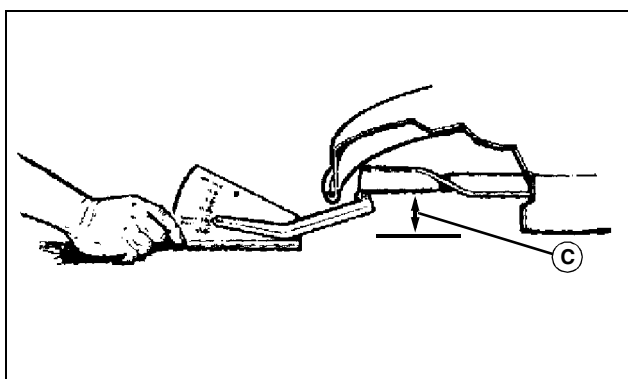

M40137

- The height (C) of the rear blade tip should be between 3–6 mm (1/8–1/4 in.) higher than the front blade tip.

5. If the front-to-rear level is not within the given tolerance, an adjustment is necessary.

Adjusting Level (Front-to-Rear)

IMPORTANT: Avoid damage! Adjust the left and right deck lift assist rods equally.

NOTE: Adjust side-to-side mower level before adjusting front-to-rear level.

Adjust both sides of the mower deck equally.

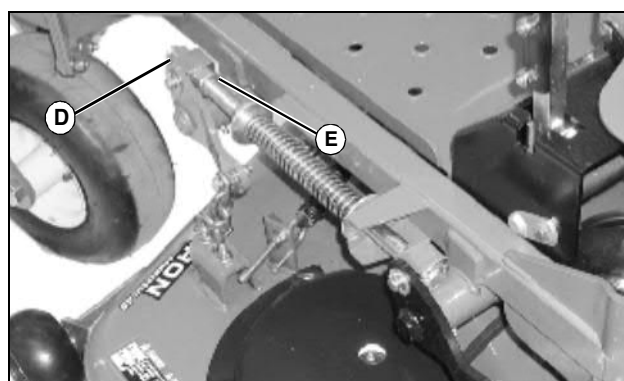

MX13129

1. Loosen jam nut (D) on each deck lift assist rod.
2. While positioned in front of the machine, adjust mower level:
 - Turn hex nut (E) clockwise to lower front of mower deck.
 - Turn hex nut (E) counterclockwise to raise front of mower deck.
3. Verify that the adjustment on right and left sides is equal.
4. Tighten jam nuts.
5. Check front-to-rear mower level.

Checking and Adjusting Cutting Height

CAUTION: Avoid injury! Rotating blades are dangerous. Before adjusting or servicing mower:

- Disconnect spark plug wire(s) to prevent engine from starting accidentally.
- Always wear gloves when handling mower blades or working near blades.

Checking Overall Cutting Height

1. Lower mower deck to the 76 mm (3 in.) cutting height.
2. Position right mower blade (discharge side) in the front-to-rear position.

OPERATING

3. Measure from the front of the blade tip to the ground.
4. If blade tip height is not within 73–79 mm (2-7/8 –3-1/8 in.), an adjustment is needed.

Adjusting Overall Cutting Height

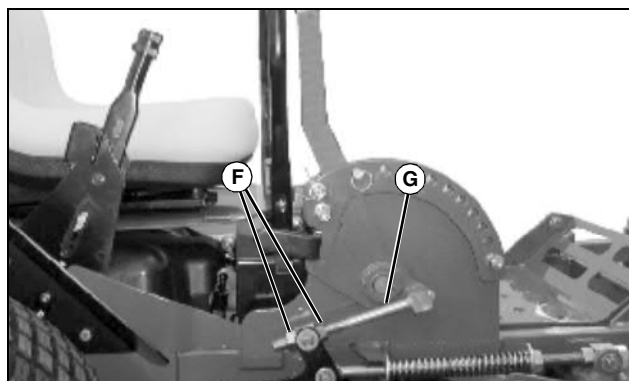

1. Adjust deck lift handle connecting rod (G) while viewing adjusting mechanism from rear of machine.
 - To lower deck, turn nuts (F) counter-clockwise to lengthen rod (G).
 - To raise deck, turn nuts (F) clockwise to shorten rod (G).
2. If there is no room for adjustment in the connecting rod, adjust the chain U-bolts.

NOTE: Adjust all four chain U-bolts equally. All four chains should be tight. Tighten the U-bolt of the loose chain to correct.

3. To increase the overall cutting height to 127 mm (5 in.), adjust all four chain U-bolts closer to the deck by 12.7 mm (1/2 in.).

Adjusting Deck Lift Spring Tension

NOTE: Deck lift spring tension is adjusted at the factory. If the effort required to raise or lower the mower deck is not satisfactory, an adjustment may be necessary.

Check Spring Tension

1. Park machine on a hard, level surface.
2. Stop engine and lock park brake.
3. Raise the mower deck lift lever to the transport position.

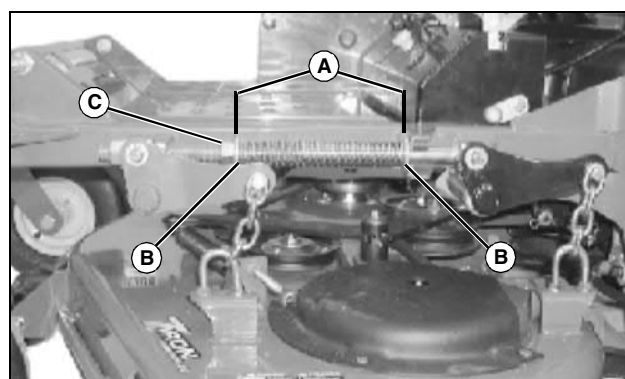

4. Measure distance (A) between the washers (B) on each deck lift spring assembly.

- The recommended factory setting is 21 cm (8-1/4 in.).

Adjust Spring Tension

NOTE: Both deck lift spring assemblies must be adjusted equally.

Do not over tension the deck lift springs. If the springs are compressed too tightly, the mower deck will float too freely.

Decrease deck lift spring tension if operating in rough terrain.

While positioned in front of the machine:

- Turn hex nut (C) clockwise to increase deck lift spring tension and reduce the effort to raise and lower the mower deck.
- Turn hex nut (C) counterclockwise to decrease deck lift spring tension and increase the effort to raise and lower the mower deck.

Adjusting Mower Deck Anti-Scalp Wheels



CAUTION: Avoid injury! Before adjusting anti-scalp wheels:

- Stop engine.
- Lock park brake.
- Remove key.
- Wait for all moving parts to stop.

NOTE: The flattest cut can be achieved by having all anti-scalp wheels adjusted off the ground. Check anti-scalp wheel adjustments each time the mower deck cutting height is changed.



Suggest:

If the above button click is invalid.

Please download this document

first, and then click the above link

to download the complete manual.

Thank you so much for reading

OPERATING

It is recommended that all anti-scalp wheels be kept off the ground to minimize scuffing.

1. Check machine tire pressure. Inflate tires to the correct pressure.
2. Adjust mower deck to desired cutting height.

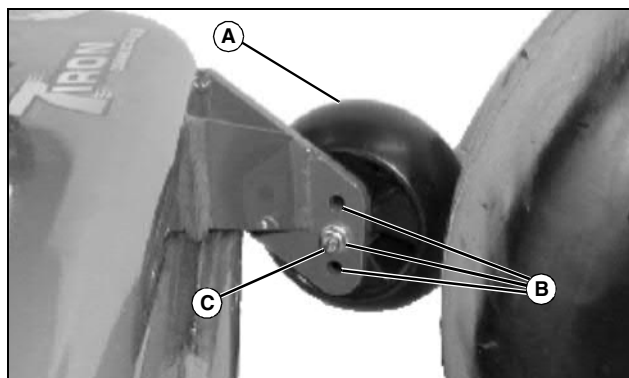

MX13133

3. Adjust anti-scalp wheel (A) to one of three positions (B). Remove hex bolt (C), nylock nut and washer.

- Adjust wheel up or down so it is approximately 6–13 mm (1/4–1/2 in.) above the mowing surface.

4. Install wheel with attaching hardware.
5. Adjust all wheels to the same height.

Testing Safety Systems



CAUTION: Avoid injury! Engine exhaust fumes contain carbon monoxide and can cause serious illness or death.

Move the vehicle to an outside area before running the engine.

Do not run an engine in an enclosed area without adequate ventilation.

- **Connect a pipe extension to the engine exhaust pipe to direct the exhaust fumes out of the area.**
- **Allow fresh outside air into the work area to clear the exhaust fumes out.**

Use the following checkout procedures to check for normal operation.

If there is a malfunction during one of these procedures, Do not operate machine. (See your John Deere dealer.)

Perform these tests in a clear open area. Keep bystanders away.

Testing PTO Switch

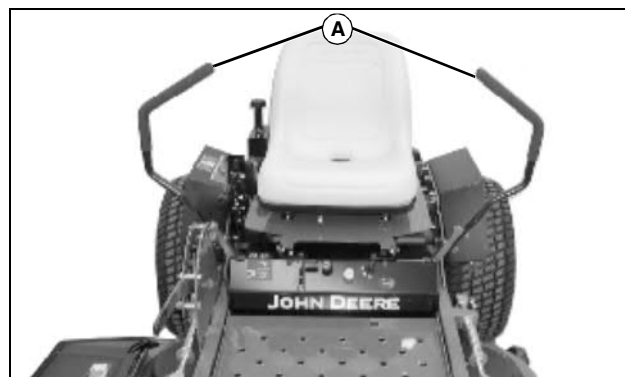

MX13110

1. Sit on the operator seat with the motion control levers (A) in the neutral lock position.
2. Lock the park brake.
3. Pull PTO knob up to engage.

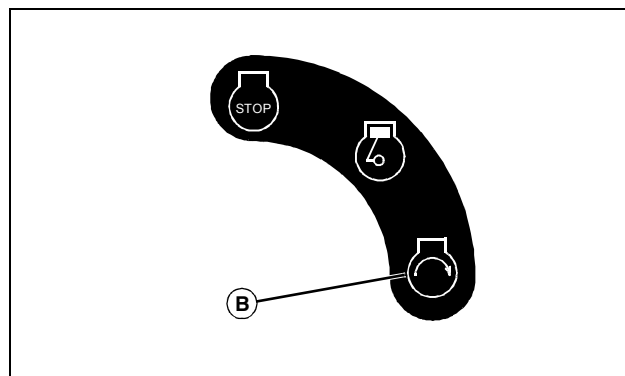

MIF

4. Turn key switch to the start position (B).

Result: The engine must not crank.

Testing Park Brake Switch

1. Sit on the operator seat with the motion control levers in the neutral lock position.
2. Push PTO knob down to disengage.
3. Unlock park brake.
4. Turn key switch to the start position.

Result: The engine must not crank.

<https://www.ebooklibonline.com>

Hello dear friend!

Thank you very much for reading.

Enter the link into your browser.

The full manual is available for immediate download.

<https://www.ebooklibonline.com>