

# **PTO TILLER for 4200-4500 Compact Utility Tractors Model 550**

Serial No. (010001 - )

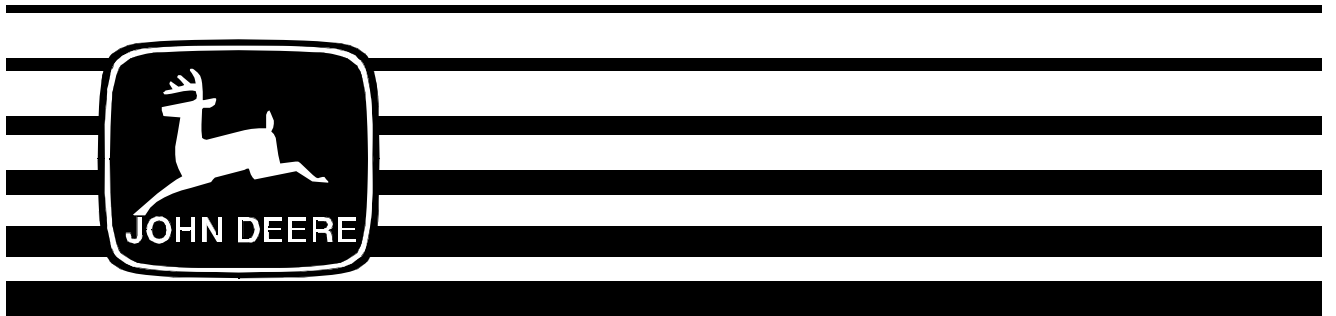

## **OPERATOR'S MANUAL**

**John Deere  
Worldwide Commercial And  
Consumer Equipment Division  
OMM137898 H8**

**North American Version  
Litho in U.S.A.  
English**

# INTRODUCTION

## THANK YOU for purchasing a John Deere product.

Read this manual and your vehicle manual thoroughly. Failure to do so could result in personal injury or equipment damage.

This manual should be considered a permanent part of your machine and should remain with the machine when you sell it.

Measurements in this manual are metric units and their U.S. customary equivalents. RIGHT-HAND and LEFT-HAND sides are determined by facing in the direction the machine will travel when going forward. When you see a broken line arrow (----->) it indicates the part it is pointing to is hidden.

Product warranty is provided as part of John Deere's support program for customers who operate and maintain their equipment as described in this manual. The product warranty is explained on the warranty certificate you received from your dealer.

Record identification numbers. Be sure to record all the numbers to help in tracing the machine if it is stolen. You also need to give these numbers to your dealer when you order parts.

### DATE OF PURCHASE:

\_\_\_\_\_  
DEALER NAME:

\_\_\_\_\_  
DEALER PHONE:

\_\_\_\_\_  
SERIAL NUMBER (A):

-----

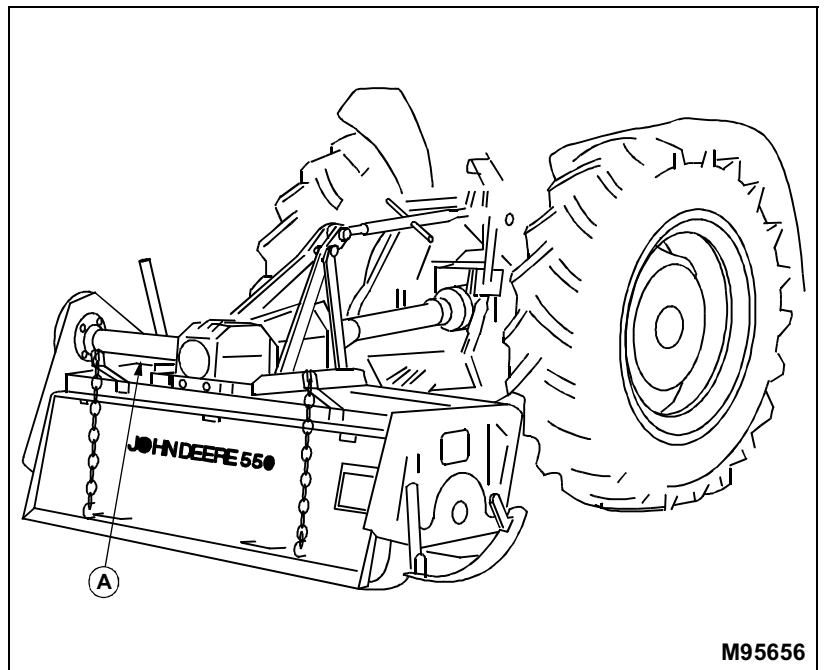
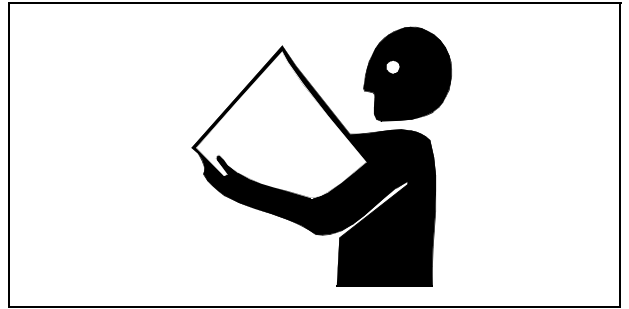

M95656

---

---

# TABLE OF CONTENTS

---

---

Safety Signs.....	1
Preparing Vehicle.....	3
Installing .....	5
Removing .....	9
Operating Machine .....	11
Replacement Parts .....	26
Service Machine Safely .....	27
Service .....	28
Troubleshooting .....	44
Storing Machine .....	45
Assembly .....	46
Specifications .....	56
Index .....	57
John Deere Service Literature .....	59

All information, illustrations and specifications in this manual are based on the latest information at the time of publication. The right is reserved to make changes at any time without notice.

COPYRIGHT© 1998  
Deere & Co.  
John Deere Worldwide Commercial and  
Consumer Equipment Division  
Horicon, WI  
All rights reserved

OMM137898 H8

**<https://www.ebooklibonline.com>**

Hello dear friend!

Thank you very much for reading.

Enter the link into your browser.

The full manual is available for immediate download.

**<https://www.ebooklibonline.com>**

# SAFETY SIGNS

## Safety-Alert Symbol

Read and recognize safety information. Be alert to the potential for personal injury when you see this safety-alert symbol.

On your machine safety labels, the words DANGER, WARNING, and CAUTION are used with this safety-alert symbol. DANGER identifies the most serious hazards. In this manual, the word CAUTION and this symbol call attention to safety messages.

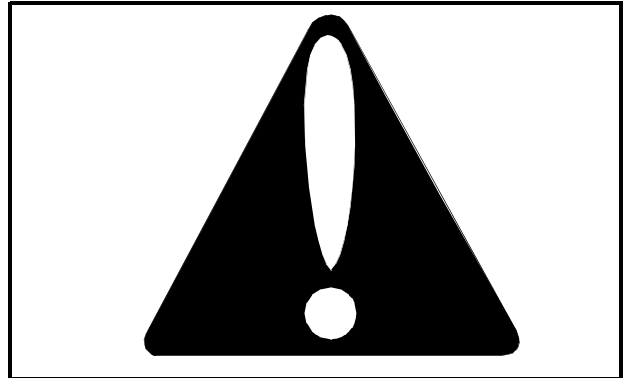

## Machine Safety Labels

### WARNING: AVOID INJURY FROM ROTATING KNIVES:

- Keep hands, feet and clothing away.

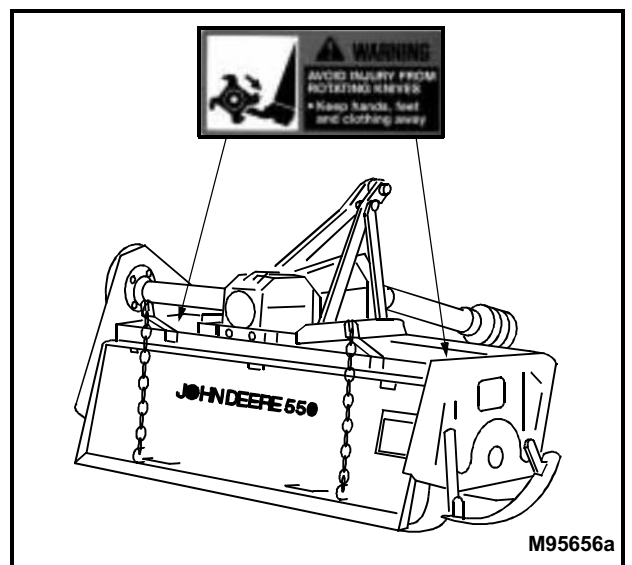

### WARNING: AVOID INJURY FROM PTO:

- Keep all shields in place.
- Keep hands, feet and clothing away.
- Operate only with 540 RPM.

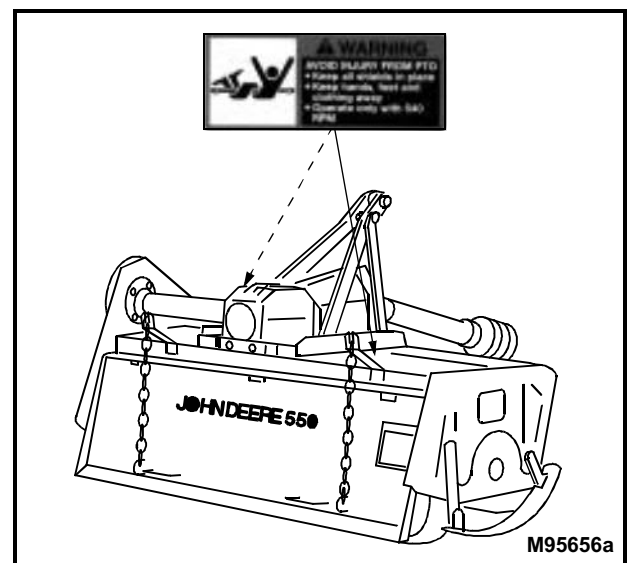

# SAFETY SIGNS

## CAUTION: AVOID INJURY

- Read Operator's Manual
- Ballast power unit per operator's manual
- Know location and function of controls
- Keep all shields in place
- Stay clear of power driven parts
- Never carry riders
- Keep people and pets a safe distance away from machine

## BEFORE DISMOUNTING OR SERVICING

- Shut off engine and remove key
- Lock brake for park
- Lower or block up machine

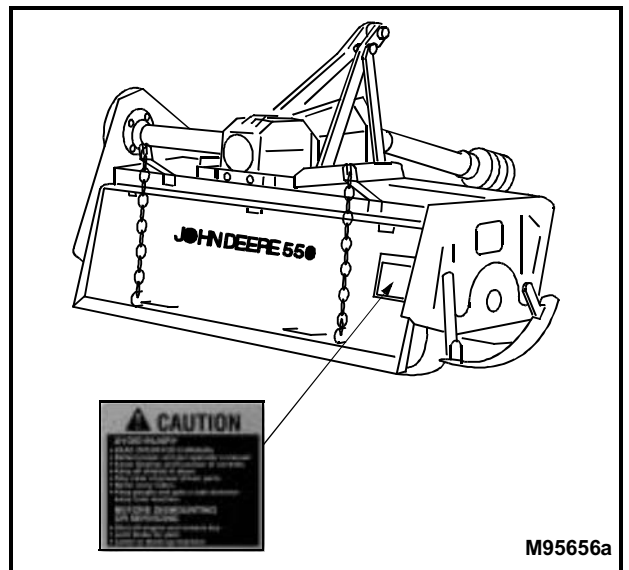

## DANGER: ROTATING DRIVELINE – CONTACT CAN CAUSE DEATH – KEEP AWAY! – DO NOT OPERATE WITHOUT:

- All driveline, tractor and equipment shields in place
- Drivelines securely attached at both ends
- Driveline shields that turn freely on driveline

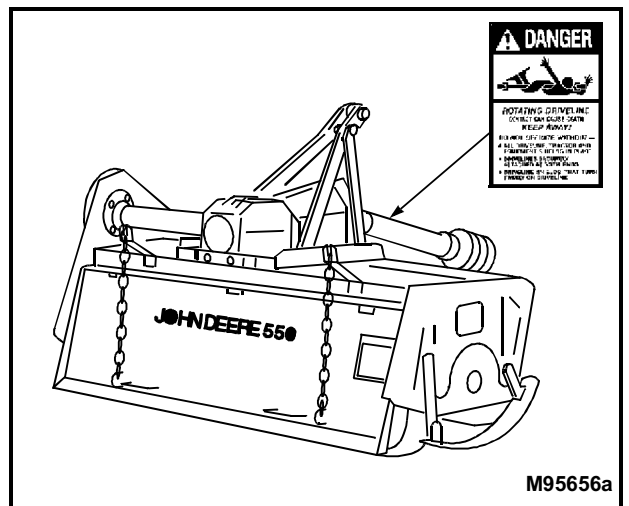

## DANGER: SHIELD MISSING DO NOT OPERATE

Picture Note: Separate telescoping driveshaft members to locate safety label. Label attached to outer profile tube.

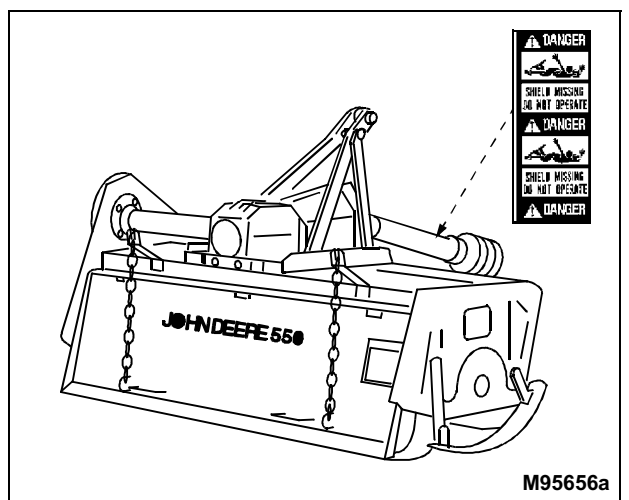

## PREPARING VEHICLE

---

### Ballast Requirements



**CAUTION:** Help prevent personal injury. Proper ballasting is required for safe operation of your tiller. Install the correct number of front weights to help maintain tractor steering control and stability.

**NOTE:** Ballasting requirements may be different with other tire options not shown. Refer to the tractor operator's manual for additional ballasting information.

Tiller Model	Tractor Model Series				Number of Suitcase Weights Required With R1 Bar Tires
	4200 — 4400		4500		
	2WD	MFWD	2WD	MFWD	
550	X				4
550		X			3
550			X		4
550				X	3

**NOTE:** Each standard John Deere suitcase weight weighs 32 kg. (70 lb.).

## PREPARING VEHICLE

---

### Preparing the Tractor

**IMPORTANT:** Refer to the tractor operator's manual for additional ballasting and tire pressure information.

#### Tractor Requirements

- A Category 1, 3-point hitch.
- A 540 rpm PTO.
- Refer to the tractor operator's manual for correct ballasting and tire pressure, depending on installed equipment.

The tiller models listed below can be mounted on the following John Deere (or similar) model series tractors:

**NOTE:** *The 550 tiller is not recommended for use on John Deere Model 4100 and 4600 series tractors.*

Tiller Model	Tractor Model Series			
	4200	4300	4400	4500
550	X	X	X	X

# INSTALLING

## Park Vehicle Safely

- Stop vehicle on a level surface, not on a slope.
- Disengage PTO.
- Engage the park brake.
- STOP the engine.
- Remove the key.
- Before you leave the operator's seat, wait for engine and all moving parts to STOP.

## Stay Clear Of Rotating Drivelines

Entanglement in rotating driveline can cause serious injury or death:

- Wear close fitting clothing.
- STOP the engine and be sure PTO driveline is stopped before getting near it.



## Installing Tiller On Tractor

**IMPORTANT: Check gearbox oil level before operating tiller.**

1. Remove quick-lock pins and drilled pins stored in tiller draft link brackets.
2. Back tractor into position and align draft links (A) with draft link brackets (B) on tiller using tractor rockshaft control lever.

**CAUTION: Help prevent serious personal injury. Before installing the tiller:**

- STOP tractor engine.
- ENGAGE park brake.

3. Stop tractor engine and engage park brake.

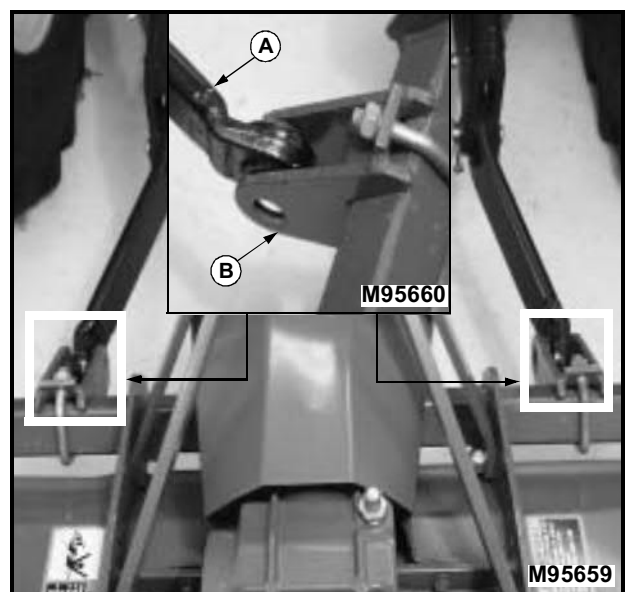

## INSTALLING

**IMPORTANT: Standard Category I pins are provided with tiller for attachment to the tractor 3-point hitch.**

4. Fasten each lower tractor draft link to tiller draft link brackets with drilled pins (C) and quick-lock pins (D).



5. Remove center link (E) from tractor 3-point hitch storage hook (F).

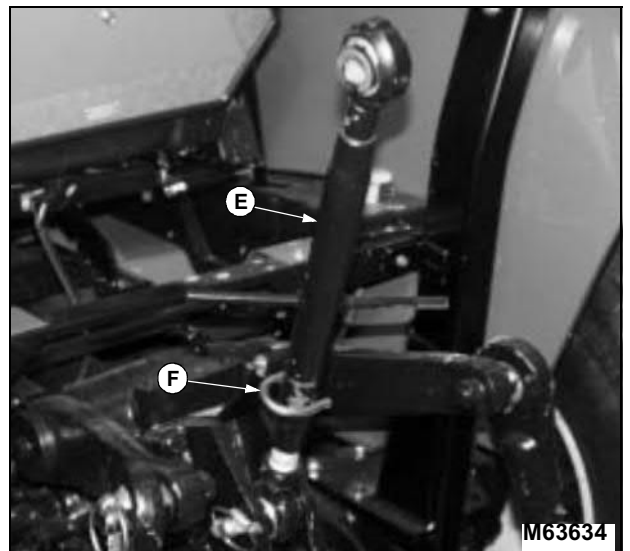

## INSTALLING

**NOTE:** It may be necessary to loosen jam nut (G) and rotate center link clockwise or counterclockwise to allow installation of drilled pin.

6. Install center link (H) onto tiller draft link bracket with drilled pin (I) and quick-lock pin (J).

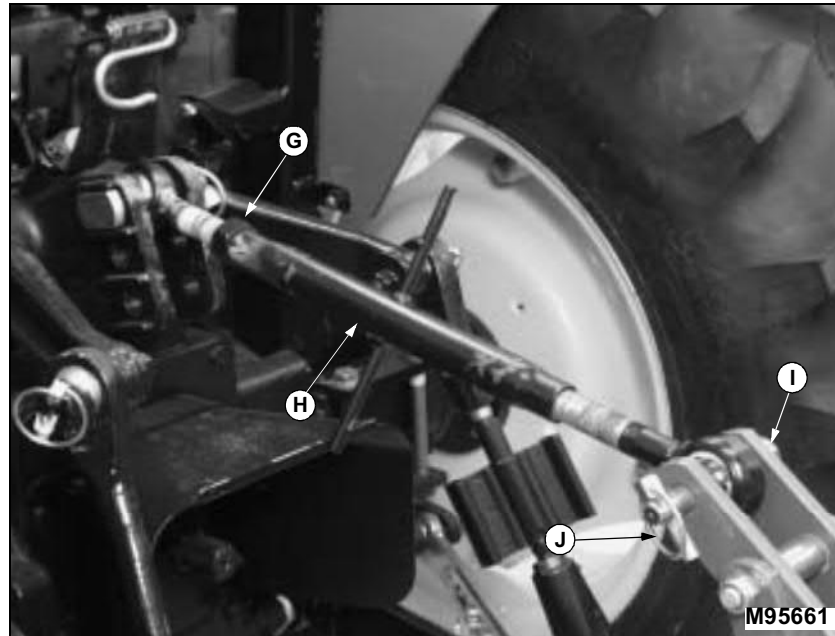

**NOTE:** Tiller must be level front to rear.

7. Install PTO driveshaft to tractor.

- Pull PTO driveshaft collar (K) rearward and install coupler onto splined tractor stub shaft.
- Push driveshaft collar completely onto the shaft until collar snaps into a locked position. Pull on shaft to make sure coupler is locked.

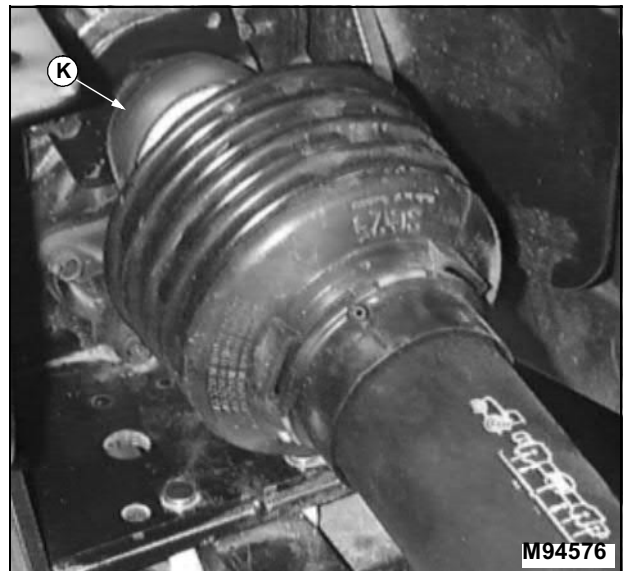

# INSTALLING

8. Start tractor engine.
9. Raise tiller approximately 25 mm (1 in.) off the ground.
10. Raise tiller park stand (L).
  - Remove spring locking pin (M) from lowered park stand.
  - Raise park stand until the bracket slot (N) and park stand hole are aligned.
  - Install spring locking pin.
11. Level tiller. (See **Leveling Tiller** in the **Operating** section.)
12. Adjust tractor 3-point hitch sway links. (See **Adjusting Sway Links** in this section)

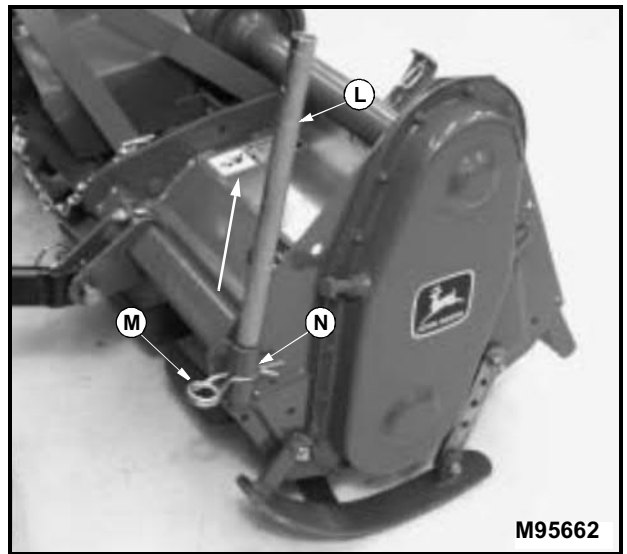

## Adjusting Sway Links

**NOTE:** Information on adjusting tractor 3-point hitch sway links can also be referred to in the tractor operator's manual.

**When sway links have been properly adjusted, side sway of tiller is minimized.**

Use 3-point hitch left and right sway links (A) to adjust tiller side-to-side sway.

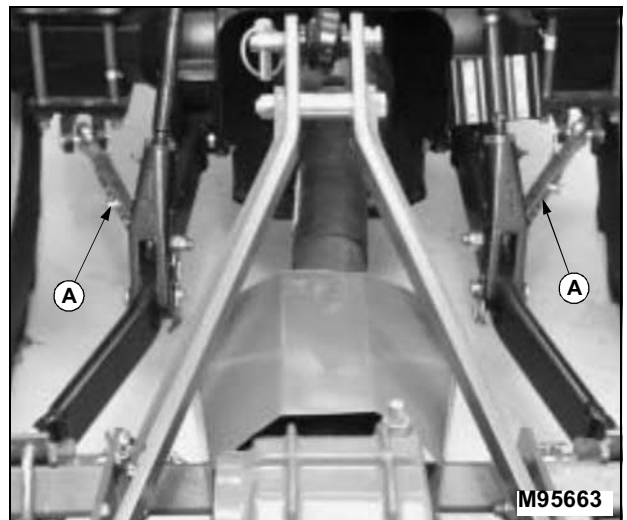

1. Remove locking ring (B).
2. Pull locking pin (C) from sway link.
3. Adjust sway links:
  - Slide links to lengthen or shorten.
  - Adjust sway links to minimize side sway to a maximum of 25 mm (1 in.) on each side.
4. Install locking pin and ring.

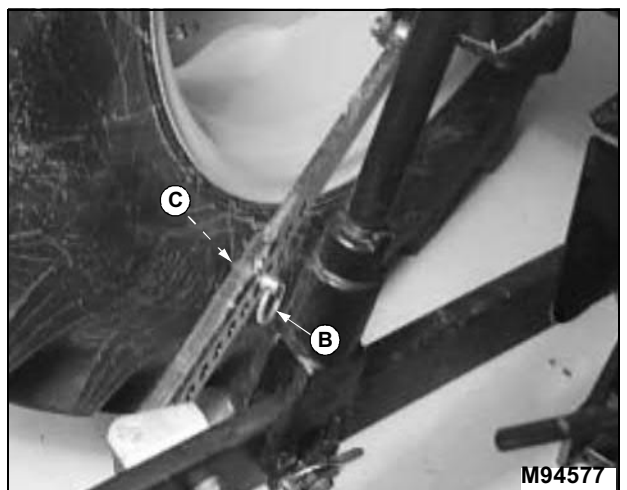

# REMOVING

## Park Vehicle Safely

- Stop vehicle on a level surface, not on a slope.
- Disengage PTO.
- Engage the park brake.
- STOP the engine.
- Remove the key.
- Before you leave the operator's seat, wait for engine and all moving parts to STOP.

## Stay Clear Of Rotating Drivelines

Entanglement in rotating driveline can cause serious injury or death:

- Wear close fitting clothing.
- STOP the engine and be sure PTO driveline is stopped before getting near it.

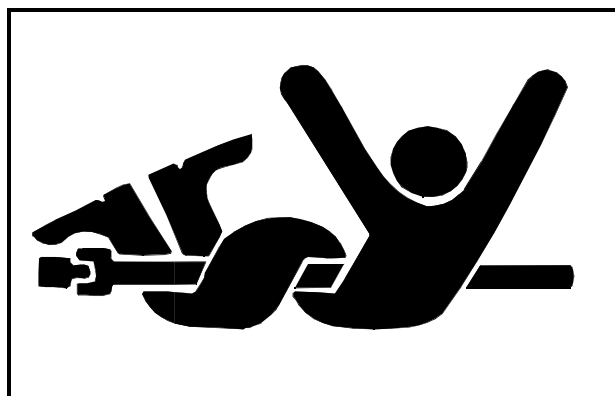

## Removing Tiller

1. Park tractor and tiller on a level surface.
2. Raise tiller.
3. Lower tiller park stand.
  - Remove spring locking pin.
  - Lower tiller park stand (A) until the bracket slot (B) and park stand hole are aligned.
  - Install spring locking pin (C).
4. Lower tiller to the ground.
5. Stop tractor engine and engage park brake.

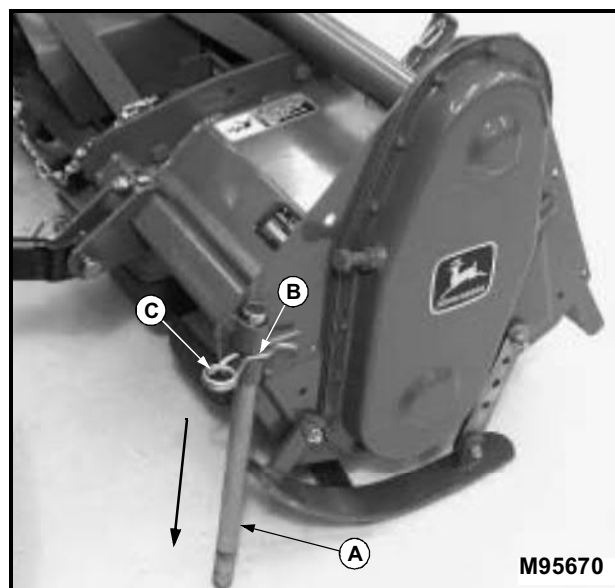

## REMOVING

6. Disconnect driveshaft (D) from tractor.

- Pull back on coupler to release driveshaft from the LOCKED position.

**NOTE:** It may be necessary to loosen jam nut (E) and rotate the 3-point hitch center link (F) clockwise or counterclockwise to allow removal of drilled pin (G).

**Install drilled pin and quick-lock pin back into tiller bracket for storage.**

7. Remove quick-lock pin (H) and drilled pin (G) from center link (F).

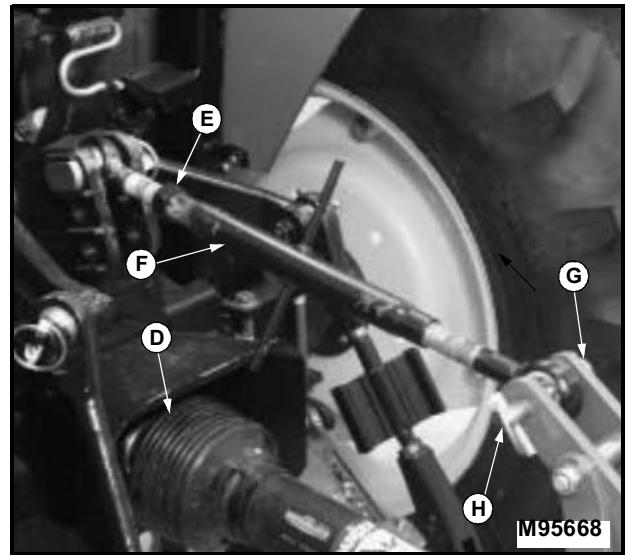

8. Install center link (F) into storage hook (I).

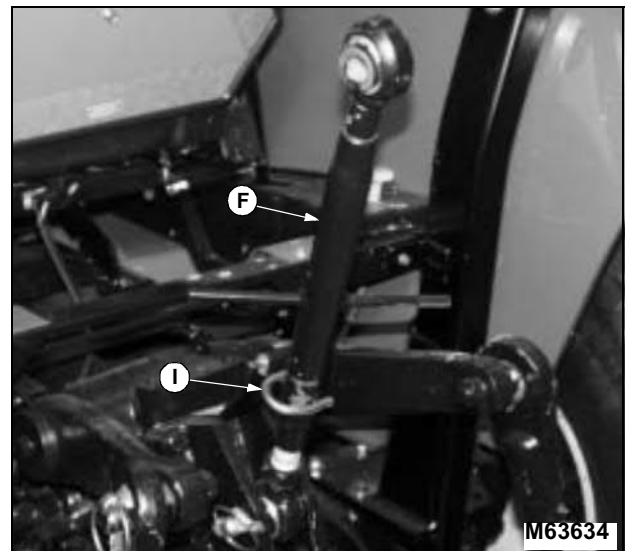

**NOTE:** Install quick-lock pins and drilled pins back into tiller draft link brackets for storage.

9. Remove tractor draft links (J) from tiller draft link brackets (K) by removing quick-lock pins (L) and drilled pins (M).

10. Drive tractor forward slowly.

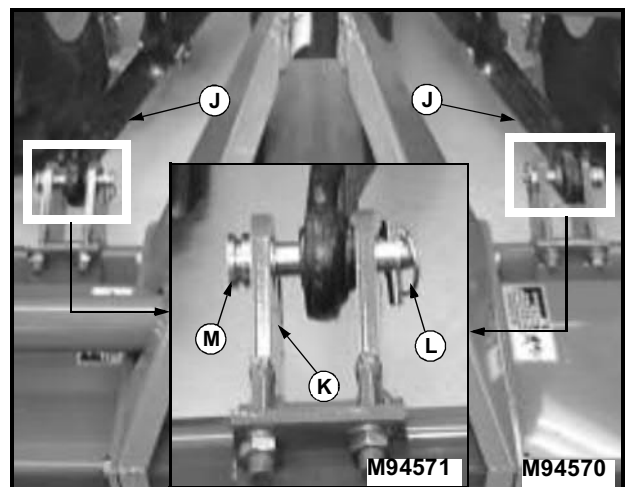

# OPERATING MACHINE

## Operate Safely

- Check vehicle brake action before you operate. Adjust or service brakes as necessary.
- Clear work area of objects that you do not want tilled into the ground or that might damage the tiller. Consider the tilling area and set up a safe tilling pattern. Do not till under conditions in which traction or stability is doubtful. Keep people and pets out of the work area. Stop machine if anyone enters the area.
- Protect your hands when you inspect or unplug the tiller. You may need gloves or tools, such as a screwdriver or scraper. Be sure hardware is tight. Repair or replace damaged, badly worn, or missing parts. Be sure guards and shields are in good condition and fastened in place. Make any necessary adjustments before you operate.
- If you hit an object, stop the machine and inspect it. Make repairs before you operate. Keep machine properly maintained and in good working order.
- DO NOT leave machine unattended when it is running.
- Only operate during daylight or with good artificial light.
- DO NOT let anyone, ESPECIALLY CHILDREN, ride on machine or vehicle. Riders are subject to injury such as being struck by foreign objects and being thrown off. Riders may also obstruct the operator's view, resulting in the machine being operated in an unsafe manner.
- DO NOT let children or an untrained person operate machine.
- Do not wear radio or music headphones while operating the machine. Safe operation requires your full attention.
- DO NOT operate the tractor and tiller when you are tired or ill.

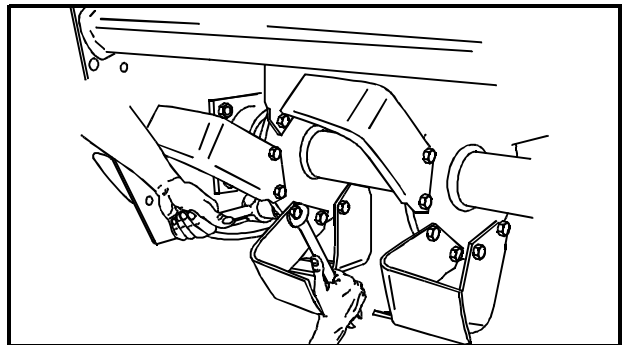
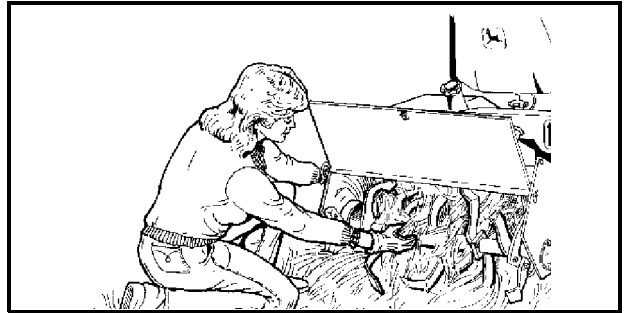
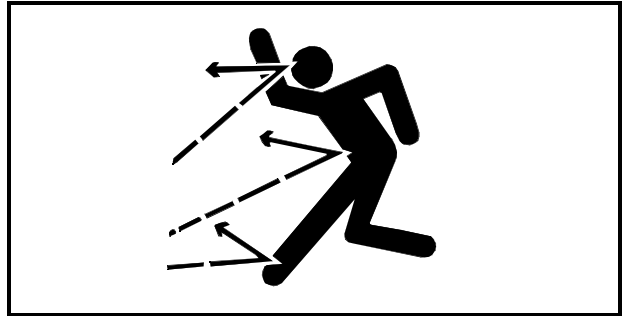

## Wear Appropriate Clothing

- Wear close fitting clothing and safety equipment appropriate for the job.
- Loud noise can cause impairment or loss of hearing, wear a suitable protective device such as earplugs.

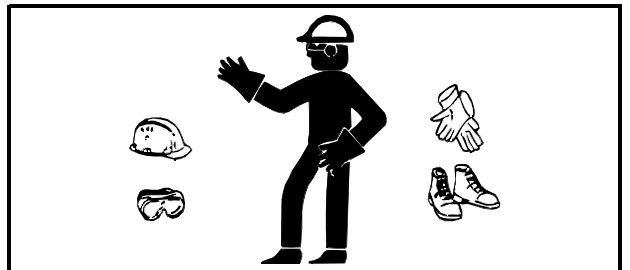

## OPERATING MACHINE

### Stay Clear Of Rotating Drivelines

Entanglement in rotating driveline can cause serious injury or death:

- Wear close fitting clothing.
- STOP the engine and be sure PTO driveline is stopped before getting near it.



### Raising and Lowering Tiller Park Stand

#### Raising Park Stand

1. Remove spring locking pin.
2. Raise park stand (A) until the bracket slot (B) and park stand hole are aligned.
3. Install spring locking pin (C).

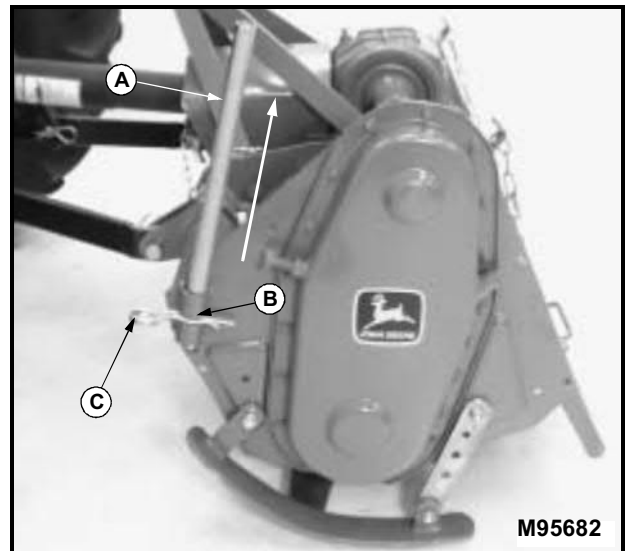

#### Lowering Park Stand

1. Remove spring locking pin.
2. Lower park stand (A) until the bracket slot (B) and park stand hole are aligned.
3. Install spring locking pin (C).

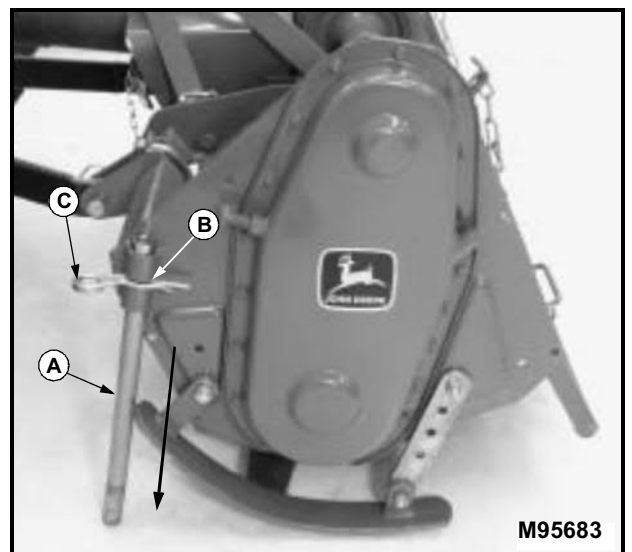

# OPERATING MACHINE

## Raising and Lowering Tiller

- CAUTION:** When tiller is raised out of the ground or tiller is lowered into the ground, tractor may surge forward.
- Be ready to STOP PTO and tractor.
  - Tractors equipped with gear transmissions, avoid **DISENGAGING** the tractor transmission before raising the tiller out of the ground.

**IMPORTANT:** To help improve universal joint life, **DISENGAGE** the rear PTO when the tiller is **FULLY** raised.

## Tractor 3-Point Hitch Controls

- CAUTION:** Excessive rate of drop speed may cause damage to the tiller or injury to bystanders. Adjust rate of drop slow enough to be safe.

**Speed of Drop/Lock Valve:** The speed of drop/lock valve (A) is used in conjunction with the rockshaft control lever. This valve will control how fast the tiller will drop when mounted on the 3-point hitch.

- **Increase Rate of Drop:** Turn valve knob (A) to the left “↺” (counterclockwise).
- **Decrease Rate of Drop:** Turn valve knob (A) to the right “↻” (clockwise).

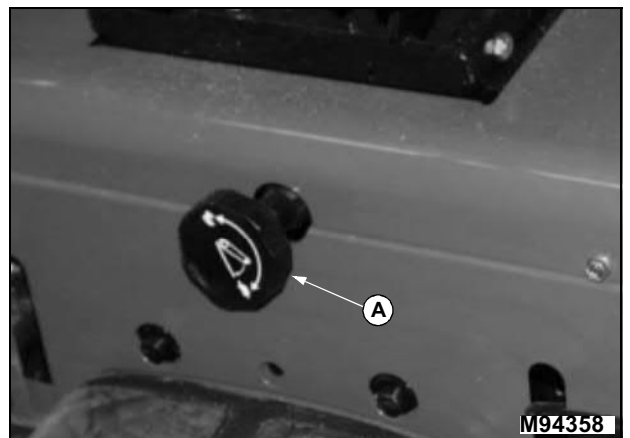

**Rockshaft Control Lever:** The rockshaft control lever (B) is used to raise and lower tiller.

**NOTE:** The rockshaft control lever has a label showing numbers 1 through 9. These numbers are for reference only. The lower the number, the closer the draft arms will be to the ground.

- **To Lower Tiller:** Push lever (B) forward.
- **To Raise Tiller:** Pull lever (B) rearward.





**Suggest:**

**If the above button click is invalid.**

**Please download this document**

**first, and then click the above link**

**to download the complete manual.**

**Thank you so much for reading**

## OPERATING MACHINE

**Depth Stop:** The adjustable depth stop knob (C) can be adjusted to maintain tiller operating depth.

- **Adjust Depth Stop:** Lower tiller to desirable operating position. Loosen depth stop knob (C) and move against rockshaft control lever (B). Tighten knob.



### Engaging and Disengaging Tiller

**CAUTION:** Help avoid serious personal injury. Clear bystanders from tilling area before engaging tiller.

**NOTE:** Run tractor engine at full throttle for best tilling results.

1. Start tractor engine.
2. Pull tractor rockshaft control lever (A) rearward to raise tiller as high as it will go.
3. Drive to tilling area and stop tractor.
4. Adjust throttle lever (B) until tractor tachometer indicator is pointing at the special marker labeled "540". Engine speed should be 2700 rpm and rear PTO speed should be 540 rpm.

**Picture Note:** Top photo shows instrument panel including throttle lever location on Model 4200–4400 series tractors.

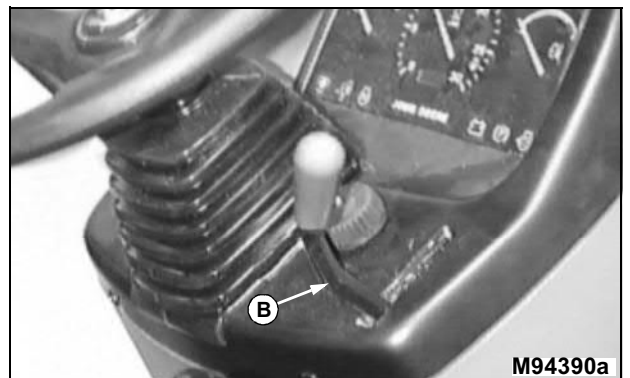

**Picture Note:** Bottom photo shows instrument panel including throttle lever location on Model 4500 series tractors.



**<https://www.ebooklibonline.com>**

Hello dear friend!

Thank you very much for reading.

Enter the link into your browser.

The full manual is available for immediate download.

**<https://www.ebooklibonline.com>**