

334, 434 and 634 Corn Attachments (Effective Serial No.334-901, 434N-462, 434W-1528 and 634N-126



JOHN DEERE

OPERATORS MANUAL

334, 434 and 634 Corn Attachments (Effective Serial No.334-901, 434N-462, 434W-1528 and 634N-126

OMN159084 A6 English

OMN159084 A6

LITHO IN U.S.A.
ENGLISH



TO THE PURCHASER

This manual contains useful information on how to operate your new John Deere Corn Attachment.

This corn attachment is built to handle a wide range of conditions with regular equipment. Field conditions vary from year to year, from day to day, and even from hour to hour. Different varieties of corn present widely different picking problems. A careful study of adjustments on your corn attachment and what they accomplish under varying conditions will allow you to reap many benefits and economies that a corn attachment can provide.

Your new corn attachment will do quality work in direct proportion to the care you use in operating it. Operate, adjust and service the attachment according to the instructions in this manual.

If you need information not covered in this manual, see your John Deere dealer. He has the latest information on how to get the best service from your corn attachment and can give you prompt service in the field or in his shop.

When in need of parts, go to your John Deere dealer. He carries genuine John Deere parts for your Corn Attachment. Be prepared to give him the serial number of your corn attachment and the year purchased. This information should be recorded in the space below as soon as you have received your corn attachment.

Serial Number
Date Purchased

You will find the serial number plate on the left-hand auger housing as shown.

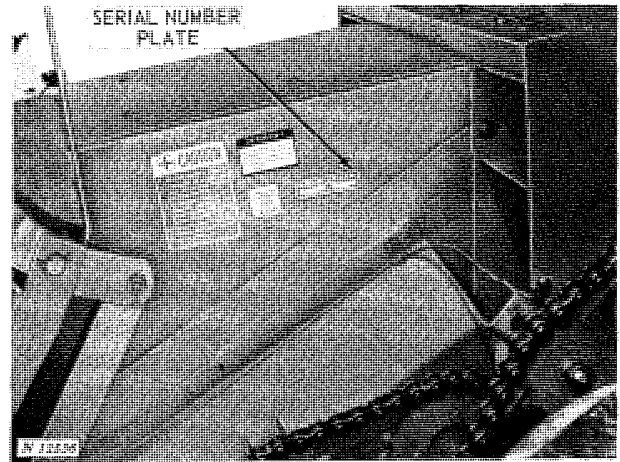

CONTENTS

	Page
Specifications	3
Operation	4-21
Attachments	22-23
Lubrication	24-26
Trouble Shooting	27-32
Service	33-37
Removing Corn Attachment	38-40
Installing Corn Attachment	41-48
Assembly	49-54
Index	55-56

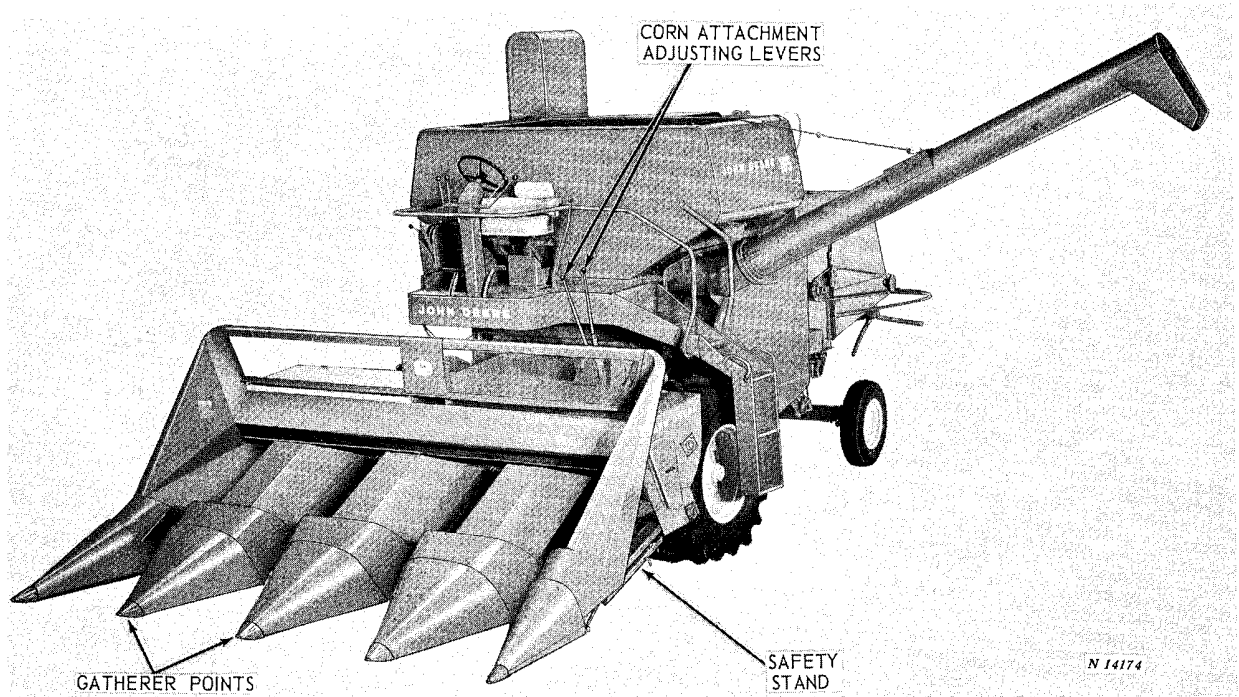

John Deere 434W Corn Attachment on 105 Combine

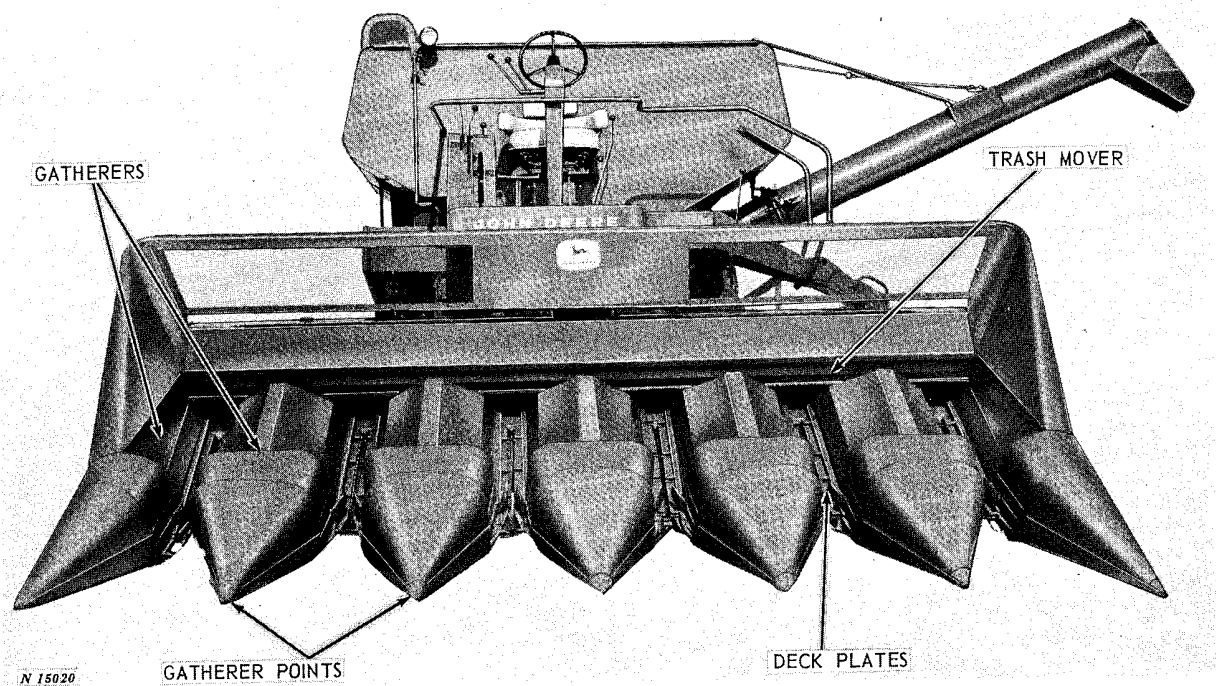

John Deere 634N Corn Attachment on 105 Combine

<https://www.ebooklibonline.com>

Hello dear friend!

Thank you very much for reading.

Enter the link into your browser.

The full manual is available for immediate download.

<https://www.ebooklibonline.com>

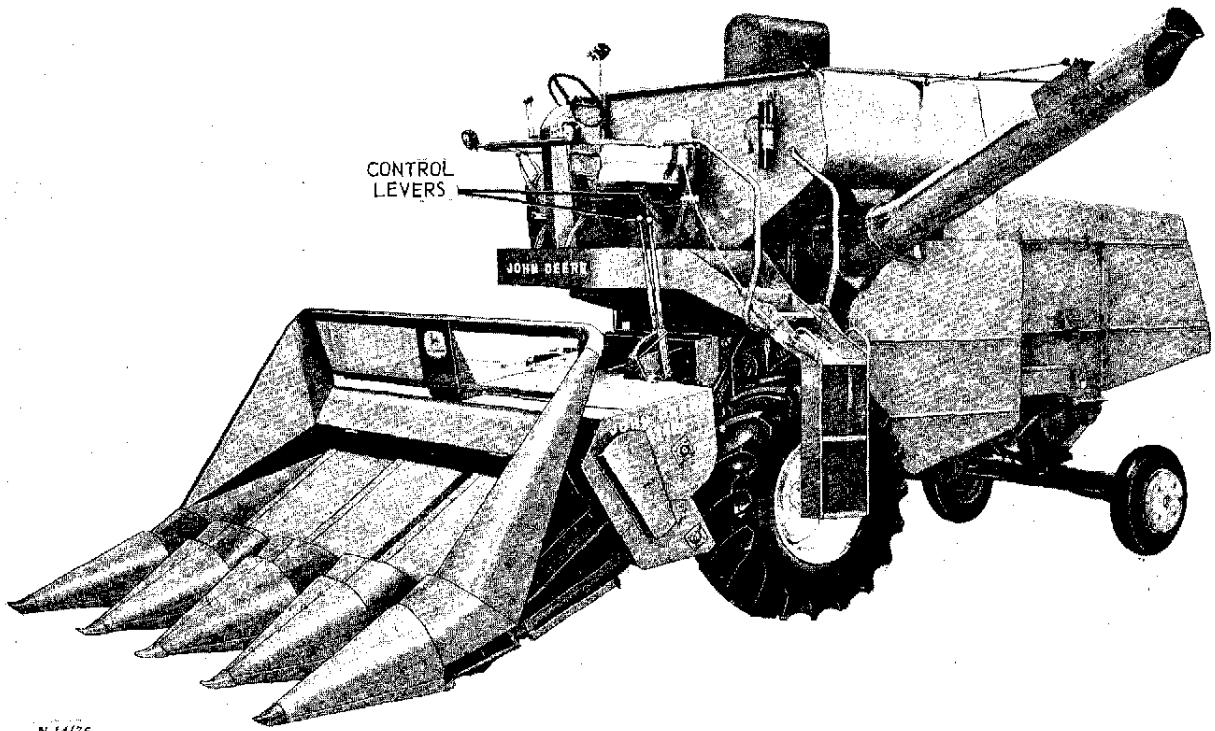

John Deere 434N Corn Attachment on 95 Combine

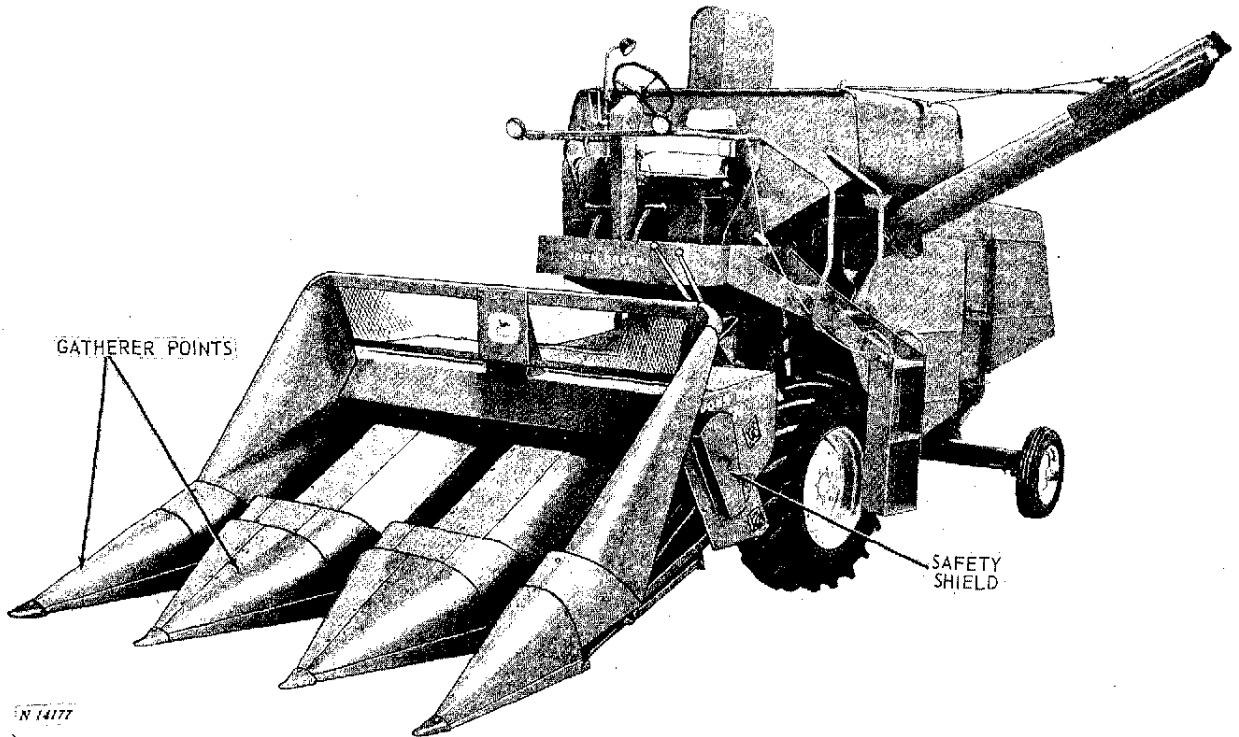

John Deere 334 Corn Attachment on 55 Combine

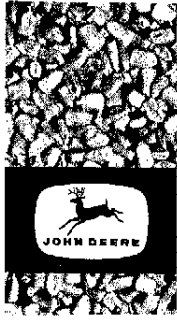

SPECIFICATIONS

John Deere Combine required-

334	55, 95, or 105*
434W and 434N	95 or 105
634N	105**

Number of Rows-

334	3
434W and 434N	4
634N	6

Row Widths Handled-

334	30, 36, 38, and 40 inches
434N	28 and 30 inches
434W	36, 38, 39, and 40 inches
634N	28 and 30 inches

Gatherer points. Hinged above gatherer chains

Number of gatherer chains per snapping unit 2

Type of gatherer chains . Endless steel roller chain (no master connecting link)

Speed of gatherer chains — 326 fpm (regular) (feet per minute) 279 fpm and 373 fpm (special).

Minimum clearance between gatherer chains and ground 0 inches and up

Distance gatherer chains ahead or fluted stalk roll points 10 inches

Length of fluted stalk rolls less points 30 inches

**The 334 Corn Attachment should not be mounted on the 105 Combine when the 334 is set for 30-inch rows, because the drive wheel will run over unpicked corn.*

***The 105 Combine must be equipped with 23.1 x 26 front tires.*

Length of fluted stalk rolls including points 38-1/2 inches

Fluted stalk roll adjustment . . . By operator from combine platform on 334 and 434 only

Deck plate adjustment By operator from combine platform

Conveyor from gatherers to combine Augers

Approximate over-all width for storage-

334	9 feet 8 inches
434N	11 feet 5 inches
434W	13 feet
634N	15 feet 10 inches

Approximate over-all length for storage 12 feet

Weight of corn attachments only-

334 for 55 Combine	3150 pounds
334 for 95 Combine	3208 pounds
334 for 105 Combine	3251 pounds
434N for 95 Combine	3861 pounds
434N for 105 Combine	3904 pounds
434W for 95 Combine	3946 pounds
434W for 105 Combine	3989 pounds
634N for 105 Combine	5010 pounds

ATTACHMENTS

Row Spacing Parts (see page 21).

- Down Corn (see page 23).
- Trash Mover (see page 23).
- Corn-Cob Mix (see page 22).

For other attachments available for the Combine, see your John Deere dealer.

(Specifications and design subject to change without notice.)

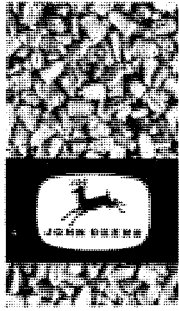

OPERATION

PROPER INSTALLATION

Be sure the corn attachment is properly installed on the combine. Improper installation can cause inferior work and damage to the corn attachment and combine. After corn attachment is completely installed, check over the entire machine, being sure shields, sprockets, chains, and all other parts are properly attached, and adjustments made as illustrated. Be sure all nuts, pins, and keys are tight and cotter pins are spread.

BEFORE OPERATION

Before putting the corn attachment in the field for the first time, lubricate it thoroughly and operate at slow speed for ten minutes, making sure that all parts are working freely. If there is no binding or heating, run at fast idle speed for approximately five minutes, if this has not already been done by the dealer. Next, go over the entire machine to be sure that all bolts are tight, and that lubricant is reaching all bearings. Be sure to check the tension of all chains.

IN THE FIELD

Take pride in doing the best work possible under all conditions. Follow the rows carefully; set gatherer points and tilt machine to pick up the down and leaning stalks; set stalk rolls so corn is not mutilated; and adjust for damp or dry corn. Adjustments are provided on the machine to meet these conditions.

ADJUST MACHINE PROPERLY

Successful operation, quality of work, and length of life of the corn attachment depend greatly upon adjusting the corn attachment and combine to meet your specific field conditions, and on proper lubrication.

After several rounds, check the adjustments to be sure you are getting the best possible sample of corn in the grain tank.

HARVEST EARLY

Early harvesting, before corn gets too dry, is one way to keep field losses low. Agricultural engineers suggest that when early maturing corn reaches 26 to 27 percent moisture, farmers with dryers can start harvesting. If you're set up to store high moisture corn, harvesting can start when corn is at 30 percent moisture.

If corn is to be sold without drying, wait until the moisture content is slightly below 20 percent. For safe storage in anything but an airtight silo, moisture should not exceed 12-1/2 percent.

Early harvesting will also eliminate the troubles and disagreeable features that accompany frozen ground, extremely cold weather, and dried out, frozen, and rotten cornstalks.

DRIVE CAREFULLY

The combine should travel in the same direction that the field was last cultivated.

Listen for slipping clutches and watch for deep furrows, rocks, or other obstructions which the gatherer points may strike.

Drive the combine carefully so the corn attachment will stay on the rows. Raise the corn attachment when crossing the end of the field.

If the unit begins to plug, do not slow down the combine engine. Keep the engine at operating speed and decrease the ground speed with the variable speed control or by disengaging the foot clutch until the unit has cleared itself.

Do not use a corn stalk or stick to clean stalk rolls of an ear or trash while corn attachment is operating. If for any reason the corn attachment should become clogged, stop the combine engine and then remove obstacle. Keep hands completely away from stalk rolls while machine is in motion.

Never clean, lubricate, or adjust corn attachment or combine while either is in motion. Be sure to stop the combine engine. Keep hands and clothing away from moving parts!

CHECK GROUND SPEED

In average conditions, the corn attachment will do best work when traveling at a moderate rate of speed.

In well standing corn, the forward movement of the machine should be approximately the same as the rearward movement of the gatherer chain flights, so the flights can help guide the stalks into the stalk rolls.

If the ground speed is too fast, the chains push stalks forward and knock off the ears. If the ground speed is too slow, the chains jerk the stalks back into the unit, possibly breaking the stalks or knocking off the ears.

FIELD LOSSES

As the season progresses, field losses will increase. The corn dries out causing more shelling, and stalks become brittle causing more ear drop.

However, these losses can be reduced to a minimum by keeping your machine in proper adjustment, following the rows carefully, and picking at the proper speed according to yield and field conditions.

ESTIMATING SHELLED CORN LOSS

Count the number of kernels around a hill in a square 40 by 40 inches. Make a count several places in the field and average the count.

To get an accurate count and to determine where loss is occurring, first take a count from each row behind the corn attachment and then from behind the combine to determine the total loss. If the combine is equipped with the three-row corn attachment, take one sample from each of the three rows and divide by three to determine the average number of kernels lost. If the combine is equipped with the four-row machine, take one sample from each of the four rows and average the count.

If you find an average of 20 kernels per square, you are losing one bushel per acre; 80

kernels per square would mean a loss of four bushels per acre.

Be sure to clear away all husks and leaves and shake any remaining kernels from husks.

ESTIMATING EAR CORN LOSS

Mark off 133 feet (about 43 normal walking steps for an adult man) along one row. Each good sized ear (about 3/4 pound) represents one bushel of ear corn lost per acre.

Make the test several places throughout the field for a more accurate check. Be sure to kick the husks and stalks to find ears that are hidden.

To get the most accurate check on the efficiency of your corn attachment, estimate the ear corn loss before as well as during and after the field is picked, because some ears drop off the stalks before harvest.

GATHERERS

EAR SAVERS

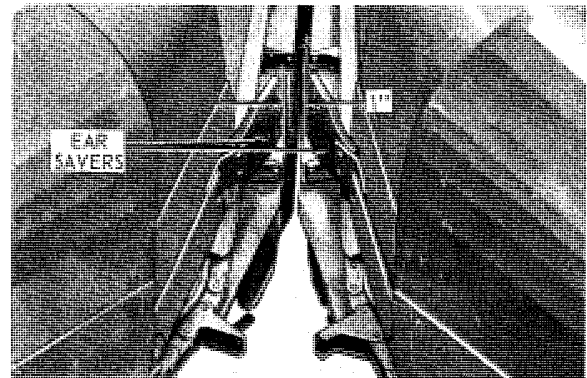

Ear savers are located above the gatherer chains. Ear savers prevent the loose ears from sliding over the gatherer chains to the ground at the end of the rows and other times when stalks are not being fed through the corn attachment.

The ear savers should always be spaced so the rear ends are at least one inch apart.

In down corn and if the stalks tend to plug up at the gatherer throat opening, remove the ear savers from the corn attachment.

The left- and right-hand ear savers are identical. See page 57 for installation instructions.

6 Operation

GATHERER POINTS

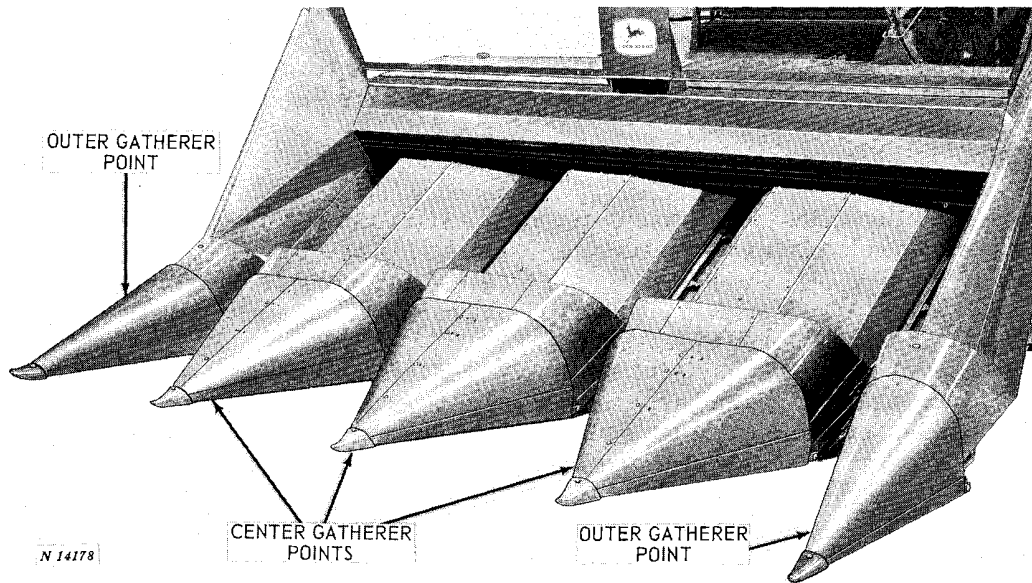

GATHERER CHAINS

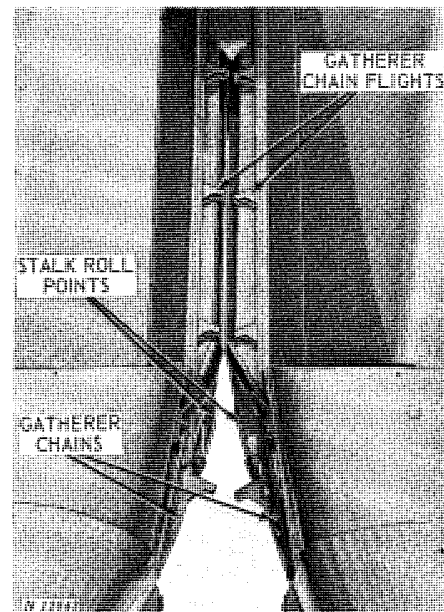
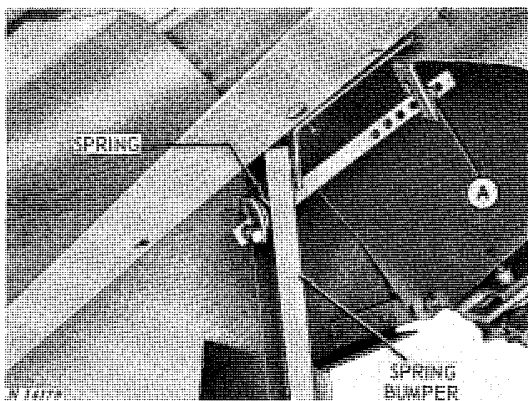

The gatherer points are hinged to follow the contour of the ground. They can also be raised and locked in any one of a number of positions by repositioning bolt "A."

When operating, have the gatherer points just touching the ground.

In muddy conditions or in snow, raise and lock gatherer points high enough to prevent the points from scooping material into the throat opening, thereby clogging the opening.

Make sure the spring is located on the adjusting straps just below the spring bumper. The spring helps absorb shock loads.

The gatherer chains run well beyond the points of the fluted stalk rolls. The chains can be run touching the ground if necessary to bring low hanging ears and down stalks into the stalk rolls.

CAUTION: Be careful to avoid rocks and other obstructions in the row when running gatherers close to the ground.

The gatherer chains should be oiled daily. See page 25.

The gatherer chains are designed to run in the same plane. Also, the chain flights are positioned so they are approximately opposite one another.

Gatherer Chain Spacing

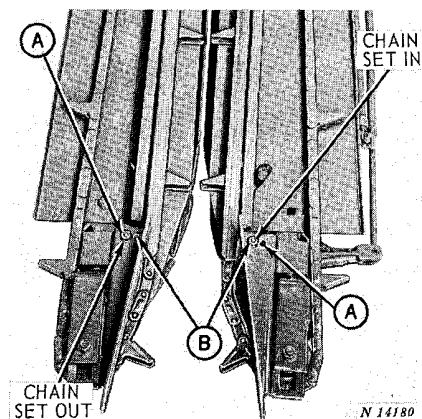

Illustrated with Gatherer Shields Removed

Under certain conditions, it may be desirable to have the gatherer chains more aggressive. This is done by moving the chains closer together at the front of the machine. This should be done in fields where the yield is light, cornstalks are smaller than usual, the corn is down or material hesitates in the throat area. Gatherer chain speed should be reduced in down corn. See page 8 for reducing gatherer chain speed.

To move the chains closer, remove the bolt at "A." Move the gatherer chain and guide closer to the opposite chain until the other holes in the guide bracket at "B" line up with the guide. Set all gatherer chains the same.

The gatherer chains are factory assembled with one chain in and the other chain out as shown above.

Adjusting Gatherer Chains

The gatherer chain is properly adjusted when the idler sprocket moves rearward approximately 1/4 to 3/8 inch (before it becomes solid) when the gatherer chain is pulled outward. Make sure the sliding mechanism is free from dirt and foreign material which would restrict the idler sprocket movement.

Do not allow gatherer chains to become too loose. If chains become too loose, excessive wear of deck plates and chains will result. Loose gatherer chains will also get out of time and cause plugging.

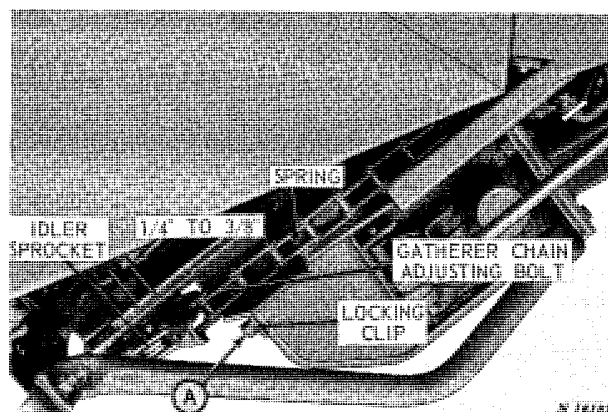

To adjust the gatherer chain tension, raise the corn attachment. Lower the safety stands as shown on page 21. Loosen the bolt at "A" which holds the locking clip in place. Slide the clip down so it is free of the gatherer chain adjusting bolt. Adjust the gatherer chain adjusting bolt until the desired chain tension is obtained. Secure the adjustment by reinstalling the locking clip over the bolt.

Gatherer Drive Chain

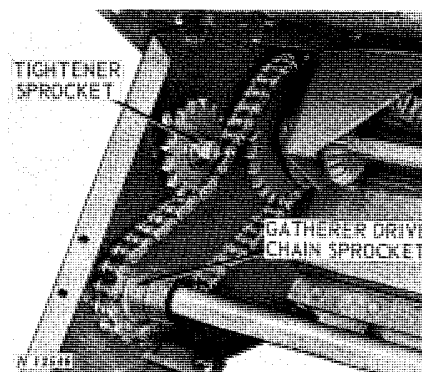

Adjust the gatherer drive chain tightener sprocket until the desired chain tension is obtained. See page 15. The shield does not have to be removed.

The gatherer chain speed should closely approximate the ground travel speed of the combine.

The corn attachment is regularly equipped with a 14-tooth gatherer chain drive sprocket, which is recommended for use when traveling at approximately 3 miles per hour.

A 12-tooth sprocket and a 16-tooth sprocket are available as special equipment.

8 Operation

If a slower combine speed is desired, decrease the gatherer chain speed by installing the 12-tooth drive sprocket (N14273N). In down corn conditions it is recommended that the 12-tooth drive sprocket be installed and combine speed be reduced.

If a faster combine speed is desired, increase the gatherer chain speed by installing the 16-tooth drive sprocket (AN12709N).

To change the drive sprocket, see page 36.

ADJUSTING STALK ROLLS ON 334 AND 434 CORN ATTACHMENTS

The stalk rolls pull the cornstalks down so the ears will be snapped on the deck plates.

IMPORTANT: Proper adjustment of the stalk rolls and deck plates is necessary to obtain maximum performance from the corn attachment and to hold field losses to a minimum. Deck plate adjustment is explained on pages 11 to 14.

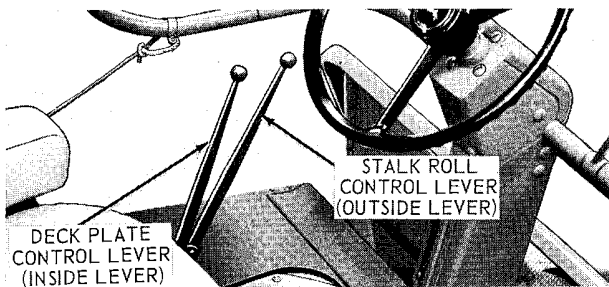

The operator can change the roll spacing from the combine operator's platform with the stalk roll adjusting lever. The outside lever controls and operates all the adjustable rolls simultaneously.

Push the lever forward to open the rolls; pull it rearward to close the rolls.

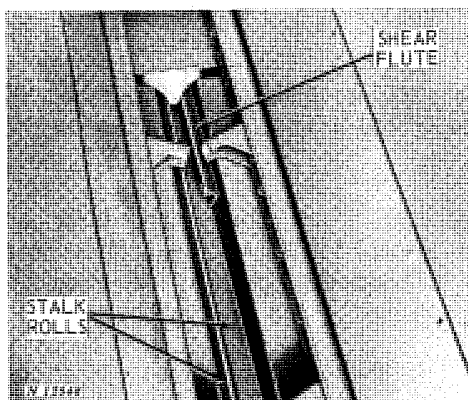

The stalk roll spacing can be changed while the machine is in operation. The stalk rolls should be open far enough so the ears are normally snapped off approximately one-half way or farther up the deck plates.

STALK ROLL SPACING

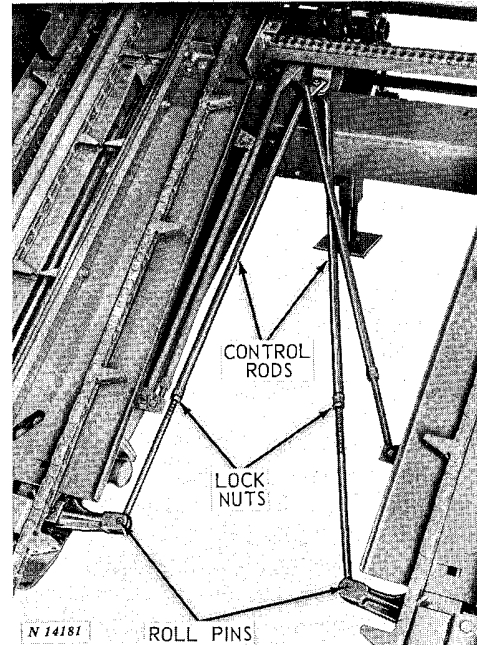

Illustrated with Shields Removed

It is very important that the spacing of all stalk rolls is the same. To check spacing, pull the lever rearward as far as it will go. All the rolls should have the same space between the bearing box flanges (see illustration on page 9). If one or more of the rolls are not the same as the others, adjustments are provided so all the rolls can be set the same.

Raise the corn attachment and lower the safety stands.

From under the corn attachment, loosen the lock nut on the stalk roll adjusting rod that needs adjusting. Remove the roll pin, holding the control rod to the stalk roll control linkage. Turn the control rod until the distance between the stalk roll bearing box flanges is the same as the others.

Replace the roll pin. Secure the new stalk roll setting by tightening the lock nut.

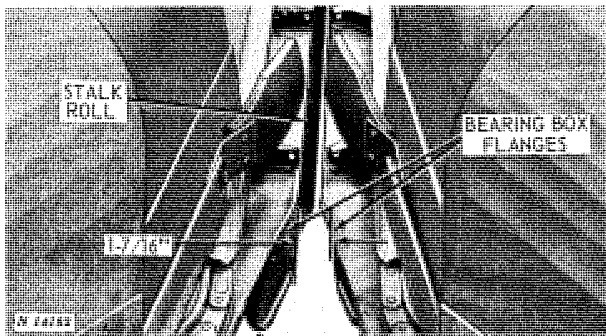

With the adjusting lever at the rear of the quadrant, all the rolls should have a spacing of 1-7/16 inches (plus or minus 1/16 inch) between the bearing box flanges at the front of the stalk rolls.

If this distance is more or less than the 1-7/16 inches required, adjust the stalk roll linkage.

STALK ROLL ADJUSTING LEVER

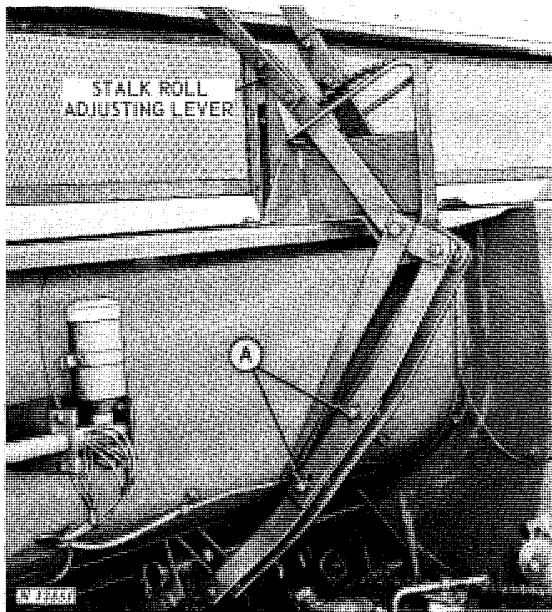

The stalk roll linkage is located right below the lever.

If the distance is more than 1-7/16 inches with lever at the rear of the quadrant, loosen the bolts at "A." Move the lever forward three or four notches. Tighten the bolts at "A." Pull the lever back to the rear of the quadrant. Use this method until all the bearing box flanges are 1-7/16 inches apart.

If the distance is less than 1-7/16 inches, push the lever forward until the recommended distance between the bearing flanges is obtained. Then loosen the bolts at "A." Pull the lever rearward. Make sure the bolts at "A" are loose enough so the bearing spacing is not changed. After the lever is pulled all the way back, check the bearing spacing. If it is still within the recommended distance, tighten the linkage bolts.

ADJUSTING STALK ROLLS ON 634N CORN ATTACHMENT

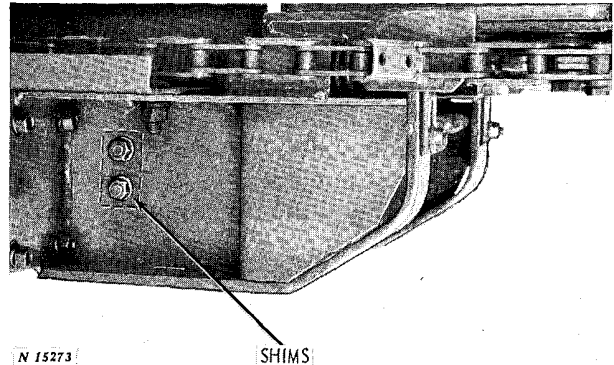

The stalk roll openings can be increased or decreased by adding or removing shims.

The shims are located between the outer gatherer support and stalk roll bearing support.

When adding or removing shims, the trash knives also have to be adjusted. See page 14 to adjust trash knives.

STALK ROLLS

TIMING STALK ROLLS

If the stalk rolls are not in time, the flutes may break off the stalks. When timed properly, the flutes on the rolls will alternate smoothly and there will be no clashing when the rolls are turned.

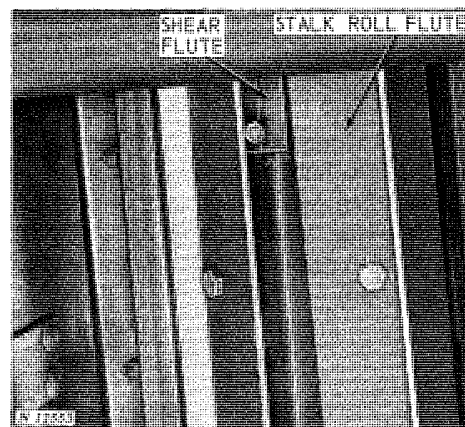

10 Operation

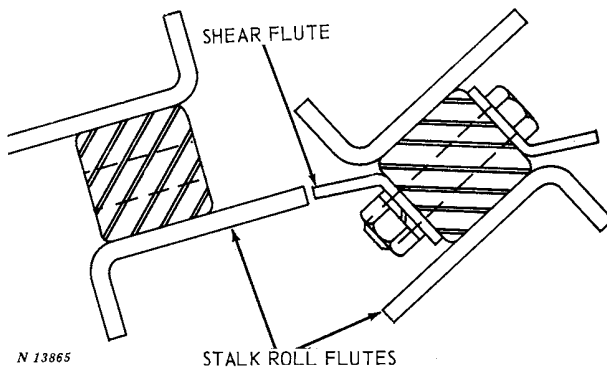

The shear flutes on the stalk rolls are designed to cut off any stalks that may have reached the end of the stalk rolls. The shear flute must be positioned so it is opposite a stalk roll flute as shown above. If not, the flutes must be timed.

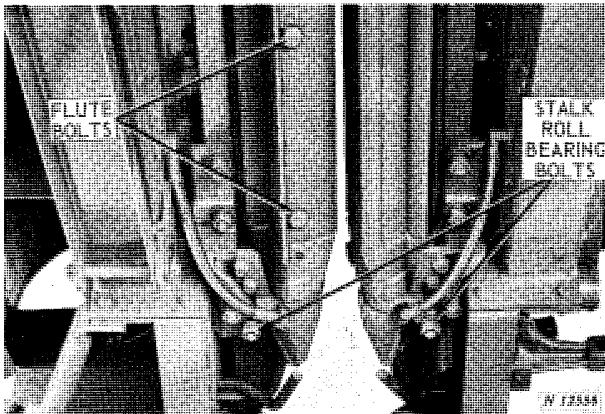
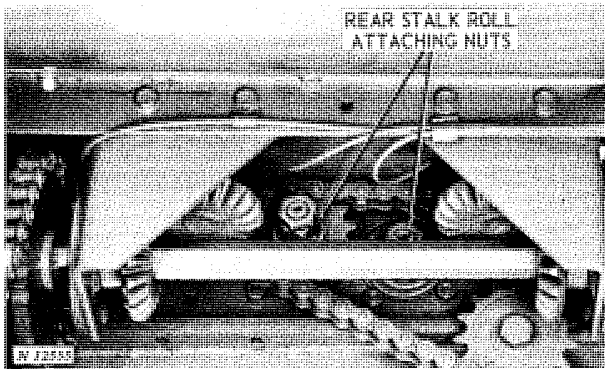

To time the shear flutes on the stalk rolls, remove the two nuts from the rear end of either roll (preferably the roll without the drive sprocket). Remove the bearing bolt at the front of the same roll. Pull the free roll down until the gears are out of mesh.

When the rolls are positioned properly as described earlier, slide the roll back into place. Replace the lower stalk roll bearing bolt and nut and the two nuts on the upper end of the stalk rolls. Tighten all nuts and bolts.

STALK ROLL BOLTS

Periodically check the nuts on the bolts through the stalk roll bearing assembly. These nuts should be tight at all times. If the bolt is not tight, tighten to a minimum of 85 ft-lbs torque.

At the same time, check the nuts holding the stalk roll flutes in place. They must be tight at all times. Tighten these bolts to 85 ft-lbs torque.

IMPORTANT: Use only 1/2 to 2-1/4-inch high-strength bolts to hold the flutes to the rolls.

STALK ROLL DRIVE CHAIN

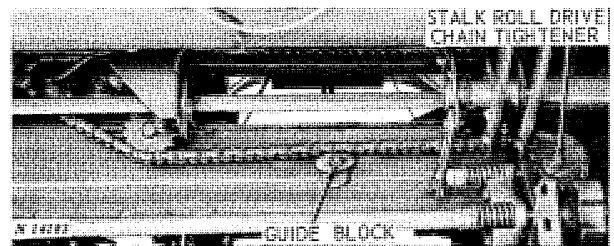

334 and 434 Corn Attachments

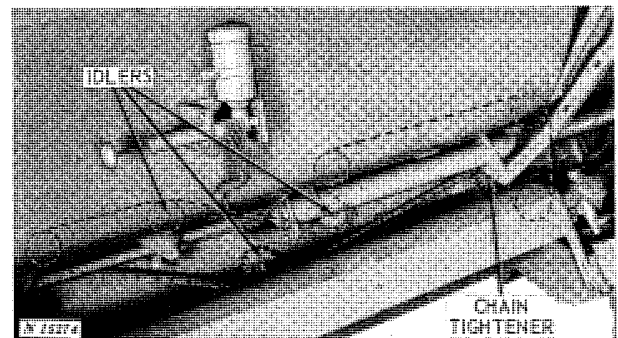

634N Corn Attachment

Adjust the stalk roll drive chain with the tightener sprocket in front of the main gear case. See page 15 for the correct chain tension.

Adjust the guide block so it just carries the chain and prevents it from slapping.

DECK PLATES

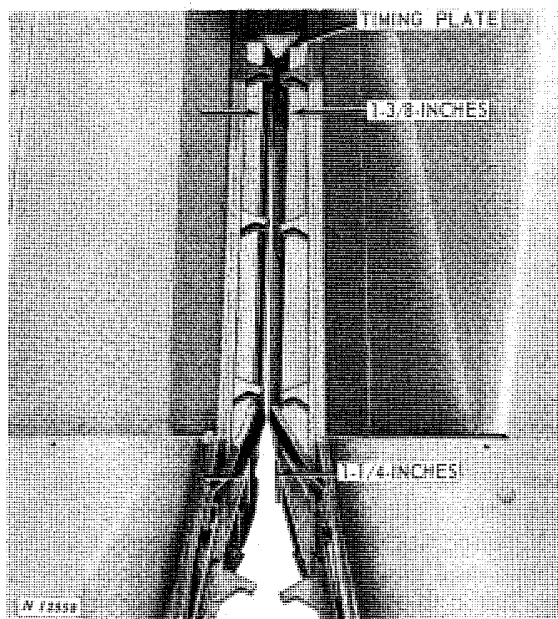

The deck plates snap ears from the stalks as the stalks are pulled down by the stalk rolls. The deck plate spacing can be adjusted, to meet varying crop conditions, by moving the inside lever from the combine operator's platform.

The deck plate lever controls and operates simultaneously one deck plate per row. Move the adjusting lever forward to open the deck plates and rearward to close the plates.

NOTE: The center of the space between deck plates should be located over the center of space between stalk rolls.

For most conditions, adjust the deck plate lever so the spacing between the deck plates is 1-3/8 inches at the rear, and 1-1/4 inches at the front, with lever in middle of quadrant.

Increase the deck plate spacing if the stalks and ears are larger than average. Decrease the spacing if the stalks and ears are smaller than average. If spacing is too wide for a given condition, ears will contact the stalk rolls causing ear butt and tip shelling.

A good method of checking to see if the plates are set too far apart is to take the tip of an average size ear of corn and see if it will fit far

enough between the deck plates to come in contact with the stalk rolls. If it does, decrease the deck plate opening.

CAUTION: Shut off combine engine before placing hands near stalk rolls.

If spacing is too narrow, stalks may tend to break off and plug the gatherer throat opening, overloading the combine.

IMPORTANT: The deck plates should be set so each deck plate is the same distance from the center of the timing plate when the control lever is in the center of the quadrant. Spacing between all the deck plates for all the rows must be set the same.

The space between deck plates should normally be 1/8-inch wider at the rear than at the front. However, in extreme down corn conditions, set the front of the deck plates so they have the same space openings as at the rear of the deck plates.

DECK PLATE ADJUSTING LEVER

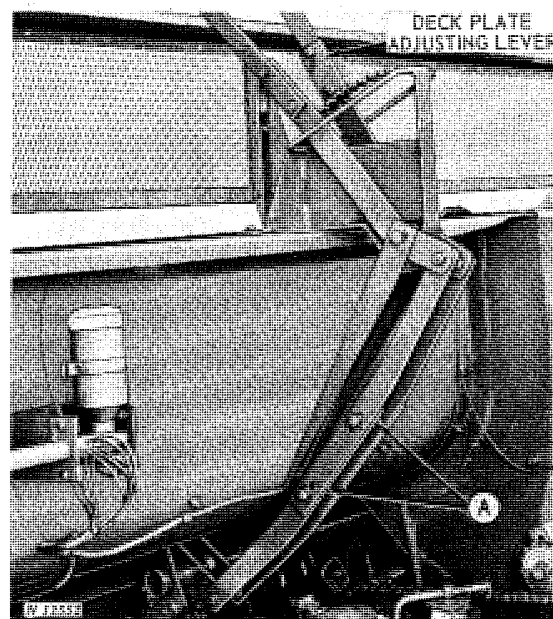

434W Corn Attachment

For normal adjustment, lever should be in middle of quadrant when deck plates are spaced 1-3/8 inches at rear and 1-1/4 inches at the front.



Suggest:

If the above button click is invalid.

Please download this document

first, and then click the above link

to download the complete manual.

Thank you so much for reading

12 Operation

To adjust the lever so it will be in middle of the quadrant when the deck plates are properly spaced, move the lever until the plates are at the 1-3/8 and 1-1/4-inch spacing. Loosen the bolts at "A." Move the lever to the middle of the quadrant without disturbing the 1-3/8 and 1-1/4-inch spacing of the plates. Tighten the linkage bolts.

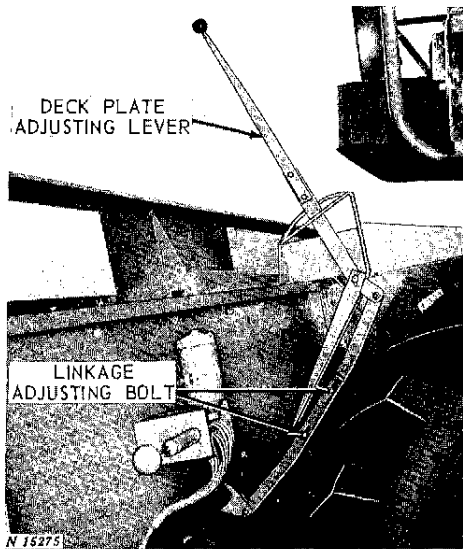

634N Corn Attachment

ADJUSTING DECK PLATES

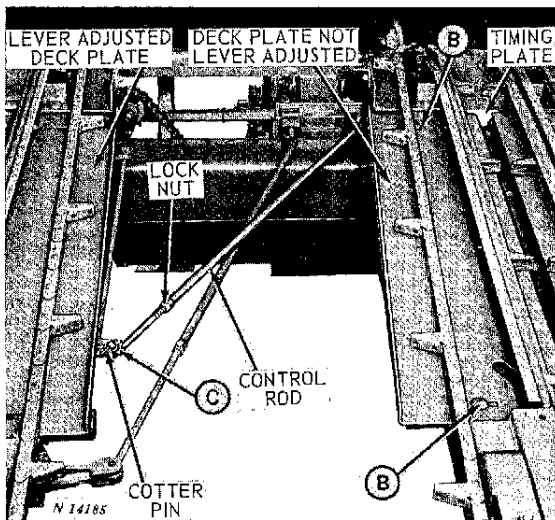

334 Corn Attachment

Deck Plates Not Lever Adjusted

The deck plates that are not adjusted by the deck plate adjusting lever are adjusted by loosening the bolts at "B" and moving the deck plates the necessary amount.

Set the rear of the deck plates so they are approximately 11/16 inch from the center of the timing plate. Adjust the front of the plate so it is parallel with the stalk roll. Tighten the bolts to a minimum of 85 ft-lbs torque.

Lever Adjusted Deck Plates

The lever adjusted deck plates of each row are adjusted by a control rod which is located beside the deck plate. The rod controls the entire length of the deck plate. To decrease spacing between the individual deck plates, loosen the lock nuts and remove the cotter pin at "C." Turn the rod so it shortens the over-all length of the linkage. To increase spacing between the deck plates, adjust the rod so it increases the over-all length of the linkage.

If the space between the plates at the front of one or more of the row units is different than the others, then adjust the over-all length of the control rod until the spacing at the front of the deck plate is the same as the others. (Normally this spacing is 1-1/4 inches with the deck plate adjusting lever in the center of the quadrant.)

<https://www.ebooklibonline.com>

Hello dear friend!

Thank you very much for reading.

Enter the link into your browser.

The full manual is available for immediate download.

<https://www.ebooklibonline.com>