

**246
Rotary Broom
For 55 Series
Tractors**



**John Deere Horicon Works
OMM77682 Issue B1
(This manual replaces OM-M77682 May 88.)**

**LITHO IN U.S.A.
ENGLISH**





THANK YOU for purchasing a John Deere product.

READ THIS MANUAL carefully to learn how to operate and service your rotary broom correctly. Failure to do so could result in personal injury or equipment damage.

THIS MANUAL SHOULD BE CONSIDERED a permanent part of your rotary broom and should remain with the rotary broom when you sell it.

MEASUREMENTS in this manual are U.S. customary units and their metric equivalents.

RIGHT-HAND AND LEFT-HAND sides are determined by facing in the direction of forward travel.

WRITE IDENTIFICATION NUMBERS in the SPECIFICATIONS section. Accurately record all the numbers to help in tracing the rotary broom should it be stolen. Your dealer also needs these numbers when you order parts.



WARRANTY is provided as part of John Deere's support program for customers who operate and maintain their equipment as described in this manual. The warranty is explained on the warranty certificate which you should have received from your dealer.



This warranty provides you the assurance that John Deere will back its products where defects appear within the warranty period. In some circumstances, John Deere also provides field improvements, often without charge to the customer, even if the product is out of warranty. Should the equipment be abused, or modified to change its performance beyond the original factory specifications, the warranty will become void and field improvements may be denied.



M41788 -UN-26FEB91



Contents

	Page	Page
Safety	1	
Preparing Tractor	8	
Installing Rotary Broom	9	
Removing Rotary Broom	13	
Operating		
Raising and Lowering	16	
Angling Broom—Hydraulic Option	16	
Angling Broom—Manual Option	16	
Engaging Broom	16	
Adjusting Lift Height	17	
Operating Tips	18	
Adjusting Debris Deflector Attachment	18	
Lubrication	19	
Service		
John Deere Parts—Your Best Choice	21	
Service Interval Chart	21	
Centering Unit	21	
Checking Gearbox Oil Level	22	
Driveshaft	22	
Chain	22	
PTO Universal Joints	23	
Mounting Frame, Swing Plate, and Broom		
Pivot	23	
Adjusting Chain	23	
Trimming Bristles	24	
Replacing Brush Sections	24	
Troubleshooting	28	
Storage	29	
Assembly	30	

Specifications 40
Index

All information, illustrations and specifications in this manual are based on the latest information available at the time of publication. The right is reserved to make changes at any time without notice.

OMM77682-B1-19-21FEB91

COPYRIGHT© 1991
DEERE & COMPANY
Moline, Illinois
All rights reserved
A John Deere ILLUSTRATION™ Manual
Previous Editions
Copyright 1988 Deere & Company

<https://www.ebooklibonline.com>

Hello dear friend!

Thank you very much for reading.

Enter the link into your browser.

The full manual is available for immediate download.

<https://www.ebooklibonline.com>

Safety

RECOGNIZE SAFETY INFORMATION

This is the safety-alert symbol. When you see this symbol on your machine or in this manual, be alert to the potential for personal injury.



Follow recommended precautions and safe operating practices.



DX,ALERT -19-03MAR93

T81389 -UN-07DEC68

UNDERSTAND SIGNAL WORDS

A signal word—DANGER, WARNING, or CAUTION—is used with the safety-alert symbol. DANGER identifies the most serious hazards.



DANGER or WARNING safety signs are located near specific hazards. General precautions are listed on CAUTION safety signs. CAUTION also calls attention to safety messages in this manual.



▲ WARNING

▲ CAUTION

DX,SIGNAL -19-03MAR93

TS187 -19-30SEP88

FOLLOW SAFETY INSTRUCTIONS

Carefully read all safety messages in this manual and on your machine safety signs. Keep safety signs in good condition. Replace missing or damaged safety signs. Be sure new equipment components and repair parts include the current safety signs. Replacement safety signs are available from your John Deere dealer.



Learn how to operate the machine and how to use controls properly. Do not let anyone operate without instruction.



Keep your machine in proper working condition. Unauthorized modifications to the machine may impair the function and/or safety and affect machine life.



If you do not understand any part of this manual and need assistance, contact your John Deere dealer.

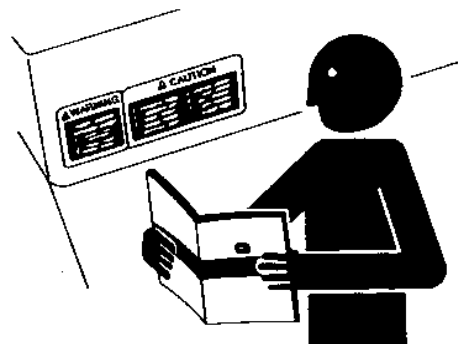

DX,READ -19-03MAR93

TS201 -UN-23AUG88



AVOID INJURY FROM THROWN OBJECTS

Clear work area of objects that may be thrown by rotary broom.

Keep bystanders out of work area.

Sweep snow, leaves or debris away from bystanders.

Protect children:

- DO NOT let children ride on tractor or broom.
- Before you back, look behind for children.
- Lower broom to ground when you are not using it.



MX,SACX,A -19-21FEB91

M41423 -UN-30AUG88

SAFETY TIPS

Allow only operator on tractor. Keep riders off.

Avoid tipping:

- DO NOT use broom near edge of ditch or bank.
- Avoid holes, rocks or roots.
- Slow down before you make turns.
- Drive up and down—not across—slopes.
- Avoid parking on slopes.
- Install correct rear weights on tractor.

3. Use broom safely:

- STOP tractor before you adjust broom.
- Lower broom to ground before you work on broom.
- DO NOT run tractor at high speed.
- Run broom only from tractor seat.
- Lower and raise broom slowly.



MX,SACX,B -19-21FEB91





WEAR PROTECTIVE CLOTHING

Wear close fitting clothing and safety equipment appropriate to the job.

Prolonged exposure to loud noise can cause impairment or loss of hearing.

Wear a suitable hearing protective device such as earmuffs or earplugs to protect against objectionable or uncomfortable loud noises.

Operating equipment safely requires the full attention of the operator. Do not wear radio or music headphones while operating machine.



DX,WEAR -19-10SEP90

-UN-23AUG68
TS206

AVOID INJURY FROM MOVING PARTS

Keep hands, feet, and clothing away from broom when brushes are turning.

STOP broom when you are not cleaning.



MX,SACX,C -19-21FEB91

-UN-29AUG88
M36022

AVOID INJURY FROM HITTING OBSTRUCTIONS

Raise broom before you drive between jobs.

Raise parking stands before you use broom.

Slow down when you cross rough ground.

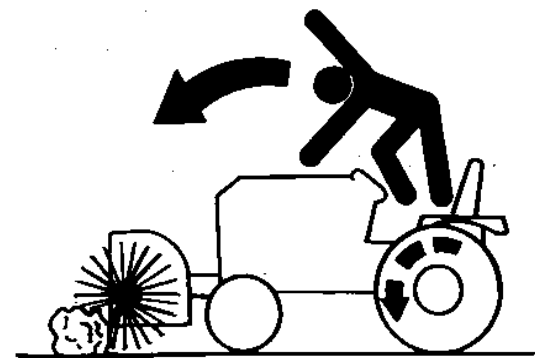

MX,SACX,D -19-21FEB91

-UN-06SEP88
M41520





STAY CLEAR OF ROTATING DRIVELINES

Entanglement in rotating driveline can cause serious injury or death.



Keep tractor master shield and driveline shields in place at all times. Make sure rotating shields turn freely.

Wear close fitting clothing. Stop the engine and be sure PTO driveline is stopped before making adjustments, connections, or cleaning out PTO driven equipment.



DX,PTO -19-12SEP95

TS1644 -UN-22AUG95

PRACTICE SAFE MAINTENANCE



Understand service procedure before doing work. Keep area clean and dry.

Never lubricate, service, or adjust machine while it is moving. Keep hands, feet, and clothing from power-driven parts. Disengage all power and operate controls to relieve pressure. Lower equipment to the ground. Stop the engine. Remove the key. Allow machine to cool.



Securely support any machine elements that must be raised for service work.

Keep all parts in good condition and properly installed. Fix damage immediately. Replace worn or broken parts. Remove any buildup of grease, oil, or debris.



Disconnect battery ground cable (-) before making adjustments on electrical systems or welding on machine.



DX,SERV -19-03MAR93

TS218 -UN-23AUG88



N CAUTION: Escaping fluid under pressure can penetrate the skin causing serious injury. Avoid the hazard by relieving pressure before disconnecting hydraulic or other lines. Tighten all connections before applying pressure. Search for leaks with a piece of cardboard. Protect hands and body from high pressure fluids.

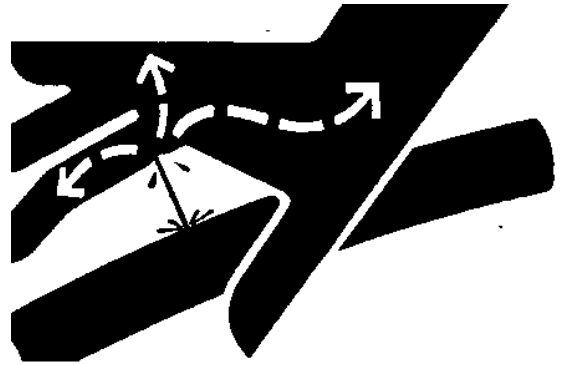

If an accident occurs, see a doctor immediately. Any fluid injected into the skin must be surgically removed within a few hours or gangrene may result. Doctors unfamiliar with this type of injury may call the Deere & Company Medical Department in Moline, Illinois, or other knowledgeable medical source.



X9811 -UN-23AUG88

DX,FLUID2,NA -19-12JUN90





READ SAFETY SIGNS

FOLLOW SAFETY INSTRUCTIONS

Carefully read all safety messages in this manual and on your machine safety signs. Follow recommended precautions and safe operating practices.

Keep safety signs in good condition. Replace missing or damaged safety signs.

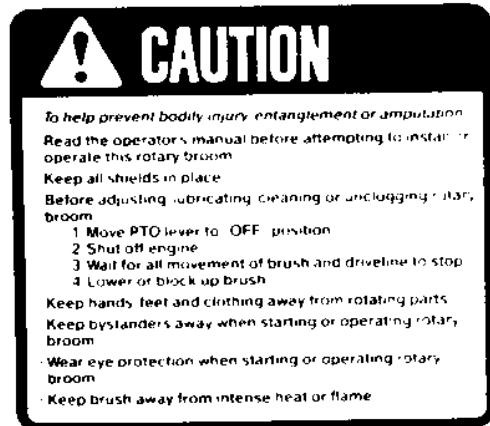

On Left Rear of Broom Housing



On Front (Both Sides) of Broom Housing

MX,SACX,E -19-21FEB91

M41521 -19-15FEB91



On Right Rear of Broom Housing



On Top of Gearbox Cover

MX,SACX,F -19-21FEB91

M41522 -19-15FEB91



P

R

O



On Right Side of Frame

MX,SACX,G -19-21FEB91

M41523 -19-14MAR69

O

F

P

R

O

O

T

Preparing Tractor

PREPARING TRACTOR

N CAUTION: To help avoid injury from tractor instability, add rear ballast to tractor.



1. Choose one of three ballast methods:

- Install maximum rear wheel weights. (Three on each wheel.)
- Fill rear tires to approximately 75% full with calcium chloride-water solution.
- Fill ballast box with sand or gravel.



NOTE: See your tractor operator's manual or your JOHN DEERE dealer for more information on rear ballast.



MX,PTCX,A -19-21FEB91

2. Inflate tires to pressure recommended in chart.

TIRE SIZE	PLY RATING	MINIMUM psi(kPa)(bar)	MAXIMUM psi(kPa)(bar)
Front			
5.00-12	4	17(120)(1.2)	40(275)(2.8)
6.00-12	4	15(100)(1.0)	28(195)(2.0)
23/8.50-12	2	12(80)(0.8)	12(80)(0.8)
6.00-14	4	15(100)(1.0)	28(195)(2.0)
25/8.50-14	4	12(80)(0.8)	22(155)(1.6)
4.00-15	4	20(135)(1.4)	46(320)(3.2)
Rear			
31/15.50-15	4	12(80)(0.8)	20(135)(1.4)
9.50-16	4	12(80)(0.8)	20(135)(1.4)
13.6-16	4	12(80)(0.8)	15(100)(1.0)
9.50-24	4	12(80)(0.8)	17(120)(1.2)



MX,PTCX,B -19-21FEB91



Installing Rotary Broom

INSTALLING BROOM

N CAUTION: To help avoid injury when you install broom:

- Install broom with two people.
- Use lifting device that safely lifts approximately 500 lb. (225 kg).

1. Remove pin (A) by removing spring locking pin and washer.

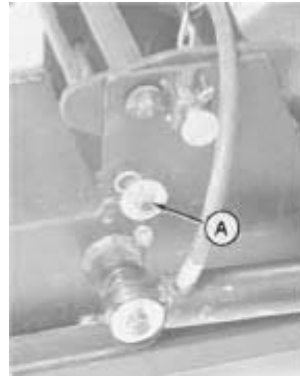

M41972
-UN-26FEB91

MX,INCX,A -19-21FEB91

2. Apply John Deere Never-Seez or equivalent to:

- Front drive shaft (A).
- PTO coupler (B).
- Pull coupler collar (C) back and forth several times.



M41973
-UN-26FEB91

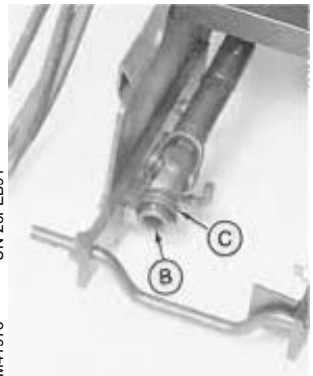

M41974
-UN-26FEB91

MX,INCX,B -19-21FEB91

3. Slowly drive tractor next to mounting frame.

4. Raise support frame onto tractor support bracket. Rod (A) MUST BE on top of hooks.



M41968
-UN-26FEB91

MX,INCX,C -19-21FEB91

5. Remove storage pin (A) from frame by removing spring locking pin.



6. Install storage pin in mast (B) and fasten with spring locking pin.



M41529
-UN-18JAN90

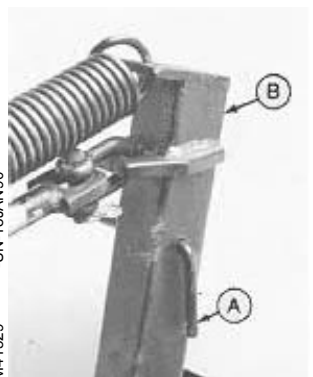

M41530
-UN-12JAN90

MX,INCX,D -19-21FEB91

Installing Rotary Broom

7. Raise stand (A) on each side of broom and fasten with pins (B).

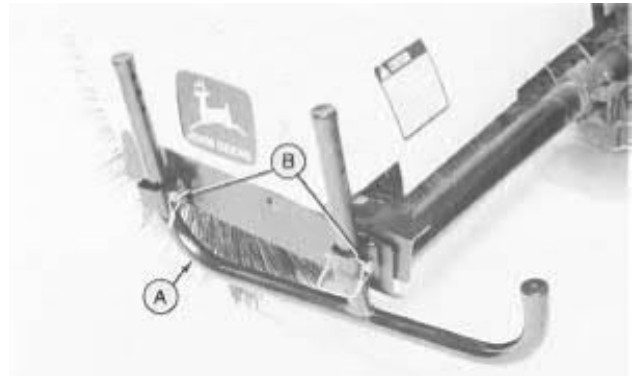

MX,INCX,E -19-21FEB91

M41531 -UN-12JAN90

8. Turn spring-loaded pin (A) to left until it is out of slot.



9. Raise lever (B) until pin goes into hole.

10. To fasten frame to front drive:

- Pull each spring-loaded pin (C) out. Turn it to right until it fits in slot.
- Raise frame until each pin (D) fits in slot on tractor front drive.
- Release spring-loaded pins. Rotate pins forward until they go into holes in front drive.

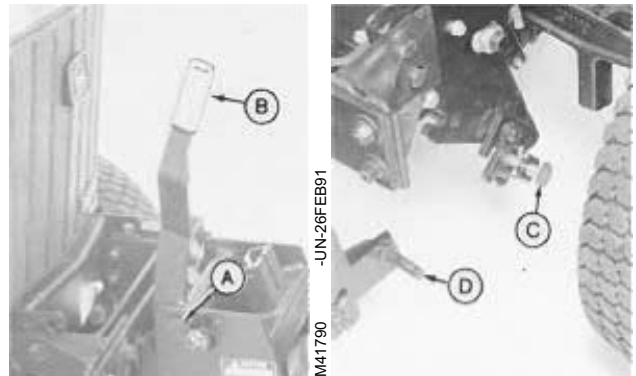

MX,INCX,F -19-21FEB91

M41789 -UN-26FEB91

11. Install pin (A) in mounting frame and fasten with spring locking pin and flat washer.



12. Loosen nut (B) on each side of frame. Put each support (C) under pin and tighten nut.

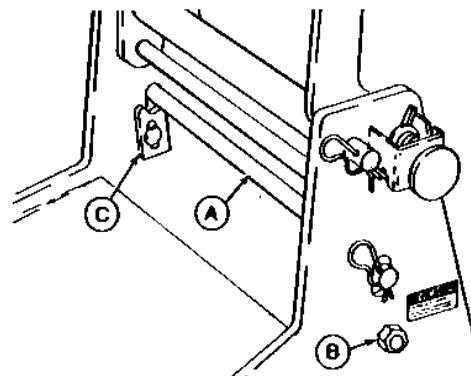

MX,INCX,G -19-21FEB91

M41975 -UN-26FEB91



Installing Rotary Broom

13. Install PTO shaft (A) on front drive shaft:

- Pull collar (B) rearward.
- Install PTO shaft on tractor PTO and release collar.
- Push and pull PTO shaft several times until coupler LOCKS.

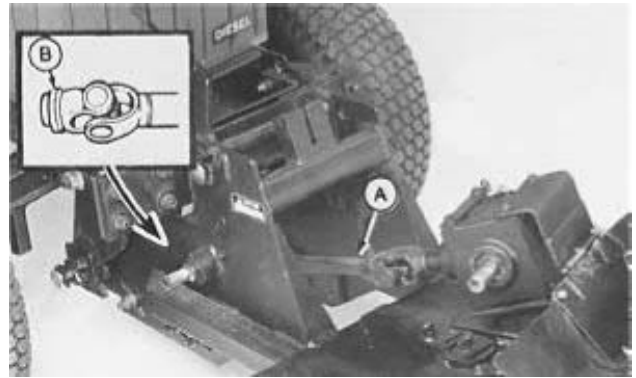

MX,INCX,H -19-21FEB91

M41791 -UN-26FEB91

N CAUTION: Escaping fluid under pressure can penetrate the skin causing serious injury. Avoid the hazard by relieving pressure before disconnecting hydraulic or other lines. Tighten all connections before applying pressure. Search for leaks with a piece of cardboard. Protect hands and body from high pressure fluids.

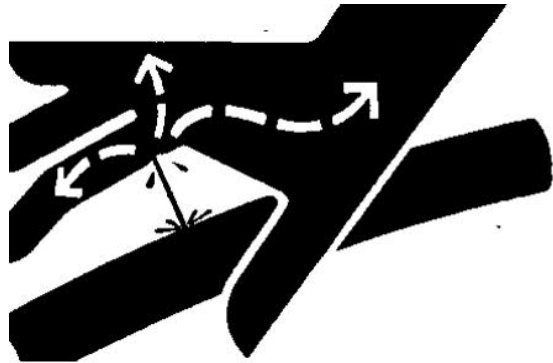

If an accident occurs, see a doctor immediately. Any fluid injected into the skin must be surgically removed within a few hours or gangrene may result. Doctors unfamiliar with this type of injury may call the Deere & Company Medical Department in Moline, Illinois, or other knowledgeable medical source.

N CAUTION: To help avoid injury from escaping hydraulic oil under pressure, relieve pressure in system by shutting off tractor and moving hydraulic control levers in both directions before installing or removing hoses.

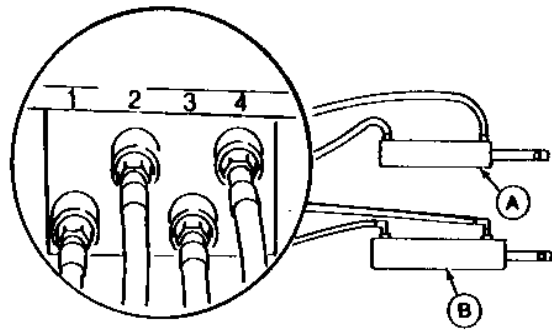

14. Install hydraulic hoses:

- Install hoses from lift cylinder (A) in tractor couplers 3 and 4. (Put hose from rod end in coupler 4.)
- Install hoses from OPTIONAL ANGLING CYLINDER (B) in tractor couplers 1 and 2. (Put hose from rod end in coupler 2.)

MX,INCX,I -19-21FEB91

-UN-23AUG88

X9811

-UN-26FEB91

M41792



Suggest:

If the above button click is invalid.

Please download this document

first, and then click the above link

to download the complete manual.

Thank you so much for reading

 Installing Rotary Broom

15. To fasten hoses—655 Tractor:

- Fasten hoses to frame with hose tie (A).
- Raise tractor hood.
- Remove left side panel.
- Fasten hoses to front panel support with hose tie (B).

IMPORTANT: DO NOT cut hose ties. Hose ties are reusable.

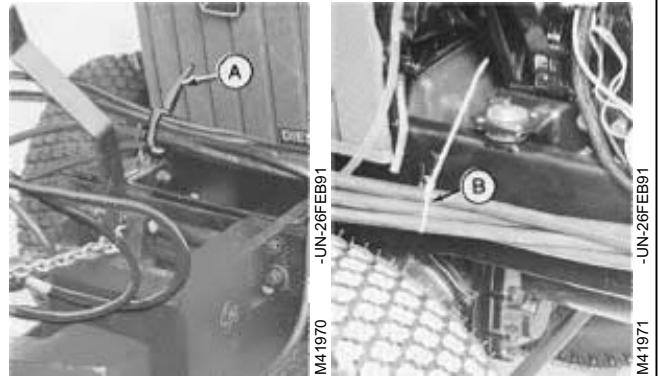

MX,INCX,J -19-21FEB91

16. To fasten hoses—755 and 855 Tractors:

- Fasten hoses to frame with hose tie (A).
- Raise tractor hood.
- Remove left side panel.
- Fasten hoses to front panel support with hose tie (B).

IMPORTANT: DO NOT cut hose ties. Hose ties are reusable.

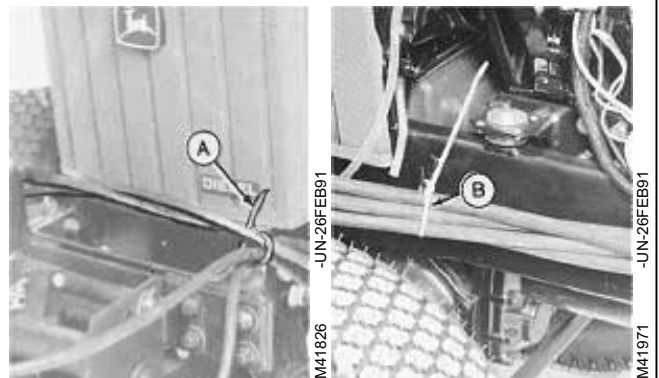

17. Lower broom to ground with tractor hydraulic lever.
Check broom position:

- Broom bristles **MUST** lightly contact ground.

See ADJUSTING LIFT HEIGHT in Operating section.



MX,INCX,K -19-21FEB91



<https://www.ebooklibonline.com>

Hello dear friend!

Thank you very much for reading.

Enter the link into your browser.

The full manual is available for immediate download.

<https://www.ebooklibonline.com>