

# 244 and 343 Quik-Thatch Corn Heads For 45, 55 and 95 Combines



JOHN DEERE

## OPERATORS MANUAL

244 and 343 Quik-Thatch Corn Heads  
For 45, 55 and 95 Combines

OMN159208 G9 English

**OMN159208 G9**

LITHO IN U.S.A.  
ENGLISH



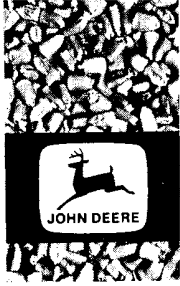

# SPECIFICATIONS

John Deere Combine Model  
Required—  
45 Serial 35001 and up  
55 Serial 69001 and up  
95 Serial 20001 and up

*NOTE: For 343 Quik-Tatch Corn Head only, 45 Combines below Serial 46001 must be equipped with front axle reinforcements. Two rear guide wheel weights must be used on 45 Combine. It is recommended that the 45 Combine be equipped with a 60- or 74-inch rear axle. All combine drive wheel tire sizes are approved except 13.6 - 26, 6-ply tires.*

Number of rows—

244. . . . .	2
343. . . . .	3

Factory setting of center-to-center distance between snapping units—

244. . . . .	38 inches
343. . . . .	30 inches

Row Widths Handled—

244. . . . .	36, 38, and 40 inches
343. . . . .	28, 30, and 32 inches

Gatherer points. . . . . Low-profile floating type, hinged above gatherer chains

Center gatherer shields . . . . Hinged, quik-removable

Number of gatherer chains per snapping unit. . . . . 2

Type of gatherer chain . . . Heavy-duty 555 endless steel roller chain (no master connecting link)

Minimum clearance between gatherer chains and ground. . . . . 1-1/4 inches

Distance gatherer chains ahead of stalk rolls. . . . . 11 inches

Gatherer chain speed . . . Adjustable for 201, 266, and 324 fpm (feet per minute)

Stalk rolls . . . . Spiral pointed, flute type, cast grey iron (2 per row unit)

Length of stalk rolls. . . . . 21-7/8 inches

Row unit drive . . . . Enclosed gear box with precision gears submerged in lubricant driven by single input hex. shaft

Deck plate adjustment. . . . . Bolt adjusted

Gatherer chain adjustment. . . . Spring loaded-self adjusting

Slip clutch. . . . . One per row unit plus cross auger drive

Conveyor from gatherers to feeder house. . . . . Full width cross auger

Trash knives. . . . . Full length one piece heat-treated steel

Trash knife adjustment. . . . . Bolt adjusted

Wheel shields. . . . . Full length adjustable type

Approximate weight of Quik-Tatch Corn Head—  
244 . . . . . 1410 lbs.  
343 . . . . . 1830 lbs.

Approximate overall length of Quik-Tatch Corn Head for storage. . . . . 10 feet

Approximate overall width of 244 Quik-Tatch Corn Head for storage—  
With wheel shields attached. . .8 feet, 4 inches  
With wheel shields removed . .6 feet, 6 inches

Approximate overall width of 343 Quik-Tatch Corn Head for storage—  
With wheel shields attached. .10 feet, 2 inches  
With wheel shields removed. .8 feet, 4 inches

Attachments for combine . . . . . Corn-cob mix

*NOTE: For other attachments available for the combine, see your John Deere dealer.*

*(Specifications and design subject to change without notice.)*



# OPERATION

## PROPER ASSEMBLY AND INSTALLATION

Proper assembly and installation of feeder house and corn head on combine will insure long life and less service problems for you. Improper assembly and installation can cause inferior work and damage to corn head, feeder house and combine. After assembly and installation, check over entire machine, being sure shields, sprockets, chains, and all other parts are properly attached. Be sure all nuts, pins, and keys are tight and cotter pins are spread.

## IN THE FIELD

Pick end rows first and then disk down end rows for a smoother ride and ease of handling. Operate combine in a lower gear until you become familiar with corn head. Pick rows of corn as they were planted so it will not be necessary to pick odd or guess rows.

After picking several rounds, stop corn head and shut off combine engine. Check all bearings for heating. Check to be sure all bolts are tight and chains are adjusted to proper tension.

## ADJUST MACHINE PROPERLY

Successful operation, quality of work, and length of life of any machine depends greatly upon proper adjustments to meet specific field conditions.

After making several rounds, check adjustments on corn head, feeder house, and combine to be sure you are getting the best possible sample of corn in grain tank.

## HARVESTING EARLY

Agricultural engineers suggest that when corn reaches 26 to 27 percent moisture, farmers with dryers can start harvesting. If you're equipped to store high moisture corn, harvesting can start when corn is at 30 percent moisture.

If corn is to be sold, it is best to wait until moisture content is down slightly below 20 percent. The main item to consider when harvesting corn early to be sold is, cost of drying and quality of corn after it is dried.

Some advantages for early harvesting are, keeping field losses low, eliminating troubles and disagreeable features that accompany frozen ground, cold weather, dried out, frozen, and rotten cornstalks.

## DRIVE CAREFULLY

The combine should travel in same direction that field was last cultivated. Drive combine carefully so corn head will stay on rows. In well standing corn, operate corn head so gatherer points are approximately 4 to 6 inches above ground. This will eliminate amount of trash taken into combine and help to eliminate possibility of gatherers picking up stones or other foreign objects that can cause damage to corn head, feeder house or combine.

Listen for slipping clutches or other unusual noises. If unit begins to plug, do not slow down combine engine. Keep engine at operating speed and decrease ground speed with variable speed control or disengage foot clutch until unit has cleared itself.

## CORN HEAD HEIGHT CONTROL

(45 Combine Serial 46001 and up, 55 Combine Serial 83001 and up, and 95 Combine Serial 35001 and up)

The combine has an adjustment to control speed of lowering corn head. If corn head is lowering at too slow or fast a rate of speed, refer to your combine operator's manual for adjusting control valve that controls speed of drop.

**<https://www.ebooklibonline.com>**

Hello dear friend!

Thank you very much for reading.

Enter the link into your browser.

The full manual is available for immediate download.

**<https://www.ebooklibonline.com>**

## OPERATE AT PROPER GROUND SPEED

The corn head as well as combine will do its best job if you operate at a moderate ground speed. Never force corn head or combine to the extent of overload. To do so may result in break-downs or trouble. Start out in a lower gear and work up until you find the proper ground speed in which to operate.

In well standing corn, forward movement of machine should be approximately same as rearward movement of gatherer chain flights, so flights gently assist in movement of stalks into stalk rolls.

If ground speed is too fast, gatherer chains push stalks forward and knock ears off stalks. If ground speed is too slow, gatherer chains jerk stalks back into unit, possibly shearing off stalks or knocking off ears of corn.

## FIELD LOSSES

During normal harvesting conditions most field losses are created by a careless operator who neglects to adjust his machine periodically.

As the season progresses, field losses will increase due to corn becoming drier and stalks rotting out. Field losses can be reduced to a minimum by keeping corn head and combine in proper adjustment. A few minutes spend each day checking corn head and combine for proper adjustments will repay you great dividends in service and long life as well as eliminating field losses.

## ESTIMATING SHELLED CORN LOSS

Count the number of kernels around a hill in a square 40 by 40 inches. Make a count several places in the field and average the count.

If you find an average of 20 kernels per square you are losing one bushel per acre; 80 kernels per square would mean a loss of four bushels per acre.

Before counting kernels per square, shake husks to remove kernels and remove all trash and leaves from the square.

## ESTIMATING EAR CORN LOSS

For 40-inch rows, mark off 133 feet (about 43 normal walking steps) along one row. For 30-inch rows, mark off 174 feet (about 58 normal walking steps) along one row. Each good sized ear (about 3/4 pound) represents one bushel of ear corn lost per acre.

Make this test several places throughout the field for a more accurate check. Be sure to kick the husks and stalks to avoid missing ears that are hidden.

To get the most accurate check on efficiency of your corn head, estimate ear corn loss before as well as during and after the field is harvested, because some ears drop off the stalks before harvest.

**CAUTION:** Never clean, lubricate, or adjust corn head, feeder house, or combine while they are in motion. Stop the combine and shut engine off. Keep hands and clothing away from moving parts.

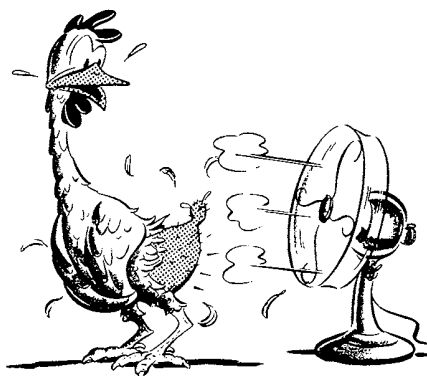

**Be Extra Cautious**  
around Moving Machinery!

R 2330

## GATHERERS

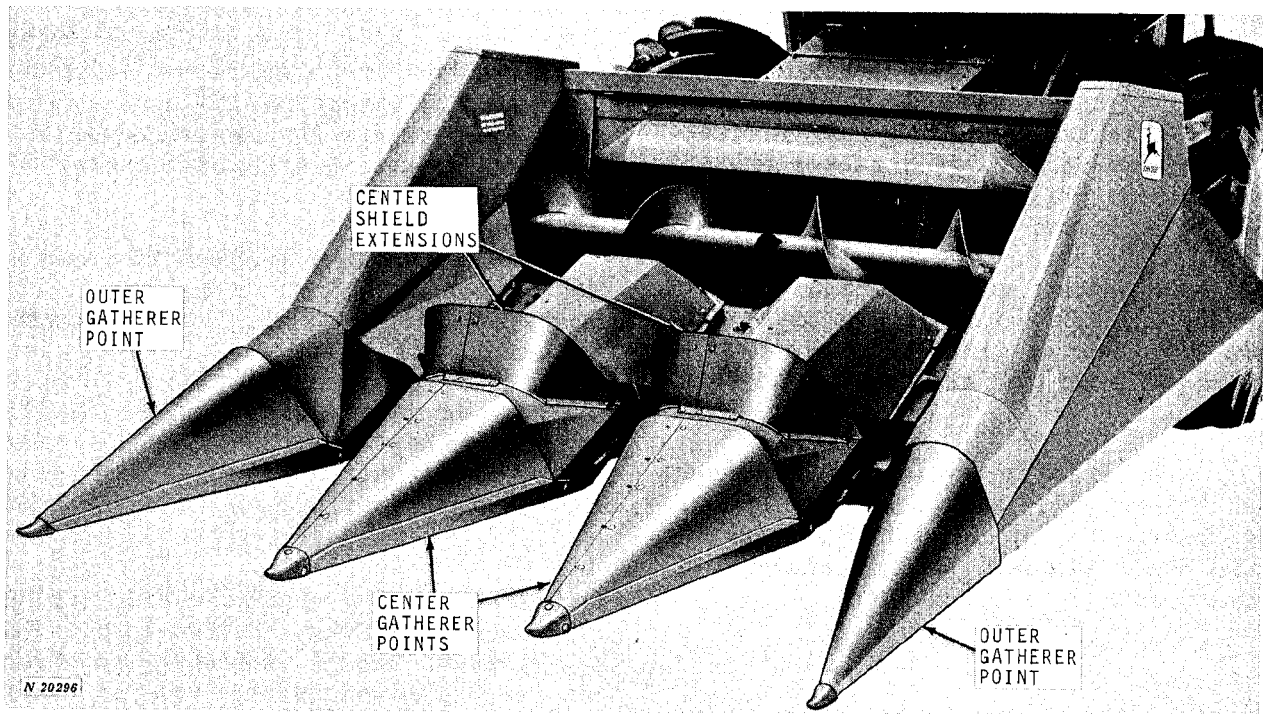

For most conditions operate front of gatherer points just touching the ground.

In muddy conditions or in snow, adjust gatherer points high enough to prevent points from scooping material into throat opening, thereby clogging the opening.

Adjust all gatherer points level with one another.

### ADJUSTING GATHERER POINTS

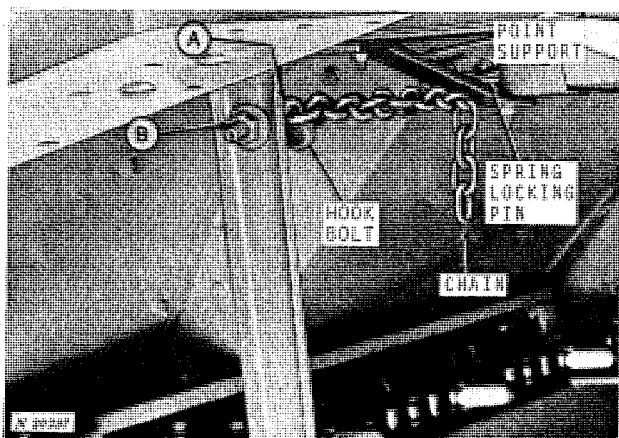

All gatherer points are hinged and will float to follow contour of ground.

Adjustments are provided for adjusting height and for leveling gatherer points.

To adjust gatherer points for desired operating height, insert chain link through point support and secure with spring locking pin.

After all gatherer points are adjusted for desired operating height, start with one of the outer gatherer points and level all other points the same.

To level gatherer points, adjust nut "A" and "B" on hook bolt.

**CAUTION:** Always lower cylinder safety stop on combine before attempting to make any adjustment on corn head when it is in raised position. See page 17.

CENTER SHIELD, CENTER SHIELD EXTENSION, AND EAR SAVERS

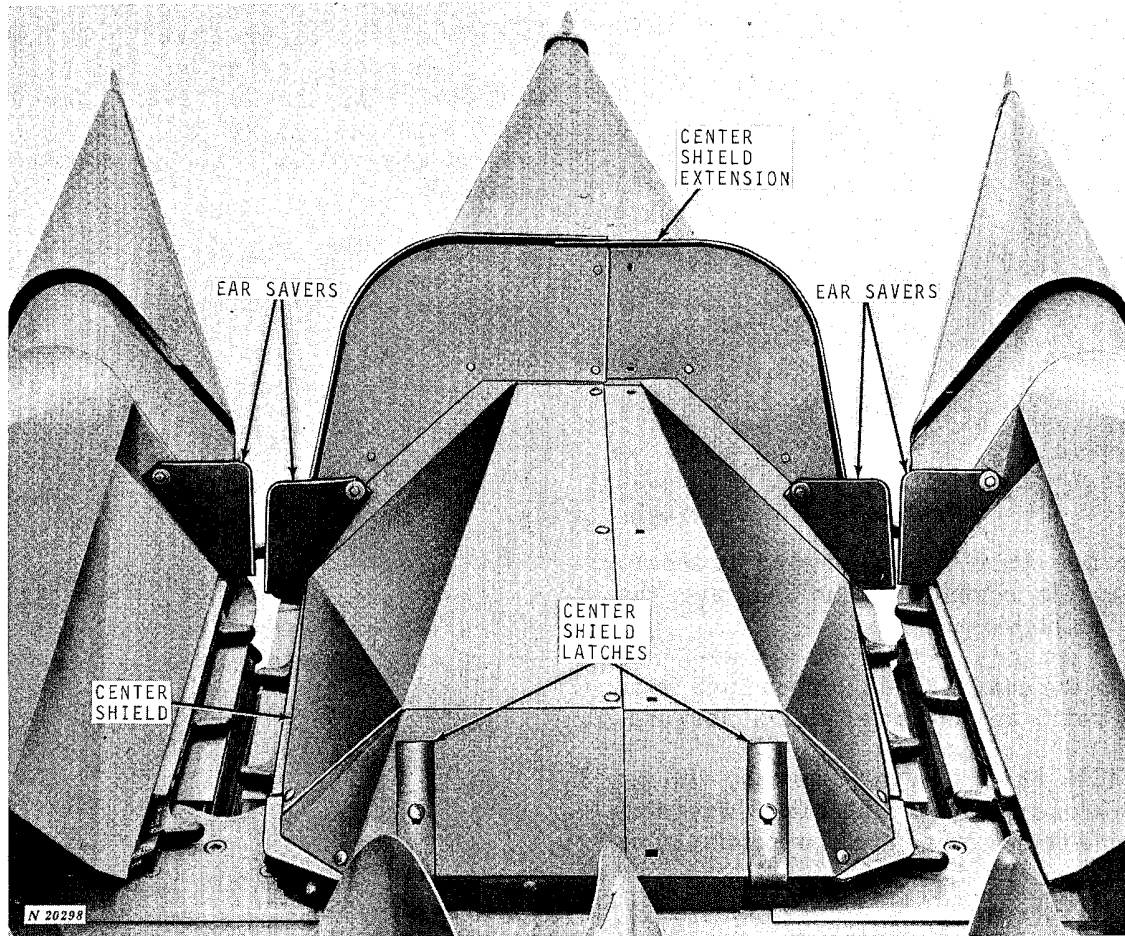

The center shield is held in place by two latches. The latches should be secured in position shown while operating.

The center shield extension is designed to catch falling ears in well-standing corn. When picking in down corn, remove the extension to prevent interference with the flow of material into the gatherer throat opening.

Flexible ear savers prevent loose ears from sliding out over the gatherer chains.

In down corn or if stalks tend to plug at the gatherer throat opening, remove ear savers.

*Adjusting Center Shield Latches*

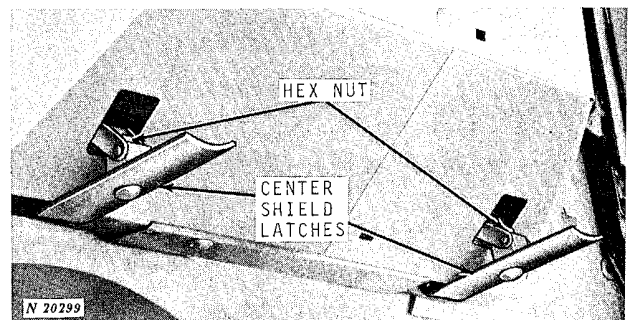

Center shield latches are slotted. To adjust, open latches and loosen hex. nut on carriage bolt that attaches latch to pivot. Adjust latches so center shield is held down tight when latches are closed.

## 8 Operation

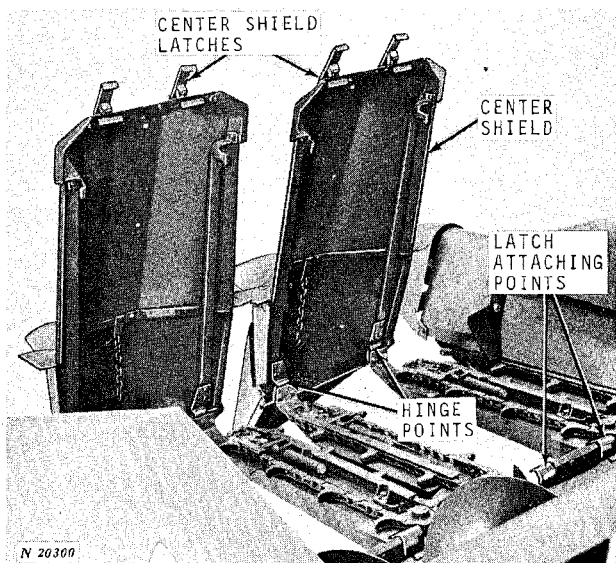

To tip the center shield forward as shown, first start the combine engine and raise the corn head as high as possible.

Release the center shield latches from their attaching points and tip center shields forward.

**CAUTION:** Never run the corn head with the center shields removed or tipped up. Always shut the combine engine off before dismantling combine.

### GATHERER CHAINS

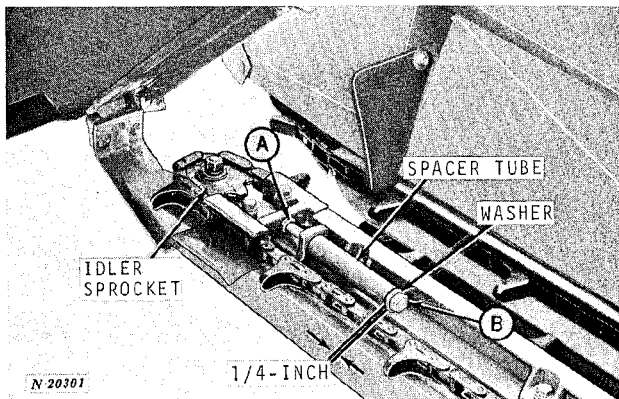

The gatherer chain tension is automatically controlled by a spring-loaded mechanism. The spring is shielded by a spacer tube that also serves as a stop to prevent the idler sprocket from retracting too far.

An adjustment is provided to compensate for normal gatherer chain wear. This adjustment should only be made after a period of time when gatherer chains wear.

To increase gatherer chain tension, loosen nut "A" and tighten bolt "B." To prevent damage to the mechanism, always maintain a 1/4-inch space between the spacer tube and washer as illustrated. The 1/4-inch space between the spacer tube and washer will allow the idler sprocket to move back if an obstruction is encountered.

### GATHERER CHAIN FLIGHTS

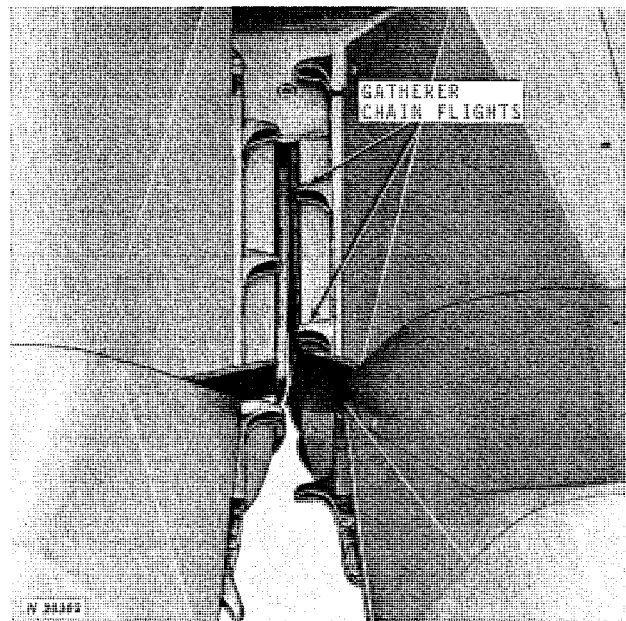

The gatherer chains are assembled at the factory with the chain flights staggered between one another as shown above.

If operating in unusual field conditions, the gatherer chain flights can be positioned opposite one another for more aggressiveness.

**CAUTION:** Be careful to avoid rocks and other obstructions in the row when running gatherers close to the ground.

See page 24 for information on servicing gatherer chains.

### DECK PLATES AND GATHERER CHAIN GUIDES

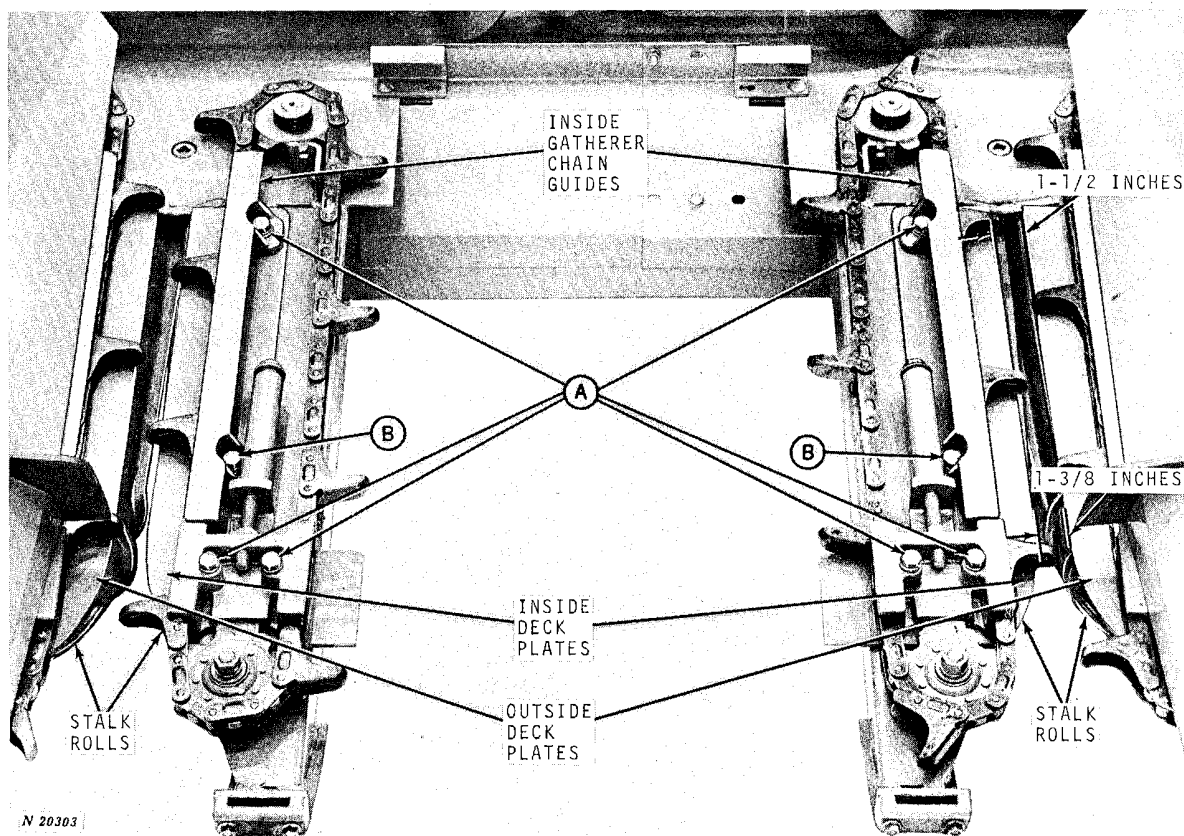

The deck plates snap ears from the stalks as the stalks are pulled down by the stalk rolls.

The corn head is shipped from factory with the deck plates spaced 1-3/8 inches apart at the front and 1-1/2 inches apart at the rear. This spacing generally covers a wide range of field conditions. However, due to different varieties of corn and varying field conditions, the deck plates can be adjusted to meet your particular condition. The size of the ears, stalks, and amount of trash taken in by the gatherers generally determines the deck plate spacing.

**IMPORTANT:** To minimize the amount of trash and stalks taken into the combine, the deck plates should be open as far as possible without causing shelling.

Gatherer chain guides support and align the gatherer chains.

#### ADJUSTING DECK PLATES AND GATHERER CHAIN GUIDES

To adjust the deck plate spacing, first tip the center shields forward as explained on page 8. Next, loosen three bolts at "A" on both the inside and outside deckplates. If the chain guides require adjusting, loosen bolt "B" at the front of the guide.

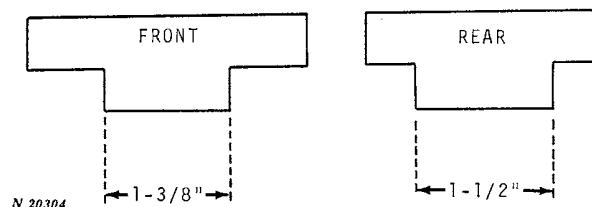

A handy gauge can be made from a set of blocks as shown above. Place blocks between deck plates and position deck plates so the gatherer chain flights will protrude over the edge of the deck plates equally on both sides.

**IMPORTANT:** Deck plates must always be spaced 1/8-inch wider apart at the rear than at the front. The center of space between the deck plates should be located over the center of space between the stalk rolls.

Adjust the gatherer chain guides in until they are just touching the gatherer chains.

Tighten bolts "A" and "B" on inside and outside guides and deck plates to 85 ft-lbs torque.

**STALK ROLLS**

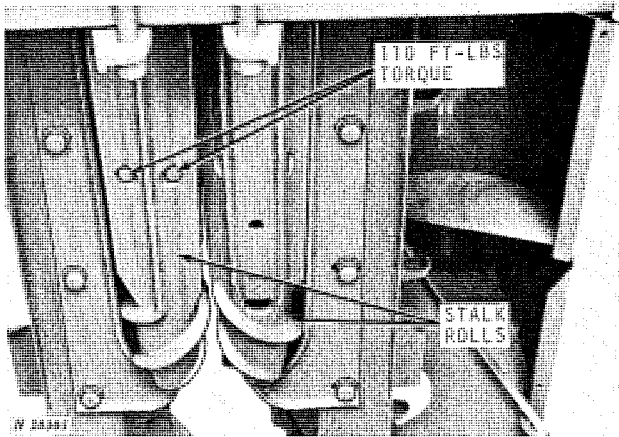

The stalk rolls pull the cornstalks down so the ears will be snapped on the deck plates.

Each stalk roll is attached to the stalk roll shaft by two special twelve-point hex. bolts. Periodically check to be sure that the bolts are tightened to 110 ft-lbs torque.

**IMPORTANT:** If bolts are replaced, use only special twelve-point hex. bolts (part number N104293) obtained from your John Deere dealer.

**TIMING STALK ROLLS**

If the gear case is removed from the corn head for service to the stalk roll shaft, the stalk rolls could be reinstalled incorrectly timed. The spring pin holes in the ends of the stalk roll shafts should be timed 90° apart to insure the stalk rolls are in time when replaced on the stalk roll shafts. See page 24 for instructions and illustration of correctly timed stalk roll shafts.

**TRASH KNIVES**

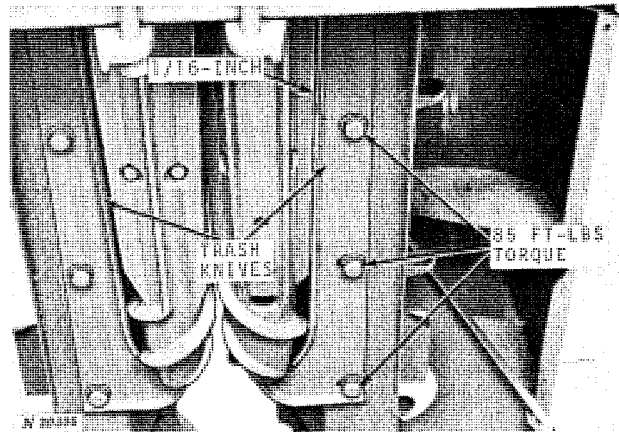

The trash knives prevent weeds and trash from wrapping around stalk rolls.

The knives should be set as close as possible to the rolls without striking the flutes.

**ADJUSTING TRASH KNIVES**

Loosen knife attaching bolts and adjust each knife to within 1/16 inch of the highest flute on the stalk roll. After adjustment is made, tighten all knife attaching bolts to 85 ft-lbs torque.

**ROW UNIT DRIVE SPROCKETS**

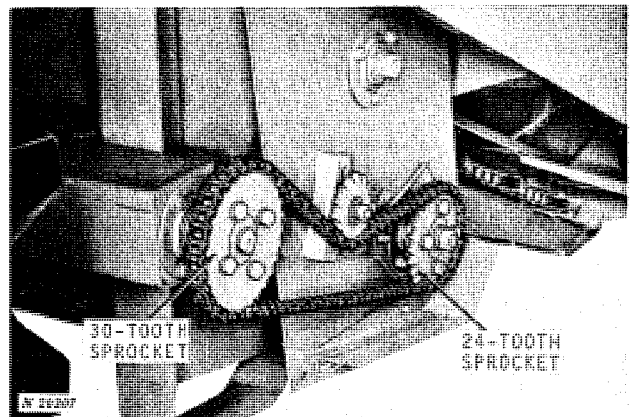

The row unit drive sprockets must be in their correct location to obtain the correct row unit drive speed.

For 45, 55, and 95 Combines, the 30-tooth sprocket must be installed on the feeder house drive shaft as shown above. The 24-tooth sprocket must be installed on the corn head as shown above. Count the number of teeth in the sprockets and make sure they are in their correct location.

If a different row unit drive speed is desired, see page 14.

ROW SPACING

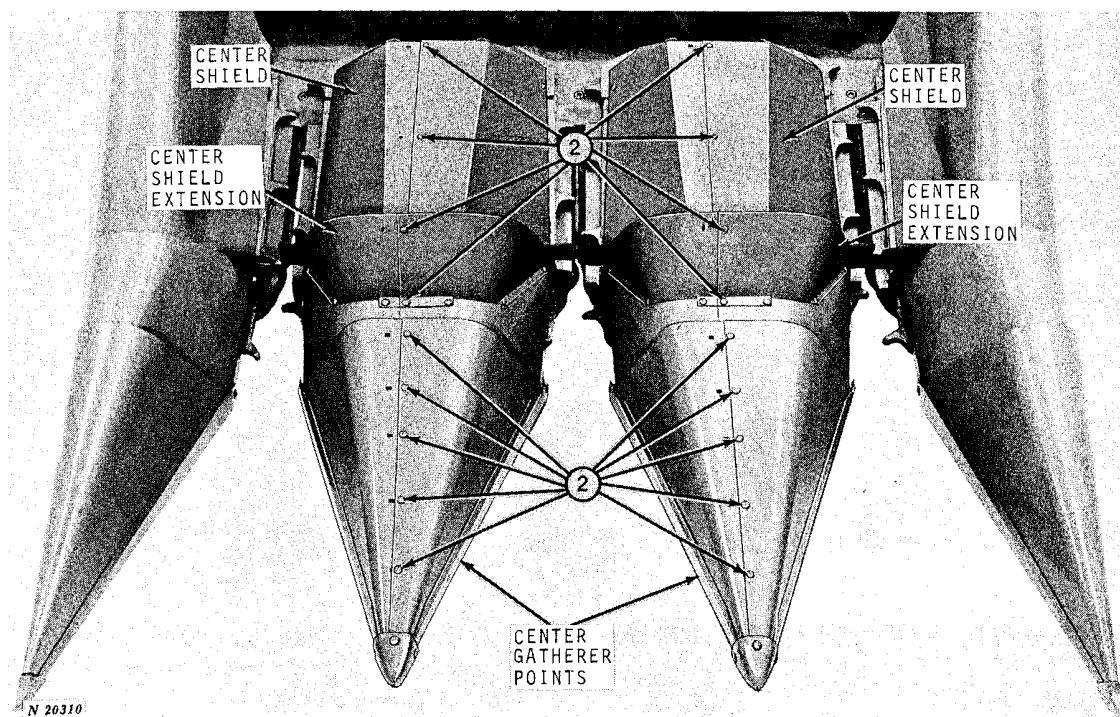

The 244 Corn Head can be adjusted to pick corn planted on 36, 38, or 40-inch rows. The 343 Corn Head can be adjusted to pick corn planted on 28, 30, or 32-inch rows. The 343 Corn Head illustrated above is set to pick corn planted on 30-inch rows.

To change row spacing, the following steps must be done:

1. Start combine engine and raise corn head as high as possible. Lower cylinder safety stop on combine to prevent corn head from lowering.

2. Remove center shields from corn head as shown on page 8. Remove all bolts attaching halves of center gatherer points, center shield extensions, and center shields together. Assemble halves of center shields, extensions, and gatherer points back together for row spacing desired.

**CAUTION:** Always be sure that cylinder safety stop on combine is lowered before working under corn head when it is in raised position. See page 17.

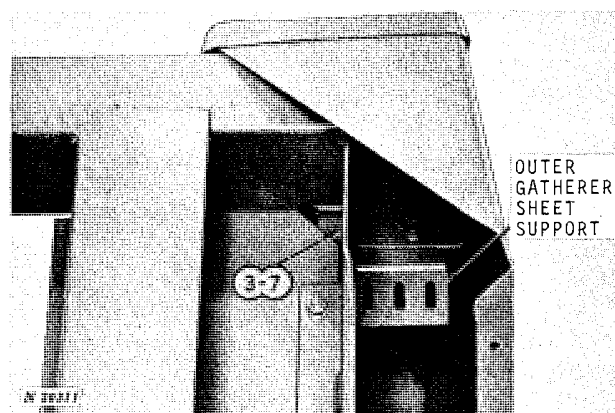

3. Remove outer gatherer sheet support attaching bolt on both outer gatherer sheet supports.

ROW SPACING—Continued

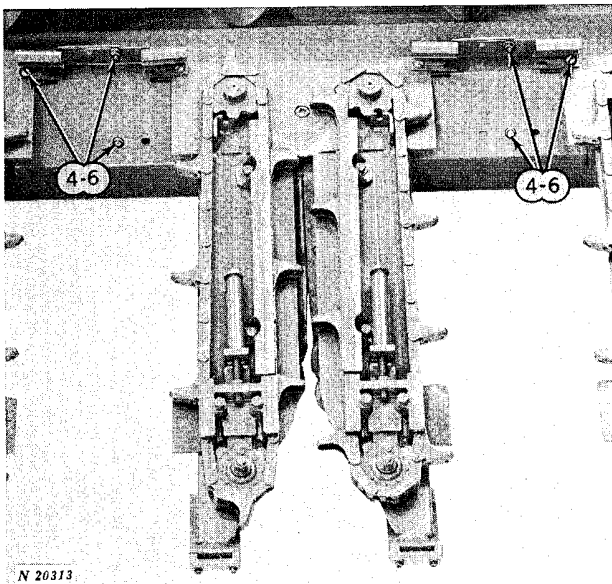
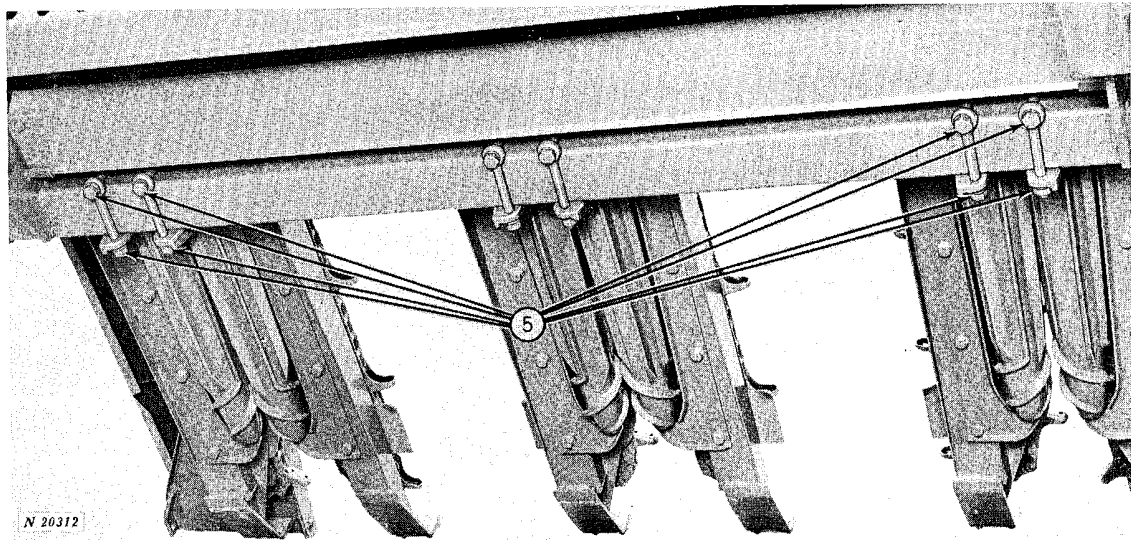

4. Remove bolts from row unit drive shields and outer center shield latch brackets.

5. The 343 Corn Head center row unit is stationary. Both row units on 244 Corn Head and only outside row units on 343 Corn Head are moved when changing row spacing. Loosen nuts on row unit attaching bolts and move units to desired row spacing. Tighten unit attaching bolts to 170 ft-lbs torque.

6. Re-install bolts in row unit drive shields and outer center shield latch brackets.

7. Re-install outer gatherer sheet support attaching bolts on both outer gatherer sheets. See page 11.

8. Install center shields, extensions, and points back on corn head. See page 7 and adjust center shield latches.

Start combine engine and engage corn head drive slowly.

SLIP CLUTCHES

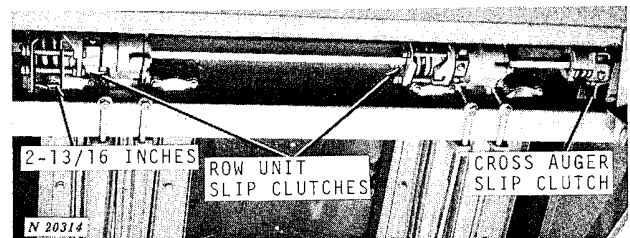

Slip clutches act as safety devices to protect the drives on the corn head. Each rowunit drive and cross auger drive have a slip clutch.

Should a clutch slip when the corn head is in operation, stop immediately, determine the cause, and correct it. All slip clutches are properly adjusted at the factory. The only time slip clutches will require adjusting is when they are disassembled for service. The length of the row unit slip clutch spring when correctly adjusted should be 2-13/16 inches.

The cross auger drive slip clutch requires no adjustment.

**IMPORTANT:** Do not tighten nuts to the point where the clutch will not slip. Make sure the two nuts used to compress the spring are jammed together.

### CORN HEAD DRIVE THROW-OUT MECHANISM

The corn head drive can be engaged or disengaged by the cutting platform throw-out lever on the 45 Combine and the cutting platform electric clutch throw-out switch on the 55 Combine Serial 78001 and up and the 95 Combine Serial 29001 and up. The drive on 55 Combine below Serial 78001 cannot be disengaged.

#### ADJUSTING TIGHTENER SHEAVE ON 45 COMBINE

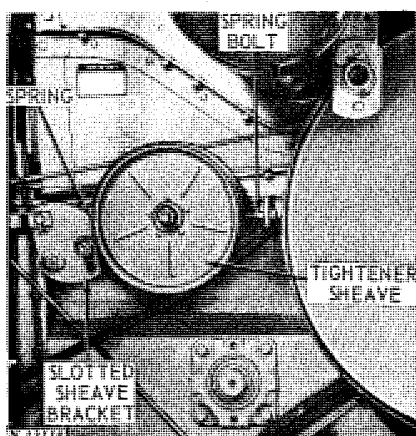

Adjust the bolt in the spring behind the sheave so the sheave is held in position when the drive is engaged.

Adjust the throw of the tightener sheave by loosening the nut in the slotted sheave bracket and moving the sheave up or down as necessary to provide proper belt tension when the feeder house drive is engaged.

#### DRIVE CHAINS

Roller drive chains should be just tight enough so they do not slap or climb sprockets.

**IMPORTANT:** When removing chain links from roller chains, be sure to reassemble chain with the closed end of spring clip in the same direction the chain will travel.

**CAUTION:** When making adjustments under corn head, always shut combine engine off and lower cylinder safety stop before making the adjustment. See page 17.

#### ADJUSTING MAIN DRIVE CHAIN ON 55 AND 95 COMBINES

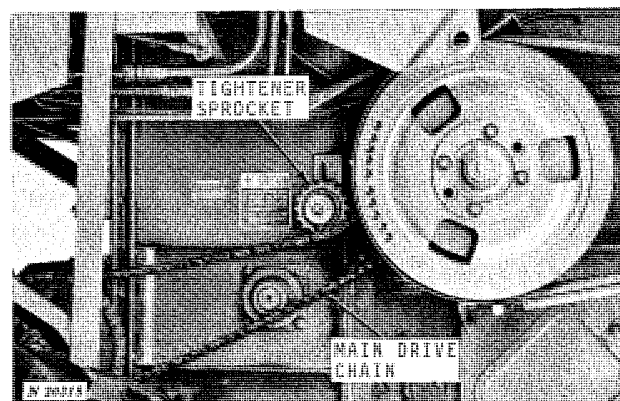

Adjust main drive chain by moving tightener sprocket on combine.

#### ADJUSTING CROSS AUGER DRIVE CHAIN

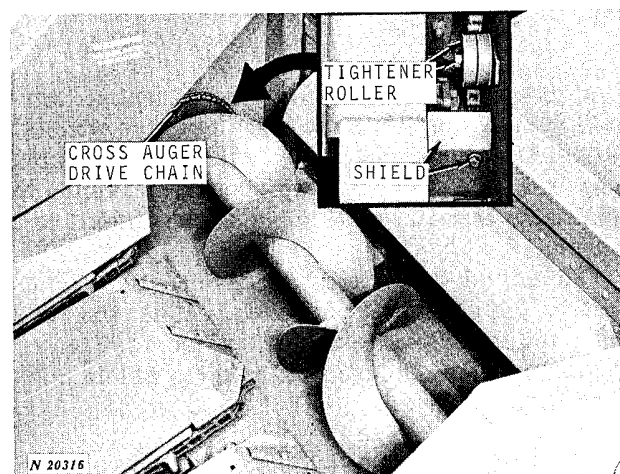

To adjust the cross auger drive chain, raise the corn head and remove the shield. Loosen the nut and adjust the tightener roller for the desired chain tension.

#### ADJUSTING ROW UNIT DRIVE CHAIN

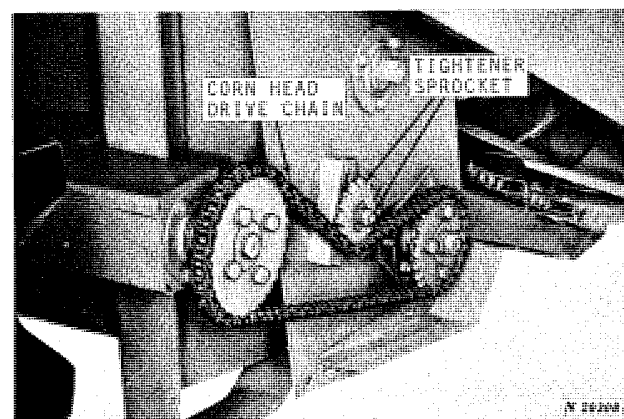

Loosen the tightener sprocket and adjust row unit driven chain for the desired tension.

**WHEEL SHIELDS**

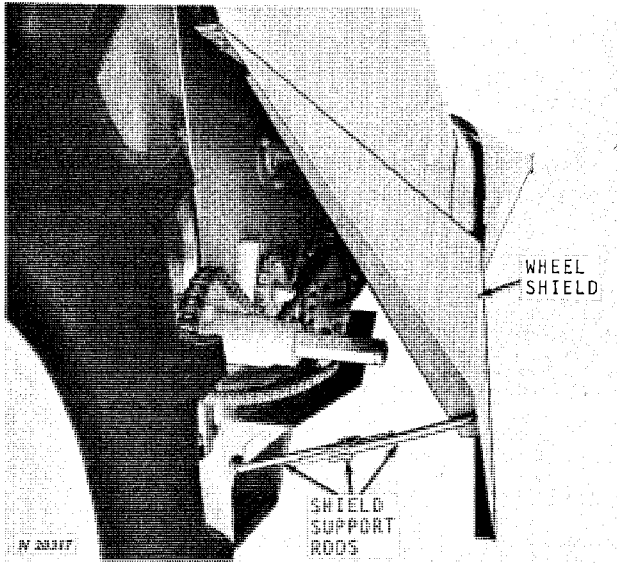

The wheel shields keep down and leaning cornstalks out of the path of the combine drive wheels. Adjust the shields as close to the combine drive wheels as possible, leaving enough clearance to let stalks and dirt pass between the shields and wheels.

To adjust wheel shields, loosen the clamp bolt on the shield support rods. Adjust the rods until the shield is positioned properly. Tighten the clamp bolt securely to hold the shield support rods in place.

**GUIDE WHEEL WEIGHTS AND FLUID**

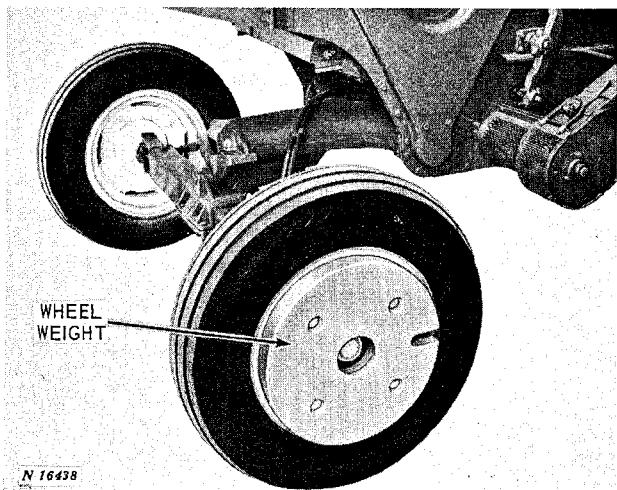

Guide wheel weights are required on the 45 Combine for use with the 343 Corn Head.

Normally, wheel weights are not necessary when using the 343 Corn Head on the 55 Combine, but they are available.

Tire Size	Pounds Weight Added
6.00-16	70
6.50-16	90
7.50-16	115
7.50-18	120

Calcium chloride solution can be added to the guide wheel tires for more weight. See your John Deere dealer for this service. The chart above lists the liquid weight each tire will hold when 75% full (filled to valve level). This solution is based on 3-1/2 pounds of calcium chloride per gallon of water. This solution will remain slush-free at -12° F.; it will freeze solid at -52° F.

**CORN HEAD DRIVE SPEEDS**

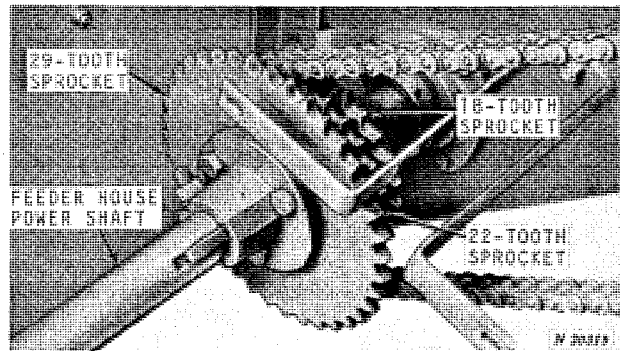

The corn head drive speed can be changed by one of three feeder house power shaft drive sprockets. These sprockets are located on the left-hand side of the feeder house.

**IMPORTANT:** The feeder house power shaft speed is determined by the combine beater speed. The 45 Combine beater speed should be 650 rpm and the 55 and 95 Combine beater speed should be 680 rpm to obtain the power shaft speed given in the chart below. Check the combine beater speed first before changing the feeder house power shaft speed.

Sprocket (Number of Teeth)	Power Shaft Speed	Approximate Combine Travel Speed
18	470 rpm	3-3/4 mph
22	386 rpm	3 mph
29	292 rpm	2-1/4 mph



**Suggest:**

**If the above button click is invalid.**

**Please download this document**

**first, and then click the above link**

**to download the complete manual.**

**Thank you so much for reading**

### COMBINE CYLINDER SPEEDS

The combine cylinder speed is an important factor in harvesting corn. Any of the cylinder speeds shown in the charts below can be used. The charts list beater and cylinder sprockets required to obtain desired cylinder speed. These sprockets are available from your John Deere dealer. The charts also list total number of cylinder drive chain links required with each sprocket combination. When changing sprocket combinations, add or remove chain links as required.

Sprockets On Cylinder Shaft (Number of Teeth)	Sprockets On Beater Shaft (Number of Teeth) 55 Combine											
	24T		27T		28T		30T		35T		42T	
	Cyl. rpm	Chain Links Req'd.	Cyl. rpm	Chain Links Req'd.	Cyl. rpm	Chain Links Req'd.	Cyl. rpm	Chain Links Req'd.	Cyl. rpm	Chain Links Req'd.	Cyl. rpm	Chain Links Req'd.
27T	604	74										
28T	583	75										
30T	544	76										
32T	510	77	574	79	600	79						
35T	466	78	525	80	544	80	583	81				
38T	429	79	483	81	500	81	540	82				
42T	388	82	437	83	453	84	486	85	566	87		
48T	340	85	382	86	400	87	425	88	495	90	593	93
59T	277	91	311	92	323	93	346	94	403	96	484	99

Sprockets (Number of Teeth) 45 Combine			
Cylinder RPM	Beater Teeth	Cylinder Teeth	No. Chain Links Req'd.
575	23	26	61-67
547	16	19	55-62
547	32	38	72-75
536	19	23	58-64
528	26	32	66-71
515	38	48	80-82
476	19	26	59-66
467	23	32	64-69
452	16	23	57-63
445	26	38	69-73
433	32	48	78-80
418	38	59	86-87
400	16	26	58-65
393	23	38	68-72
386	19	32	63-68
352	26	48	75-77
352	32	59	84-85
325	16	32	61-67
325	19	38	66-70
312	23	48	74-76
286	26	59	82-83

The recommended cylinder speed for most corn harvesting conditions is approximately 483 rpm (revolutions per minute).

The main factor in determining what cylinder speed to use is the moisture content of corn. There is no advantage in operating the cylinder any faster than necessary. For extremely dry corn, the combine will do a completely satisfactory job with a cylinder speed of approximately 277 rpm. When combining wet corn, better results will be obtained by operating the cylinder up to 604 rpm. Never operate the cylinder faster than 604 rpm when combining corn.

Low moisture corn will have less tendency to crack when a slower cylinder speed is used. A fast cylinder speed will do a better job of stripping high moisture corn off the cob than a slow cylinder speed.

Always operate the combine at full throttle. The cylinder speed is determined by the sprocket arrangement on beater shaft and on cylinder shaft. Never try to change cylinder speed by adjusting the throttle.

**<https://www.ebooklibonline.com>**

Hello dear friend!

Thank you very much for reading.

Enter the link into your browser.

The full manual is available for immediate download.

**<https://www.ebooklibonline.com>**