



205 CORN ATTACHMENT



JOHN DEERE

OPERATORS MANUAL 205 CORN ATTACHMENT

OMN97706 J4 English



OMN97706 J4

LITHO IN THE U.S.A.
ENGLISH

TO THE PURCHASER

This manual contains useful information on how to operate your new John Deere 205 Corn Attachment.

A corn attachment must be built to handle a wide range of conditions. Average conditions can be handled by the 205 Corn Attachment with regular equipment. Unusual conditions can be handled by installing special equipment.

Field conditions vary from year to year, from day to day, and even from hour to hour. Different varieties of corn present widely different picking problems. A careful study of adjustments on your corn attachment and what they accomplish under varying conditions will allow you to reap many benefits and economies that a corn attachment can provide.

Your new corn attachment will do quality work in direct proportion to the care you use in operating it. Operate and service the attachment according to the instructions in this manual.

If you need information not covered in this manual, see your John Deere dealer. He has the latest information on how to get the best service from your corn attachment and can give you prompt service in the field or in his shop.

When in need of parts, go to your John Deere dealer. He carries genuine John Deere parts for your 205 Corn Attachment.

Be prepared to give him the serial number of your corn attachment and the year purchased. This information should be recorded below on this page as soon as you have received your corn attachment.

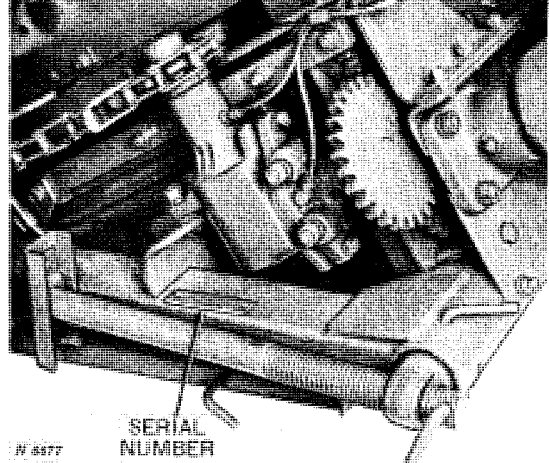

Serial Number.....

Date Purchased.....

You will find the serial number plate on the left-hand main frame as illustrated above.

CONTENTS

	<i>Page</i>		<i>Page</i>
SPECIFICATIONS	2	Combine Beater Speed.....	16
OPERATION	3-16	Suggested Combine Settings for Combining Corn.....	16
General Instructions.....	3-4	Special Equipment.....	16
Field Losses.....	4	LUBRICATION	17-19
Wheel Shields.....	4	TROUBLE SHOOTING	20-23
Gatherers.....	5-7	SERVICE	24-25
Gatherer Points.....	5	REMOVING CORN ATTACHMENT	26-29
Ear Saver.....	5	Preparing for Storage.....	26
Gatherer Chains.....	6-7	Removing from Combine.....	26
Stalk Rolls.....	8	Preparing 40 or 42 Combine for Small Grain	27
Stalk Roll Remote Control.....	8	Preparing 45 Combine for Small Grain....	28-29
Timing Stalk Rolls.....	9	INSTALLING CORN ATTACHMENT ... 29-41	
Trash Knives.....	9	Preparing Attachment for Use.....	29
Deck Plate and Snapping Bar.....	10	Preparing 40 or 42 Combine for Corn.....	30-32
Conveyor Augers and Trash Mover.....	11	Preparing 45 Combine for Corn.....	33-40
Roller Chains.....	12	Mounting Corn Attachment on Combine.	41
Slip Clutch.....	12	ASSEMBLY	42-48
Safety Suggestions.....	13		
Safety Stand.....	13		
Concave-to-Cylinder Spacing.....	14		
Combine Cylinder Speeds and Sprockets..	15		

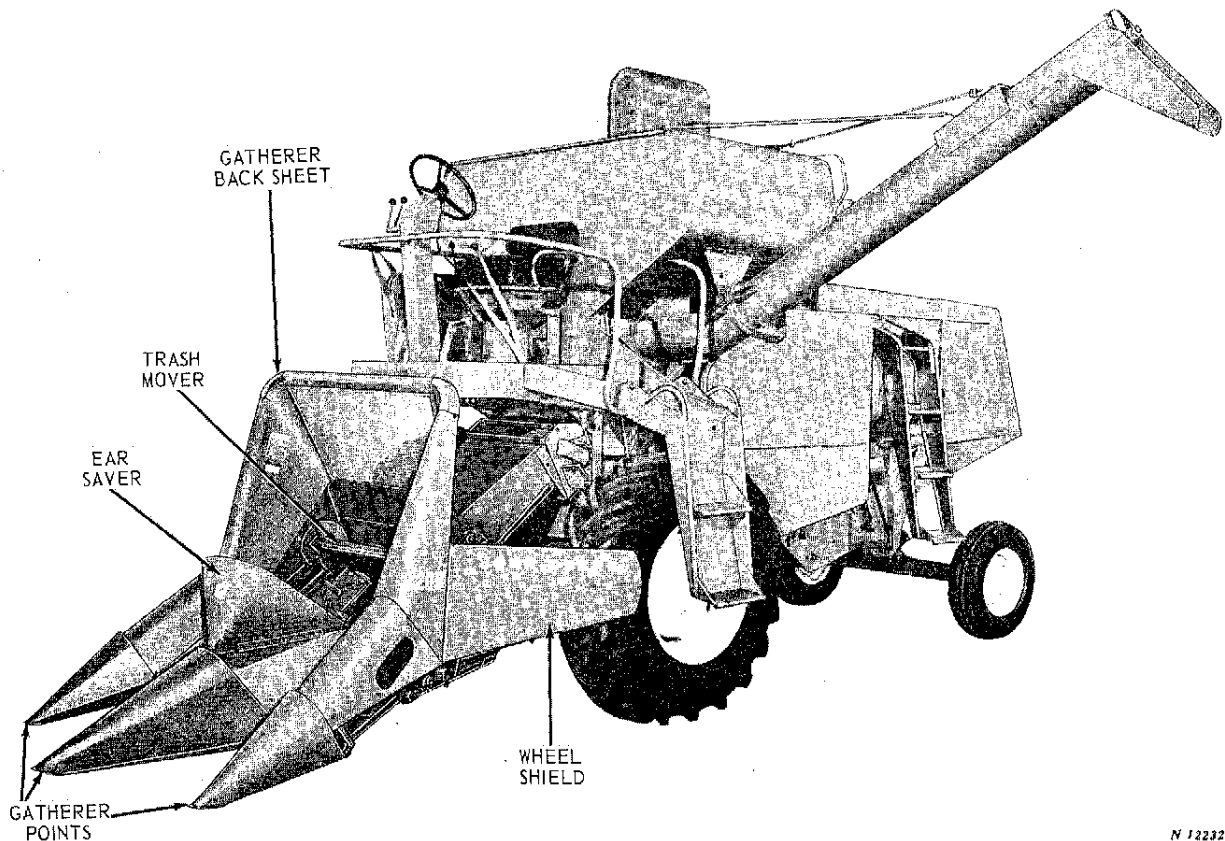

N 12232

John Deere 205 Corn Attachment on 45 Self-Propelled Combine

<https://www.ebooklibonline.com>

Hello dear friend!

Thank you very much for reading.

Enter the link into your browser.

The full manual is available for immediate download.

<https://www.ebooklibonline.com>

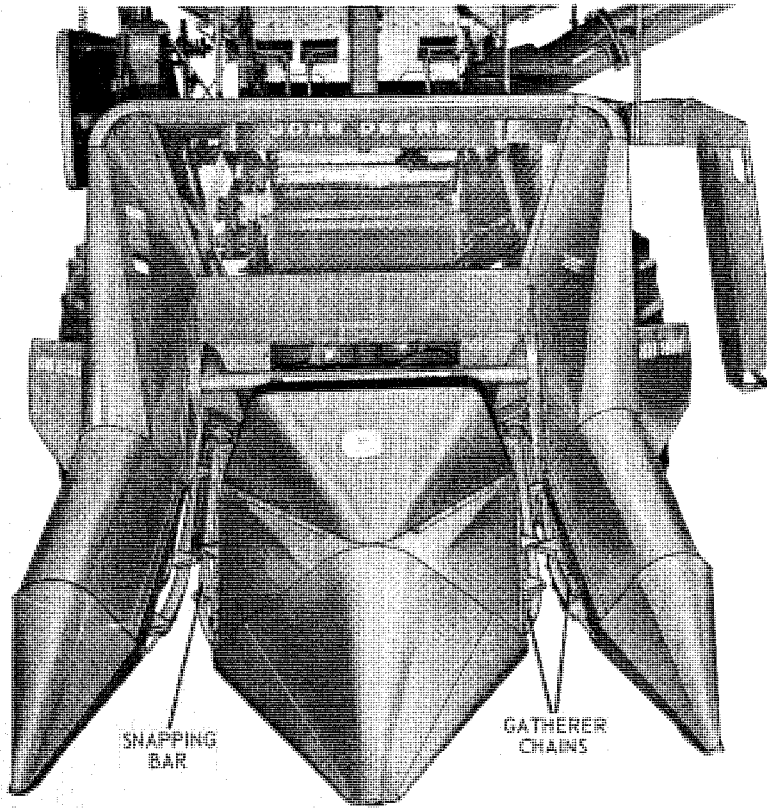

N 12233

John Deere 205 Corn Attachment on 40 Self-Propelled Combine

SPECIFICATIONS

Number of rows.....	2	Conveyor from gatherers to combine cylinder.....	Augers
Center-to-center distance between snapping units.....	39 inches	Over-all width (storage).....	5 feet 4-1/2 inches
Row widths handled.....	38 to 42 inches	Over-all width with wheel shields	8 feet 6 inches
Gatherer points.....	Hinged above gatherer chains	Over-all length (storage).....	9 feet 2 inches
Number of gatherer chains per snapping unit.....	2	Over-all length including 40 Combine.....	22 feet 10 inches
Type of gatherer chains.....	Steel roller chain	John Deere Combine required..	40, 42, or 45
Minimum clearance between gatherer chains and ground...	0 inch and up	Approximate shipping weight...	1150 lbs.
Distance gatherer chains ahead of fluted stalk rolls.....	8 inches		
Length of fluted stalk rolls.....	27-1/2 inches		
Fluted stalk roll adjustment....	Adjusting nut		
Snapping bar adjustment.....	Adjusting slots		

SPECIAL EQUIPMENT

Drive Chain Shields
 Auger Housing Divider
 Stalk Roll Remote Control Lever
 Wheel Shield for John Deere 42 Combine
 Platform Guard for 40 Combine

(Specifications and design subject to change without notice.)

OPERATION

PROPER INSTALLATION

Be sure the corn attachment is properly installed on the combine. Improper installation can cause inferior work and damage to the corn attachment and combine. After corn attachment is completely installed, check over the entire machine, being sure shields, sprockets, chains, and all other parts are properly attached, and adjustments made as illustrated. Be sure all nuts, pins, and keys are tight and cotter pins are spread.

BEFORE OPERATION

Before putting the corn attachment in the field for the first time, lubricate it thoroughly and operate at slow speed for ten minutes, making sure that all parts are working freely. If there is no binding or heating, run at fast idle speed for approximately five minutes, if this has not already been done by the dealer. Next, go over the entire machine to be sure that all bolts are tight, and that lubricant is reaching all bearings. Be sure to check the tension of all chains.

IN THE FIELD

Take pride in doing the best work possible under all conditions. Follow the rows carefully; set gatherer points and tilt machine to pick up the down and leaning stalks; set stalk rolls so corn is not mutilated or shelled excessively; and adjust for damp or dry corn. Adjustments are provided on the machine to meet these conditions.

ADJUST MACHINE PROPERLY

Successful operation, quality of work, and length of life of the corn attachment depend greatly upon adjusting the corn attachment and combine to meet your specific field conditions, and on proper lubrication.

After several rounds, check the adjustments to be sure you are getting the best possible sample of corn in the grain tank.

HARVEST EARLY

Early harvesting, before corn gets too dry, is one way to keep field losses low. Agricultural engineers suggest that when early maturing corn reaches 26 to 27 percent moisture, farmers with dryers can start harvesting. If you're set up to store high moisture corn, harvesting can start when corn is at 30 percent moisture.

If you plan to sell or store shelled corn, moisture should not exceed 12-1/2 percent. Corn having more than 12-1/2 percent moisture will spoil in storage.

DRIVE CAREFULLY

The combine should travel in the same direction that the field was last cultivated.

Listen for slipping clutches and watch for deep furrows, rocks, or other obstructions which the gatherer points may strike.

Drive the combine carefully so the corn attachment will stay on the rows. Raise the corn attachment when crossing the end of the field.

If the unit begins to plug, do not slow down the combine engine. Keep the engine at operating speed and decrease the ground speed with the variable speed control or by disengaging the foot clutch until the unit has cleared itself.

Do not use a cornstalk or stick to clean stalk rolls of an ear or trash while corn attachment is operating. If for any reason the corn attachment should become clogged, stop the combine engine and then remove obstacle. Keep hands completely away from stalk rolls while machine is in motion.

Never clean, lubricate, or adjust corn attachment or combine while either is in motion.

Be sure to stop the combine engine before making any adjustments.

CHECK GROUND SPEED

In average conditions, the corn attachment will do best work when traveling at a moderate rate of speed.

In well-standing corn the forward movement of the machine should be about the same as the rearward movement of the gatherer chain flights, so the flights gently assist the stalks into the stalk rolls.

If ground speed is too fast, the gatherer chains push stalks forward and knock off the ears. If ground speed is too slow, the chains jerk the stalks into the rolls, possibly breaking the stalks or knocking off ears.

FIELD LOSSES

As the season progresses, field losses will increase. The corn dries out causing more shelling, and stalks become brittle causing more ear drop.

However, these losses can be reduced to a minimum by keeping your machine in proper adjustment, following the rows carefully, and picking at the proper speed according to yield and field conditions.

ESTIMATING SHELLED CORN LOSS

Count the number of kernels around a hill in a square 40 by 40 inches. Make a count several places in the field and average the count.

If you find an average of 20 kernels per square you are losing one bushel per acre; 80 kernels per square would mean a loss of four bushels per acre.

Be sure to clear away all husks and leaves and shake any remaining kernels from husks.

ESTIMATING EAR CORN LOSS

Mark off 133 feet (about 43 normal walking steps for an adult man) along one row. Each good sized ear (about 3/4 pound) represents one bushel of ear corn lost per acre.

Make the test several places throughout the field for a more accurate check. Be sure to kick the husks and stalks to avoid missing ears that are hidden.

To get the most accurate check on the efficiency of your corn attachment, estimate the ear corn loss before as well as during and after the field is harvested because some ears drop off the stalks before harvest.

WHEEL SHIELDS

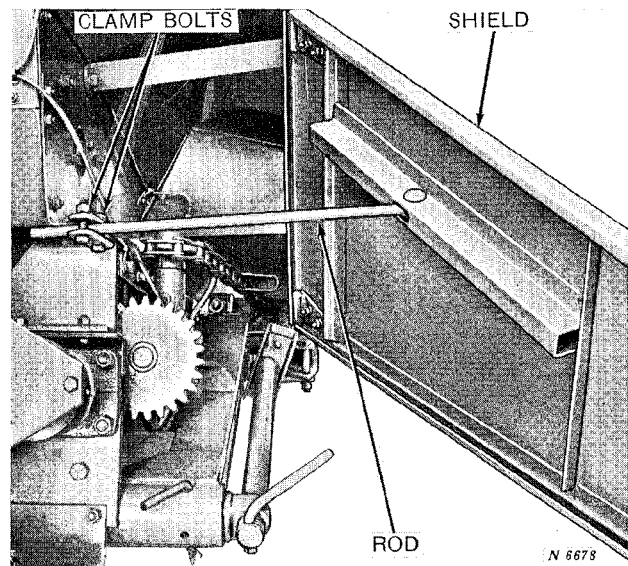

On the John Deere 40 and 45 Combine, the corn attachment wheel shields must be adjusted so they do not come in contact with the combine wheels.

Adjust the shield by loosening the clamp bolts and sliding the rod in or out to the desired setting.

It is important that the shield setting be checked daily because the cornstalks brushing the shield may force the shield into the combine tire.

**It Hurts
to get
HURT!**



R 2235

GATHERERS

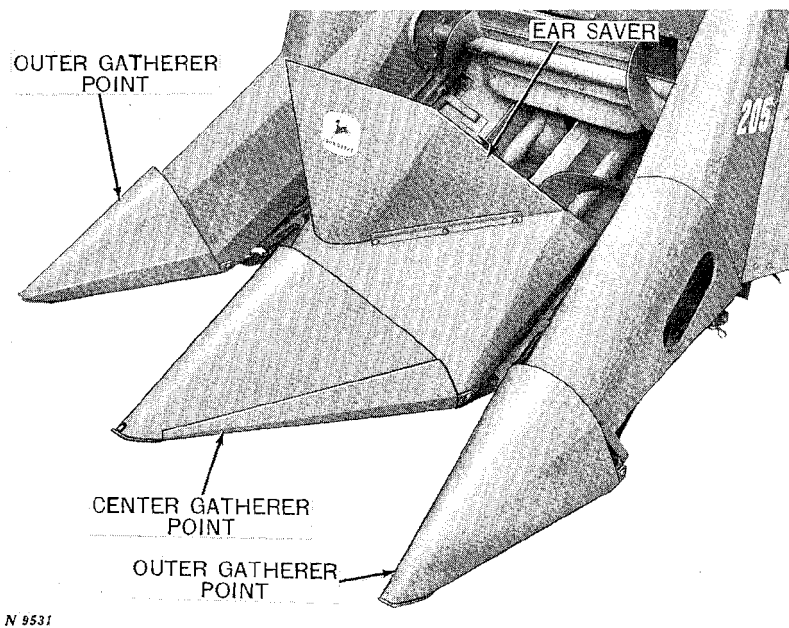

N 9531

GATHERER POINTS

The gatherer points are hinged to follow the contour of the ground.

They can be raised and locked in any one of a number of positions with bolt "A." To obtain a fine adjustment reposition bolt "B" in the other hole in the back of the strap.

Make sure the spring on the strap is positioned just below the spring bumper to cushion the corn attachment against ground shocks.

When picking corn, have the gatherer points just touching the ground. In muddy conditions or in snow, raise and lock the gatherer points high enough to prevent them from scooping material into the throat opening.

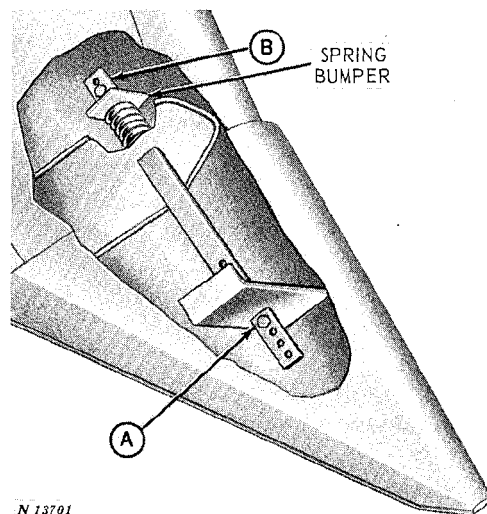

N 13791

EAR SAVER

The ear saver is designed to catch falling ears in well-standing corn. When picking in down corn, the ear saver can be removed if it is interfering with the flow of cornstalks into the unit.

BE SAFE

It pays to be careful,

It costs to be careless!

GATHERER CHAINS

The gatherer chains run well beyond the points of the stalk rolls to pull corn stalks into the unit. The chains can be run touching the ground if necessary to bring low hanging ears and down stalks into the stalk rolls.

The gatherer chains should be lubricated at frequent intervals (except in dusty conditions) with SAE 30 motor oil.

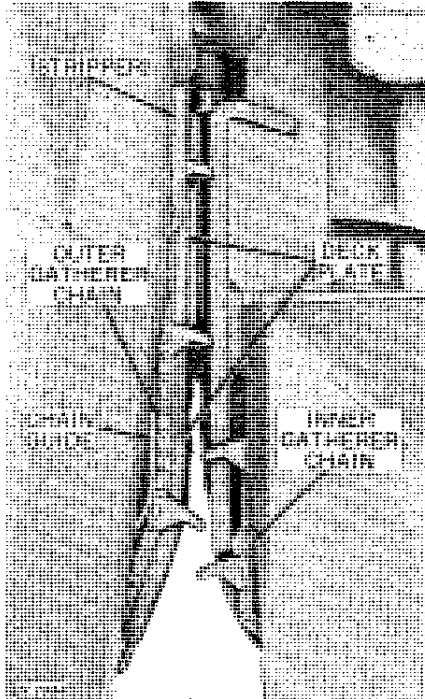

ADJUSTING STRIPPER AND UPPER GATHERER CHAIN GUIDE

Stripper

The stripper is used to strip material from the gatherer chain and to hold the chain down.

It should be adjusted so there is about 1/8-inch clearance between the stripper and the chain. Make the adjustment by loosening nuts "A" and moving stripper in the slots.

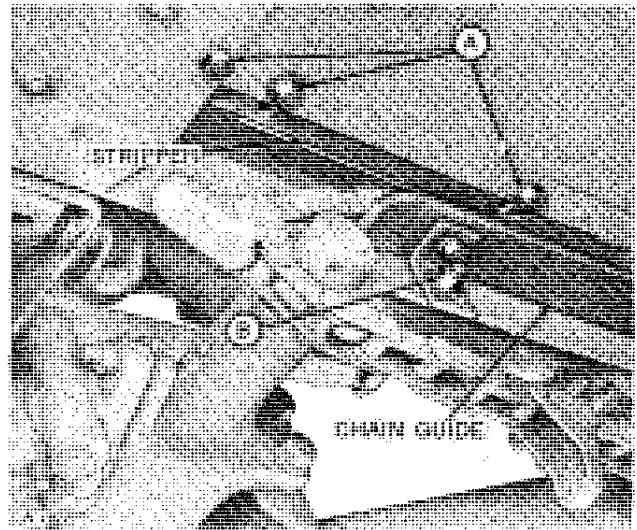

Chain Guide

In extremely wet or weedy conditions the stalk rolls will perform more efficiently if the upper chain guide is moved back away from the stalk rolls.

In exceptionally trashy conditions better picking will result if the upper chain guide is adjusted closer to the stalk rolls so the gatherer chain flights will carry the trash back to the snapping section of the stalk rolls.

Adjust chain guide by loosening nut "B" and moving chain guide.

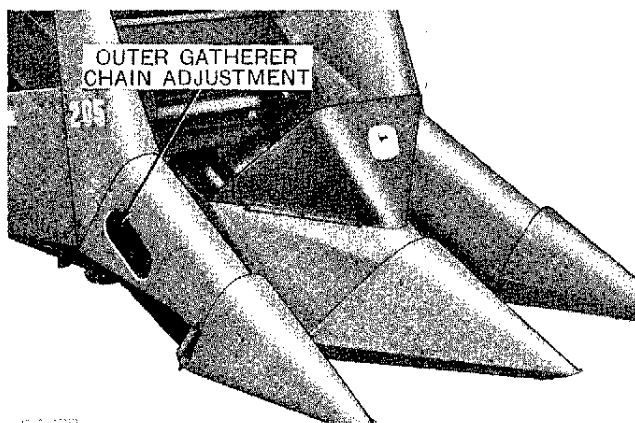

be careful.....
avoid accidents

ADJUSTING OUTER GATHERER CHAIN

N 1878

A hole is provided in the outer gatherer sheet for access to the outer gatherer chain tightener, chain guide and deck plate.

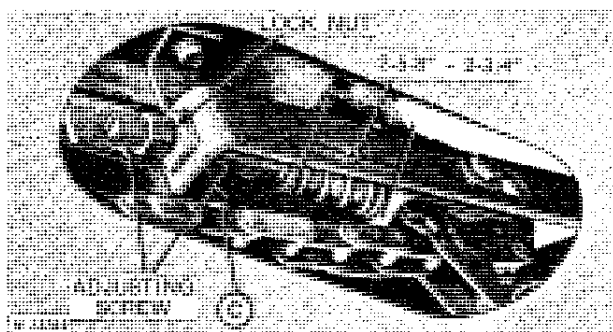
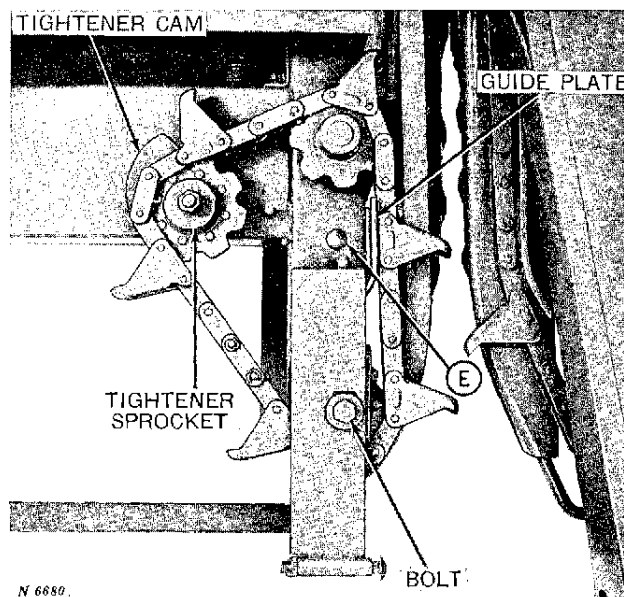
**ADJUSTING INNER GATHERER CHAIN**

N 6680

Chain Tightener

To adjust the inner gatherer chain loosen the nut on the tightener sprocket and move tightener cam until the bolt is approximately in the center of the square slot. This allows the spring to keep a constant tightening pressure on the chain idler sprocket. (Center shield removed for purposes of illustration.)

Chain Tightener

To adjust outer gatherer chain, loosen lock nut and turn adjusting screw until spring length is 2-5/8 to 2-3/4 inches. Tighten lock nut to maintain the setting.

Chain Guide

In extreme conditions if the gatherer throat is clogging, the lower gatherer chain guide can be moved closer to the stalk roll points to drag the material past the throat.

Adjust the chain guide by loosening the nut on bolt "C" and sliding the chain guide in or out.

Chain Guide

The guide can be moved out to obtain more aggressive action of the gatherer chain. To adjust chain guide, loosen nut on bolt "E" and slide guide until desired adjustment is obtained. Tighten nut after adjusting.

Keeping your equipment in proper adjustment will help to keep it operating efficiently and economically.

STALK ROLLS

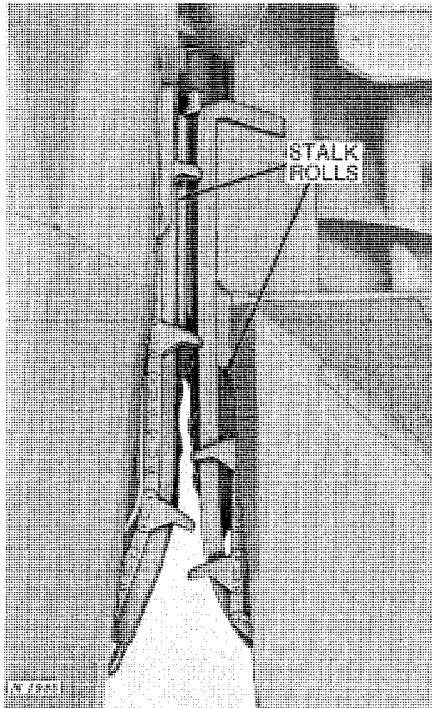

The fluted stalk rolls pull the corn stalks down so ears will be snapped at the snapping bar.

They have aggressive lugs and a pair of cams at the upper end to force tangled and delayed stalks through the upper end of the rolls.

The points of both rolls are carried close to the ground and are spiral ribbed. They assist in augering the corn safely into the rolls.

ROLL SPACING ADJUSTMENT

As a general rule, run the rolls as close together as possible without breaking the cornstalks. The supports for the lower bearings on the inner and outer rolls should be kept tight to minimize roll shake. Tighten bearing support nuts to a minimum of 85 ft-lbs of torque.

The spacing of the stalk rolls is changed by an adjusting nut that moves the outer roll in or out.

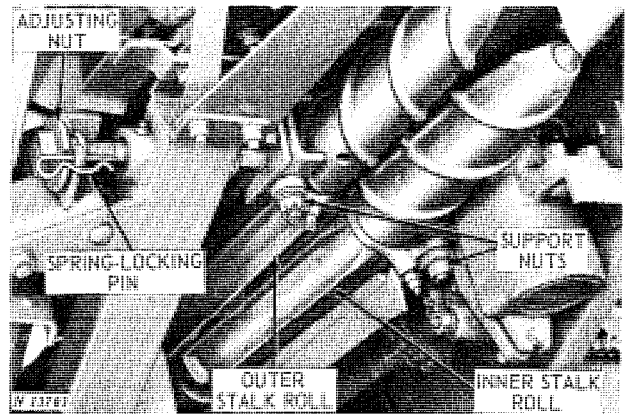

To adjust the roll spacing, remove the spring-locking pin and turn the adjusting nut clockwise to open the rolls or counter-clockwise to close the rolls.

STALK ROLL REMOTE CONTROL

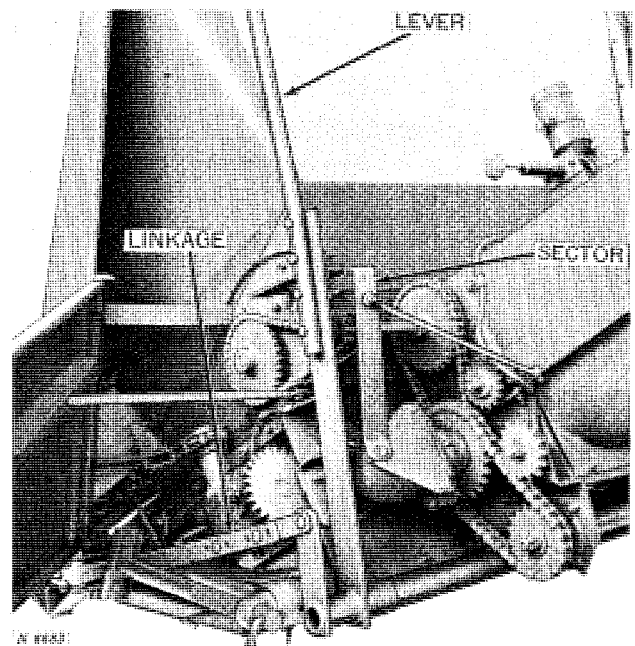

The stalk roll remote control lever allows the operator to adjust the spacing of the stalk rolls from the combine platform.

A wide range of holes is provided in the attaching linkages in order to obtain the desired setting of the lever in the sector.

Under normal conditions, when the lever is pulled all the way back, the stalk rolls should be closed. If not, change the length of the linkage until the stalk rolls are closed when the lever is in the rear position.

TIMING STALK ROLLS

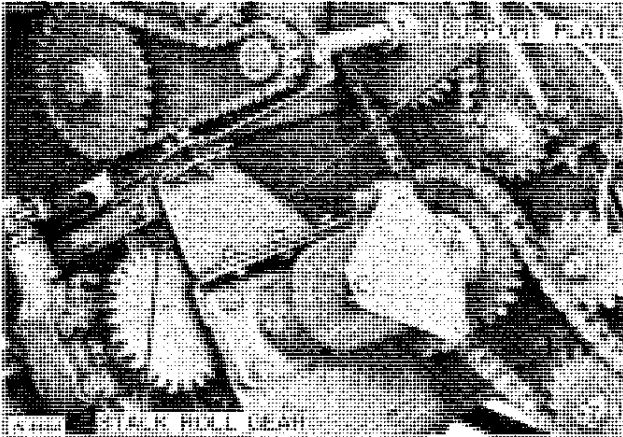

If the stalk rolls are not in time, the flutes may break off stalks. To time the stalk rolls, it is first necessary to disconnect the wheel shield adjusting rod and swing out the shield as far as possible. Then remove the support plate from the gear case attaching bracket. Remove the outer stalk roll gear.

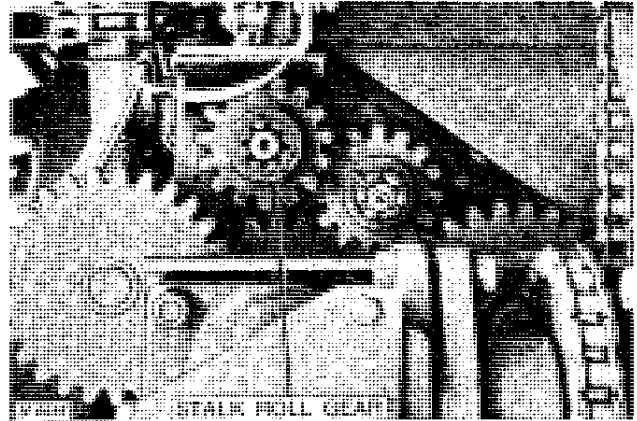

When the rolls are properly timed, replace the outer gear on the stalk roll. Be careful when doing this to make sure you do not disturb the stalk roll setting.

Replace the support plate and shield adjusting rod.

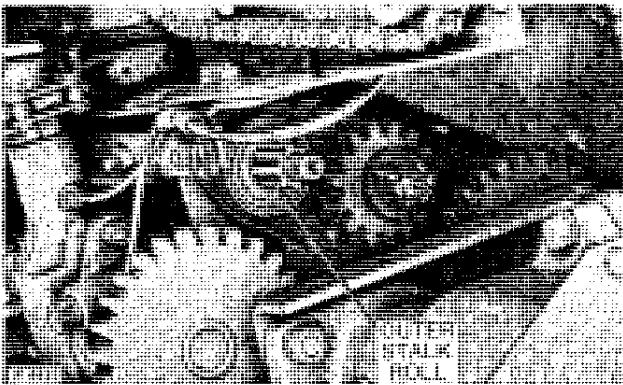

Rotate the outer stalk roll by hand until the cams at the upper end of each pair of rolls are 180 degrees apart. Also make sure the flutes on the outside roll fit exactly in the center between the flutes of the opposite roll. This way the flutes will alternate and there will be no clashing when the rolls are turned.

TRASH KNIVES

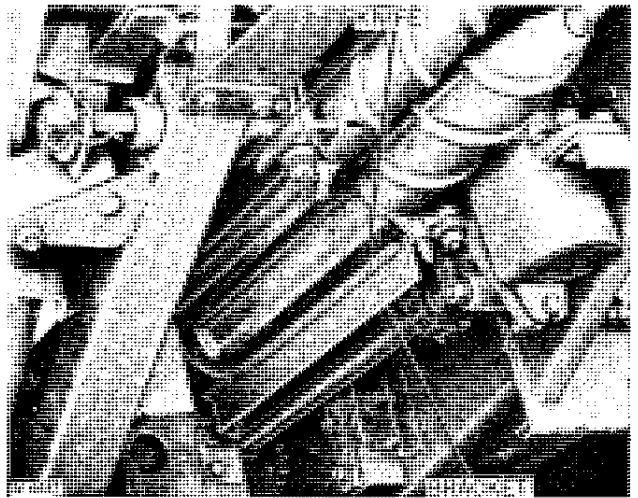

Trash knives prevent weeds and trash from wrapping around the stalk rolls.

The knives should be set as close to the stalk rolls as possible without striking the flutes.

The trash knives can be adjusted closer to or farther from the rolls by using shims between the knife and the bracket.

DECK PLATE AND SNAPPING BAR

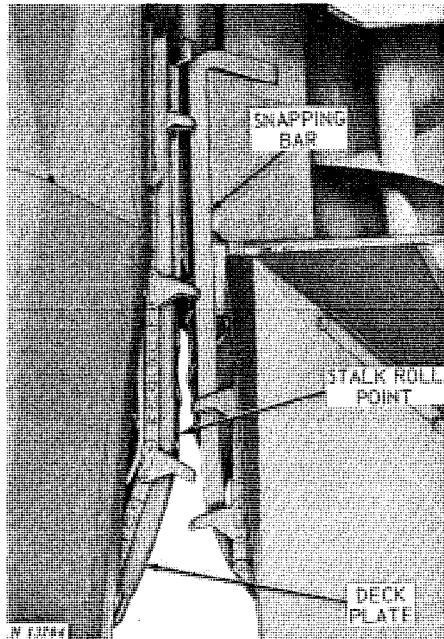

Set the deck plate so the spirals and part of the barrel of the stalk roll point are exposed. If too much of the point is exposed, the spirals will strike the deck plate. If none of the stalk roll is exposed, cornstalks may break against the deck plate and plug the unit.

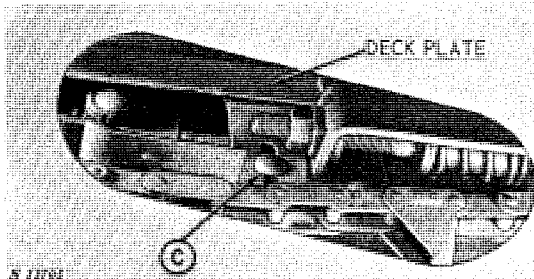

To adjust the deck plate, loosen the nut on bolt "C" and slide deck plate to the desired position. Be sure to tighten the nut.

The snapping bar snaps ears from the cornstalks as the stalks are pulled down by the stalk rolls. The snapping bar spacing is adjustable to meet varying crop conditions.

The snapping bar opening should be just wide enough to snap the small ears. However, if there is excessive stalk breakage, open the bar farther to permit stalk rolls to carry away more material.

Do not set opening wide enough to permit small ears to be carried into the stalk rolls.

A good starting setting is 1-1/4-inch parallel to the deck plate. When stalks are heavy or when picking in extremely weedy or trashy conditions, open the bars farther. In certain adverse field conditions, setting the snapping bar 1/4- to 3/8-inch wider at the rear than at the front will allow more trash and large green stalks to pass between the snapping rolls.

The snapping bar should be set as close to the stalk roll as possible without striking the roll.

IMPORTANT: The snapping bar should always be parallel with the outer gatherer chain deck plate, except when set for heavy trash or large stalks as described above. To prevent plugging at the rear of the snapping bar, always set the rear of the bar 1/2- to 3/4-inch lower than the deck plate.

ADJUSTING SNAPPING BAR

NOTE: Align deck plate with stalk roll before setting snapping bar spacing.

To adjust spacing at the rear of the snapping bar, loosen bolts "A" shown below and slide snapping bar in or out. Set snapping bar 1/2- to 3/4-inch lower than deck plate.

To align the front of the snapping bar with the deck plate, loosen bolt "B" and slide snapping bar in or out.

Tighten all nuts after obtaining proper spacing.

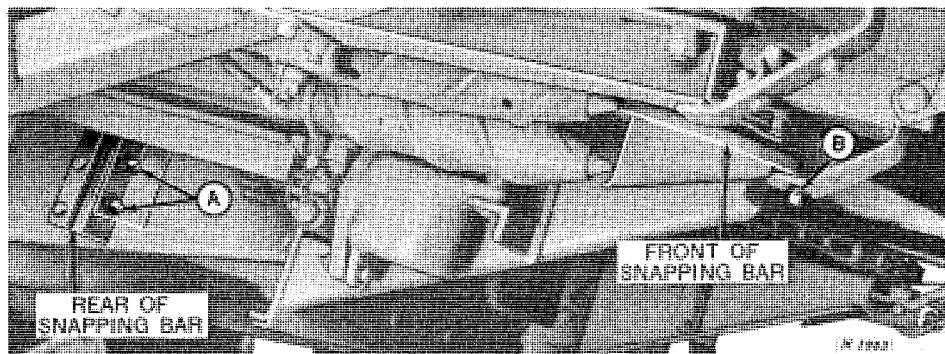



Suggest:

If the above button click is invalid.

Please download this document

first, and then click the above link

to download the complete manual.

Thank you so much for reading

CONVEYOR AUGERS AND TRASH MOVER

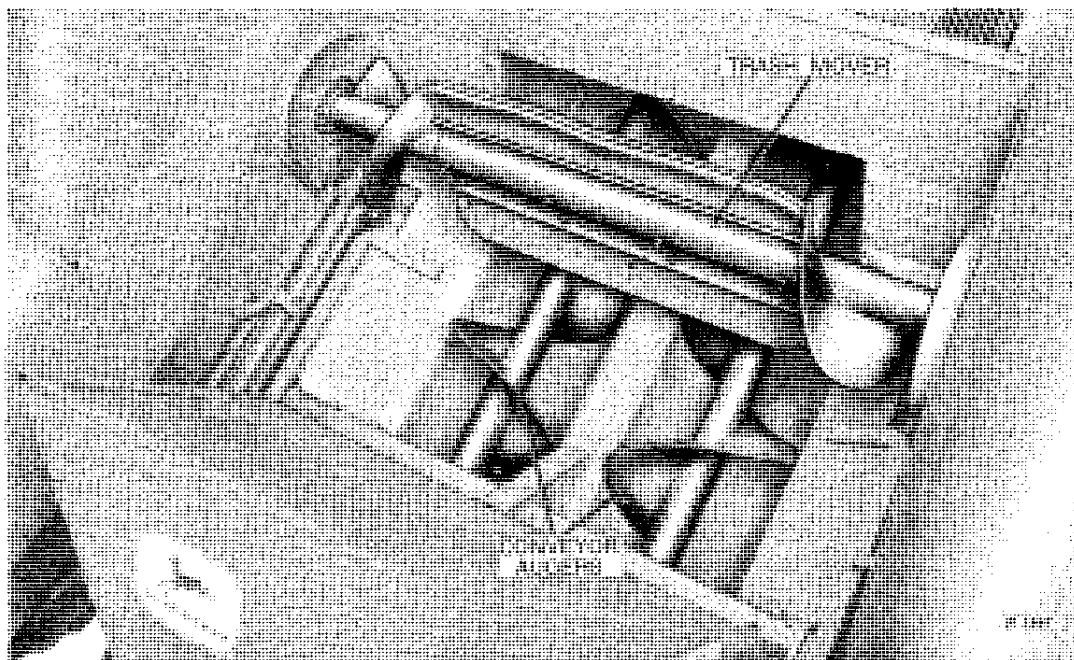

CONVEYOR AUGERS

Two large diameter augers convey the corn from the stalk rolls directly to the combine cylinder. **CAUTION:** In freezing weather, at the end of each day's operation, run the corn attachment slowly for a few minutes to clean the auger housing. In rainy seasons, clean material away from drain holes so water will not collect in the housing.

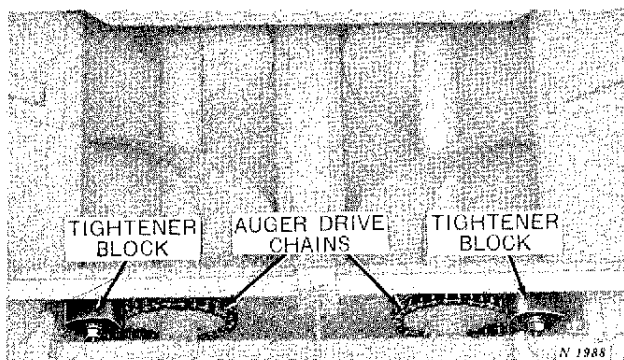

The conveyor auger drive chains are located at the bottom of the augers ahead of the bulkhead.

A wooden block acts as a tightener for each auger drive chain. The tightness of these chains should be checked periodically.

To adjust the chain tightness, loosen the nut on the wooden block and move the block until the proper tightness is obtained.

When one side of the tightener block becomes worn, the block can be turned over and the other side used against the chain.

TRASH MOVER

The trash mover is located directly above the conveyor augers to start trash and broken stalks into the conveyor housing.

The tire carcass type paddles keep material moving into the augers. The augers on either end of the trash mover take material away from the upper ends of the stalk rolls and force it into the conveyor augers.

<https://www.ebooklibonline.com>

Hello dear friend!

Thank you very much for reading.

Enter the link into your browser.

The full manual is available for immediate download.

<https://www.ebooklibonline.com>