

JOHN DEERE
AG & TURF DIVISION

Walk Greens Mower
180SL, 220SL, and 260SL

OMTCU29318 D2

OPERATOR'S MANUAL



JOHN DEERE

Export Version
Printed in U.S.A.

Introduction

Thank You for Purchasing a John Deere Product

We appreciate having you as a customer and wish you many years of safe and satisfied use of your machine.

Using Your Operator's Manual

This manual is an important part of your machine and should remain with the machine when you sell it.

Reading your operator's manual will help you and others avoid personal injury or damage to the machine. Information given in this manual will provide the operator with the safest and most effective use of the machine. Knowing how to operate this machine safely and correctly will allow you to train others who may operate this machine.

If you have an attachment, use the safety and operating information in the attachment operator's manual along with the machine operator's manual to operate the attachment safely and correctly.

This manual and safety signs on your machine may also be available in other languages (see your authorized dealer to order).

Sections in your operator's manual are placed in a specific order to help you understand all the safety messages and learn the controls so you can operate this machine safely. You can also use this manual to answer any specific operating or servicing questions. A convenient index located at the end of this book will help you to find needed information quickly.

The machine shown in this manual may differ slightly from your machine, but will be similar enough to help you understand our instructions.

RIGHT-HAND and LEFT-HAND sides are determined by facing in the direction the machine will travel when going forward. When you see a broken line (-----), the item referred to is hidden from view.

Before delivering this machine, your dealer performed a predelivery inspection to ensure best performance.

Machine Use

This machine is designed solely for use in customary lawn and turf mowing operations. Use in any other way is considered as contrary to the intended use.

The manufacturer accepts no liability for damage or injury resulting from this misuse, and these risks must be borne solely by the user. Compliance with and strict adherence to the conditions of operation, service and repair as specified by the manufacturer also constitute essential elements for

the intended use.

This machine should be operated, serviced and repaired only by persons familiar with all its particular characteristics and acquainted with the relevant safety rules (accident prevention). The accident prevention regulations, all other generally recognized regulations on safety and occupational medicine and the road traffic regulations must be observed at all times.

Setting fuel delivery beyond published factory specifications or otherwise overpowering will result in loss of warranty protection for this machine.

Any arbitrary modifications carried out on this machine will relieve the manufacturer of all liability for any resulting damage or injury.

Special Messages

Your manual contains special messages to bring attention to potential safety concerns, machine damage as well as helpful operating and servicing information. Please read all the information carefully to avoid injury and machine damage.



CAUTION: Avoid injury! This symbol and text highlight potential hazards or death to the operator or bystanders that may occur if the hazards or procedures are ignored.

IMPORTANT: Avoid damage! This text is used to tell the operator of actions or conditions that might result in damage to the machine.

NOTE: General information is given throughout the manual that may help the operator in the operation or service of the machine.

Product Identification

Record Identification Numbers

Walk Greens Mower

180SL, 220SL, and 260SL PIN (010001-)

If you need to contact an Authorized Service Center for information on servicing, always provide the product model and serial number.

You will need to locate the model and serial number for the machine and for the engine of your machine and record the information in the spaces provided below.

DATE OF PURCHASE:

DEALER NAME:

DEALER PHONE:

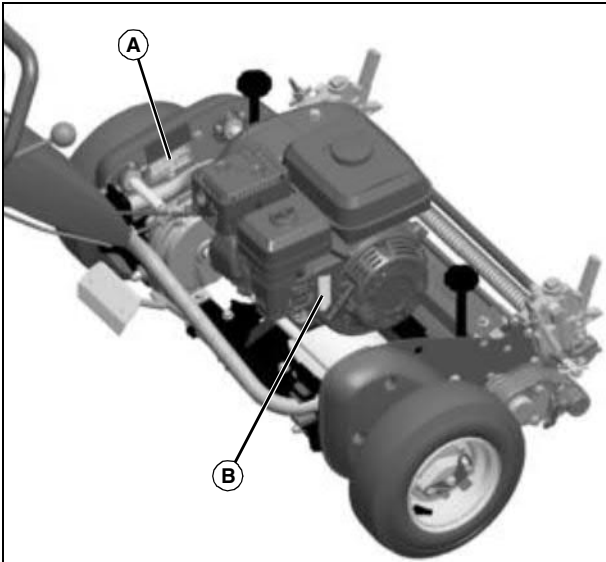

MX46471

PRODUCT IDENTIFICATION NUMBER (A):

ENGINE SERIAL NUMBER (B):

<https://www.ebooklibonline.com>

Hello dear friend!

Thank you very much for reading.

Enter the link into your browser.

The full manual is available for immediate download.

<https://www.ebooklibonline.com>

Table of Contents

Safety Labels	1
Safety	4
Operating Controls	8
Operating	9
Operating - Cutting Units	14
Replacement Parts	22
Service Intervals	23
Service Lubrication	24
Service Engine	29
Service - Belts	35
Service - Cutting Units	40
Troubleshooting	43
Storage	45
Assembly	47
Specifications	56
Declaration of Conformity	59
Declaration of Conformity	60
Declaration of Conformity	61
Index	62

Original Instruction

All information, illustrations and specifications in this manual are based on the latest information at the time of publication. The right is reserved to make changes at any time without notice.

COPYRIGHT© 2012

Deere & Co.

John Deere Ag & Turf Division

All rights reserved

Previous Editions

COPYRIGHT© 2010

OMTCU29318 D2 -

Safety Labels

Safety Label Location

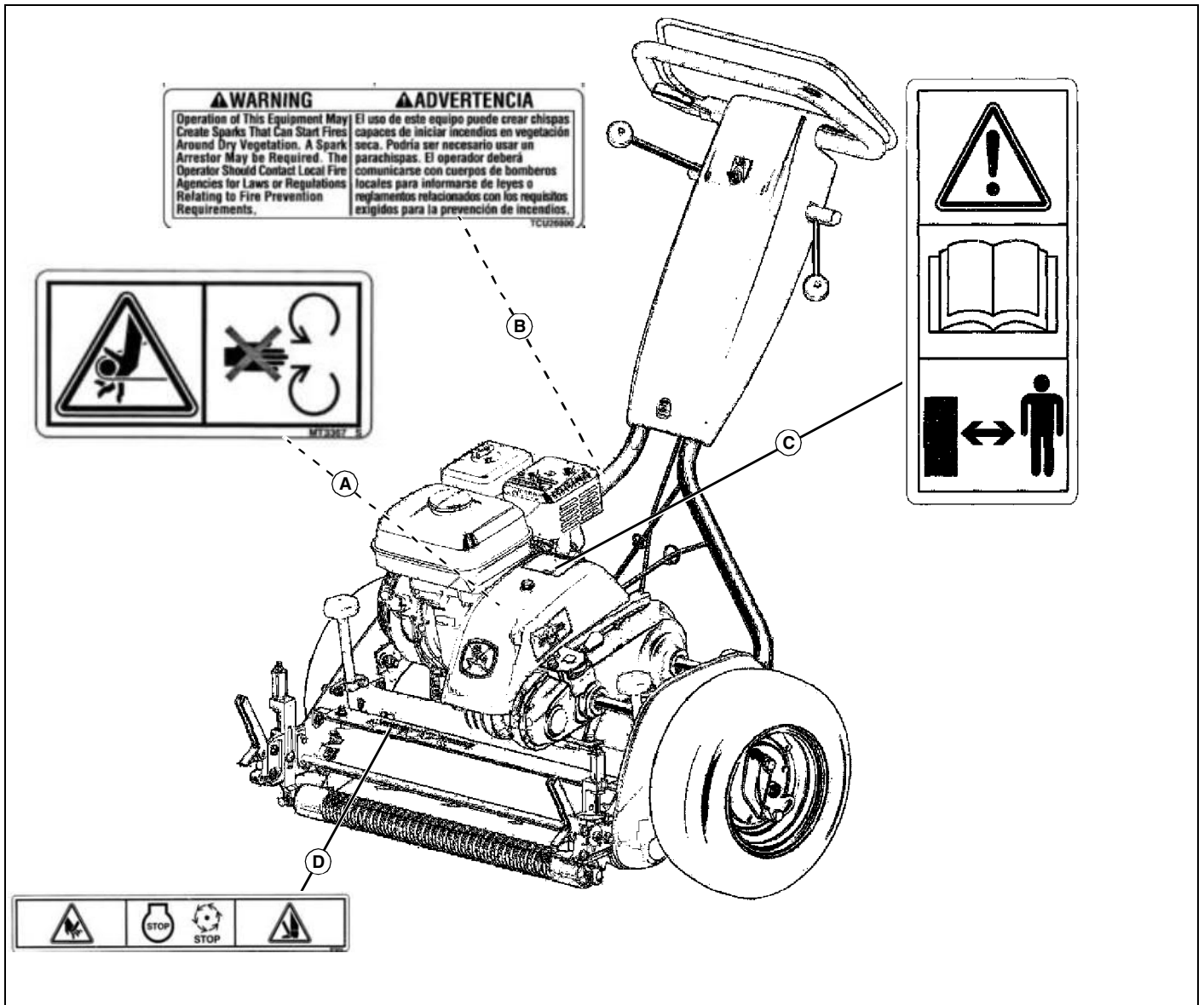

MX43492

- A - WARNING MT3367**
- B - WARNING TCU26800**
- C - CAUTION MT7234**
- D - DANGER MT6732**

There can be additional safety information contained on parts and components sourced from suppliers that is not reproduced in this operator's manual.



Pictorial Safety Signs

At several important places on this machine safety signs are affixed intended to signify potential danger. The hazard is identified by a pictorial in a warning triangle. An adjacent pictorial provides information how to avoid personal injury. These safety signs, their placement on the machine and a brief explanatory text are shown in this Safety section.

Safety Labels

Warning

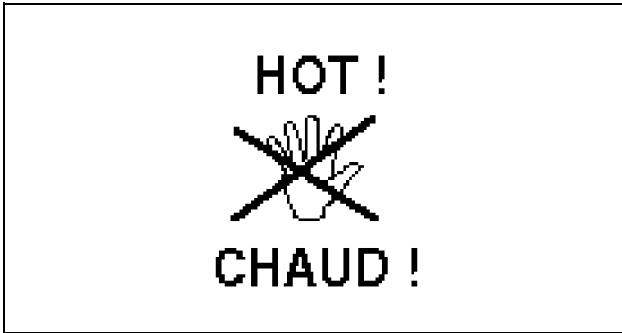

- Hot surface

Warning MT3367

Keep All Shields In Place

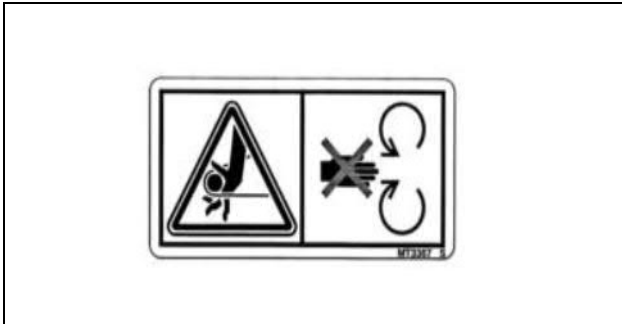

MT3367

- Do not operate machine without shield in place.

WARNING TCU26800

SPARK ARRESTOR



TCU26800

Operation of This Equipment May Create Sparks That Can Start Fires Around Dry Vegetation. A Spark Arrestor May Be Required. The Operator Should Contact Local Fire Agencies for Laws or Regulations Relating to Fire Prevention Requirements.

Warning MT7234

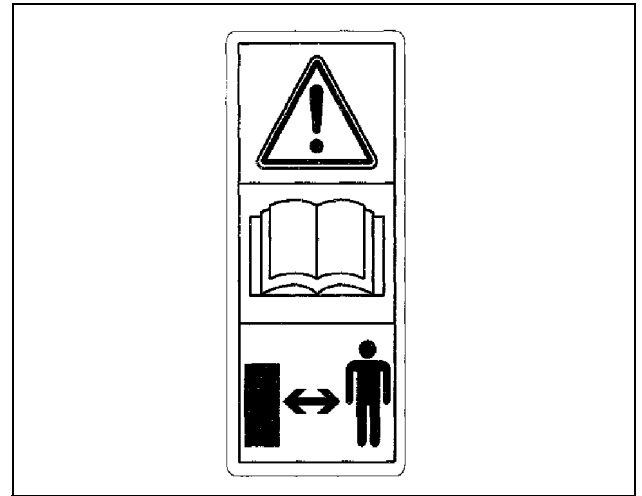

MT7234

Help Avoid Injury

- Read operator's manual for operating and training instructions.
- Keep shields in place.
- Keep people a safe distance away.
- Maintain all safety devices.
- Stop engine whenever you leave the mower.

Danger - MT6732

Avoid Injury From Rotating Blades

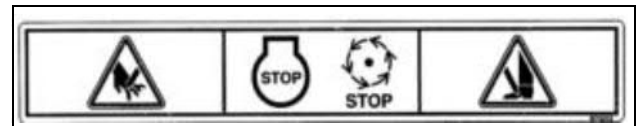

MT6732

- Keep hands and feet away from rotating blades.
- Shut off engine before servicing, lubricating or removing cutting units.

Safety Labels

CE Certification Label

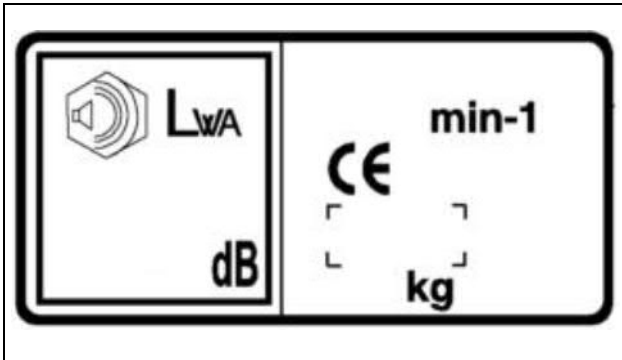

MT7210

This information is provided on your machine to indicate the machine is certified and in compliance with European Directive Standards: 98/37/EC (before December 29, 2009) or 2006/42/EC.

Safety

Training

- Read the instructions carefully. Be familiar with the controls and the proper use of the equipment.
- Never allow children or people unfamiliar with these instructions to use the lawnmower. Local regulations can restrict the age of the operator.
- Never mow while people, especially children, or pets are nearby.
- Keep in mind that the operator or user is responsible for accidents or hazards occurring to other people or their property.

Preparation

- While mowing, always wear substantial footwear and long trousers. Do not operate the equipment when barefoot or wearing open sandals.
- Thoroughly inspect the area where the equipment is to be used and remove all objects which can be thrown by the machine.
- **WARNING-Fuel is highly flammable.**
 - store fuel in containers specifically designed for this purpose.
 - refuel outdoors only and do not smoke while refueling.
 - add fuel before starting the engine. Never remove the cap of the fuel tank or add fuel while the engine is running or when the engine is hot.
 - if fuel is spilled, do not attempt to start the engine but move the machine away from the area of spillage and avoid creating any source of ignition until fuel vapors have dissipated.
 - replace all fuel tank and container caps securely.
- Replace faulty silencers.

Operation

- Do not operate the engine in a confined space where dangerous carbon monoxide fumes can collect.
- Mow only in daylight or in good artificial light.
- Avoid operating the equipment in wet grass, where feasible.
- Always be sure of your footing on slopes.
- Walk, never run.
- For wheeled rotary machines, mow across the face of slopes, never up and down.

- Exercise extreme caution when changing direction on slopes.
- Do not mow on excessively steep slopes.
- Use extreme caution when reversing or pulling the machine towards you.
- Stop the blades if the lawnmower has to be tilted for transportation when crossing surfaces other than grass, and when transporting the lawnmower to and from the area to be mowed.
- Never operate the machine with defective guards, or without safety devices, for example deflectors and/or grasscatchers, in place.
- Disengage all blade and drive clutches before starting the engine.
- Start the engine or switch on the motor carefully according to instructions and with feet well away from the blade.
- Never pick up or carry a lawnmower while the engine is running.
- Reduce the throttle setting during engine shutdown and, if the engine is provided with a shut-off valve, turn the fuel off at the conclusion of mowing.
- Do not change the engine governor settings or overspeed the engine. Operating an engine at excessive speed can increase the hazard of personal injury.
- Do not put hands or feet near rotating parts while the mower is being operated.
- Stop the engine and disconnect the spark plug wire, make sure that all moving parts have come to a complete stop and, where a key is fitted, remove the key:
 - before checking, cleaning, or working on the mower;
 - after striking a foreign object. Inspect the mower for damage and make repairs before restarting and operating the mower;
 - if the mower starts to vibrate abnormally (check immediately).
- Stop the engine and disconnect the spark plug wire, make sure that all moving parts have come to a complete stop and, where a key is fitted, remove the key:
 - whenever you leave the mower;
 - before refueling;
 - before clearing blockages.
- Read, understand and follow all instructions in the manual and on the machine before starting.
- Inspect machine before you operate. Repair or replace damaged, badly worn, or missing parts. Make any necessary adjustments before you operate.

Safety

- Do not operate mower without discharge chute or entire grass catcher in place. Never operate with the discharge deflector raised, removed, or altered, unless using a grass catcher.
- Stop machine if anyone enters the area.
- Use care when approaching blind corners, shrubs, trees, or other objects that may obscure vision.
- Use only accessories and attachments approved by the manufacturer of the machine.
- Do not operate machine if you are under the influence of drugs or alcohol.
- Do not wear radio or music headphones. Safe service and operation requires your full attention.

Parking Safely

1. Stop machine on a level surface, not on a slope.
2. Disengage mower blades.
3. Lock the park brake.
4. Stop the engine.
5. Remove the key.
6. Wait for engine and all moving parts to stop before you leave the operator's station.
7. Close fuel shut-off valve, if your machine is equipped.
8. Remove the spark plug wire (for gasoline engines) before servicing the machine.

Maintenance and Storage

- Keep all nuts, bolts and screws tight to be sure the equipment is in safe working condition.
- Never store the equipment with fuel in the tank inside a building where fumes can reach an open flame or spark.
- Allow the engine to cool before storing in any enclosure.
- To reduce the fire hazard, keep the engine, silencer, battery compartment and fuel storage area free of grass, leaves, or excessive grease.
- Check the grasscatcher frequently for wear and deterioration.
- Replace worn or damaged parts for safety.
- If the fuel tank has to be drained, this should be done outdoors.
- Be careful during adjustment of the machine to prevent entrapment of the fingers between moving blades and fixed parts of the machine.

- Never allow untrained personnel to service machine. Understand service procedure before doing work.
- Disengage drives, lower implement, lock parking brake, stop engine and remove key or disconnect spark plug (for gas engines). Wait for all movement to stop before adjusting, cleaning or repairing.
- Let engine cool before storing and do not store near flame.
- Shut off fuel while storing or transporting. Do not store fuel near flames or drain indoors.
- Use care when checking blades. Wrap the blades or wear gloves, and use caution when servicing them. Only replace blades. Never straighten or weld them.
- Keep hands, feet, clothing, jewelry and long hair away from moving parts. If possible, do not make adjustments with the engine running.
- Keep all parts in good working condition and all hardware tightened. Replace all worn or damaged decals.

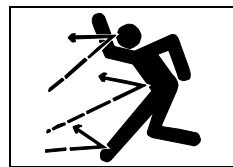

Checking Mowing Area

- Clear mowing area of objects that might be thrown. Keep people and pets out of mowing area.
- Low-hanging branches and similar obstacles can injure the operator or interfere with mowing operation. Before mowing, identify potential obstacles such as low-hanging branches, and trim or remove those obstacles.
- Study mowing area. Set up a safe mowing pattern. Do not mow where traction or stability is doubtful.



Avoid Injury From Contacting Blades

- Rotating cutting cylinders can cut off arms and legs, and throw objects. Failure to observe safety instructions could result in serious injury or death.
- Keep hands, feet and clothing away from rotating cutting cylinders when engine is running.
- Be alert at all times, operate machine carefully. People, especially children can move quickly into the mowing area before you know it.
- Shut off cutting cylinders when you are not mowing.
- Park machine safely before leaving the operator's station for any reason including emptying the grasscatchers.
- Always wear gloves when manually rotating reel.

Safety

- Use a long-handled brush when applying reel-sharpening compound.

- Check fuel lines, tank, cap, and fittings frequently for cracks or leaks. Replace if necessary.

Rotating Blades are Dangerous - Protect Children and Prevent Accidents

Protect Children:

- Tragic accidents can occur if the operator is not alert to the presence of children. Children are often attracted to lawn-mowing machines and mowing activity. Stay alert to the presence of children. Never assume that children will remain where you last saw them.
- Keep children indoors, out of the mowing area, and in the watchful eye of a responsible adult, other than the operator, when a mower is being operated.
- Be alert and turn mower off if a child enters the work area. They don't understand the dangers of rotating blades or the fact that the operator is unaware of their presence.

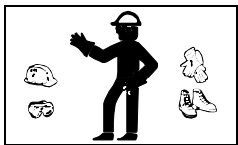

Wear Appropriate Clothing

- Always wear safety goggles, or safety glasses with side shields when operating the machine.
- Wear close fitting clothing and safety equipment appropriate for the job.
- While mowing, always wear substantial footwear and long trousers. Do not operate the equipment when barefoot or wearing open sandals.
- Wear a suitable protective device such as earplugs. Loud noise can cause impairment or loss of hearing.

Prevent Fires

- Machine fires and structure fires can occur if a machine is stored before allowing it to cool, if debris is not removed from critical areas of the machine, or if machine is stored near combustible materials.
- Remove grass and debris completely from engine compartment and muffler area, and from on top of the mower deck, before and after operating machine, especially after mowing or mulching in dry conditions.
- Empty any grasscatcher bags or containers completely before storing.
- Always shut off fuel when storing or transporting machine, if the machine has a fuel shutoff.
- Do not store machine near an open flame or source of ignition, such as a water heater or furnace.

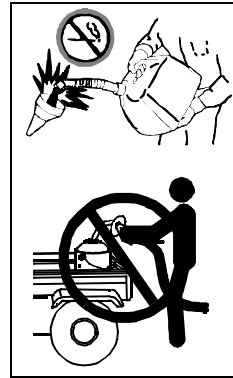

Handling Fuel Safely

To avoid personal injury or property damage, use extreme care in handling fuel. Fuel is extremely flammable and fuel vapors are explosive:

- Extinguish all cigarettes, cigars, pipes, and other sources of ignition.
- Use only approved non-metal, portable fuel containers. If using a funnel, make sure it is plastic and has no screen or filter.
- Never remove the fuel tank cap or add fuel with the engine running. Allow engine to cool before refueling.
- Never add fuel to or drain fuel from the machine indoors. Move machine outdoors and provide adequate ventilation.
- Clean up spilled fuel immediately. If fuel is spilled on clothing, change clothing immediately. If fuel is spilled near machine, do not attempt to start the engine but move the machine away from the area of spillage. Avoid creating any source of ignition until fuel vapors have dissipated.
- Never store the machine or fuel container where there is an open flame, spark, or pilot light such as on a water heater or other appliance.
- Prevent fire and explosion caused by static electric discharge. Static electric discharge can ignite fuel vapors in an ungrounded fuel container.
- Never fill containers inside a vehicle or on a truck or trailer bed with a plastic liner. Always place containers on the ground away from your vehicle before fueling.
- Remove fuel-powered equipment from the truck or trailer and refuel it on the ground. If this is not possible, then refuel such equipment with a portable container, rather than from a fuel dispenser nozzle.
- Keep the nozzle in contact with the rim of the fuel tank or container opening at all times until the fueling is complete. Do not use a nozzle lock-open device.
- Never overfill fuel tank. Replace fuel tank cap and tighten securely.
- Replace all fuel container caps securely after use.
- For gasoline engines, do not use gas with methanol. Methanol is harmful to your health and to the environment.

Safety

Handling Waste Product and Chemicals

Waste products, such as, used oil, fuel, coolant, brake fluid, and batteries, can harm the environment and people:

- Do not use beverage containers for waste fluids - someone may drink from them.
- See your local Recycling Center or authorized dealer to learn how to recycle or get rid of waste products.
- See your local Recycling Center or authorized dealer to learn how to put your machine out of service at the end of the machine's service life.

Operating Controls

Operating Controls

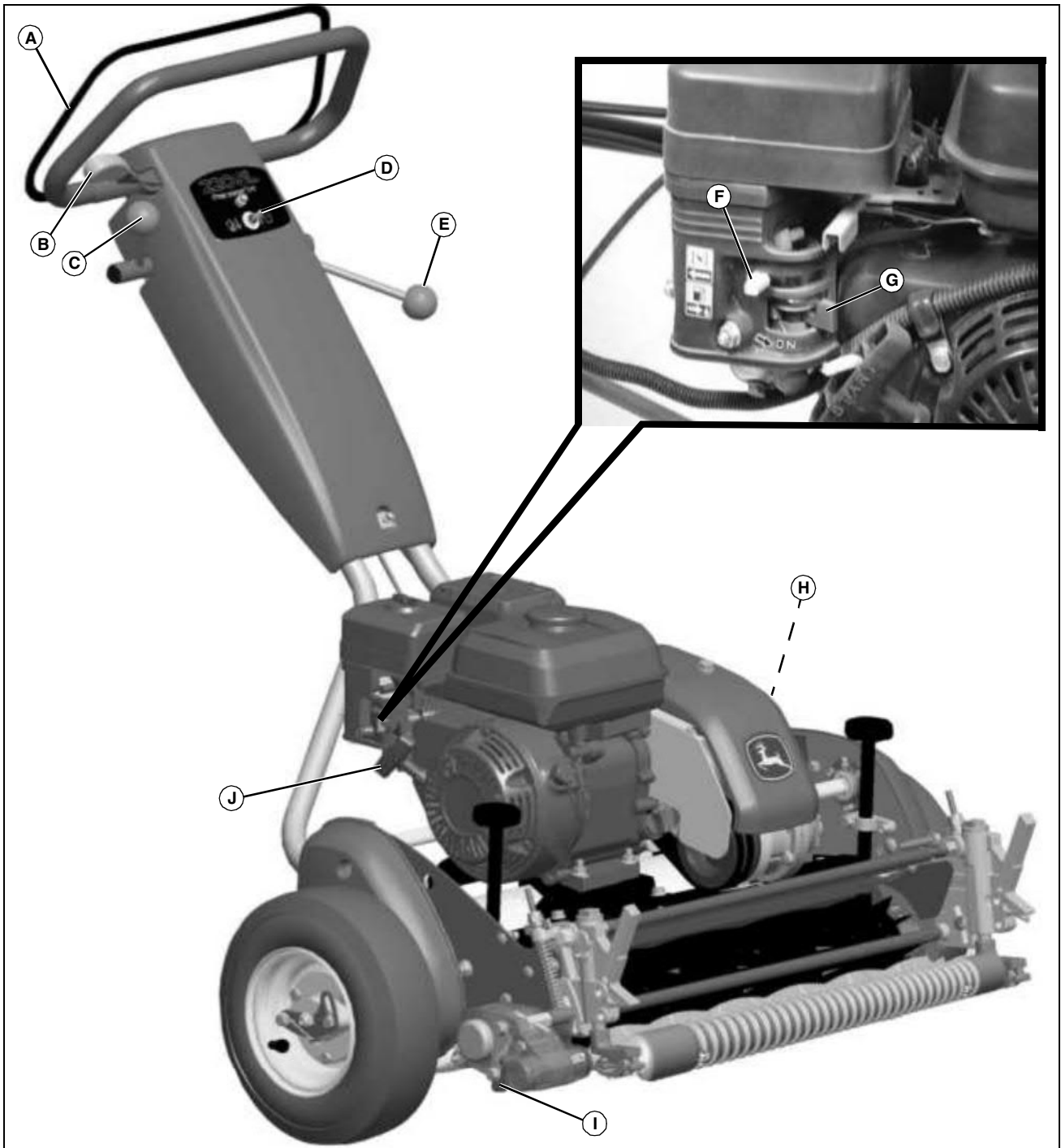

MX46472, M86618

Key	Description	Key	Description
A	Operator Presence Bail	F	Choke Lever
B	Throttle Lever	G	Fuel Shut-Off Valve
C	Travel Clutch Lever	H	Reel Clutch Handle
D	Run/Off Switch	I	GTC or Rotary Brush Handle
E	Park Brake Lever	J	Starter Handle

Operating

Daily Operating Checklist

- Test safety systems.
- Check tire pressure.
- Check fuel level.
- Check engine oil level.
- Remove grass and debris from engine compartment and muffler area, and on top of cutting unit, before and after operating machine.
- Clean air intake screen.
- Check area below machine for leaks.

Avoid Damage to Plastic and Painted Surfaces

- Do not wipe plastic parts unless rinsed first. Using a dry cloth may cause scratches.
- Insect repellent spray may damage plastic and painted surfaces. Do not spray insect repellent near machine.
- Be careful not to spill fuel on machine. Fuel may damage surface. Wipe up spilled fuel immediately.
- Prolonged exposure to sunlight will damage hood surfaces.

Adjusting Handlebar

NOTE: Make sure bracket (B) is straight up and down, and not at an angle.

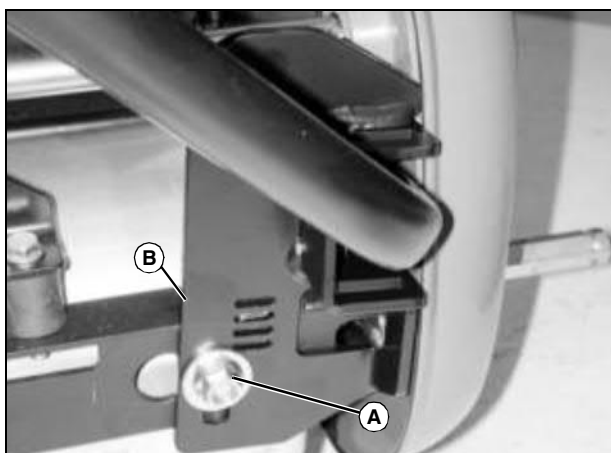

MX12973

1. Loosen nut (A) on each side of machine.
2. Position handlebar to desired position and tighten nut (A).

Using Operator Controls

Using Run Switch

Push run/off toggle switch forward to run engine.

- Pull run/off toggle switch back (toward operator) to stop engine.

Using Operator Presence Bail

The operator presence bail stops all moving parts when released.

The operator presence bail when squeezed with handlebar permits engagement of the clutch lever.

Using Travel Clutch Lever (Forward Travel)

1. Hold operator presence bail to handlebar.
2. Push travel clutch lever forward to engage drive clutch.
3. Release bail to stop travel.

Using Park Brake Lever

Release operator presence bail and pull brake lever back to stop mower movement.

Using Throttle Lever

Use throttle lever to adjust engine speed and rate of travel.

Pull lever back (toward operator) to reduce engine speed.

Adjust throttle lever depending on rate of travel, cutting height, and ground contour.

Using Choke Lever

Move choke lever left toward the decal for the choke position.

Using Fuel Shut-Off Valve

This unit is equipped with a 2-position fuel shut-off valve. Slide lever to the right to open or to the left to close the fuel shut-off valve.

Closed (off) position:

- When performing any type of engine service.
- When transporting.
- During storage.

Open (on) position:

- Fuel shut-off valve must be in the full open (on) position for proper fuel delivery to the engine.

Using Greens Tender Conditioner (GTC) Handle

Turn handle up in the (detent) position for run.

Turn handle down in the (detent) position for off.

Operating

Using Reel Clutch Handle

1. Park the machine safely. (See Parking Safely in the Safety section.)

CAUTION: Avoid injury! Clutch handle may be difficult to turn. Do not grab reel with hand to loosen clutch handle as blades are sharp.

NOTE: Do not force or kick the clutch handle, the machine may need to be rocked to move handle.

Clutch handle must be in a stop position when transporting. Only move clutch handle into mow position when preparing to mow. Never engage reel clutch when mower is moving.

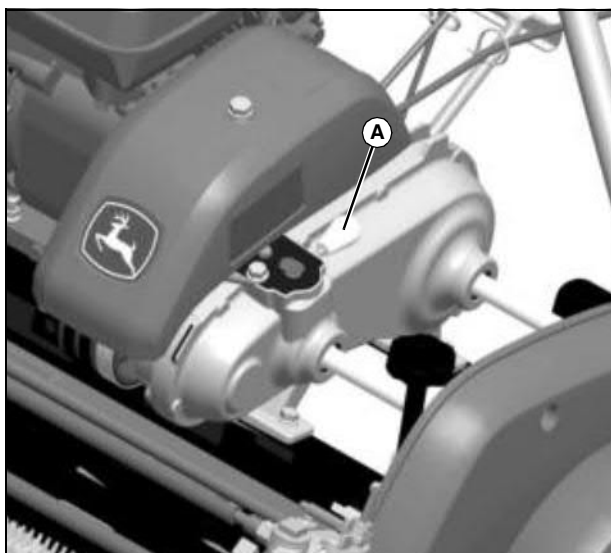

MX46473

- Clutch handle (A) points toward the rear when at stop and full forward when at the mow position.
- Handle will turn 180 degrees from stop to mow.

NOTE: Reel will turn only when travel clutch lever is engaged and reel clutch handle is in the mow position.

Removing Transport Wheels

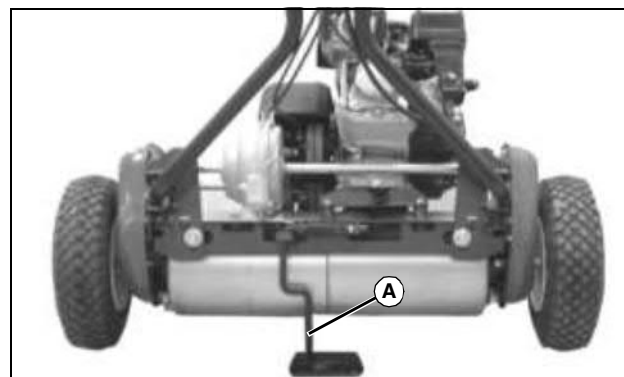

MX6037

1. Place machine on stand (A).

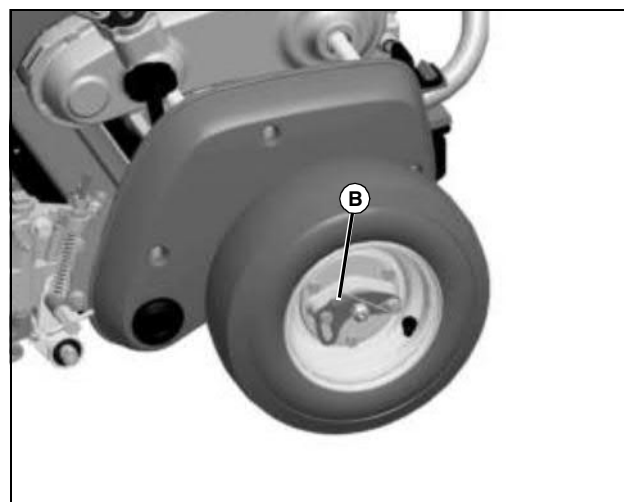

MX46474

2. Release latch (B) and slide wheel from shaft. Repeat procedure for other side.

Operating

Starting the Engine



CAUTION: Avoid injury! Engine exhaust fumes contain carbon monoxide and can cause serious illness or death.

- Move the machine to an outside area before running the engine.
- Do not run an engine in an enclosed area without adequate ventilation.
- Connect a pipe extension to the engine exhaust pipe to direct the exhaust fumes out of the area.
- Allow fresh outside air into the work area to clear the exhaust fumes out.

1. Lock park brake lever.
2. Push PTO switch to OFF position.
3. Disengage travel clutch lever.
4. Push run/off switch forward to on the position.
5. Move throttle lever to half open position.

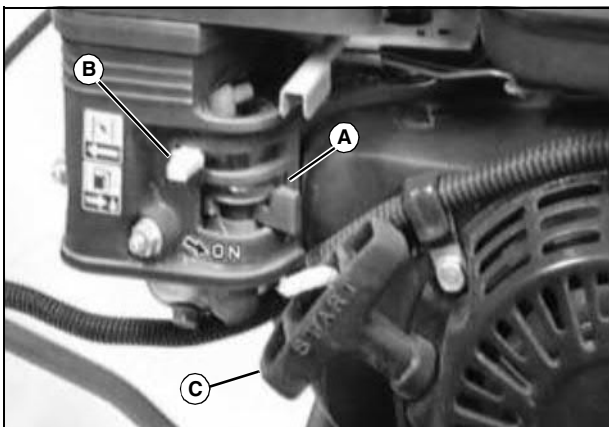

M86618

6. Turn fuel shut-off valve (A) to the on position.
 7. Set choke (B) at closed position.
 8. Pull starter handle (C).
- NOTE:** If engine fails to start after three attempts, return choke to open.
9. Move choke to the open position after engine has started.
 10. Allow engine to warm up before applying load.

Stopping the Engine

1. Release operator presence bail.

2. Pull throttle lever all the way back (toward operator). Let engine idle 2-4 minutes to allow engine to cool down.

NOTE: If mower will not be used for a long period, close fuel shut-off valve (A) and leave run/off switch in the run position.

Engine will continue to run for a few minutes.

After engine stops completely, pull run/off switch back (toward operator) to stop the position.

3. Pull run/off switch back (toward operator) to stop engine.



MX11246

4. Turn fuel shut-off valve (A) to the off position.

Testing Safety Systems

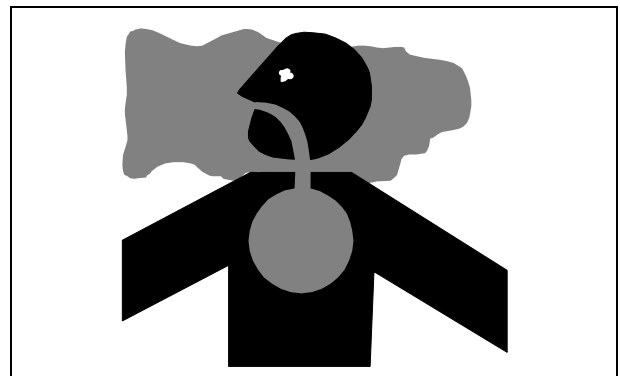

Operating



CAUTION: Avoid injury! Engine exhaust fumes contain carbon monoxide and can cause serious illness or death.

- Move the machine to an outside area before running the engine.
- Do not run an engine in an enclosed area without adequate ventilation.
- Connect a pipe extension to the engine exhaust pipe to direct the exhaust fumes out of the area.
- Allow fresh outside air into the work area to clear the exhaust fumes out.

The safety systems installed on your machine should be checked before each machine use. Be sure you have read the machine operator manual and are completely familiar with the operation of the machine before performing these safety system checks.

Use the following checkout procedures to check for normal operation of machine.

If there is a malfunction during one of these procedures, do not operate machine. **See your authorized dealer for service.**

Perform these tests in a clear open area. Keep bystanders away.

Testing Park Brake

1. Lock park brake.
2. Run engine at low idle.
3. Engage operator presence bail.
4. Slowly engage travel clutch lever.

Result: Engine should stall with no movement of the mower.

Testing Run Switch

1. Flip run switch rearward (toward operator) to OFF position.
2. Pull start handle.

Result: Engine should not start.

Testing Operator Presence Bail

1. Operate machine in clear open area.

2. Release operator presence bail.

Result: Cutting reel should stop rotating and machine should stop moving forward. Engine should continue to run.

Transporting Machine on Trailer

Be sure trailer has all the necessary lights and signs required by law.



CAUTION: Avoid injury! Use extra care when loading or unloading the machine into a trailer or truck.

Close fuel shut-off valve, if your machine is equipped.

NOTE: Trailer capacity must exceed combined machine weight and attachment weight. (See Specifications section in operator's manual.)

1. Park trailer on a level surface.
2. Move forward onto heavy-duty trailer.
3. Lock park brake.
4. Turn off machine.
5. Machines with fuel shut-off: Turn fuel shut-off to off position.

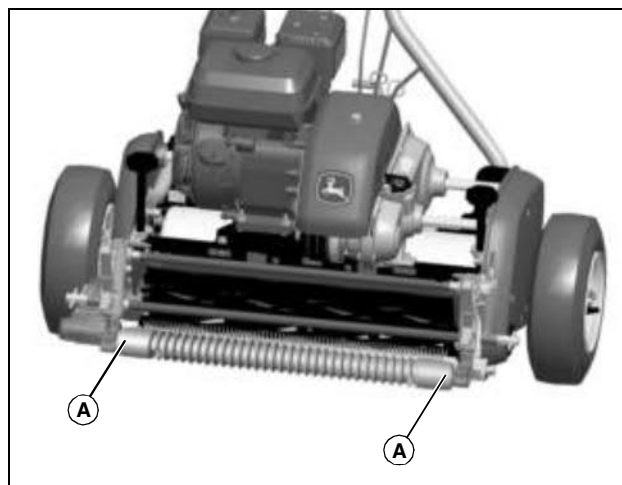

MX46475

6. Fasten front of machine at both sides of the front roller at points (A) to trailer with heavy-duty straps, chains, or cables. Straps must be directed down and outward from machine.

Operating

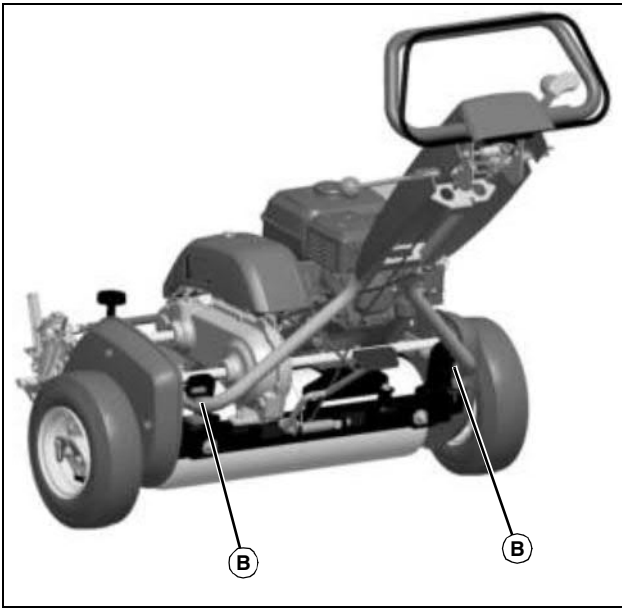

MX46476

7. Fasten rear of machine at both sides of the handlebars at points (B) to trailer with heavy-duty straps, chains, or cables. Straps must be directed down and outward from machine.

Emergency Stopping



CAUTION: Avoid injury! The machine may be unstable if stopped suddenly. Do not stop suddenly unless it is an emergency.

1. Release operator presence bail.
2. Engage parking brake lever.
3. Turn run/off switch to off position.



Suggest:

If the above button click is invalid.

Please download this document first, and then click the above link to download the complete manual.

Thank you so much for reading

Operating - Cutting Units

Cleaning Cutting Unit

IMPORTANT: Avoid damage! Grease after washing to purge fittings and bearings of water.

Do not use high-pressure water to clean grass from cutting units.

- Use high volume, low-pressure water to clean exterior of machine.
- Do not use water to wash where electrical components are located. If water penetrates electrical connections it may create problems.
- Use compressed air not water to clean air screens. Reduce compressed air to less than 210 kPa (30 psi) when using for cleaning purposes. Clean grease fittings before lubricating. Replace lost or broken fittings immediately.

Adjusting Bed Knife-To-Reel



CAUTION: Avoid injury! Blades are sharp. Always wear gloves when handling blades or working near blades.

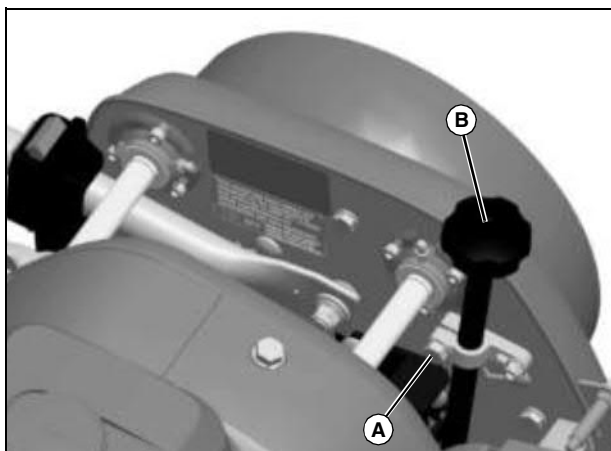

MX46477

1. To adjust clearance between knife and reel blades, loosen clamp bolt (A).

NOTE: Reel must turn freely by hand.

2. Turn adjusting knob (B) clockwise to decrease clearance. Turn adjusting knob counterclockwise to increase clearance.

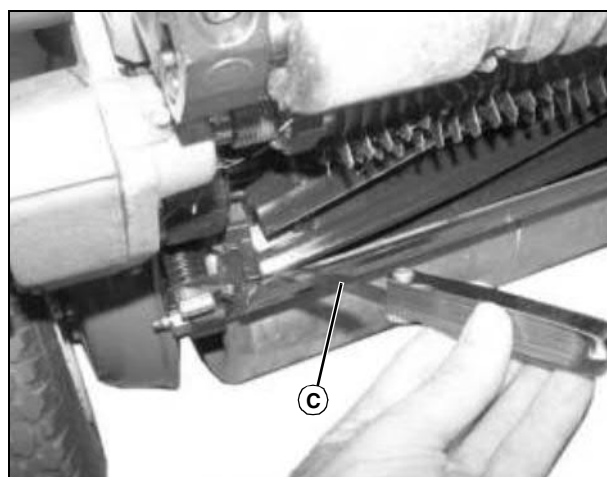

MX49496

3. Adjust ends of reel to 0.001" with feeler gauge (C).
4. Now inspect the entire length of the bed knife with a 0.002" feeler gauge. It should not go in anywhere if it does, go to step 7.
5. If the reel is contacting anywhere, go to Step 6.

NOTE: Always rotate the reel in the reverse direction to avoid damaging or dulling the cutting edges of the reel or bed knife.

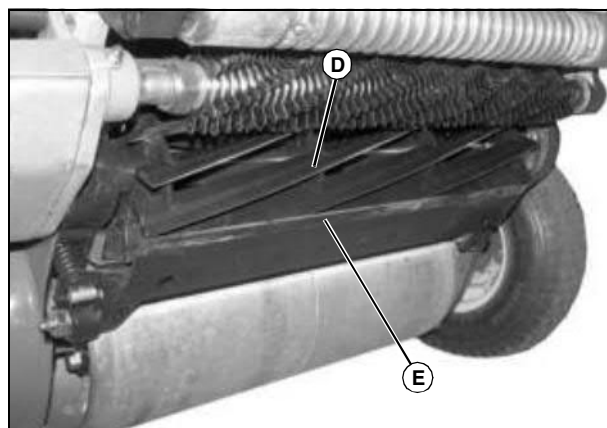

MX46578

6. Slowly rotate the reel (D) backwards watching for contact between the reel and bed knife (E) at the center of the bed knife. If contact is made, backlap the reel and bed knife to eliminate the "Frown" in the bed knife or the out-of-round condition of the reel.
7. Measure the clearance at the center of the bed knife. If the clearance exceeds 0.002 of an inch, backlap the reel and bed knife to eliminate the "Smile" in the bed knife or the out-of-round condition of the reel.

<https://www.ebooklibonline.com>

Hello dear friend!

Thank you very much for reading.

Enter the link into your browser.

The full manual is available for immediate download.

<https://www.ebooklibonline.com>