

# JOHN DEERE 95H COMBINES



## OPERATORS MANUAL JOHN DEERE 95H COMBINES

OMH60253 C5 English

**OMH60253 C5**

LITHO IN THE U.S.A.  
ENGLISH



## TO THE PURCHASER

The combine you have purchased has been carefully designed and manufactured to provide years of dependable, economical service.

To further insure trouble-free service we recommend that you follow closely all instructions concerning operation, lubrication, adjustments and service. Preventive maintenance has proved to be much more economical than corrective maintenance. Should you require information not covered in this manual, consult your John Deere dealer.

### KEEP YOUR COMBINE A JOHN DEERE COMBINE.

Genuine John Deere Parts fit properly and insure satisfactory service because they are made from the original patterns and from the same materials as used in new machines. If your combine requires replacement parts, go to your John Deere dealer where you can obtain Genuine John Deere Parts—accept no substitutes.

### ATTACHMENTS

In addition to the equipment furnished with your combine, there are attachments available to help you do a better job of combining in a special crop or condition. These attachments, illustrated and described in the Attachment section, are available from your John Deere dealer.

### LOCATION REFERENCE

"Right-hand" and "left-hand" sides are determined by facing in the direction the combine will travel when in use.

Radiator end of the engine is referred to as the "front," flywheel end as the "rear."

### SERIAL NUMBERS

Your combine, cutting platform, axle, and engine have serial numbers.

When ordering parts, always bring with you the model and serial numbers as given on the serial number plates. By doing so, you will assist your John Deere dealer in giving you

prompt, efficient service. For your convenience a space is provided below for recording these numbers.

The combine serial number is on a plate located on the support bracket at the rear end of the fuel tank.

The engine serial number is on a plate located between the distributor and generator.

The axle serial number is on the top, left-hand end of the axle tube.

The cutting platform serial number is located on the right-hand side sheet.

Combine Serial No. \_\_\_\_\_

Engine Serial No. \_\_\_\_\_

Axle Serial No. \_\_\_\_\_

Cutting Platform Serial No. \_\_\_\_\_

Date Purchased \_\_\_\_\_

## CONTENTS

	Page
Specifications . . . . .	2
Controls and instruments . . . . .	5
Operation . . . . .	8
Safety suggestions . . . . .	16
Lubrication and periodic service . . . . .	17
Adjustments and service . . . . .	32
Trouble shooting . . . . .	70
Engine service . . . . .	77
Attachments . . . . .	90
Index . . . . .	93

Operator's Manual Price



**<https://www.ebooklibonline.com>**

Hello dear friend!

Thank you very much for reading.

Enter the link into your browser.

The full manual is available for immediate download.

**<https://www.ebooklibonline.com>**

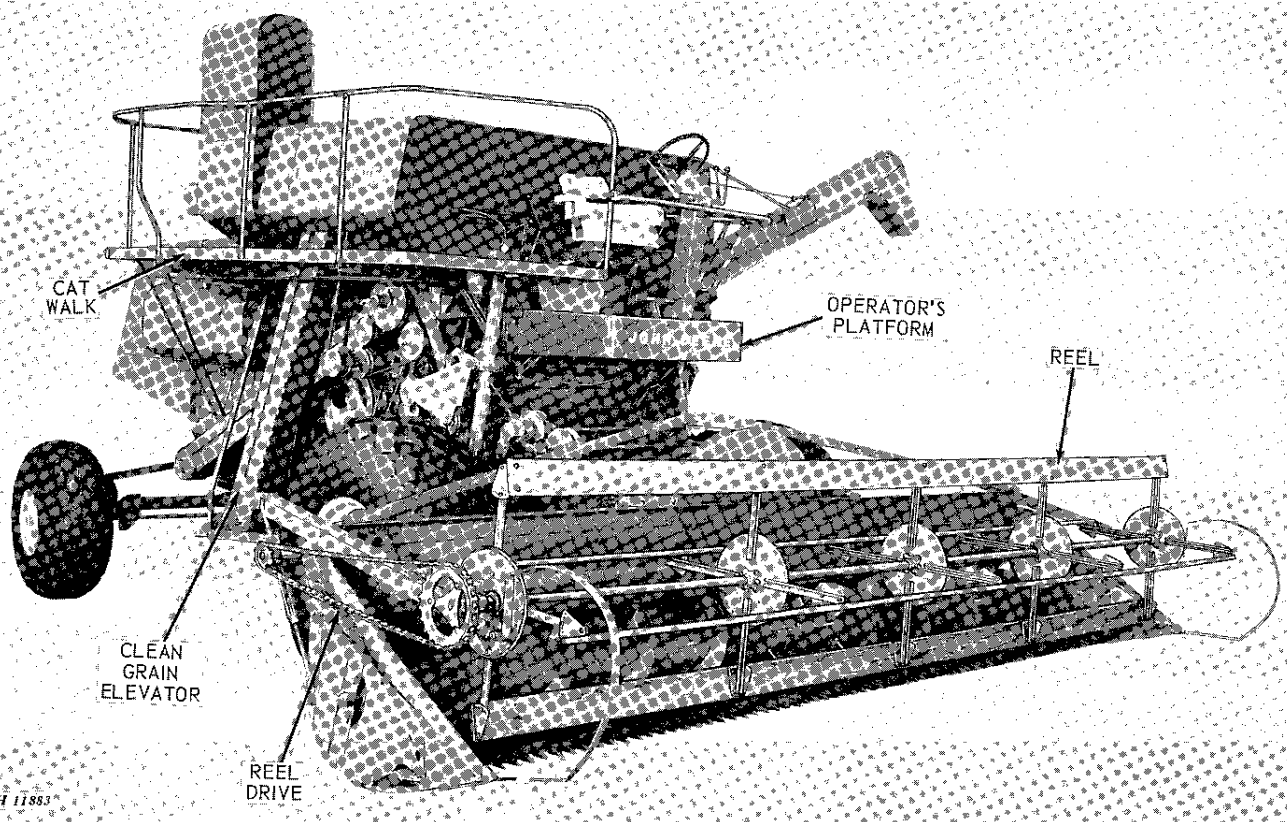
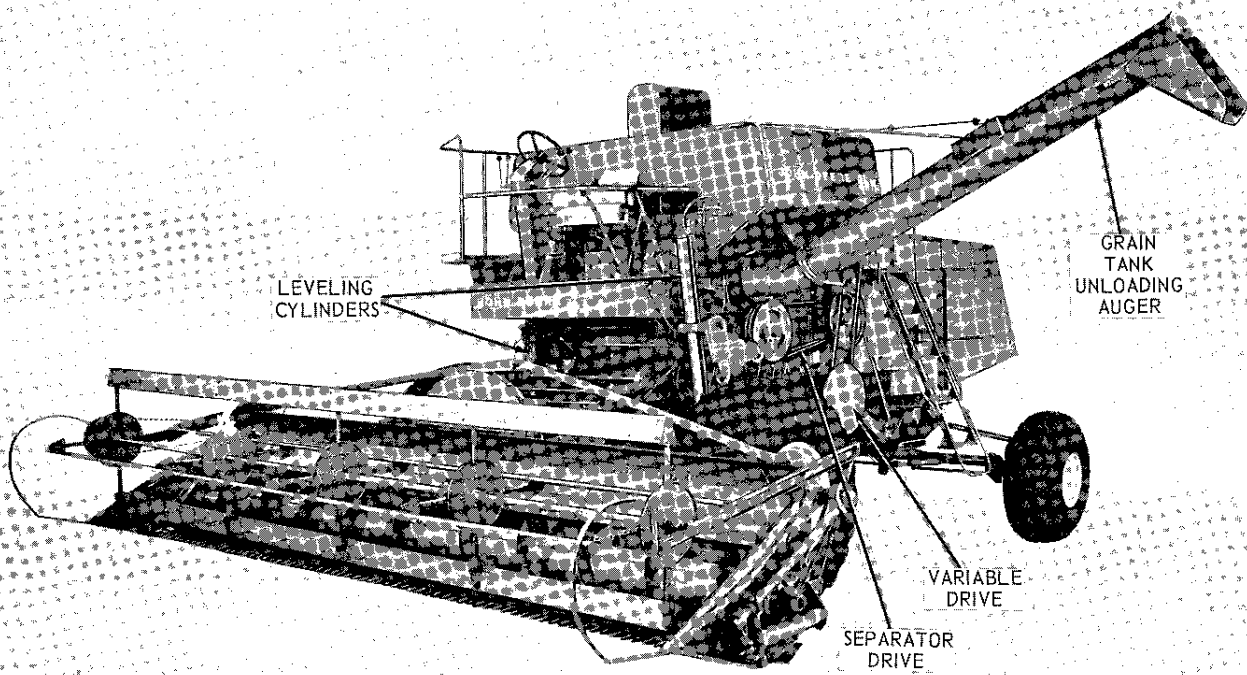

WHEEL TREAD DIMENSIONS	
Tire Size	Center-to-Center
23.1-26	112 inches
26.5-25	115-1/2 inches
18.4-16A	106 inches

TIRE INFLATION CHART		
Tire Size	Ply Rating	Pressure
18.4-16A (Low profile)	6	10 lbs.
23.1-26 (Low profile)	10	18 lbs.
26.5-25 (Low profile)	12	16 lbs.

**SELECTIVE GROUND SPEED CONTROL RANGE**

23.1-26 TIRES			26.5-25 TIRES		
	(Min.)	(Max.)		(Min.)	(Max.)
1st Gear . . . . .	.7 to	1.6 mph	1st Gear . . . . .	.8 to	1.8 mph
2nd Gear . . . . .	1.5 to	3.3 mph	2nd Gear . . . . .	1.6 to	3.7 mph
3rd Gear . . . . .	2.9 to	6.5 mph	3rd Gear . . . . .	3.3 to	7.4 mph
4th Gear . . . . .	5.8 to	13.1 mph	4th Gear . . . . .	6.6 to	14.8 mph
Reverse . . . . .	2.0 to	4.5 mph	Reverse . . . . .	2.3 to	5.1 mph

**ENGINE**

Make of engine . . . . . John Deere—HB 248-G  
 Bore . . . . . 3-7/8-in.  
 Stroke . . . . . 3-1/2-in.  
 Brake horsepower . . . . . 95\*  
 Number of cylinders . . . . . 6  
 Piston displacement . . . . . 247.67 cu. in.  
 Maximum load speed . . . . . 2,500 rpm  
 Firing order . . . . . 1-5-3-6-2-4  
 Crankcase . . . . . Cast integral with block  
 Type of lubrication . . . . . Force-feed by gear pump to all connecting rods, main bearings, governor, oil pump drive. Oil strainer in bottom of pan.  
 Valve arrangement . . . . . Valve-in-head (Rotators on exhaust valves)  
 Valve clearance:  
 Intake . . . . . 0.12-in. (cold)  
 Exhaust . . . . . 0.18-in. (cold)  
 Make of governor . . . . . Pierce

Make of carburetor . . . . . Zenith (Dual down draft type)  
 Distributor setting . . . . . .022-in.  
 Air cleaner . . . . . Dry type  
 Spark plug:  
 Size . . . . . 14 mm  
 Gap . . . . . .025-in.  
 Electrical system . . . . . 12-volt (Two 6-volt batteries)  
 Cooling system . . . . . Water pressure type  
 Type of fuel . . . . . Gasoline (regular grade)

**CAPACITIES (Approx.)**

Fuel tank . . . . . 60 U.S. gallons  
 Cooling system (Radiator) . . . . . 6 U.S. gallons  
 Engine crankcase . . . . . 4 U.S. quarts  
 Automatic leveling unit  
 (Including hydraulic oil lines and cylinders) . . . . . 18 U.S. quarts  
 Hydraulic unit  
 (Including lines and cylinders) . . . . . 12 U.S. quarts

\*Calculated at 60° F. and 29.92 of Hg. at sea level.

*(Specifications and design subject to change without notice.)*

#### 4 Specifications

### COMBINE DIMENSIONS—OVER-ALL

NOTE: Dimensions are for combine equipped with 23.1-26 (15-26) front tires and 18.4-16A rear tires.

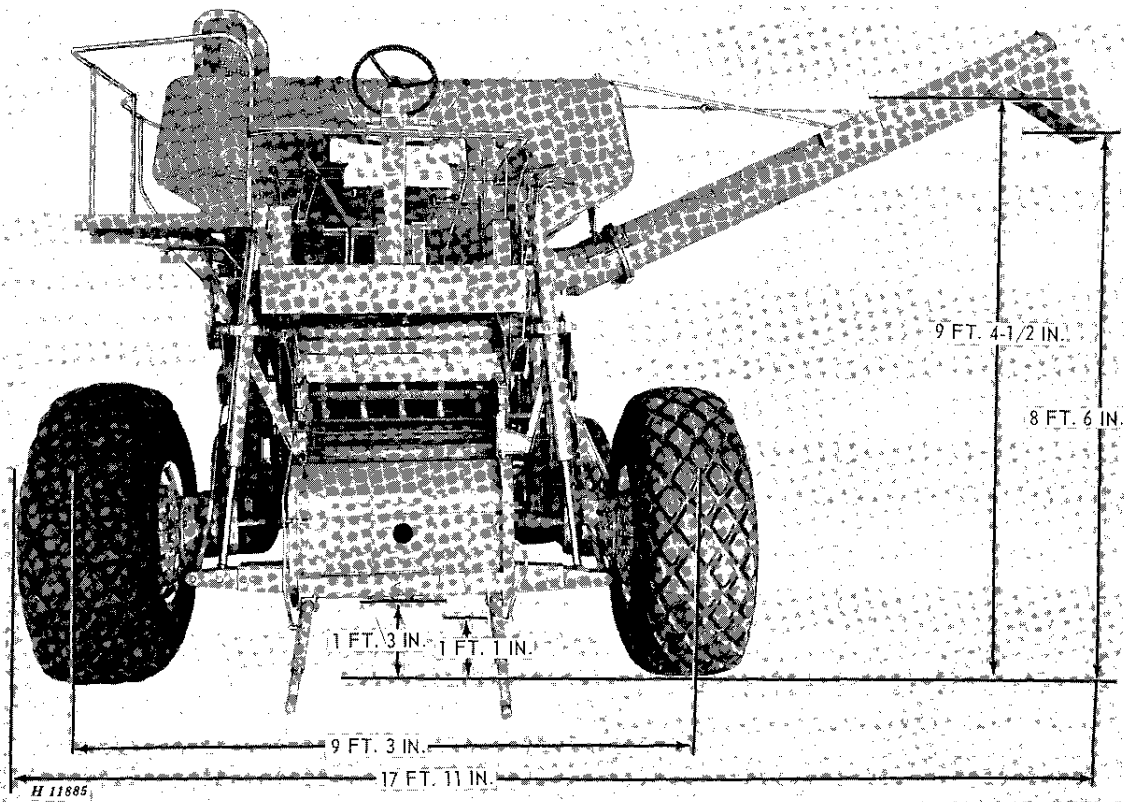
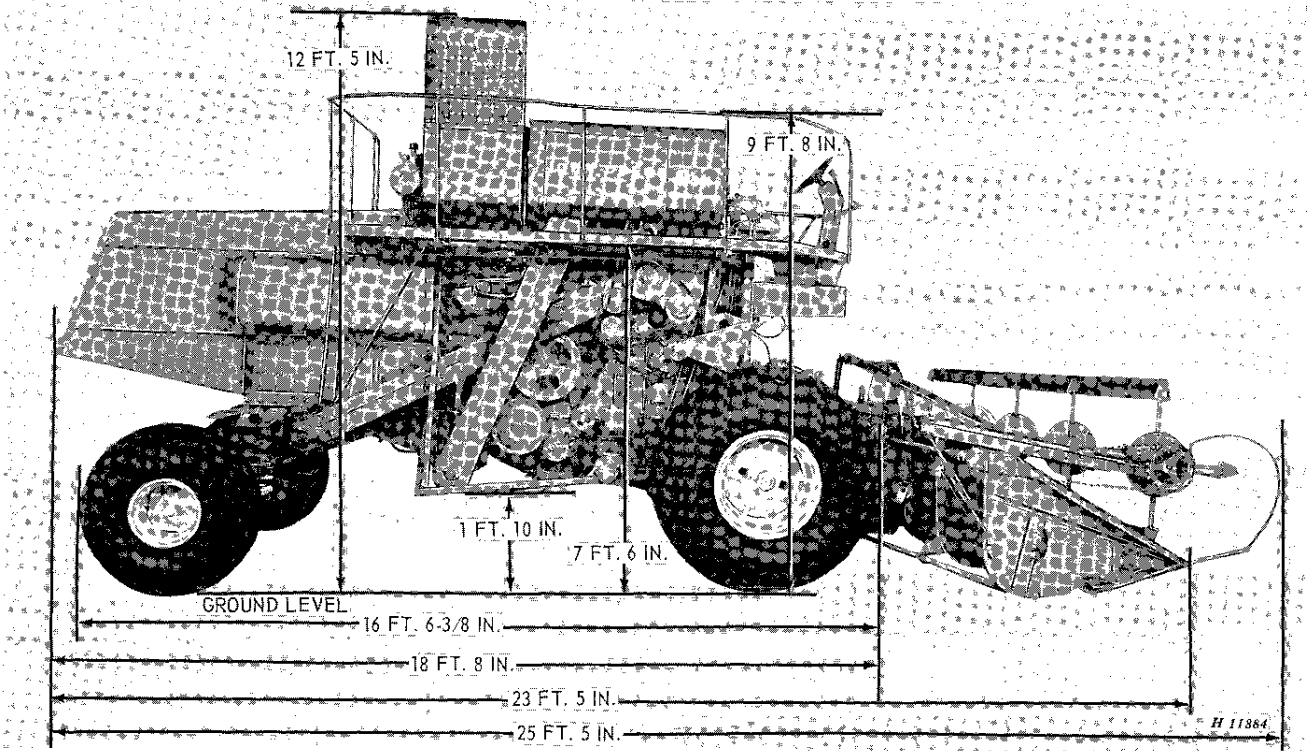



# CONTROLS AND INSTRUMENTS

Before attempting to operate your new combine, become familiar with the location and purpose of its controls and instruments. Study these pages carefully, regardless of your previous combine experience.

## CONTROLS

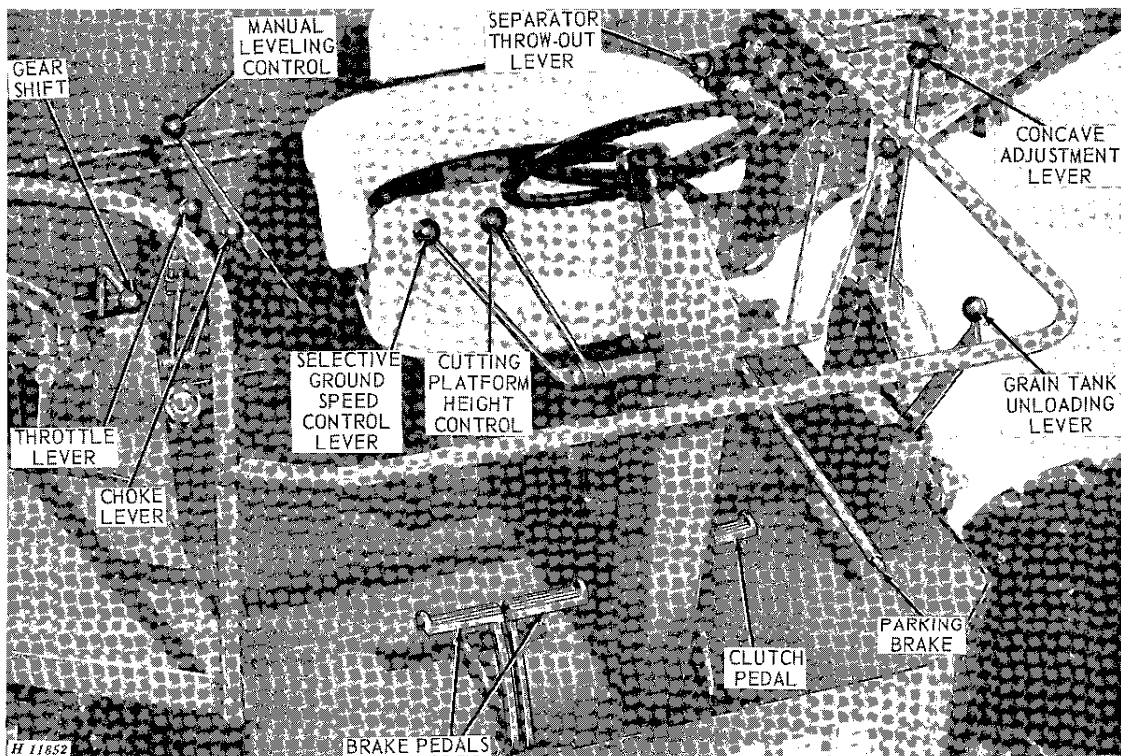

The combine controls are located on the operator's platform within easy reach of the operator. Those controls whose purpose and function are obvious, are not explained.

### TRANSMISSION GEARSHIFT LEVER

There are four speed ranges forward and one reverse range. Positions of gearshift lever for different transmission speed ranges are shown by diagram.



**CAUTION:** Be certain the gearshift lever is in neutral position before starting engine.

### GRAIN TANK UNLOADING LEVER

This lever engages auger when pulled rearward. To disengage, move lever forward. Grain tank unloading drive and separator drive are independent. If engine is running, separator can be stopped without affecting unloading of grain tank.

### SEPARATOR THROW-OUT LEVER

This lever is disengaged when in forward position. To engage, pull lever rearward.

## CONTROLS—Continued

### SELECTIVE GROUND SPEED CONTROL LEVER

To increase ground travel speed within a selected transmission range, move lever forward. It will automatically return to neutral position when released and speed will remain as selected.

### CUTTING PLATFORM HEIGHT CONTROL LEVER

This lever controls the height of the platform through a hydraulic mechanism. Move lever forward to lower platform; pull lever rearward to raise platform. When released, lever automatically returns to neutral position and cutting platform remains at selected position. As a safety measure, cutting platform height cannot be changed unless engine is running.

### CUTTING PLATFORM THROW-OUT SWITCH

This switch operates the electromagnetic throw-out clutch which permits instant stopping of the cutting platform and feeder while the separator continues to run.

Push the switch down to disengage drive. When trouble has been taken care of, push switch down again to engage drive.

### MANUAL LEVELING CONTROL LEVER

If the automatic leveling mechanism should fail to function, or if the operator desires to tilt the separator while on level land, the leveling mechanism can be controlled by means of the manual control lever. Move lever to right for right-hand tilt and to left for left-hand tilt.

### THROTTLE CONTROL LEVER

Move lever one quarter forward from rear to start engine. Move lever all the way rearward for slow idle; move lever all the way forward for normal operation.

### CHOKE CONTROL LEVER

Move lever all the way forward to start engine. After engine is started, and for normal operation, move lever all the way rearward.

### CONCAVE FRONT ADJUSTMENT LEVER

Move lever forward to open front of concave; move lever rearward to close front of concave. The normal maximum opening is one inch.

### PARKING BRAKE LEVER

The parking brake lever is used to lock the wheel brakes so the combine cannot move if left unattended. To engage, pull lever rearward. To disengage, move lever forward.

**Never attempt to move combine with parking brake lever engaged.**

### FLOW RESTRICTOR VALVE

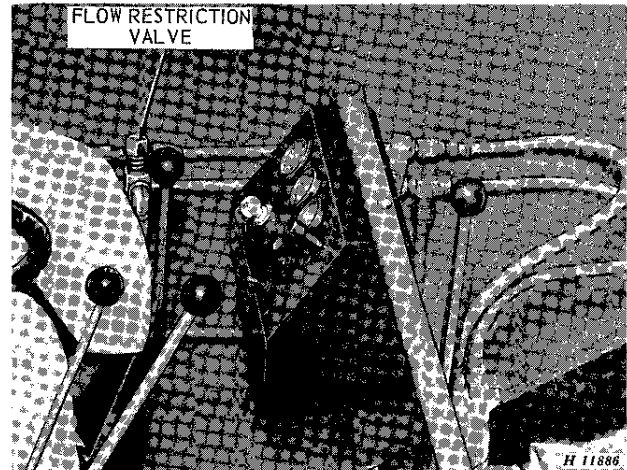

The flow restrictor valve controls the leveling speed. This valve can be adjusted from the operator's seat to give the desired leveling speed. The speed can be quickly changed to meet varying ground and slope conditions.

Turn the valve clockwise to slow down the leveling speed; turn valve counter-clockwise to increase the leveling speed.

The valve is color coded and numbered so that various speed adjustments can be made, changed, and reset by remembering the colors and numbers used.

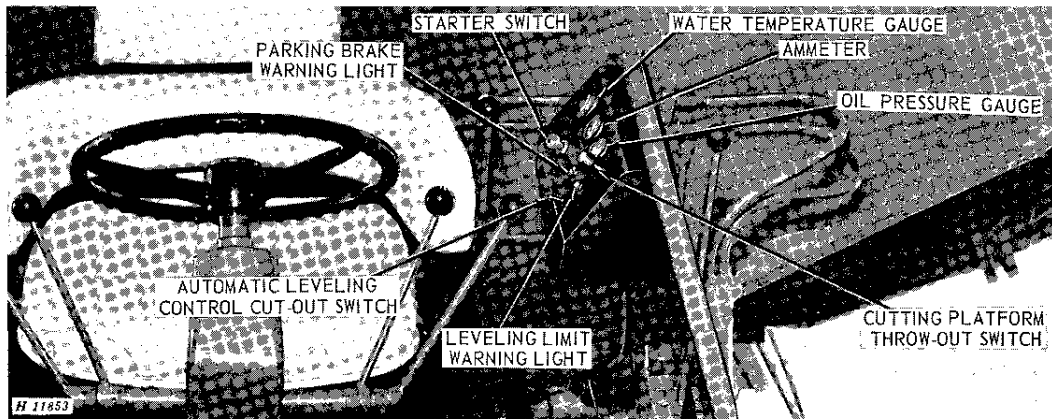

A locking set screw is provided so that the valve can be locked in one position if so desired. If the locking screw is not used, it is necessary to occasionally check the setting to be certain the valve is not "creeping," due to vibration.

**CAUTION:** When the flow is restricted any amount, extreme caution must be taken against excessive speed on steep slopes.

#### PARKING BRAKE WARNING LIGHT

When the parking brake is engaged, the warning light will flash on and off the instant the ignition switch is turned on. This is a precaution against moving the combine with the parking brake engaged.

#### LEVELING LIMIT WARNING LIGHT

This light will flash on and off when the separator has reached the automatic leveling limit; beyond this point, the separator will start to lean and the operator should proceed only with the utmost caution.

#### AMMETER

This gauge indicates the rate of charge or discharge of the batteries. If ammeter shows discharge for an extended period during normal

operation, check for a ground, short circuit, or faulty regulator. If ammeter show high charge continually, inspect for low batteries, faulty connections, low battery water, or bad regulator.

#### OIL PRESSURE GAUGE

This gauge indicates the pressure of engine lubricating oil. Oil pressure will vary slightly with wear, but with recommended oil, it should read normal (indicated by green band on dial) at full governed speed. If oil pressure drops (indicated by red band on dial), stop immediately and determine cause.

#### WATER TEMPERATURE GAUGE

This gauge indicates the water temperature in the cooling system—not the quantity. Normal operating temperature is 160° to 200°F (indicated by green band on dial). If 200°F or above (indicated by red band on dial), stop engine and determine cause.

#### AUTOMATIC LEVELING CONTROL CUT-OUT SWITCH

This switch enables the operator to disengage the automatic leveling control mechanism if so desired for various purposes such as transporting.



# OPERATION

## FUNDAMENTALS OF COMBINE HARVESTING

The most important factor in harvesting, is for the operator to have a thorough understanding of the fundamentals of combine operation.

These fundamentals in brief are:

Be sure crop is in condition to thresh—moisture content not too high—straw not too green, etc.

In making the first round of the field, keep the combine forward speed as slow as possible to reduce the volume of material entering the combine. Always run the engine at full throttle to keep the combine mechanism up to full speed, thus guarding against slugging and clogging. Use the selective ground speed drive to obtain slower speed or shift to a lower gear if necessary—but do not throttle down the engine.

Select a ground speed that will not overload the combine.

Engine should be in good condition—governor should be properly set and responsive enough to accelerate quickly if an overload occurs.

Keep the cylinder speed as low as possible and concave clearance as high as possible to remove the maximum amount of grain from head without breaking up the straw excessively. Maintain correct beater speed to guard against wrapping of straw on beater.

Cut the crop as high as possible without excessive loss of low grain heads. If the crop is down and tangled, it may be desirable to use lifting guards. Slow travel speed is imperative.

Adjust the reel position and speed for even feeding.

Regulate adjustable chaffer openings to pass the grain or seed to the lower sieve before it has passed over two-thirds the length of chaffer without admitting too much coarse material.

Close adjustable sieve as far as possible without carrying clean grain into the tailings auger.

If material loads up on front of chaffer, adjust upper windboard to throw air blast to front of shoe.

Use as much air as possible without blowing over clean seed. If the grain or seed is unusually light, it may be necessary to reduce the volume

of air. In heavy seeds, increase the volume of air.

Keep amount of tailings as low as possible.

## FUNDAMENTALS OF AUTOMATIC LEVELING

The automatic leveling control switch actuates the leveling mechanism, allowing the separator to be held level while the wheels conform to the contour of the hill.

When the combine has reached the limit of its automatic leveling capacity, approximately 42 per cent, the limit switch cuts in an electrical circuit to a flasher light on the instrument panel. The light will continue to flash on and off as long as the arm on the axle pivot contacts the limit switch plunger. This indicates to the operator the limit of leveling has been reached, and beyond this point, the separator will start to lean.

When the ignition switch is turned off, the automatic leveling will not function.

## OPERATING SUGGESTIONS

Don't start combining until the crop is ripe.

Unless crop drying equipment is available, a crop should not be combined until it is dead ripe. If the threshed grain feels damp or is easily dented with the fingernail, the moisture content is usually too high for safe storage.

Grain crops containing 14 per cent moisture or less are usually considered dry enough for safe storage. A John Deere Moisture Meter for checking moisture content of grain and a portable Grain Dryer can be purchased from your John Deere dealer, or arrangements can usually be made at the local grain elevator for necessary moisture tests and drying if necessary.

## OPERATION IN WEEDY CONDITIONS

Combining in fields where weeds are numerous is particularly troublesome as they tend to gum up the sieves. Also, the moisture in the seeds is imparted to the grain.

The following suggestions will help while operating in weedy conditions.

Cut the crop as high as possible to avoid weeds and undergrowth.

Check to see that the cylinder is operating at proper speed.

Use as much air blast on the shoe as possible without blowing over grain.

Lower rear end of chaffer.

### STARTING THE ENGINE

Make certain the separator, cutting platform, and grain tank unloading auger throw-out levers are disengaged and transmission is in neutral.

If engine has not been operated for a period of time, or the fuel tank has run dry, prime fuel pump lever up and down to force gasoline into carburetor.

*NOTE: After priming fuel pump, be sure the priming lever is in the "down" position. If the priming lever is left in the "up" position, the fuel pump is inoperative.*

Move throttle lever one-quarter forward from rear. Move choke lever all the way forward; then turn key as far clockwise as possible. After engine starts, release key, push choke control rearward. Set engine at slow idle speed by moving throttle lever all the way rearward.

Make certain oil pressure gauge is registering pressure.

Do not place engine under load until it is properly warmed up.

### STARTING THE COMBINE



**CAUTION:** Make certain no one is standing near enough to the combine to touch any moving parts. Warn everyone to stand clear.

When engine is properly warmed up, move separator throw-out lever forward to engage the separator. Push throttle lever all the way forward.

Check the speed of beater behind the cylinder with a speed indicator. Beater should operate at 680 to 685 rpm with separator empty and not under load. If beater speed is not correct, adjust governor setting (see page 79).

Test operation of hydraulic control for adjusting cutting platform height.

Test operation of grain tank unloading auger.

Test operation of hydraulic selective ground speed control.

Check brakes to see if they are in proper working order.

Inspect entire combine again, making certain all units are working properly.

Disengage separator, then close doors at bottom of elevators.

### SELECTING PROPER GROUND SPEED

The ground speed of the combine can be very closely controlled by using the selective ground speed drive in conjunction with different transmission speeds. The chart on page 3 shows the range of speeds that can be obtained in each transmission range by means of selective ground speed control. Select the best transmission speed range; then, with the selective ground speed control lever, adjust the ground speed to meet field conditions exactly.

### SPEEDS OF VARIOUS UNITS (FAST IDLE—NO LOAD)

Auger, platform . . . . .	176 rpm
Beater behind cylinder . . . . .	680 to 685 rpm
Beater, front of feeder house . . . . .	161 rpm
Cylinder, regular . . . . .	816 rpm
Cylinder (extreme low) . . . . .	196 rpm
Cylinder (extreme high) . . . . .	1,190 rpm
Elevators . . . . .	313 rpm
Fan (normal operating speed) . . . . .	750 rpm
Fan (extreme low) . . . . .	602 rpm
Fan (extreme high) . . . . .	858 rpm
Feeder house conveyor drive shaft . . . . .	231 rpm
Grain conveyor under cylinder:	
(with regular 15-tooth sprocket) . . . . .	170 rpm
(with special 10-tooth sprocket) . . . . .	255 rpm
Ground travel speeds . . . . .	See page 3.
Reel . . . . .	19.1 to 50.5 rpm
Shoe crank . . . . .	286 rpm
Straw walker . . . . .	213 rpm

**SUGGESTED SETTINGS FOR COMBINING VARIOUS CROPS**

*(These suggested settings are for average conditions. Different field conditions may make it necessary to change these settings.)*

Crop	Cylinder Rpm	Cylinder to Concave Clearance		Type of Cleaning Sieve	Setting of Adjustable Cleaning Sieve	Setting of Adjustable Chaffer	Setting of Adjustable Cleaning Fan Sheave	Fan Side Shutter Opening	Grain Conveyor Inserts (Special Attachments)
		Front	Rear						
Alfalfa	1057	3/16"	1/8"	Adjustable or 1/10" round hole	Slightly open	1/8 open	Closed	Closed	0.050" round holes
Barley— Feed and Malting	1057 or 952	1/2"	1/4"	Adjustable	1/3 to 1/2 open	1/2 to 1/3 open	Halfway open	1/2 open	0.165" triangle holes
Beans— Edible	277 or 413	1/2" to 3/4"	1/4" to 1/2"	Adjustable	1/2 open	Nearly wide open	1/2 open	Open	3/32"x3/4" slotted
Beans— White Pea	466 or 525	1/2"	1/4"	Adjustable	1/2 open	2/3 open	1/2 to 3/4 open	Open	5/32" round holes
Clover— Most Varieties	1057	3/16" to 5/32"	1/8" to 1/16"	Adjustable or 1/10" round hole	Slightly open	1/4 to 2/3 open	Closed	Closed	0.050" round holes
Grass— Most Varieties	1057 or 881	3/16"	1/8"	Adjustable or 5/32" round hole	1/4 to 1/3 open	1/2 to 2/3 open	Closed	Closed	0.050" round holes
Mustard	1057 or 765	3/8"	1/4"	Adjustable	1/4 to 1/3 open	2/3 open	1/3 to 1/2 open	Closed	0.070" round holes
Oats	1057	5/16"	3/16"	Adjustable	1/3 to 1/2 open	3/4 open	1/3 to 1/2 open	1/2 open	0.125" triangle
Peas— Field	453	1"	3/4"	Adjustable	1/3 open	2/3 open	1/2 to 3/4 open	Open	3/32"x3/4" slotted
Peas— Scotch Green	453	1"	3/4"	Adjustable	1/3 open	2/3 open	3/4 to wide open	Open	3/32"x3/4" slotted
Peas— Willets Wonder	453	1"	3/4"	Adjustable (preferred) or 3/8" round hole	1/3 open	2/3 open	1/2 to 3/4 open	Open	3/32"x3/4" slotted
Proso or Hog Millet	793 or 850	3/16"	1/8"	Adjustable or 5/32" round hole	Slightly open	1/2 open	1/3 to 1/2 open	1/3 open	0.050" round holes
Rye	1057	5/16"	1/4"	Adjustable	1/3 open	2/3 open	Closed to 1/3 open	1/2 open	0.165" triangle holes
Safflower	544	1/2"	3/16"	Adjustable	1/2 open	3/4 open	1/2 open	3/4 open	0.165" triangle holes
Timothy	1057	5/32"	1/16"	Adjustable or 1/10" round hole	Slightly open	1/2 open	Closed	Closed	0.050" round holes
Wheat	1057	5/16"	3/16"	Adjustable	1/3 to 1/2 open	2/3 open	Halfway open	2/3 open	0.165" triangle holes

*See cylinder speed chart for sprocket combinations - page 47.*

## TRANSPORTING

When transporting, drive combine under its own power, or load it on a truck. Combine may be towed with caution. If combine is to be towed, remove the drive shafts from between final drives and differential.

This combine is designed for easy and safe transporting. The width of the combine can be reduced by folding the hinged unloading auger back along the separator and removing the cutting platform. The radiator screen can be removed to reduce the height.

Over-all dimensions are given on page 4.

Make certain the automatic leveling control switch is in off position when transporting.

If the cutting platform is removed, the hydraulic cylinders must be wired no closer to the separator support channel than 14 inches, as damage may result to hoses if carried too close.

When transporting combine on a truck, block up the leveling cylinders with angle iron to prevent combine from tilting, causing possible damage.

Clean out the combine thoroughly before leaving one field and going to the next in order to reduce the spread of noxious weed seeds.

Before moving to the next field sweep trash and straw from outside of combine, open doors at bottom of elevators and run combine until all straw, trash, and grain are removed from inside of combine.



**CAUTION:** When driving the combine on a road or highway at night or during the day, use accessory lights and devices for adequate warning to the operators of other vehicles. In this regard check local governmental regulations. Various safety lights and devices are available at your John Deere dealer's.

## COLD WEATHER OPERATION

Operating a combine in cold weather requires special preparation. If proper precautions are

taken, the combine will give just as good service as when operating under normal conditions.

## HYDRAULIC UNITS AND CRANKCASE

Use the grade of oil recommended in the lubrication chart, page 17. Lubricants of the correct viscosity are necessary for proper protection.

## TRANSMISSION CASE AND FINAL DRIVES

SCL multipurpose type SAE 90 gear oil is recommended for year round use.

## FUEL SYSTEM

Use winter-grade gasoline. Fill the fuel tank at the end of the day's run to prevent moisture from condensing in the fuel tank.

## COOLING SYSTEM

When the temperature is likely to be 32° F. or lower, there is danger of the water freezing in the cooling system. To prevent this, either drain the cooling system at the end of each day's run, or use an antifreeze solution. The use of antifreeze is recommended.

The following chart gives the quantity of antifreeze to be added to protect the cooling system.

Do not use alcohol as an antifreeze if other materials are available. Denatured alcohol boils at 173° F. If alcohol must be used, check it frequently to maintain the proper mixture for the expected temperature.

**CAUTION:** Never use calcium chloride solution in the radiator. It is harmful to metal parts.

Quarts of Antifreeze to be Used			
Lowest Expected Temperature	Denatured Alcohol	Methanol	Ethylene Glycol
+20° F.	4-1/2	3	4
+10° F.	6-1/2	5	6
0° F.	8	6-1/2	8
-10° F.	9-1/2	8	9-1/2
-20° F.	11	9	10-1/2

## 12 Operation

### BATTERIES

When the temperature drops below freezing, take precautions to avoid damage to the battery cells from freezing. A badly discharged battery freezes more quickly than one that is well charged. For example, a battery with a specific gravity reading of 1.175 (discharged) will freeze at 4° F., and a battery with specific gravity reading 1.300 (fully charged) will not freeze until the temperature reaches -65° F.

In freezing weather, do not add water to the batteries unless engine is going to be run. Water will readily freeze as it will not mix with the electrolyte until the generator passes a charging current through the batteries.

### END OF SEASON SERVICE

When the combining season is finished, the combine should be stored until the next season. Follow the suggestions on these pages to be certain your combine is ready to go when the next season starts.

### ENGINE

Wash the outside of the engine thoroughly. Use diesel fuel and a stiff brush.

Drain the crankcase, refill with fresh oil and run the engine at idling speed for 15 to 20 minutes. Be sure to leave oil in crankcase while combine is stored.

Drain and refill both of the hydraulic systems with clean oil. Do not leave hydraulic system dry while combine is stored.

Clean inside of air cleaner, remove loose dirt from filter and install filter in air cleaner.

Operate engine another 10 to 15 minutes, using WHITE (non-leaded) gasoline.

Use an oil, produced by a reputable refinery, to condition the combustion chambers of the engine for storage. Either flood the engine with this oil or introduce the oil through spark plug openings, depending upon the oil manufacturer's recommendations.

*NOTE: Only regular oil is required in crankcase.*

Drain all gasoline from tank and carburetor. Leave drain valves open.

**CAUTION:** If gasoline is allowed to stand in tank, fuel lines, fuel pump, and carburetor, a gummy substance will form in carburetor jets and passages. This gum is difficult to remove and will cause future trouble.

Either drain water from radiator and engine block leaving out drain plugs so water, that might condense in cooling system, can drain out or use an antifreeze solution to protect the cooling system for the lowest temperature expected.

Seal exhaust opening, crankcase breather, and hydraulic oil reservoir breather with sealing tape to prevent entrance of moisture or foreign material.

If combine is stored in the open, remove batteries and store them in a cool, dry place where temperature will stay above freezing. Do not place batteries on a concrete floor as cold tends to draw strength from the batteries. Check and recharge the batteries every 30 days to prevent damage to the plates.

Remove radiator screen and shield and clean out any dust or dirt accumulated in the radiator core. Use air or water, under pressure, for this purpose.

### COMBINE

If possible, shelter the combine in a dry place.

Clean the combine thoroughly inside and out. Chaff and dirt will draw moisture, rot wood parts, and rust the steel.

Remove belts. Clean belts, wrap them in burlap, and store in a cool, dark place. Clean chains thoroughly and brush fairly heavy oil on chains to prevent corrosion.

Clean out augers and elevators. Leave doors open at bottom end of elevators.

Clean out bottom of grain tank and unloading auger.

Clean the chaffer and sieve.

Grease feeder house conveyor bottom so it will not rust.

Lubricate combine completely. See Lubrication Charts. Grease the threads on bolts used for adjustments. Apply a coating of grease to slip clutch jaws.

Paint all parts from which paint has worn.

Support cutting platform with blocks to level it.

Block up combine, taking load off tires. Do not deflate tires. If combine is stored outside, remove wheels and tires and store in a cool, dark, dry place.

Block clutch pedal in disengaged position to prevent damage to clutch plates during storage.

Release spring tension on slip clutches.

Put a few drops of SAE 10W oil on four face plate studs of cutting platform electromagnetic throw-out clutch.

List the repairs that will be needed before the next season and order them early. Your John Deere dealer can give better service during the off season, and when parts are received, they can be installed in your spare time—no delay at harvest time.

Coat leveling cylinders completely with grease so they will not rust.

### **BEGINNING THE SEASON SERVICE**

The combine must be taken out of storage and carefully checked before starting the next harvest season. By making sure your combine is in tip-top shape, you can avoid costly breakdowns during the harvest season.

Replace wheels if they were removed and remove blocking. Check tire inflation.

Clean the combine thoroughly inside and out.

Clean and adjust spark plugs. Replace worn or oil-soaked wiring.

Install the batteries. Check electrolyte level and recharge batteries.

Flush radiator, reinstall drain plugs, and refill with clean water; use rain water if obtainable. Do not use water containing alkali.

Remove sealing tape from all engine openings.

Clean all fuel lines and fuel strainers. Blow out carburetor jets with air. Never use a wire.

Install belts, making sure they have the proper tension.

Adjust chains to proper tension. Be sure to check chains in clean grain and tailings elevators.

Clean slip clutches. Be sure to put grease in bore of slip clutches after cleaning.

Adjust spring tension on slip clutches.

Close elevator doors.

Fill fuel tank.

Lubricate combine completely, then run combine at half-speed for about an hour. Check bearings for overheating or excessive looseness. Be sure slip clutches operate freely.

Go over complete combine and see that all bolts are tight and cotter pins are in place.

Review your operator's manual.

### ATTACHING CUTTING PLATFORM

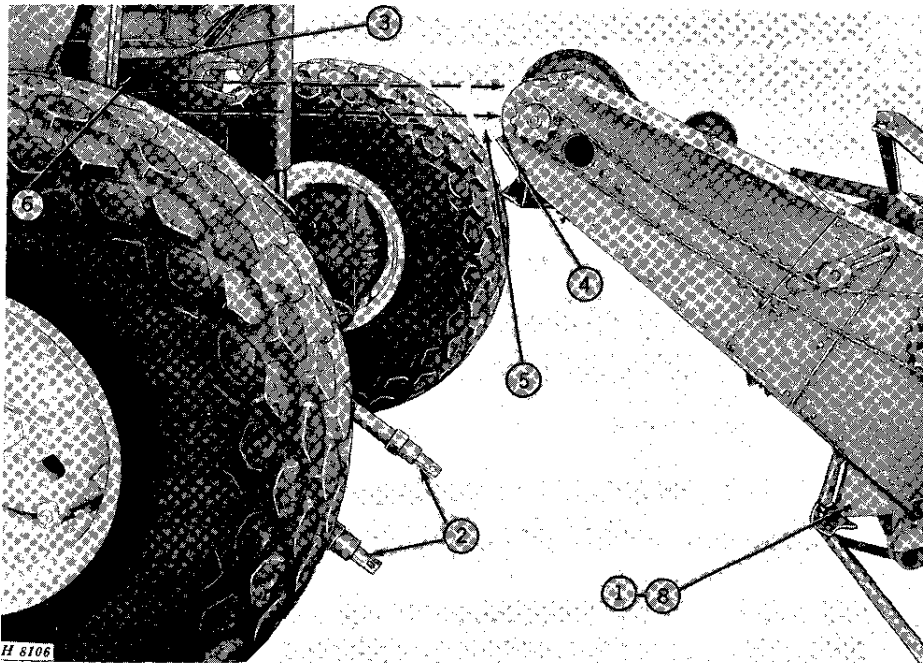

1. Block up platform under hinge brackets.
2. Wire up hydraulic cylinders.
3. Remove the cylinder front door and the lower grain conveyor front door.
4. Raise feeder house hinged plate.
5. Drive separator forward and secure feeder house in pivot brackets on separator with retainers, pins, and cap screws.
6. Install the cylinder front door and the lower grain conveyor front door.
7. Attach hydraulic cylinders to hinge brackets.
8. Remove blocking.

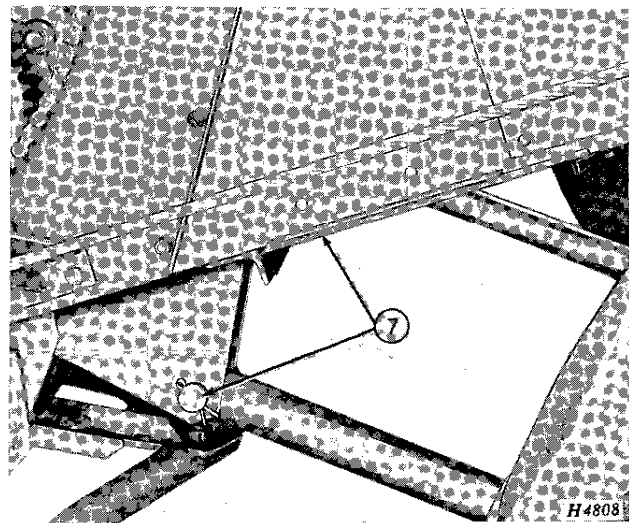

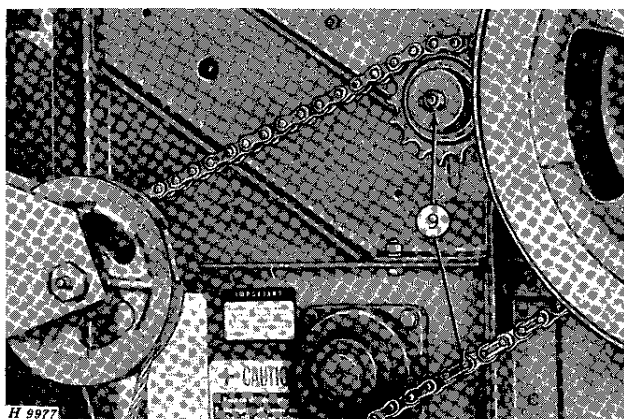

9. Install platform drive chain and adjust chain tension. (See page 67.)

10. Attach platform leveling cables at turnbuckles. (One each side.)

To remove cutting platform, block up platform under hinge brackets. Remove the cylinder front door and the lower grain conveyor front

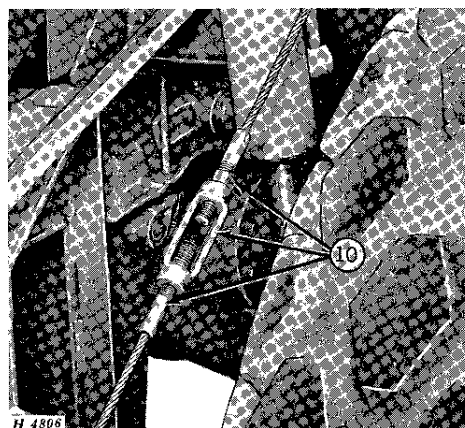

door. Detach platform leveling cables at turnbuckles. Remove platform drive chain, pins from hydraulic cylinders, and pins from pivot brackets on separator. Drive separator rearward slowly until front of separator clears rear of feeder house. Wire up hydraulic cylinders, install the cylinder front door and the lower grain conveyor front door.

### CUTTING PLATFORM LEVELING ADJUSTMENT

To insure satisfactory performance, the cutting platform must be parallel with the ground line of the main drive wheels. This should be checked periodically.

The combine should be located on flat, level ground when making the adjustment. However, if necessary, the adjustment can be made, exercising extreme caution, when the combine is on a hillside.

**IMPORTANT:** Main drive wheel tires must be inflated to equal tire pressure, otherwise an accurate cutting platform leveling adjustment cannot be made.

Adjust cables equally at the turnbuckles, until the cable springs are compressed approximately  $\frac{3}{8}$  of an inch, making the compressed length of each spring approximately  $3\frac{5}{8}$  inches.

Adjust the cables by loosening and tightening turnbuckles until the cutting platform is parallel with the ground.

*NOTE:* When removing cutting platform from the separator, be certain to disconnect front and rear cables at the turnbuckles.



*NOTE:* When harvesting peas, it may be desirable to loosen tension on the platform leveling cables to prevent damage to cable sheave supports when the platform is riding on the ground.

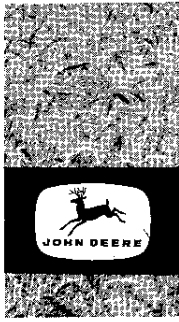

# SAFETY SUGGESTIONS

The safety of the operator was one of the prime considerations in the minds of John Deere engineers when this combine was designed. Shielding, simple adjustments, and other safety features were built into the combine wherever possible.

However, investigation of thousands of farm accidents show that careless use of farm machinery causes nearly 1/3 of all farm accidents. You can make your farm a safer place to live and work if you observe the safety suggestions given. Study these suggestions carefully and insist that they be followed by those working with you and for you.

All machinery should be operated only by responsible persons who have been delegated to do so.

Only the operator should be allowed on the operator's platform when the combine is in operation.

Never clean, oil, or adjust the combine when it is running.

Refill the radiator only when the engine is stopped or idling slowly. This combine has a pressure cooling system. To avoid being scalded when radiator cap is removed, first turn cap slightly to the stop which allows steam to escape through the overflow pipe. After all pressure is relieved, remove cap.

Refuel your combine only when the engine has been shut off. Do not smoke or use an oil lantern when refueling.

Keep the engine clean of chaff and straw to prevent the possibility of fires.

Have a fire extinguisher handy. It's a good idea to mount one on the operator's platform.

Replace badly frayed or worn belts before they break.

Clothing worn by combine operator should be fairly tight and belted. Loose jackets, skirts, shirts, or sleeves should never be worn because of the danger of getting into moving parts.

Be sure the gearshift lever of your combine is in neutral before starting the engine.

Keep the operator's platform clean. Do not use it as a place to carry loose tools, lunch boxes, etc.

Be sure shields and guards are in place and in good condition before starting in the field.

Combine brakes should be properly adjusted.

Always keep the combine in gear when going down hills.

Provide a first-aid kit for use in case of accident, and use proper antiseptics on scratches, cuts, etc., without delay, to prevent the possibility of infection.

Use the handrail when mounting the combine.

Make sure everyone is clear of the combine before starting so they cannot be struck by moving parts or caught in a drive belt or chain.

Never attempt to clear obstructions off the cutting platform unless the combine is stopped and the engine shut off.

Fold the unloading auger when transporting. When moving on a highway, keep as far to the right as possible. When driving the combine on a road or highway at night or during the day, use accessory lights and devices for adequate warning to the operators of other vehicles. In this regard, check local governmental regulations. Various safety lights and devices are available from your John Deere dealer.

Check your local governmental regulations regarding adequate warning devices.



**Suggest:**

**If the above button click is invalid.**

**Please download this document**

**first, and then click the above link**

**to download the complete manual.**

**Thank you so much for reading**

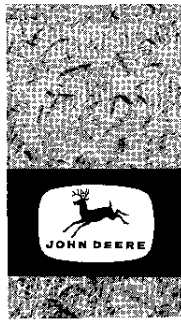

# LUBRICATION AND PERIODIC SERVICE

## BEARINGS

Two types of sealed bearings are used on this combine. One type is a sealed bearing which requires no lubrication; the other type is prepacked at the factory and will require yearly lubrication.

To lubricate bearings where a pipe plug is provided in bearing housing, remove the pipe plug and insert a 1/8-inch slotted grease fitting (JD7805); the slotted fitting allows the bearing housing to be filled to capacity without blowing out seals due to pressure building up. Then remove grease fitting and replace pipe plug.

Where no end cap or pipe plug is provided in the bearing housing, it will be necessary to pull bearing housing from shaft to repack bearing with new grease. Clean bearing and pack with new grease. Replace bearing housing.

## GREASES

SAE multipurpose grease is recommended for all grease fittings and handpacking points on your combine and its optional equipment.

## LUBRICATING OILS

It is recommended that oil used for this combine be suitable for service MS. Buy only nationally known brands of oil.

Depending upon the prevailing air temperature, use the following viscosity of oil in the engine crankcase.

Air Temperature	Single-Viscosity Oil	Multi-Viscosity Oil
Above 90° F.	SAE 30	SAE 20W-40
32° F. to 90° F.	SAE 20	SAE 10W-30
-10° F. to 32° F.	SAE 10W	SAE 10W-30
Below -10° F.	SAE 5W*	SAE 5W-20

\*Use of SAE 5W oil may cause some increase in oil consumption. Check oil level more often when using this oil.

Use the following viscosity of oil in the hydraulic oil reservoirs.

Air Temperature	Single-Viscosity Oil	Multi-Viscosity Oil
Above 32° F.	SAE 20	SAE 10W-30
Below 32° F.	SAE 10W	SAE 10W-30

## BREAK-IN

After 20 hours of operation, drain engine crankcase oil, replace crankcase oil filter, and fill crankcase with 7 U.S. quarts of service MS engine oil of the proper viscosity as shown in chart. Thereafter, drain and replace crankcase oil and oil filter every 200 hours of operation or every season (whichever comes first), using the correct oil as specified, in the chart.

Also, after 20 hours of operation, drain oil from hydraulic unit reservoir and leveling system reservoir. Remove the oil filters and clean in diesel fuel. Replace the oil filters and fill the reservoirs with service MS engine oil as shown in the chart. Thereafter, drain and replace oil and oil filter element every 500 hours of operation.

Lubricate the straw walker bearing blocks with SAE multipurpose grease after the first 5 hours of operation for the first three days; then every 250 hours of operation or every season (whichever comes first).

After the first 50 hours of operation, drain oil from transmission and final drives and fill with SCL multipurpose-type SAE 90 gear oil. Thereafter, drain and refill every 150 hours of operation or every season (whichever comes first).

**<https://www.ebooklibonline.com>**

Hello dear friend!

Thank you very much for reading.

Enter the link into your browser.

The full manual is available for immediate download.

**<https://www.ebooklibonline.com>**