

JOHN DEERE 95 H COMBINE



OPERATORS MANUAL JOHN DEERE 95 H COMBINE

OMH65203 A8 English

OMH65203 A8

LITHO IN THE U.S.A.
ENGLISH



TO THE PURCHASER

The combine you have purchased has been carefully designed and manufactured to provide years of dependable, economical service.

To further insure trouble-free service we recommend that you follow closely all instructions concerning operation, lubrication, adjustments and service. Preventive maintenance has proved to be much more economical than corrective maintenance. Should you require information not covered in this manual, consult your John Deere dealer.

KEEP YOUR COMBINE A JOHN DEERE COMBINE.

Genuine John Deere Parts fit properly and insure satisfactory service because they are made from the original patterns and from the same materials as used in new machines. If your combine requires replacement parts, go to your John Deere dealer where you can obtain Genuine John Deere Parts—accept no substitutes.

ATTACHMENTS

In addition to the equipment furnished with your combine, there are attachments available to help you do a better job of combining in a special crop or condition. These attachments, illustrated and described in the Attachment section, are available from your John Deere dealer.

LOCATION REFERENCE

"Right-hand" and "left-hand" sides are determined by facing in the direction the combine will travel when in use.

Radiator end of the engine is referred to as the "front," flywheel end as the "rear."

SERIAL NUMBERS

Your combine, cutting platform, axle, and engine have serial numbers.

When ordering parts, always bring with you the model and serial numbers as given on the serial number plates. By doing so, you will assist your John Deere dealer in giving you

prompt, efficient service. For your convenience a space is provided below for recording these numbers.

The combine serial number is on a plate located on the support bracket at the rear end of the fuel tank.

The engine serial number is on a plate located above the starter.

The axle serial number is on the top, left-hand side of the leveling beam support.

The cutting platform serial number is located on the right-hand side sheet.

Combine Serial No. _____

Engine Serial No. _____

Axle Serial No. _____

Cutting Platform Serial No. _____

Date Purchased _____

CONTENTS

	Page
Specifications	2
Controls and instruments.	5
Operation	9
Operating speeds and settings.	16
Safety suggestions.	19
Fuels and lubricants	20
Lubrication and periodic service.	22
Adjustments and service	44
Trouble shooting	102
Attachments	116
Index	120

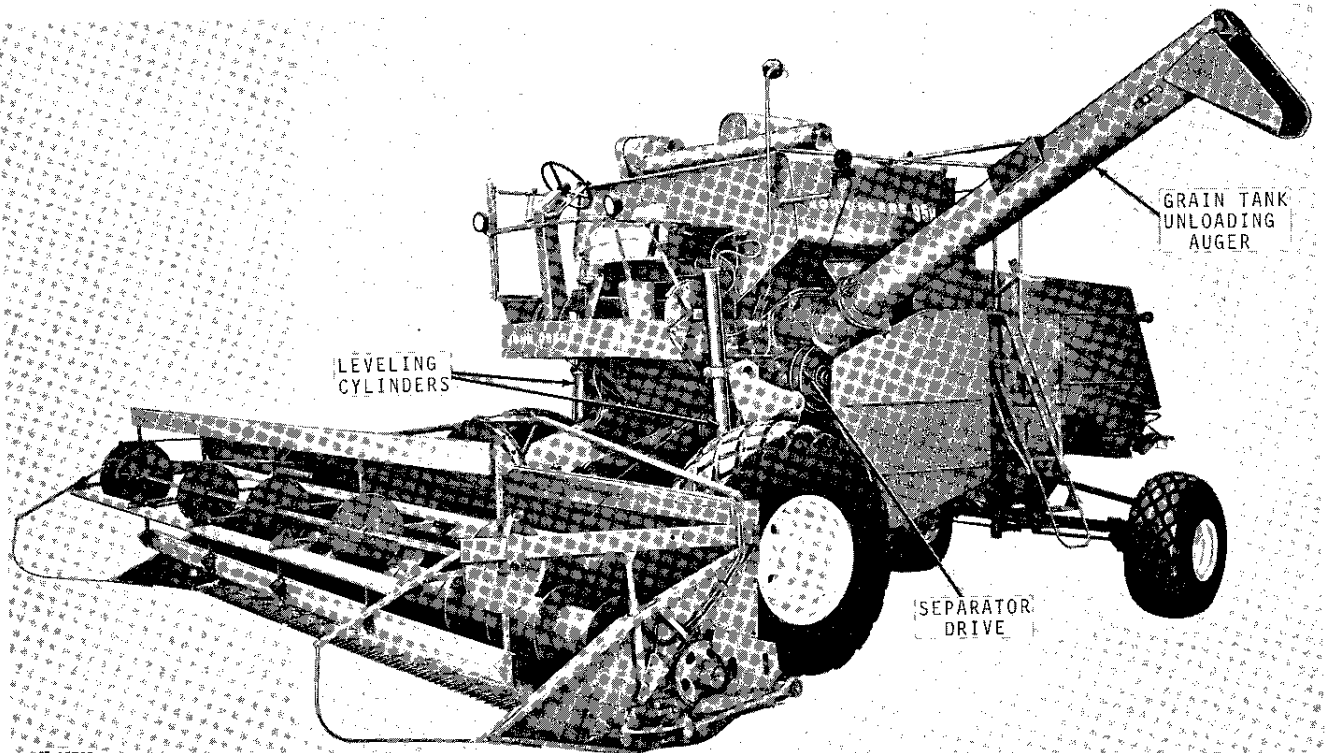

LEVELING CYLINDERS

GRAIN TANK UNLOADING AUGER

SEPARATOR DRIVE

H 15702

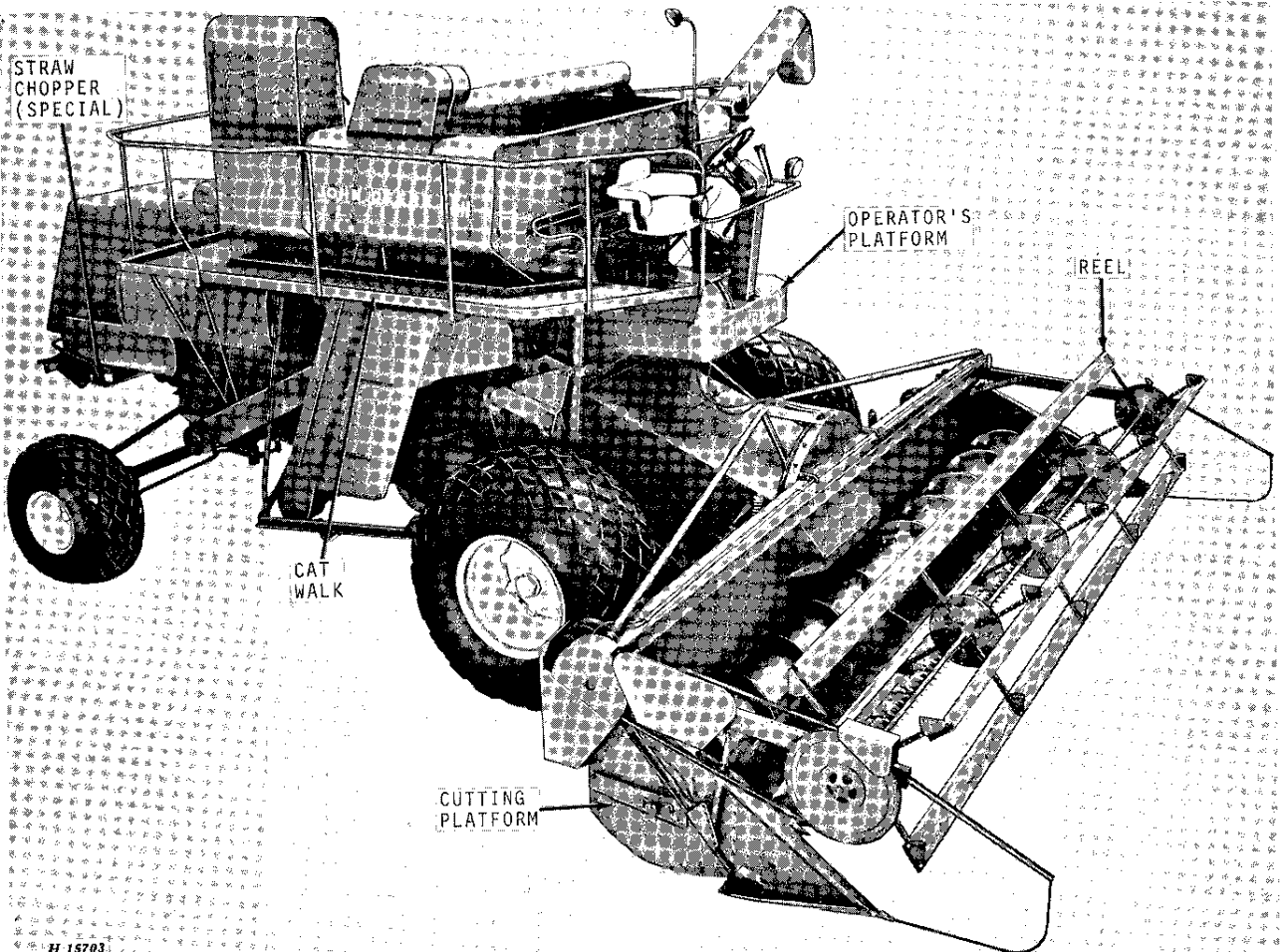

STRAW CHOPPER (SPECIAL)

OPERATOR'S PLATFORM

REEL

CAT WALK

CUTTING PLATFORM

H 15703

<https://www.ebooklibonline.com>

Hello dear friend!

Thank you very much for reading.

Enter the link into your browser.

The full manual is available for immediate download.

<https://www.ebooklibonline.com>

WHEEL TREAD DIMENSIONS	
Tire Size	Center-to-Center
23.1-26	112 inches
26.5-25	115-1/2 inches
18.4-16A	106 inches

CAPACITIES (APPROX.)

Fuel tank	40 U.S. gallons—diesel 60 U.S. gallons—gasoline
Cooling system	7 U.S. gallons
Engine crankcase	10 U.S. quarts
Transmission	14 U.S. pints
Final drives (2)	4-1/2 U.S. pints each
Hydraulic system reservoir	12 U.S. quarts
Automatic leveling system reservoir	18 U.S. quarts

GASOLINE ENGINE

Make and model of engine	John Deere HC303G
Bore	3.86 in.
Stroke	4.33 in.
Brake horse power	100*
Number of cylinders	6
Piston displacement	303 cu. in.
Maximum load speed	2500 rpm
Firing order	1-5-3-6-2-4
Crankcase	Cast integral with block
Type of lubrication	Force feed by gear pump
Valve arrangement	Valve in head
Valve clearance:	
Intake	.014-in.
Exhaust	.022-in.
Make of governor	John Deere
Make of carburetor	Marvel-Schebler
Air cleaner	Dry type
Spark Plug	Size 14 mm-gap .025-in.
Electrical system	12 volt
Cooling system	Water pressure
Type of fuel	Gasoline (regular)
Oil filter	Full flow

TIRE INFLATION CHART		
Tire Size	Ply Rating	
18.4-16A (Low profile)	6	10 lbs.
23.1-26 (Low profile)	10	18 lbs.
26.5-25 (Low profile)	12	16 lbs.

DIESEL ENGINE

Make and model of engine	John Deere HA303D
Bore	3.86 in.
Stroke	4.33 in.
Brake horse power	100*
Number of cylinders	6
Piston displacement	303 cu. in.
Maximum load speed	2500 rpm
Firing order	1-5-3-6-2-4
Crankcase	Cast integral with block
Type of lubrication	Force feed by gear pump
Valve arrangement	Valve in head
Valve clearance:	
Intake	.014-in.
Exhaust	.018-in.
Make of injection pump	Roosa-Master
Make of fuel injection nozzles	Roosa-Master
Air cleaner	Dry type
Electrical system	12 volt
Cooling system	Water pressure
Type of fuel	No. 1-D or No. 2-D Diesel fuel
Oil filter	Full flow

*Factory observed at 85°F. and 29.38 in. Hg. at 500 ft. above sea level.

4 Specifications

COMBINE DIMENSIONS—OVER-ALL

NOTE: Dimensions are for combine equipped with 23.1-26 front tires and 18.4-16A rear tires.

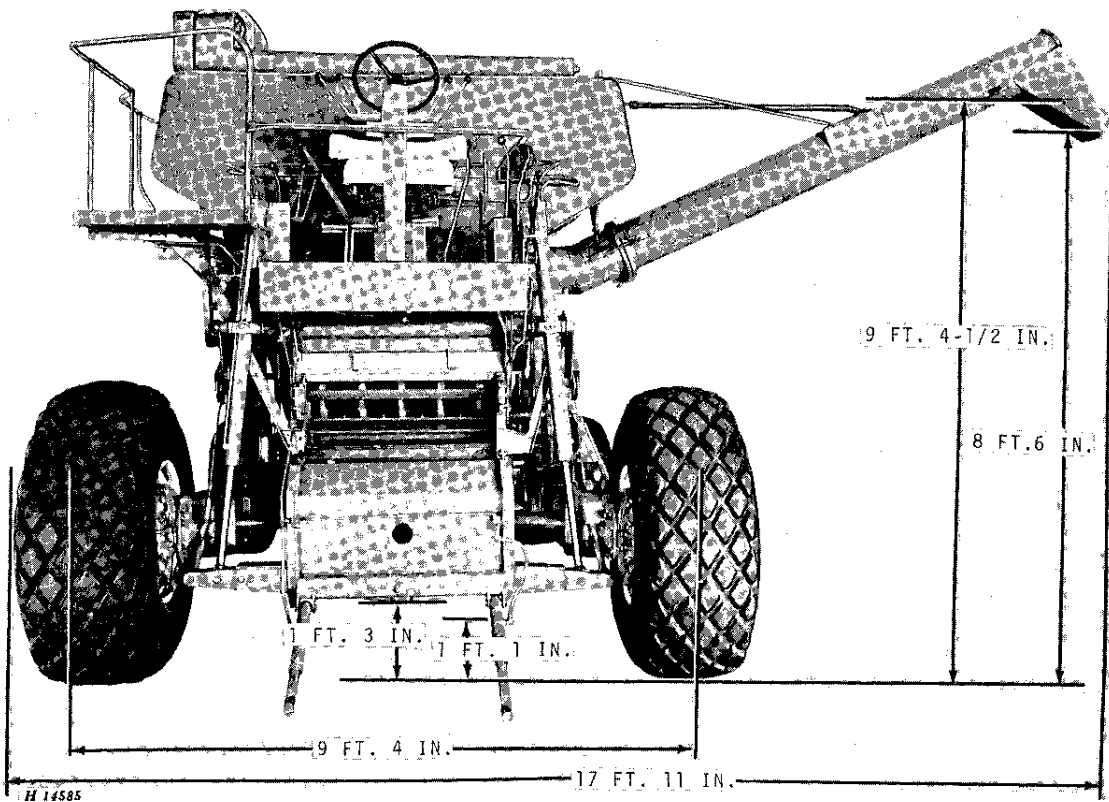
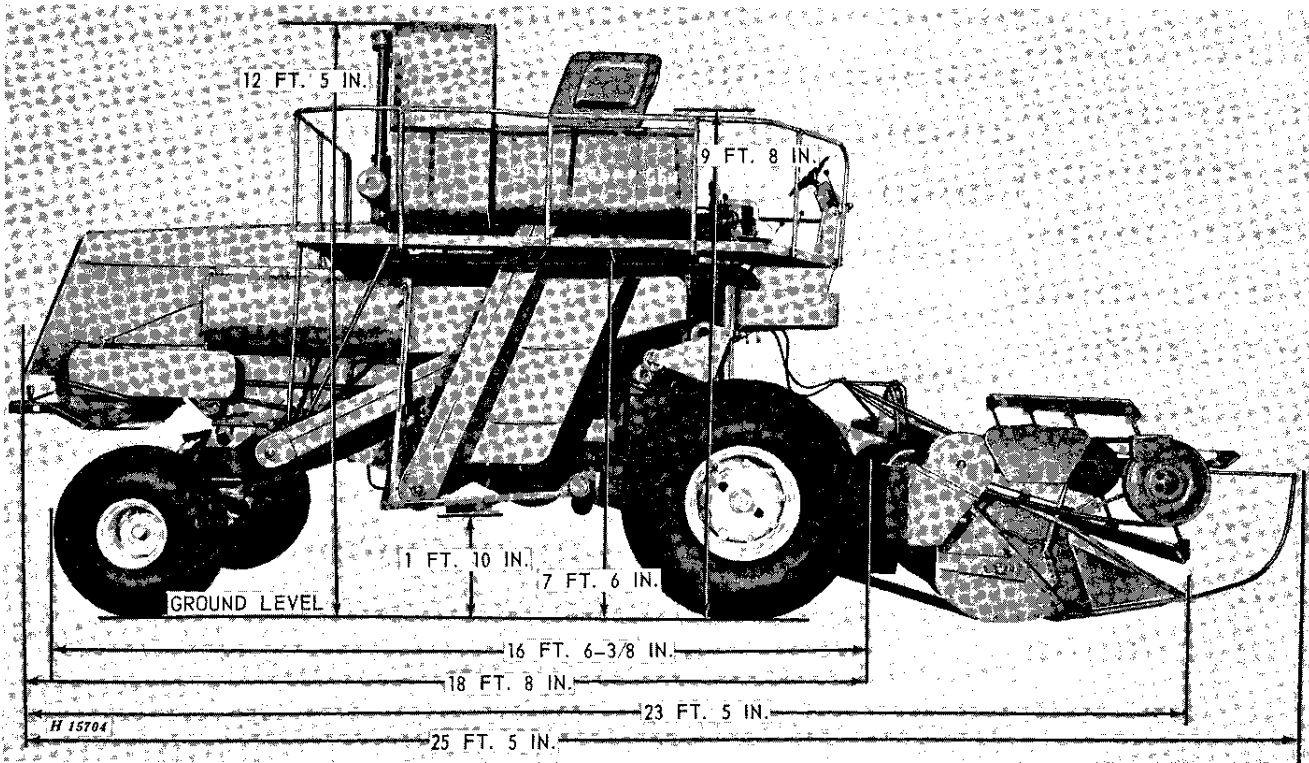



CONTROLS AND INSTRUMENTS

Before attempting to operate your new combine, become familiar with the location and purpose of its controls and instruments. Study these pages carefully, regardless of your previous combine experience.

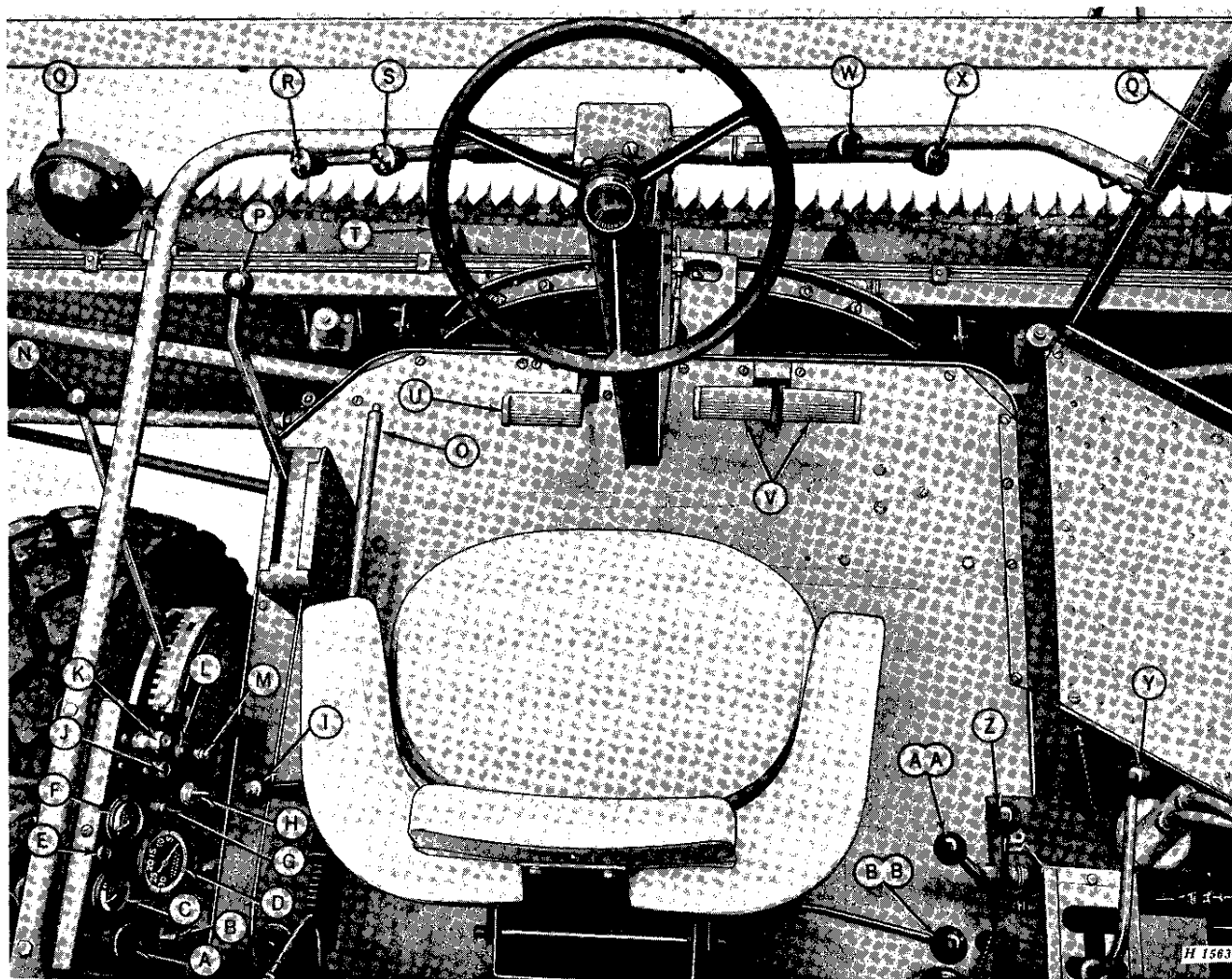

- A - Instrument Panel Light
- B - Light Switch
- C - Temperature Gauge
- D - Tachometer-Hour Meter
- E - Alternator Warning Light
- F - Oil Pressure Gauge
- G - Starter Button
- H - Key Switch
- I - Separator Throw-Out Lever
- J - Parking Brake Warning Light
- K - Cutting Platform Throw-Out Switch
- L - Leveling Limit Warning Light
- M - Automatic Leveling Control Cut-Out Switch
- N - Concave Front Adjusting Lever

- O - Parking Brake Lever
- P - Grain Tank Unloading Lever
- Q - Field Lights
- R - Reel Variable Speed Control Lever
- S - Reel Hydraulic Lift Control Lever
- T - Steering Wheel
- U - Clutch Pedal
- V - Brake Pedals
- W - Cutting Platform Height Control Lever
- X - Selective Ground Speed Control Lever
- Y - Transmission Gearshift Lever
- Z - Throttle Control Lever
- AA - Choke Control Lever—Gasoline Only
- BB - Manual Leveling Control Lever

H 15636

6 Controls and Instruments

The combine controls are located on the operator's platform within easy reach of the operator. Those controls whose purpose and function are obvious will not be explained.

TEMPERATURE GAUGE

This gauge indicates the coolant temperature in the cooling system. Normal operating temperature is 180° to 219° F. (indicated by white band on dial). If 219° F. or above (indicated by red band on dial), stop engine and determine cause.

ALTERNATOR WARNING LIGHT

This light indicates whether or not the alternator is charging. Should the light go on while the engine is running, alternator is not charging; stop engine and determine cause.

OIL PRESSURE GAUGE

This gauge indicates the pressure of engine lubricating oil. Oil pressure will vary slightly with engine wear, but with recommended oil, it should read normal at full governed speed (indicated by white band on dial). If oil pressure drops, (indicated by red band on dial) stop engine immediately and determine cause.

CUTTING PLATFORM THROW-OUT SWITCH

This switch operates the electromagnetic throw-out clutch which permits instant stopping of the cutting platform and feeder while the separator continues to run.

Push the switch down to disengage drive, then when the trouble has been taken care of, push switch down again to engage drive.

PARKING BRAKE WARNING LIGHT

When the parking brake is engaged, the warning light will flash on and off the instant the ignition is turned on. This is a precaution against moving the combine with the parking brake engaged.

LEVELING LIMIT WARNING LIGHT

The leveling limit warning light will flash on and off when the separator has reached the automatic leveling limit; beyond this point, the separator will start to lean and the operator should proceed only with the utmost caution.

AUTOMATIC LEVELING CONTROL CUT-OUT SWITCH

This switch enables the operator to disengage the automatic leveling control mechanism if so desired for various purposes such as transporting.

TACHOMETER-HOUR METER

The hour meter registers both the engine rpm in hundreds and hours of engine operation.

The tachometer tells the operator whether or not he is operating at full governed speed.

The hour meter allows the operator to make periodic services and adjustments at the proper time.

SEPARATOR THROW-OUT LEVER

This lever is disengaged in the rearward position. To engage, push lever forward.

CONCAVE FRONT ADJUSTING LEVER

Move lever forward to open front of concave; move lever rearward to close front of concave.

GRAIN TANK UNLOADING AUGER LEVER

Pull the lever rearward to engage the auger. To disengage auger, move the lever forward. Grain tank unloading drive and separator drive are independent. If the engine is running, the separator can be stopped without affecting unloading of the grain tank.

PARKING BRAKE LEVER

The parking brake lever is used to lock the wheel brakes so the combine cannot move if left unattended. To engage, pull lever rearward. To disengage, depress button and move lever forward.

Never attempt to move combine with parking brake lever engaged.

REEL VARIABLE SPEED CONTROL LEVER

To increase reel speed, move the lever forward. To decrease the reel speed, move lever rearward. The lever automatically returns to neutral when released.

REEL HYDRAULIC LIFT CONTROL LEVER

To raise reel, move lever rearward. To lower the reel, move lever forward. The lever automatically returns to neutral when released.

CUTTING PLATFORM HEIGHT CONTROL LEVER

This lever hydraulically controls the height of the cutting platform. Move the lever forward to lower cutting platform; pull it rearward to raise cutting platform. When released, the lever automatically returns to neutral position and the cutting platform remains at selected position. As a safety measure, cutting platform height cannot be changed unless the engine is running.

SELECTIVE GROUND SPEED CONTROL LEVER

To increase ground travel speed within a selected transmission range, move lever forward. It will automatically return to neutral position when released and speed will remain as selected. Separator speed remains constant.

TRANSMISSION GEARSHIFT LEVER

The combine has four forward speed ranges and one reverse range. Position the gearshift lever for different transmission speed ranges according to the diagram.

CAUTION: Be certain the gear shift lever is in neutral position and clutch pedal is fully depressed before starting engine.

THROTTLE CONTROL LEVER

Move lever one quarter forward from rear to start engine. **NOTE:** On combines with diesel engine, it is necessary to lift plunger on the throttle lever before the lever can be moved. Move lever all the way rearward for slow idle; move lever all the way forward for normal operation.

CHOKE CONTROL LEVER

Move lever all the way forward when starting engine. After engine has started, and for normal operation, move lever all the way rearward.

MANUAL LEVELING CONTROL LEVER

If the automatic leveling mechanism should fail to function, or if the operator desires to tilt the separator while on level land, the leveling mechanism can be controlled by means of the manual control lever. Move lever to right for right-hand tilt and to left for left-hand tilt.

OPERATOR'S SEAT

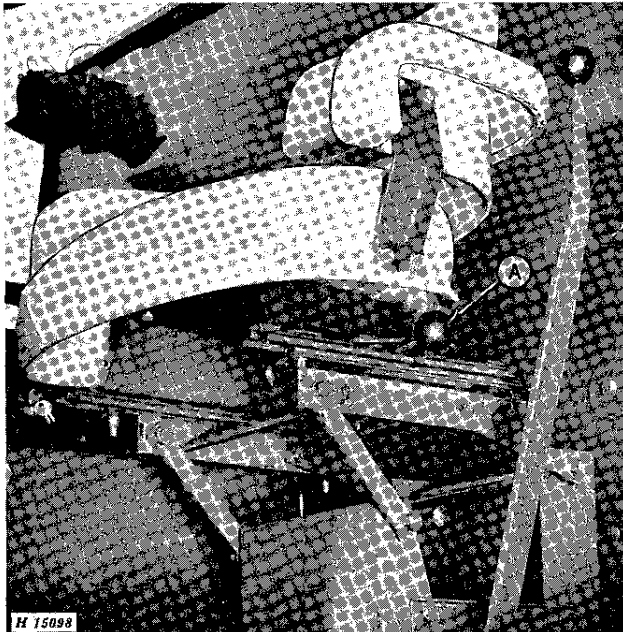

Seat in Sitting Position

The lever on the seat permits the operator to move the seat forward or rearward to accommodate his individual height and allow greater accessibility to all controls. If the operator wishes to stand, the seat can be positioned out of the way to allow ample leg space.

Use only warm water and mild soap to clean the seat cushions. NEVER USE SOLVENTS.

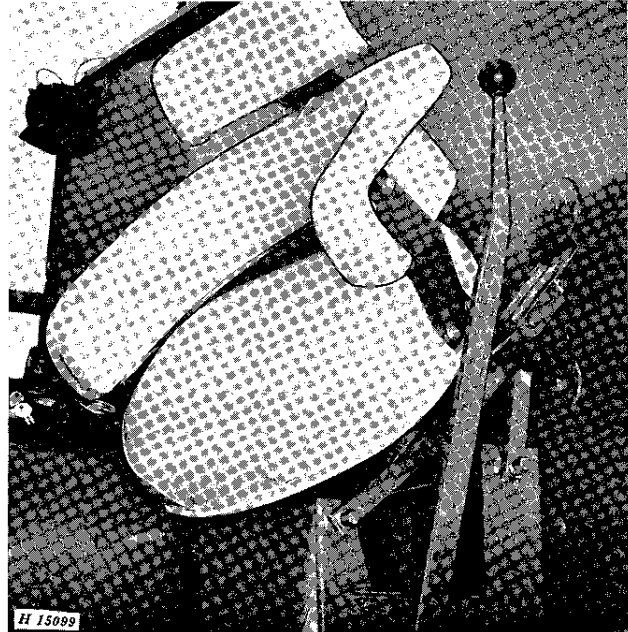

Seat in Standing Position

POSITIONING THE SEAT FORWARD OR REARWARD

While sitting in the seat, push lever "A" forward as far as possible and by using your weight, adjust seat to desired position and then release lever "A."

POSITIONING THE SEAT FOR STANDING

To move the seat up and back, stand up and apply pressure to the front of the seat with the back of your legs. The seat will move to the up and back position to allow standing room.

To return the seat to the sitting position, move the seat forward by pulling on the front of the seat with your hand.



OPERATION

FUNDAMENTALS OF COMBINE HARVESTING

The most important factor in harvesting, is for the operator to have a thorough understanding of the fundamentals of combine operation.

Be sure crop is in condition to thresh—moisture content not too high—straw not too green.

In making the first round of the field, keep the combine forward speed as slow as possible to reduce the volume of material entering the combine. Always run the engine at full throttle to keep the combine mechanism up to full speed, thus guarding against slugging and clogging. Use the selective ground speed drive to obtain slower speed or shift to a lower gear if necessary—but do not throttle down the engine.

Select a ground speed that will not overload the combine.

Engine should be in good condition—governor should be properly set and responsive enough to accelerate quickly if an overload occurs.

Keep the cylinder speed as low as possible and concave clearance as high as possible to remove the maximum amount of grain from head without breaking up the straw excessively. Maintain correct beater speed to guard against wrapping of straw on beater.

Cut the crop as high as possible without excessive loss of low grain heads. If the crop is down and tangled, it may be desirable to use lifting guards. Slow travel speed is imperative.

Adjust the reel position and speed for even feeding.

Regulate adjustable chaffer openings to pass the grain or seed to the lower sieve before it has passed over two-thirds the length of chaffer without admitting too much coarse material.

Close adjustable sieve as far as possible without carrying clean grain into the tailings auger.

If material loads up on front of chaffer, adjust upper windboard to throw air blast to front of shoe.

Use as much air as possible without blowing over clean seed. If the grain or seed is unusually light, it may be necessary to reduce the volume of air. In heavy seeds, increase air volume.

Keep amount of tailings as low as possible.

FUNDAMENTALS OF AUTOMATIC LEVELING

The automatic leveling control switch actuates the leveling mechanism, allowing the separator to be held level while the wheels conform to the contour of the hill.

When the combine has reached the limit of its automatic leveling capacity, approximately 42 per cent, the limit switch cuts in an electrical circuit to a flasher light on the instrument panel. The light will continue to flash on and off as long as the arm on the axle pivot contacts the limit switch plunger. This indicates to the operator the limit of leveling has been reached, and beyond this point, the separator will start to lean.

When the ignition switch is turned off, the automatic leveling will not function.

OPERATING SUGGESTIONS

Don't start combining until the crop is ripe.

Unless crop drying equipment is available, a crop should not be combined until it is dead ripe. If the threshed grain feels damp or is easily dented with the fingernail, the moisture content is usually too high for safe storage.

Grain crops containing 14 per cent moisture or less are usually considered dry enough for safe storage. A John Deere Moisture Meter for checking moisture content of grain and a portable Grain Dryer can be purchased from your John Deere dealer, or arrangements can usually be made at the local grain elevator for necessary moisture tests and drying if necessary.

OPERATION IN WEEDY CONDITIONS

Combining in fields where weeds are numerous is particularly troublesome as they tend to gum up the sieves. Also, the moisture in the seeds is imparted to the grain.

Cut the crop as high as possible to avoid weeds and undergrowth.

Check to see that the cylinder is operating at proper speed.

Use as much air blast on the shoe as possible without blowing over grain.

Lower rear end of chaffer.

SELECTING PROPER GROUND SPEED

The ground speed of the combine can be very closely controlled by using the selective ground speed control in conjunction with different transmission speeds. The chart on page 17 shows the speeds that can be obtained in each transmission range. Select the best transmission range; then, with the selective ground speed control adjust the ground speed to exactly meet field conditions.

Excessive travel speed is one of the greatest causes of trouble in combining. Traveling at too high a ground speed causes overloading, resulting in a loss of grain.

Also, traveling at an excessively high speed over rough ground causes extra wear and damage to parts, not incurred when the combine is operated at a more reasonable speed.

By rounding the corners in the field, you can maintain more uniform speed when turning.

When stopping, wait until material in the combine is cleaned out before disengaging separator throw-out lever.

KEEP STEADY, SMOOTH ENGINE SPEED

Any fluctuation in engine speed is reflected in the speed of the separator. Uneven speed results in loss of grain, inferior threshing and, in extreme cases, complete plugging of the combine. Take every precaution to maintain the correct uniform speed.

COMBINE AND ENGINE BREAK-IN

Follow the lubrication instructions and charts closely. See pages 22 to 43.

Check coolant level in radiator. Add proper coolant as necessary. Do not use water containing alkali. *If combine is being operated at temperatures below 32° F., refer to "Cold weather operations," page 12.*

To promote good ring seating and to prevent cylinder wall glazing, put the engine to work as soon as possible. Do not overload. Second gear will give the best break-in load during early operation. If prolonged transport periods are required, use third gear. This will keep torque level up and induce ring seating.

AFTER 5 HOURS

Lubricate the straw walker bearing blocks with SAE multipurpose grease every 5 hours of operation for the first three days; every 150 hours of operation thereafter.

AFTER 20 HOURS

After the first 20 hours of operation, drain oil from hydraulic system reservoir. Remove the oil filter and clean in diesel fuel. Replace the oil filter and fill the reservoir with service MS engine oil as shown in the chart on page 21. Thereafter, drain and replace oil and oil filter element every 500 hours of operation.

AFTER 50 HOURS

After the first 50 hours of operation, drain oil from transmission and final drives and fill with SCL multipurpose-type SAE 90 gear oil. Thereafter, drain and refill every 500 hours of operation or every season (whichever comes first).

AFTER 100 HOURS

Gasoline Engines

During break-in, if oil consumption warrants, add service MS SAE 10W or Mil-2104B engine oil.

After the first 100 hours of operation, drain oil from crankcase, replace oil filter, and fill crankcase to proper level with service MS oil of the proper viscosity as specified in lubricants chart on page 21.

Diesel Engines

During break-in, if oil consumption warrants, add service DM SAE 10W-30 engine oil.

When sulphur content of the diesel fuel exceeds 0.5% during the first 100 hours of operation, drain oil from crankcase, replace oil filter and fill crankcase to proper level with service DS oil of the property viscosity as specified in lubricants chart on page 21.

After breaking-in both gasoline and diesel engines, drain and replace crankcase and oil filter every 100 hours of operation or every season whichever occurs first, using the correct oil as specified in lubricants chart on page 21.

BEFORE-OPERATION CHECKS AND ADJUSTMENTS

Careful inspection and service of the combine before starting work each day will prevent needless delays and breakdown in the field. Make the following checks and adjustments:

Check all V-belt drives carefully for proper alignment and tension. Keep belts tight enough to prevent slippage. Belts can be ruined very quickly if allowed to slip in the grooves of a sheave for any length of time. Excessive heating of a sheave is a sign of belt slippage. New belts will stretch slightly after the first run-off. Check tension frequently.

Open the clean-out doors in the bottom of the clean grain and tailings elevators and check tension of elevator chains. Check the chain tension every day of operation.

Be certain all shafts turn freely.

See that no bolts are loose or no cotter pins are missing.

Fill fuel tank with proper grade of fuel. See fuels and lubricants section.

Check the radiator and if necessary add coolant slowly until the level is approximately 1-inch below the bottom of the filler neck.

Lubricate the combine completely. Service air cleaner, and check oil level of hydraulic units, transmission, and final drives. See Lubrication section.

STARTING THE ENGINE

Before starting engine, the following items should be checked:

1. Cutting platform throw-out switch disengaged.
2. Separator throw-out lever disengaged.
3. Grain tank unloading lever disengaged.
4. Gearshift lever in neutral.
5. Clutch pedal fully depressed.

If starting in cold weather, see "Cold weather operation," page 12.

GASOLINE ENGINE

If engine has not been operated for a period of time, or the fuel tank has run dry, prime fuel pump lever up or down to force gasoline into carburetor.

NOTE: After priming fuel pump, be sure the priming lever is in the down position. If the priming lever is left in the up position, the fuel pump is inoperative.

Move throttle lever one-quarter open. Move choke lever all the way forward, depress clutch pedal, turn key to "on" and press starter button. After engine starts, release starter button and push choke control rearward. Check oil pressure gauge to make certain it is registering pressure; if not, stop engine and determine cause.

Release clutch, warm engine and transmission for five minutes at fast idle—no load. Do not operate combine during warm up.

DIESEL ENGINE

If the engine has not been operated for a long period of time, or if the fuel tank has run dry, it is necessary to bleed the entire fuel system to remove air bubbles. See page 93 for bleeding procedure.

CAUTION: Never let the fuel tank run dry.

Move throttle to one-quarter open, depress clutch pedal, turn key to "ON" and press starter button.

After engine starts, release starter button and check oil pressure gauge to make certain it is registering pressure; if not, stop and determine cause.

Release clutch, and let engine and transmission warm up for five minutes at fast idle—no load. Do not operate combine during warm up.

STOPPING THE ENGINE

GASOLINE ENGINE

Set throttle at medium idle speed and allow engine to run at this speed for a few minutes before stopping.

DIESEL ENGINE

Set engine at medium idle speed and allow engine to run at this speed until temperature gauge drops well into white range on dial. Move throttle to rear and turn off key.

CAUTION: Do not attempt to stop engine by turning off fuel supply at tank. Doing so will cause injection pump to run dry and damage internal parts.

STARTING THE COMBINE

CAUTION: Make certain no one is standing near enough to the combine to touch any moving parts. Warn everyone to stand clear.

When engine is properly warmed, move separator throw-out lever forward to engage the separator. Push throttle lever all the way forward.

Check the speed of beater behind the cylinder with a speed indicator. Beater should operate at 680 to 685 rpm with separator empty and not under load. If beater speed is not correct, adjust governor setting.

Test operation of hydraulic control for adjusting cutting platform height.

Test operation of grain tank unloading auger.

Test operation of hydraulic selective ground speed control.

Check brakes to see if they are in proper working order.

Test operation of hydraulic leveling system with the manual leveling control lever.

Inspect entire combine again, making certain all units are working properly.

Disengage separator, then close doors at bottom of elevators.

TRANSPORTING

When transporting, drive combine under its own power or load it on a truck. Combine may be towed with caution.

This combine is designed for easy and safe transporting. The width of the combine can be reduced by folding the unloading auger back along the separator and removing the cutting platform. The radiator screen can be hinged down to reduce the height.

Over-all dimensions are given on page 4.

If the cutting platform is removed, the hydraulic cylinders must be wired or supported by support chains (special attachment) no closer to separator than 14 inches. Damage may result to hoses if carried too close.

Reduce the spread of noxious weed seeds by cleaning out combine thoroughly before leaving one field and going to the next.

When through cutting in a field, sweep trash and straw from outside of combine, open doors at bottom of elevators and run combine until all straw, trash, and grain are removed from inside of combine before moving to the next field.

CAUTION: When driving the combine on a road or highway at night or during the day, use accessory lights and devices for adequate warning to the operators of other vehicles. In this regard check local governmental regulations.

COLD WEATHER OPERATION

HYDRAULIC UNIT AND CRANKCASE

Use the grade of oil recommended in the lubrication section. Lubricants of the right viscosity are necessary for proper protection.

TRANSMISSION AND FINAL DRIVES

Use only SCL Multipurpose-type SAE 90 gear oil for year-round use; however, if oil is too heavy, thin with SAE 10W oil.

FUEL SYSTEM

Use winter-grade fuel. Fill the fuel tank at the end of the day's run to prevent moisture from condensing in the fuel tank.

COOLING SYSTEM

Drain, flush and fill cooling system with a recognized brand of radiator sealer and anti-freeze solution. Use a permanent-type (ethylene glycol) antifreeze solution containing rust inhibitors. This type of antifreeze is resistant to evaporation when heated.

Also, see cold weather operation, page 101.

LEVELING SYSTEM

Fill leveling system with 50% water and 50% permanent-type (ethylene glycol) antifreeze solution.

BATTERIES

When the temperature drops below freezing, take precautions to avoid damage to the battery cells. A badly discharged battery freezes more quickly than one that is well charged. For example, a battery with a specific gravity reading of 1.175 (discharged) will freeze at 4° F., and a battery with specific gravity reading 1.300 (fully charged) will not freeze until the temperature reaches -65° F.

In freezing weather, do not add water to the batteries unless engine is going to be run. Water will readily freeze as it will not mix with the electrolyte until the alternator passes a charging current through the batteries.

CAUTION: If booster batteries are required see instructions on page 88. Also, see BATTERIES; page 87.

COLD WEATHER STARTING AID

Diesel engines are equipped with an ether starting fluid adapter which is used to inject atomized fluid into the engine air intake system. Normally ether is used for starting at temperatures below 32° F. Pressurized cans of starting fluid are available from your John Deere dealer.

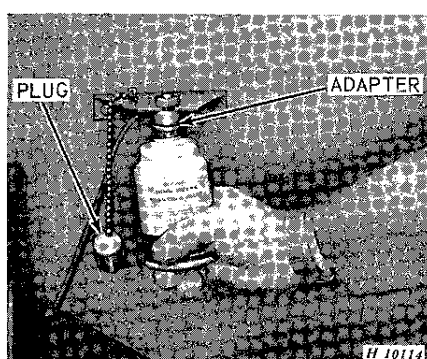

To use the starting fluid, remove the safety cap and plastic spray button from the can. Remove the cap from the adapter and position the can under the adapter.

To inject starting fluid, push up on the can.

CAUTION: To avoid damage, turn engine with starter one or two revolutions before injecting starting fluid. Inject starting fluid only while the engine is turning.

Relax pressure on the can between "shots" of starting fluid. Stop injecting fluid after the engine starts. If the engine begins to die during the first few minutes of operation, inject another "shot" of fluid. When the engine is operating satisfactorily, remove the can from the adapter and replace the safety cap on the can.

Be certain to install the cap on the adapter when it is not in use. This will prevent dust from being drawn into the engine.

CAUTION: Ether starting fluid is highly flammable.

Store starting fluid cans where they will not be subject to extreme cold or warm temperatures. For best results, store fluid at room temperature.

END OF SEASON SERVICE

It is recommended that AR41785 kit be used when preparing combine and engine for storage. This includes rust inhibitor, tape, and plastic bags required in the following steps.

ENGINE

1. Wash the outside of engine thoroughly. Use diesel fuel and a stiff brush.
2. Clean inside of air cleaner, remove dirt from filter, and install filter in air cleaner.
3. With engine warm, drain crankcase. Replace filter and fill crankcase with new oil of proper weight and quality. See page 21.
4. Drain, flush, and refill cooling system as follows:
 - a. If freezing weather is anticipated, fill system with antifreeze to lower temperature expected per chart on page 101.
 - b. If warm weather is anticipated, fill with clean, soft water and add T19566T-- Summer Engine Coolant Conditioner.

14 Operation

END OF SEASON SERVICE—Continued

5. Drain gasoline or diesel fuel tank. On gasoline engine only, drain sediment bowl and drain carburetor by operating engine at fast idle until it stops. Add 1/4 oz. of rust inhibitor for each gallon of fuel tank capacity. See page 3.

6. Add 1 oz. of rust inhibitor for each quart of crankcase capacity. See page 3.

7. Place rust inhibitor in intake system.

a. Gasoline Engine: Pour 1/2 oz. rust inhibitor in each spark plug opening. Replace spark plugs.

b. Diesel Engine: Remove intake pipe to manifold hose and pour 1/2 oz. rust inhibitor in each cylinder. Replace hose. Turn engine over slowly two revolutions. Do not allow to fire.

8. Remove battery or batteries and store in a cool, dry place not subject to freezing. Check batteries in storage every 30 days and charge them if necessary.

9. Remove radiator screen and duct and use air or water under pressure to clean out any dust or dirt accumulated in radiator core.

10. Use plastic bag and/or tape to seal the following openings:

Rocker arm cover vent tube.

Pre-cleaner, air intake pipe, or manifold. Exhaust manifold or muffler. Cover drain hole in muffler.

Fuel tank cap.

Transmission breather cap.

Hydraulic oil reservoir breather.

COMBINE

1. If possible, shelter the combine in a dry place.

2. Clean the combine thoroughly inside and out. Chaff and dirt will draw moisture and rust the steel.

3. Loosen belts, wipe clean with good non-flammable solvent. Line grooves of sheaves with clean paper to prevent belts from contacting metal surfaces.

4. Clean out augers and elevators. Leave doors open at bottom of elevators.

5. Clean out bottom of grain tank and unloading auger. Open clean-out door.

6. Clean the chaffer and sieve.

7. Grease feeder house conveyor bottom so it will not rust.

8. Drain transmission, final drives and hydraulic systems. Refill according to lubrication instructions on page 43.

9. Add rust inhibitor to transmission final drives and hydraulic systems.

1 oz. in hydraulic unit reservoir

2 oz. in transmission

1 oz. in each final drive

10. Lubricate combine completely. See Lubrication Charts. Grease the threads on bolts used for adjustments. Apply a coating of grease to slip clutch jaws.

11. Paint all parts from which paint has worn.

12. Support cutting platform with blocks to level it.

13. Block up combine, taking load off tires. Do not deflate tires. If combine is stored outside, remove wheels and tires and store in a cool, dark, dry place.

14. Block clutch pedal in disengaged position to prevent damage to clutch plates during storage.

15. Release spring tension on slip clutches.

16. On the electromagnetic throw-out clutch for the cutting platform, place a few drops of SAE 30 oil on the four studs for the face plate.

17. List the repairs that will be needed before the next season and order them early. Your John Deere dealer can give better service during the off season, and when parts are received, they can be installed in your spare time—no delay at harvest time.

BEGINNING OF THE SEASON SERVICE

Before the next harvest season, make the following checks and adjustments to avoid costly breakdown during the harvest season.

ENGINE

1. Remove rocker arm cover and inspect for freedom of valves by turning engine over and watching valves to see that they open and close freely.

If valves seem sticky or excessive rust or moisture deposits are present in the rocker arm compartment, squirt upper cylinder lubricant on valve stems to free up. Also inspect push rods to see that they are in their socket in the rocker arm and not bent.

2. Adjust valve tappets. (Page 99).

3. Clean inside of air cleaner and install new filter element.

4. Remove sealing tape or plastic bags from all covered openings. Check list on page 14.

5. Check engine, transmission, final drives and hydraulic system oil levels with dipsticks. If low, check for leaks and add oil as required.

6. Remove radiator cap and check coolant level. If low, check for loose connections or leaks.

7. Service cooling system as required.

a. Warm weather operation: Drain anti-freeze, if used, and fill cooling system with clean soft water. Add required amount of Summer Engine Coolant Conditioner, T19566T.

b. Cold weather operation: Be certain sufficient antifreeze is used to provide for coldest anticipated temperature. (See chart on page 101).

8. Fill the fuel tank with proper fuel. Page 20.

9. Install batteries. Check electrolyte and battery charge.

On Gasoline Engine Only:

1. Clean and adjust spark plugs. Replace worn or oil soaked wiring. Check distributor points for wear and corrosion. Replace if necessary.

2. Clean all fuel lines and fuel filters. Blow out carburetor jets with air—never use a wire.

On Diesel Engine Only:

1. Bleed entire fuel system before starting engine. See page 93 for bleeding procedure.

COMBINE

1. Replace wheels if they were removed and remove blocking. Check tire inflation, page 80.

2. Clean the combine thoroughly inside and out.

3. Adjust belts, making sure they have the proper tension. Remove paper from sheave groove.

4. Adjust chains to proper tension. Be sure to check chains in clean grain and tailings elevators.

5. Clean slip clutches. Be sure to put grease in bore of slip clutches after cleaning. Adjust spring tension on slip clutches.

6. Close elevator doors and close grain tank unloading auger clean-out door.

7. Lubricate combine completely, following Lubrication Charts; then run combine in half-speed for several minutes. Check bearings for over-heating or excessive looseness. Be sure slip clutches operate freely.

8. Go over complete combine and see that all bolts are tight and cotter pins are in place.

9. Review your operator's manual.



Suggest:

If the above button click is invalid.

Please download this document

first, and then click the above link

to download the complete manual.

Thank you so much for reading



OPERATING SPEEDS AND SETTINGS

ENGINE

Description	Speed	Page
Gasoline*	2500 rpm	95
Diesel*	2500 rpm	94

*Full Load (Add 150 rpm to Above Speeds for No Load-Fast Idle)

CUTTING PLATFORM AND FEEDER HOUSE UNITS

Description	With regular 50-Tooth Sprocket on Left-Hand End of Feeder Shaft	With Special 56-Tooth Sprocket on Left-Hand End of Feeder Shaft	Page
Reel	19.1-50.5 rpm	17.0-45.1 rpm	47
Knife	403 strokes per minute	359 strokes per minute	49
Knife and Platform Countershaft	403 rpm	359 rpm	---
Platform Auger			53
56-tooth Sprocket (Regular)	144 rpm	128 rpm	
42-tooth Sprocket (Special)	192 rpm	171 rpm	
Feeder Beater in Front of Feeder House	161 rpm	141 rpm	54
Feeder House Conveyor Drive Shaft	231 rpm	206 rpm	---
Feeder House Conveyor Chain	318 feet per minute	284 feet per minute	54

<https://www.ebooklibonline.com>

Hello dear friend!

Thank you very much for reading.

Enter the link into your browser.

The full manual is available for immediate download.

<https://www.ebooklibonline.com>