

65 PULL-TYPE COMBINES



JOHN DEERE

OPERATORS MANUAL 65 PULL-TYPE COMBINES

OMH90630162 (01JAN62) English

OMH90630162 (01JAN62)

LITHO IN THE U.S.A.
ENGLISH



TO THE PURCHASER

The combine you have just purchased was designed and manufactured to the traditionally high quality standards of all John Deere Farm Equipment. Your combine has been thoroughly inspected and tested, not only at the factory, but at your dealer's by a trained John Deere Serviceman. We are confident that you will receive years of dependable, economical service from your John Deere Combine.

If you should find that you require information not covered in this manual, consult your John Deere dealer. He will be glad to answer any questions that may arise regarding the operation and handling of the combine. He has specialized mechanics who are kept informed on the best methods of John Deere Combine servicing, and can give you prompt know-how service in the field or in his shop.

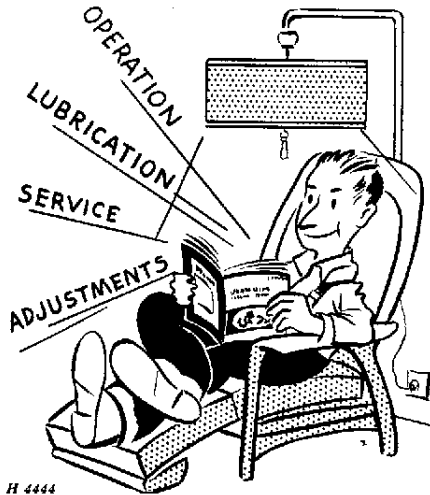

Study This Manual Carefully, Keep It Handy, In A Safe Place, For Future Reference.

LOCATION REFERENCE

"Right-hand" and "left-hand" sides are determined by facing in the direction the combine will travel when in use.

"Clockwise" refers to parts turning to the right like the hands of a clock. "Counter-clockwise" refers to parts turning to the left.

ENGINE REFERENCE ONLY

Timing gear end of the engine is referred to as the "front"; flywheel end as the "rear."

KEEP YOUR COMBINE A JOHN DEERE COMBINE

Genuine John Deere Parts fit properly and insure satisfactory service because they are made from the original patterns and from the same materials as used in new machines. Should your combine require replacement parts, go to your John Deere dealer where you can obtain Genuine John Deere Parts—accept no substitutes.

SERIAL NUMBERS

Your combine, cutting platform, and engine have serial numbers.

When ordering parts, always bring with you the model and serial numbers as given on the serial number plates. By doing so, you will assist your John Deere dealer in giving you prompt, efficient service.

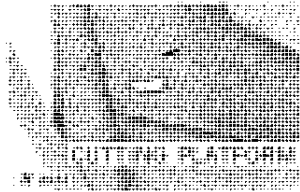
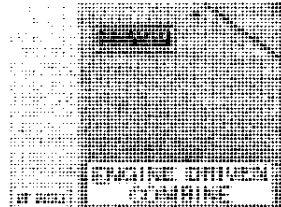

Record the serial numbers in the spaces provided on this page.

The engine-driven combine serial number is on a plate located on the support bracket at the rear end of the fuel tank.

The PTO-driven combine serial number is on a plate located on the grain tank unloading auger jackshaft left-hand support bracket.

The engine serial number is on a plate located on top of the flywheel housing.

The cutting platform serial number is on a plate located on the outside of the right-hand platform divider.

Combine Serial No. _____

Engine Serial No. _____

Cutting Platform Serial No. _____

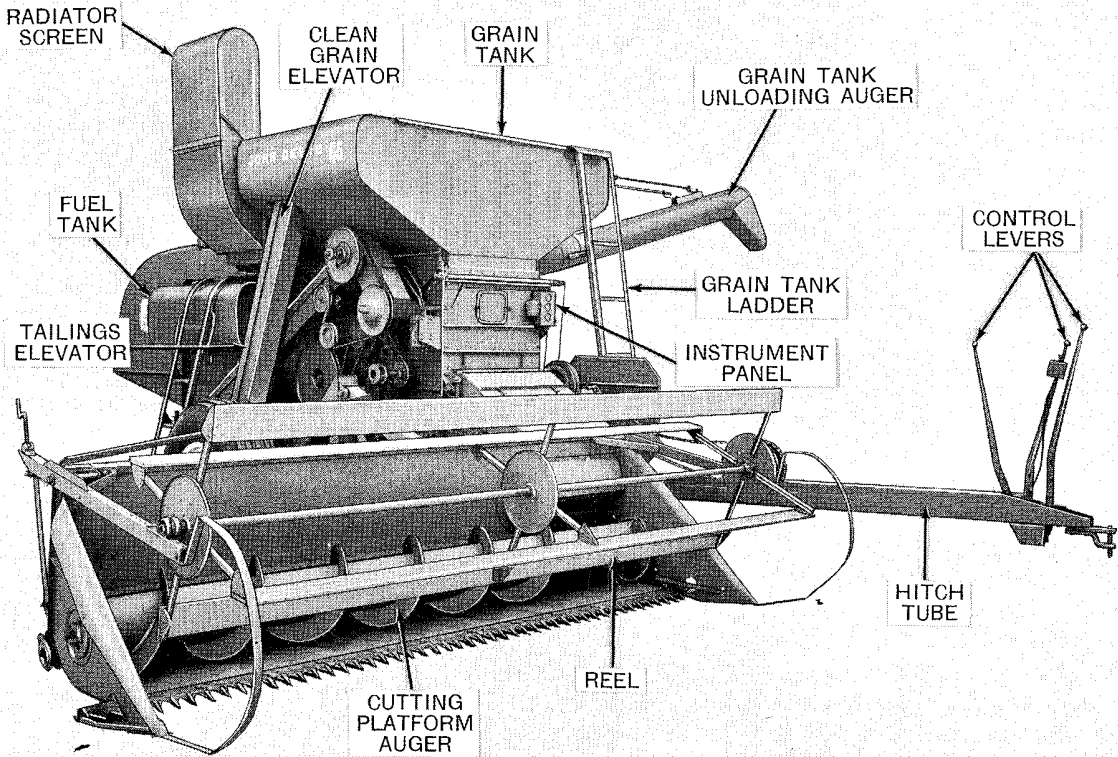

H 2526

Right-Hand Front View—John Deere 65 Grain Tank Combine—Engine-Driven

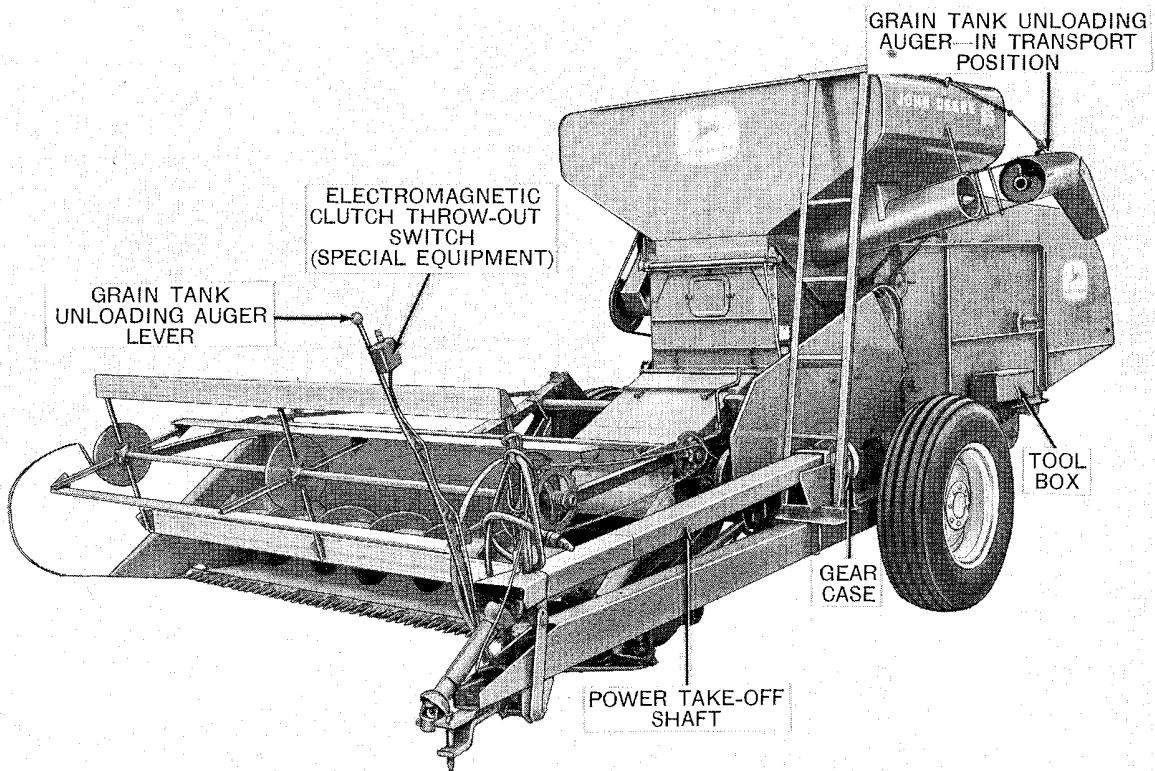

H 2527

Left-Hand Front View—John Deere 65 Grain Tank Combine—PTO-Driven

<https://www.ebooklibonline.com>

Hello dear friend!

Thank you very much for reading.

Enter the link into your browser.

The full manual is available for immediate download.

<https://www.ebooklibonline.com>

TABLE OF CONTENTS

	<i>Page</i>		<i>Page</i>
GENERAL VIEWS	1	Feeder Conveyor.....	42
SPECIFICATIONS	3-6	Cutting Platform Leveling Adjustment...	42
LUBRICATION	7-15	Belt Pickup.....	43
OPERATION	16-33	Cylinder and Concave Grate.....	44
Combine Controls.....	16	Beater Behind the Cylinder.....	54
Adjustable Parking Stand.....	17	Grain Conveyor.....	55
Hooking Up to Tractor.....	18	Feed Rolls Attachment.....	57
Breaking in the New Combine.....	20	Cleaning Fan.....	58
Engine Break-In.....	20	Chaffer and Sieve.....	61
Before Operation Checks and Adjust- ments.....	20	Shoe Pitman.....	65
Starting the Engine.....	20	Clean Grain and Tailings Elevators.....	66
Stopping the Engine.....	21	Straw Walkers.....	68
Starting the Combine.....	21	Straw Spreader.....	70
Selecting Proper Ground Speed.....	21	Straw Chopper.....	71
Cutting Platform Height.....	21	Grain Tank Extension.....	72
Speed of Various Units.....	22	ScourKleen.....	72
Basic Settings Made at the Factory.....	23	Grain Tank Unloading Auger.....	73
Fundamentals of Combine Harvesting.....	24	Separator Drive Tightener Pulley.....	75
Operating Suggestions.....	24	Electromagnetic Throw-Out Clutch.....	77
Slip Clutches.....	23, 34	Hydraulic System.....	78
Transporting.....	26	Care of Rubber Tires.....	78
Cold Weather Operation.....	27	Care of Chains and V-Belts.....	79
Suggested Settings for Combining Various Crops.....	28	Service Chart.....	81
Safety Suggestions.....	31	ENGINE SERVICE	90-104
Care When the Season Is Over.....	32	Fuel System.....	90
Care at the Beginning of the Next Season	33	Carburetor.....	91
ADJUSTMENTS AND SERVICE	34-89	Governor.....	91
Slip Clutches.....	34	Wiring Diagram.....	93
Inspection Doors and Ports.....	34	Ignition System.....	94
Reel.....	35	Starting System.....	96
Cutter Bar.....	38	Cooling System.....	99
Cutting Platform Auger.....	40	Valve Tappet Adjustment.....	101
Cutting Platform Auger Stripper.....	41	Engine Removal.....	101
		Special Equipment.....	102
		Service Chart.....	103
		ALPHABETICAL INDEX	105-108

SPECIFICATIONS

COMBINE

<p>Cutter Bar Width of Cut. 12 Ft. Length of Cutter Bar. 11 Ft. 6 In. Type of Knife Sections... Heavy-Duty Over-Serrated</p> <p>Reel Drive..... Chain No. of Slats.. 4 Regular; 3, 6, or 8 Special Dia. of Reel. 32 In. or 40 In. Speed Range. 28.1 rpm to 36.1 rpm</p> <p>Cutting Platform Type of Feed. Auger Range of Cut- ting Height. 2 In. to 30 In. Height Con- trol..... 2 Hydraulic Cyl- inders</p> <p>Cutting Platform Auger Diameter..... 18 In. Dia. of Auger Tube..... 10 In. Type of Auger Fingers... Round Retract- ing</p> <p>Cylinder Type..... Rasp-Bar or Spike-Tooth Width..... 30 In. Diameter.... 22 In. Number of Bars..... 8 Rasp-Bars or 10 Spike-Tooth Bars (5 Bars with 15 Teeth and 5 Bars with 14 Teeth) Drive..... Roller Chain Speed Range. 196 rpm to 1190 rpm</p> <p>Concave Type..... 12-Bar Open Type or Spike- Tooth Type Width..... 30 In.</p> <p>Beater (Behind the Cylinder) Type..... Wing Width..... 30 In.</p>	<p>Speed..... 680 rpm</p> <p>Separator Type..... Grain Conveyor, Straw Walker Width..... 30 In. Length of Separating Surface... 140 In. (Straw Walker Pans Extended)</p> <p>Area of Separating Surface... 4,200 Sq. In.</p> <p>Grain Conveyor Type..... Slat Drive..... Chain</p> <p>Cleaning Fan Type..... 5-Bladed Under- shot Drive..... V-Belt Speed of Range.... 602 rpm to 858 rpm</p> <p>Chaffer Type..... Adjustable, No. 2, No Choke, or Petersen Ad- justable Width..... 28-1/2 In. Length..... 48-1/2 In. Area..... 1,382-1/4 Sq. In.</p> <p>Sieve Type..... Adjustable Width..... 28-1/2 In. Length..... 45 In. Area..... 1,282-1/2 Sq. In.</p> <p>Chaffer Extension Type..... Adjustable Width..... 28-1/2 In. Length..... 12 In. Area..... 342 Sq. In.</p> <p>Total Cleaning Area of Chaf- fer, Sieve and Chaffer Ex- tension..... 3,007 Sq. In.</p> <p>Straw Walkers Number..... Three Width..... 9-1/2 In. Length..... 115 In.</p>	<p>Area..... 3,277-1/2 Sq. In.</p> <p>Number of Steps..... Five Drive..... V-Belt Bearings.... Oil-Soaked Maple</p> <p>Extension Pans..... One on Each Walker</p> <p>Grain Tank Capacity.... 55-Bushel, Ap- prox. (Type and Condition of Crop will Determine Ac- tual Volume)</p> <p>Capacity with Grain Tank Extensions (Special Equipment). 65-Bushel</p> <p>Type of Un- loading... Hinged Auger</p> <p>Weights Engine-Driven Combine with 12-Ft. Cutting Platform.. 6,965 Lbs.</p> <p>PTO-Driven Combine with 12-Ft. Cutting Platform.. 5,950 Lbs. (Ap- prox.)</p> <p>Capacities (Approx.) Fuel Tank... 40 U. S. Gallons Cooling Sys- tem (Ra- diator).... 6 U. S. Gallons Engine Crankcase. 4 U. S. Quarts Oil Filter... 1 U. S. Quart Air Cleaner.. 1 U. S. Quart Hydraulic Unit (In- cluding Hydraulic Oil Lines and Cyl- inders).... 7 U. S. Quarts</p> <p>Combine Di- mensions... See Pages 4 and 5</p>
--	--	---

COMBINE DIMENSIONS—OVER-ALL

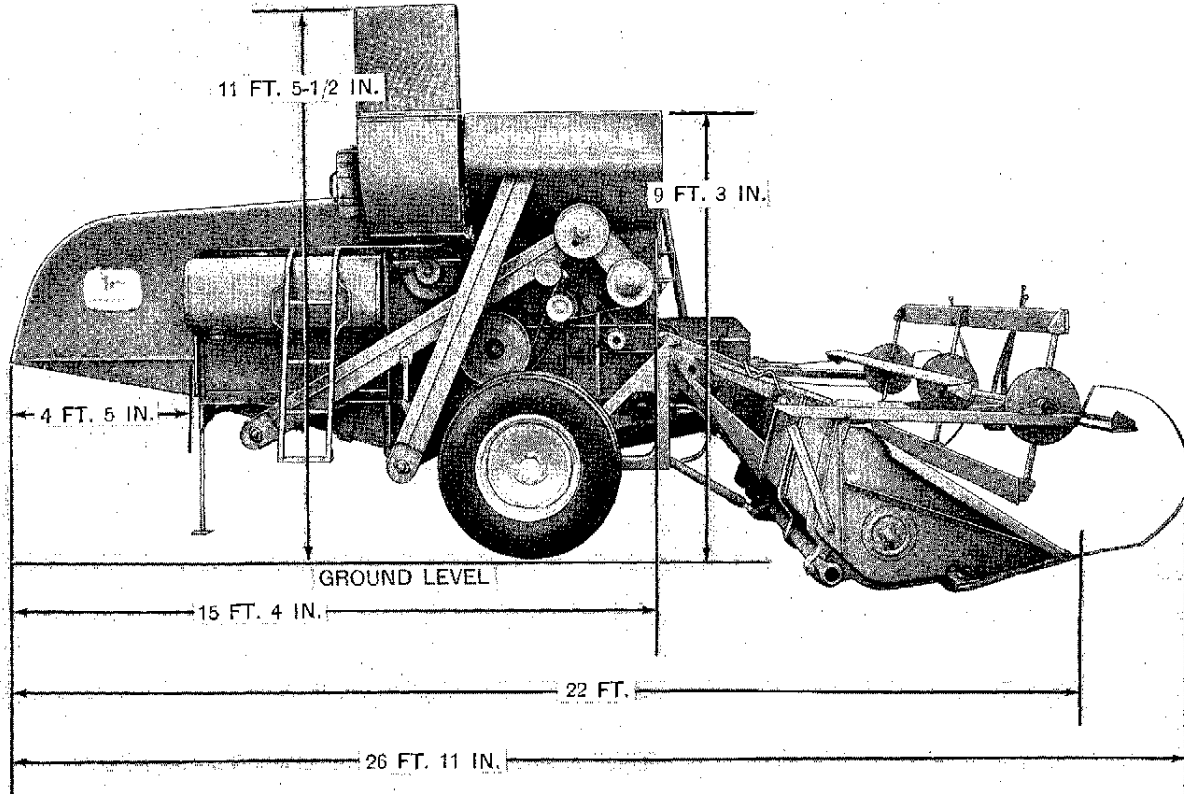

H 2528

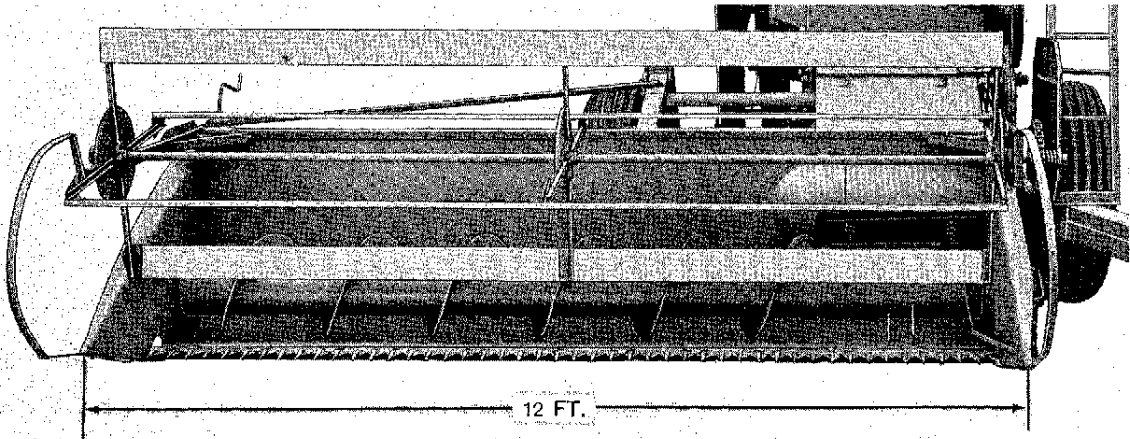

H 2529

COMBINE DIMENSIONS—OVER-ALL—Continued

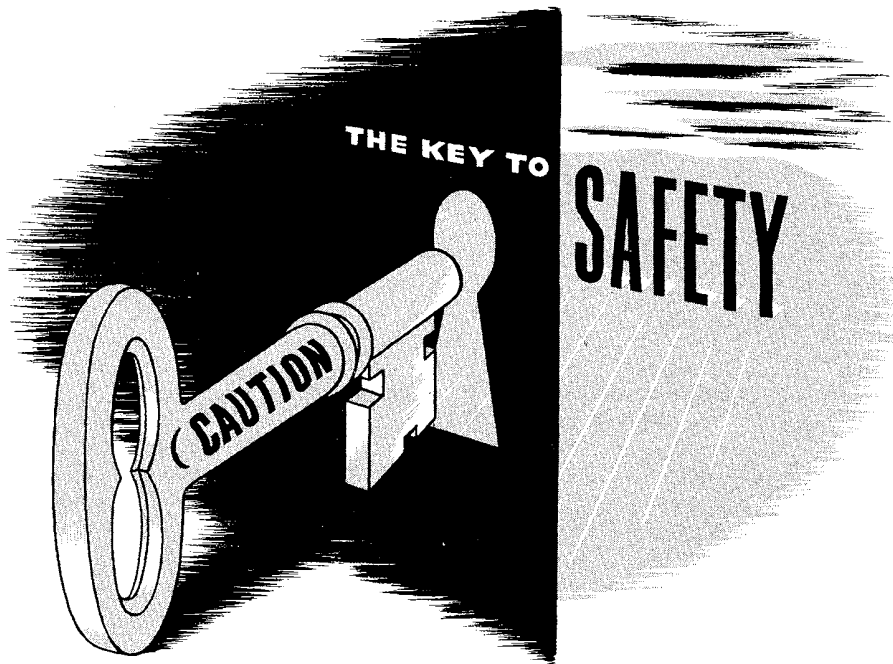
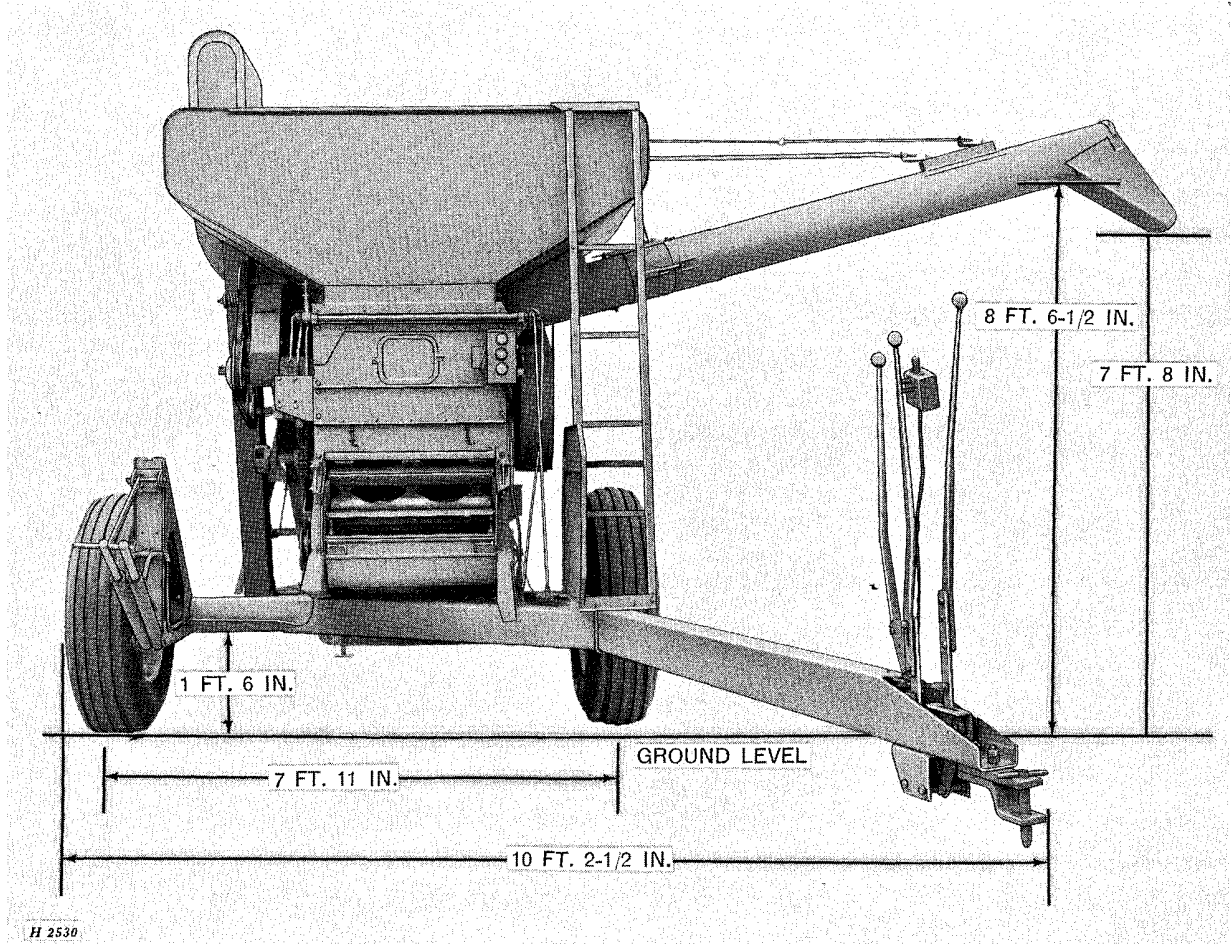

ENGINE

Make of Engine	John Deere—HE-217-G	Valve Arrangement	Valve-in-Head (Rotators on Exhaust Valves)
Bore	3-5/8 In.	Valve Clearance In- take012-In. (When Cold)
Stroke	3-1/2 In.	Exhaust018-In. (When Cold)
Brake Horsepower*	71-1/2	Make of Governor	Pierce
Number of Cylinders	6	Make of Carburetor	Marvel-Schebler
Piston Displacement	217 Cu. In.	Spark Plug	Champion H-10 or Auto-Lite AL-7 or AC-45L Gap .025- In. Heat Range 1200° to 1500°F.
Max. Load Speed	2200 rpm	Electrical System	12-Volt (Two 6-Volt Batter- ies)
Firing Order	1-5-3-6-2-4	Cooling System	Water Pressure Type
Crankcase	Cast Integral with Block	Type of Fuel	Gasoline (Regular Grade)
Type of Lubrication	Force Feed by Gear Pump to All Connecting Rods, Main Bearings, Governor, and Oil Pump Drive. Oil Strainer in Bottom of Pan		

*Calculated at 60° F. and 29.92 inches Hg. at Sea Level.

SPECIAL EQUIPMENT AVAILABLE

	<i>Page</i>		<i>Page</i>
Adjustable Parking Stand	17	Perforated Elevator Connections and Clean- Out Doors	67
Auxiliary Chaffer, Lip Type	63	Reel End Shields	36
Belt Pickup Attachment	43	ScourKleen	72
Belt Wipers for Reel Slats	37	Shoe Dividers	63
Chaffers (Special Types)	62	Sieves (Special Types)	64
Chain Detacher	79	Spike-Tooth Straightener	47
Cleaning Fan Housing Protective Shield	61	Spike-Tooth Wrench	47
Concave Cover Plates	50	Spinning Fan Screens	61
Cutter Bar Guard Straightener	40	Steel Elevator Paddles	66
Engine Cover	102	Stone Trap	53
Feeder Conveyor Chain Shield Extension	42	Straw Chopper	71
Feed Rolls Attachment	57	Straw Chopper Reverse Drive	72
Grain Tank Extension	72	Straw Spreader	70
Guard and Knife Repair Block	40	Tailings Finger Bar with Adjustable Tailboard	63
Lifting Guards	40	Thermostat, Cold Weather	100
Platform Auger Flight Extension	41		

(Specifications and design subject to change without notice.)

LUBRICATION

The economical and efficient operation of any machine depends on regular and proper lubrication of all moving parts with a quality lubricant. This is especially true of farm equipment which must operate in hot, dusty conditions over rough ground. Neglected lubrication quickly leads to reduced efficiency, heavy draft, wear, breakdown, and replacement of parts.

Use a clean container for storing and handling all lubricants. See that only clean lubricants go into the working parts of your combine.

LUBRICATION CHARTS

All lubrication points will be found in the lubrication charts that follow.

For all hourly lubrication points, use SAE multipurpose grease.

CAUTION: Never Attempt to Lubricate Combine or Engine While Engine Is Running.

Wipe dirt from grease fittings and grease gun nozzle before greasing.

Replace all missing or damaged grease fittings immediately.

BEARINGS

Lubricate all grease fittings thoroughly, with SAE multipurpose grease, until grease oozes out of bearing. This assures that the bearing is full, and also flushes out dirt that may have accumulated in the bearing. However, avoid excessive lubrication. Excessive lubricant that has dropped onto belts should be wiped off immediately to avoid belt slippage.

Two types of sealed bearings are used on this combine. One type is a sealed for life bearing which requires no lubrication; the other type is pre-packed at the factory and will require yearly lubrication.

To lubricate bearings where a pipe plug is provided in bearing housing, remove the pipe plug and insert a 1/8-inch diameter slotted grease fitting (JD7805); the slotted fitting allows the bearing housing to be filled to capacity without blowing out seals due to pressure building up. Then remove grease fitting and replace pipe plug.

Where no end cap or pipe plug is provided in bearing housing, it will be necessary to pull bearing housing from shaft to repack bearing with new grease. Clean bearing with a safe solvent and pack with new grease. Replace bearing housing.

LUBRICATION OF LINKAGES

When lubricating the combine, make a practice of putting a few drops of SAE 10 engine oil on all clevises, linkages, and other moving parts. This will make them work easier and prolong their life.

LUBRICATION OF CHAINS

Chains should be lubricated at frequent intervals. A good grade of SAE 10 oil should be used. A paint brush is a good instrument for applying oil to chains. **CAUTION: Do not oil chains when operating in sandy conditions. Sand will stick to the oiled chain and act as an abrasive.**

KNIFE LUBRICATION

The amount of lubricant to use on a knife depends on the conditions in which the work is being done. When the grain is being topped and the cutter bar is carried some distance from the ground, liberal lubrication with SAE 10 engine oil is permissible. In many conditions where the cutter bar must operate close to the ground, it is better not to use oil except for a small amount on the knife holders.

ENGINE LUBRICATION

TYPES OF CRANKCASE OIL.

The engine of your combine has a force-feed pressure lubricating system—one of the finest it is possible to produce. Do not handicap it by trying to save money with inferior oil. High-grade oils withstand heat and wear for a longer time. Inferior oils soon become thin and lose their lubricating qualities. Some inferior oils contain traces of sulphur, which in itself is not harmful, but in the presence of certain products of combustion, will form acids which will attack metal surfaces. It pays to buy only nationally-known brands of oil.

It is impossible to determine from the appearance of an oil whether it is best suited to your engine and service conditions. The petroleum industry markets several types of crankcase oils. These types have been defined by the American Petroleum Institute as follows:

Service ML—Oil suitable for service typical of gasoline and other spark ignition engines operating under light loads and favorable service conditions.

Service MM—Oil suitable for service typical of gasoline and other spark ignition engines operating under moderate to severe service conditions.

Service MS—Oil suitable for service typical of gasoline and other spark ignition engines operating under unfavorable or severe types of service conditions.

ENGINE LUBRICATION—Continued

For average service conditions, oil specified "For Service MM" is recommended for use in your combine engine.

For exceptionally severe service, combinations of heavy loads and high temperatures, or low temperature start and stop service, it may be possible to extend engine life by use of oils specified "For Service MS."

In some cases, where owners have had successful experience with certain brands of oils now specified "For Service ML," it will be possible to continue use of these oils but, due to the wide variations likely to be encountered among various brands, their use cannot be generally recommended.

VISCOSITY OF OIL.

Your John Deere Combine was made with the same precision as a fine automobile, with clearances between bearing surfaces as fine as a ten-thousandth part of an inch. If oil is expected to lubricate these surfaces, it first must get there. Therefore, viscosity of the oil is very important.

Using oil of the wrong viscosity can result in loss of power, excessive fuel consumption, and undue wear on moving parts.

In a new engine it is important to use the oil specified in the temperature-oil viscosity chart.

IMPORTANT: Follow the engine break-in instructions given on this page and page 20.

Season	Engine Crankcase, Air Cleaner, and Hydraulic Systems
Above 32° F.	SAE 20 or SAE 10W-30
Below 32° F.	SAE 10-10W or SAE 5W-20

Capacities:

Crankcase Oil Capacity 4 U. S. Quarts
 Oil Filter Capacity 1 U. S. Quart
 Cutting Platform Lift and Variable Drive Hydraulic Unit Oil Capacity* 7 U. S. Quarts
 Air Cleaner 1 U. S. Quart

*This includes hydraulic oil lines and cylinders.

HYDRAULIC UNITS.

A premium grade of engine oil is recommended for use in the hydraulic unit. Check oil level daily. Be certain the cutting platform is lowered to the ground when checking or adding oil.

ENGINE BREAK-IN.

The engine on your new combine is shipped from the factory with a special break-in oil in the crankcase. After 20 hours of operation, this oil must be drained from the crankcase and oil filter and replaced with 5 quarts of oil. Use SAE 10W or SAE 5W-20 if temperature is below +32° F. or SAE 20 or SAE 10W-30 if temperature is above +32° F.

Drain and replace oil every 150 hours of operation, or every season (whichever comes first), thereafter. Use the correct oil as specified above, depending on the temperature. For further break-in instructions on the engine, see page 20.

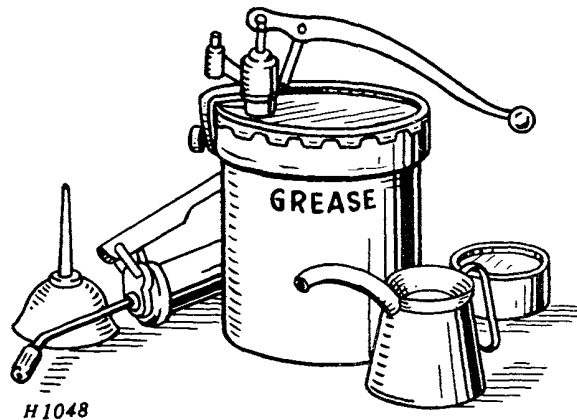





KEEP LUBRICANTS CLEAN!

Use *only* high-grade lubricants which have been stored in clean containers. Wipe away all grease and dirt before removing filler caps or plugs.

SEPARATOR

(ENGINE-DRIVEN COMBINE ONLY)



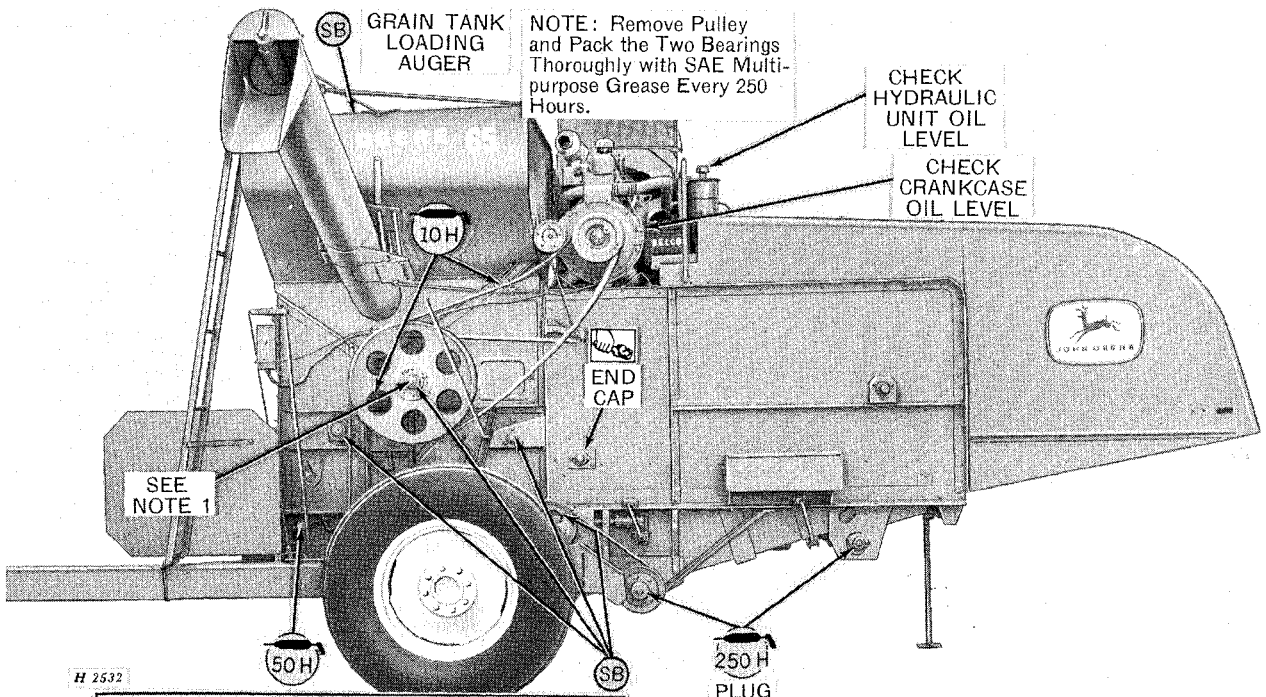
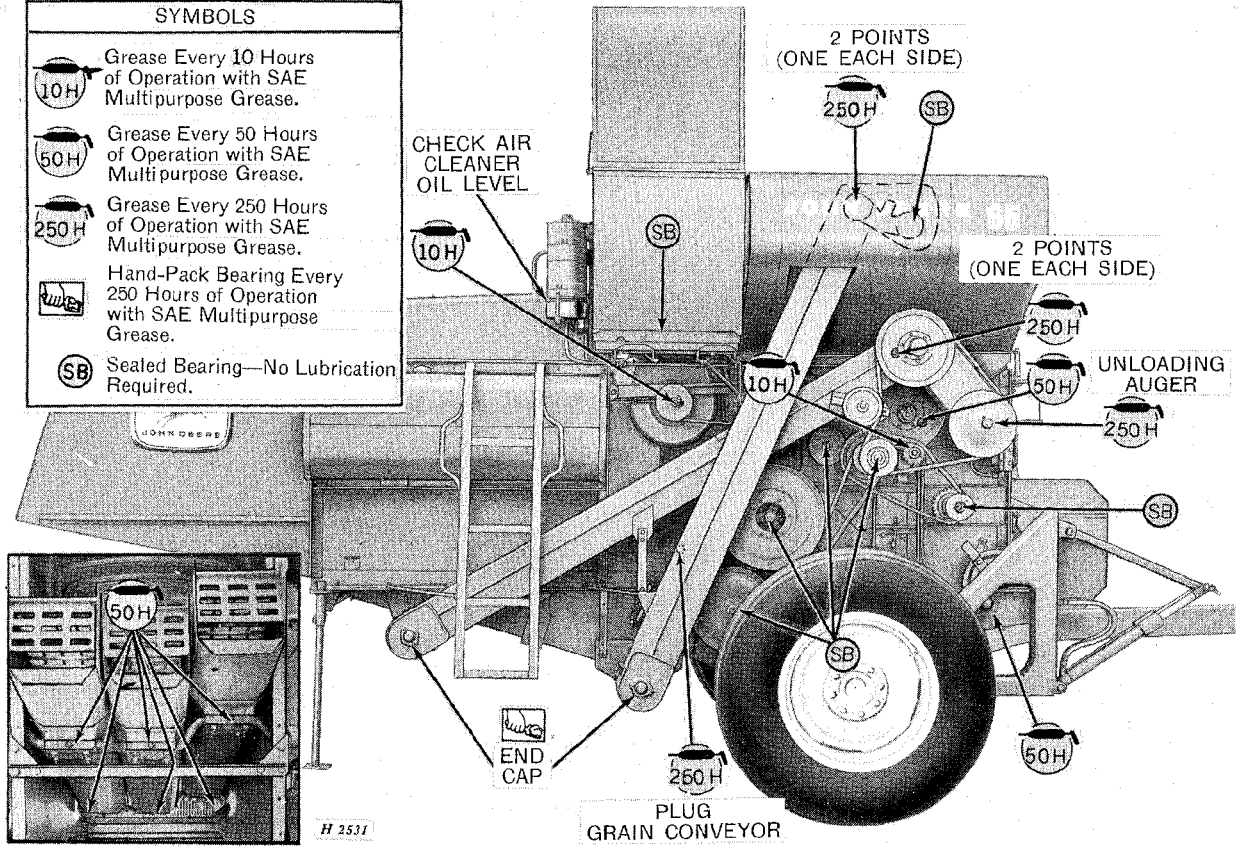

SYMBOLS	
	Grease Every 10 Hours of Operation with SAE Multipurpose Grease.
	Grease Every 50 Hours of Operation with SAE Multipurpose Grease.
	Grease Every 250 Hours of Operation with SAE Multipurpose Grease.
	Hand-Pack Bearing Every 250 Hours of Operation with SAE Multipurpose Grease.
	Sealed Bearing—No Lubrication Required.



NOTE 1: On Combines Equipped with Electromagnetic Clutch, Grease with SAE Multipurpose Grease.

SEPARATOR

(PTO-DRIVEN COMBINE ONLY)

SYMBOLS	
	Grease Every 10 Hours of Operation with SAE-Multi-purpose Grease.
	Grease Every 25 Hours of Operation with SAE Multi-purpose Grease.
	Grease Every 250 Hours of Operation with SAE Multi-purpose Grease.
	Hand-Pack Bearing Every 250 Hours of Operation with SAE Multipurpose Grease.
	Sealed Bearing--No Lubrication Required.

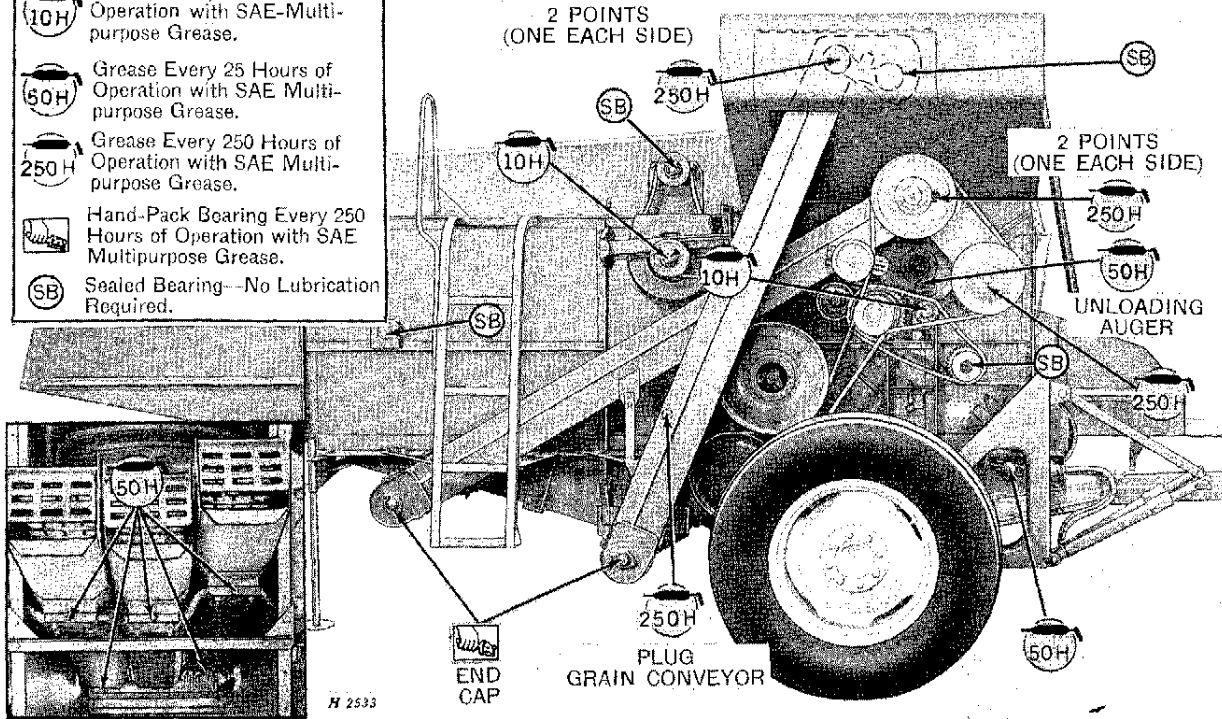

NOTE 1: On Combines Equipped with Electromagnetic Clutch, Grease with SAE Multipurpose Grease.

NOTE 2: Remove Tightener Pulley and Pack the Two Bearings Thoroughly with SAE Multipurpose Grease Every 250 Hours of Operation.

NOTE 3: Check Gear Case at Oil Level Plug Every 10 Hours of Operation. If Necessary Fill with SAE 90 Multipurpose Gear Lubricant.

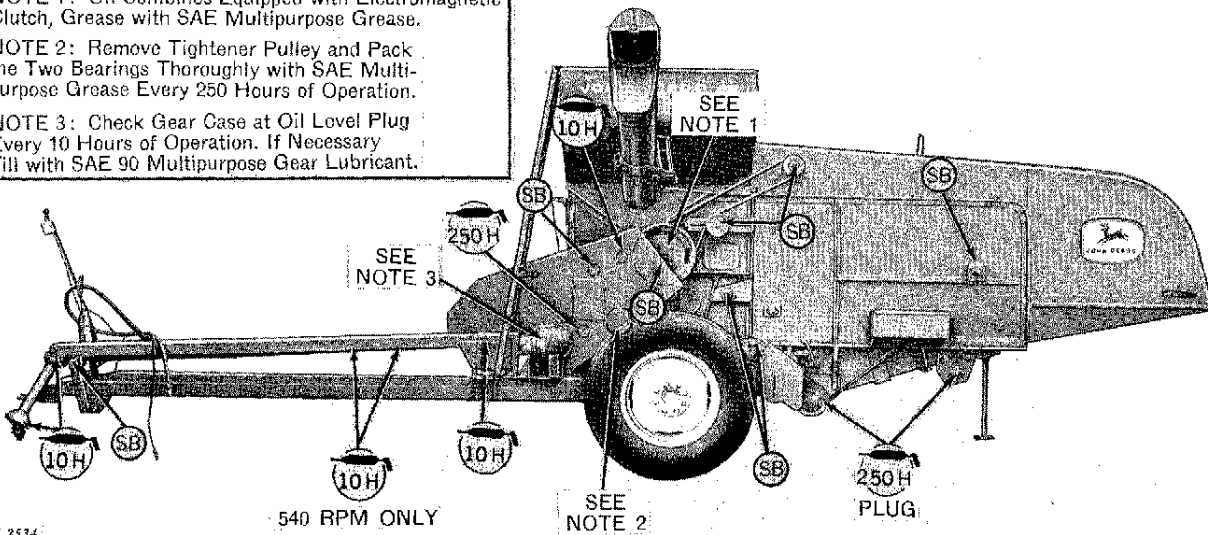

CUTTING PLATFORM



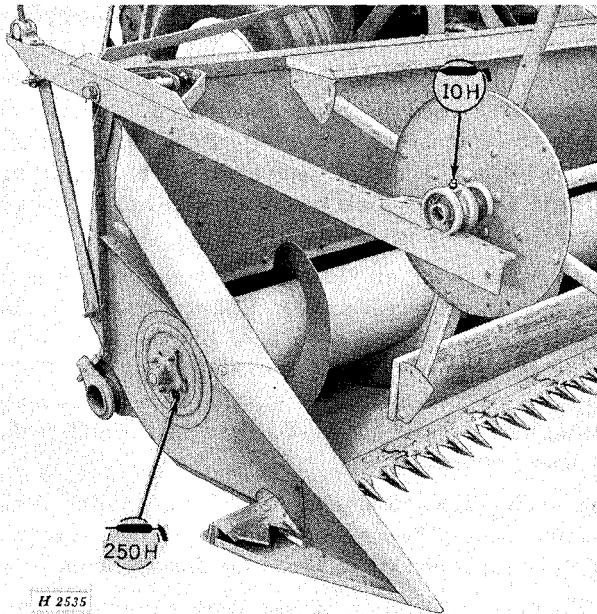

(PTO-DRIVEN AND ENGINE-DRIVEN COMBINES)

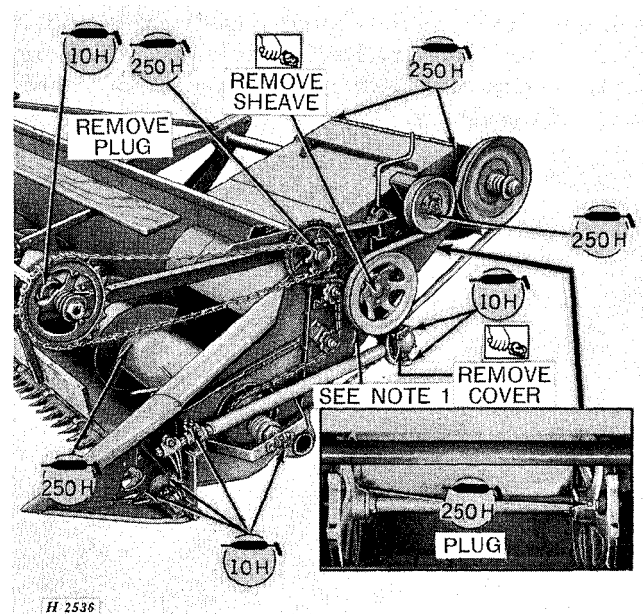
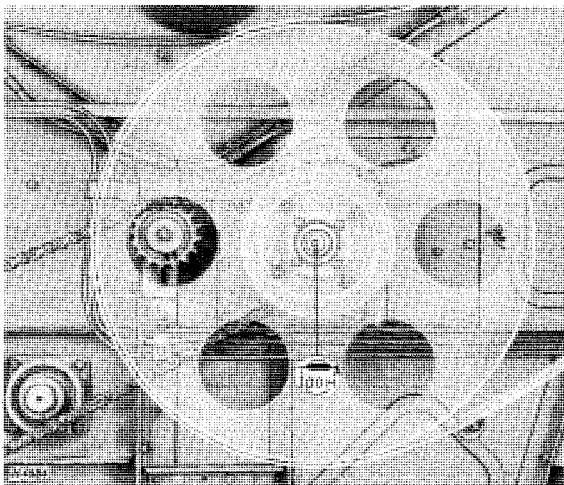

ELECTROMAGNETIC THROWOUT CLUTCH



SYMBOLS

-  Grease every 10 hours of operation with SAE multipurpose grease.
-  Grease every 100 hours of operation with SAE multipurpose grease.
-  Grease every 250 hours of operation with SAE multipurpose grease.
-  Hand-pack bearing every 250 hours of operation with SAE multipurpose grease.

NOTE 1: Pry off end cap and remove cotter and nut from right-hand end of shaft. Pull shaft out from left-hand side to expose right-hand bearing.

AIR CLEANER

The air cleaner requires attention every day of combine operation. **IMPORTANT:** When operating under extremely dusty, sandy conditions, or in crops that are heavy with rust, fuzz, or dirt, service air cleaner twice a day, or more often if necessary.

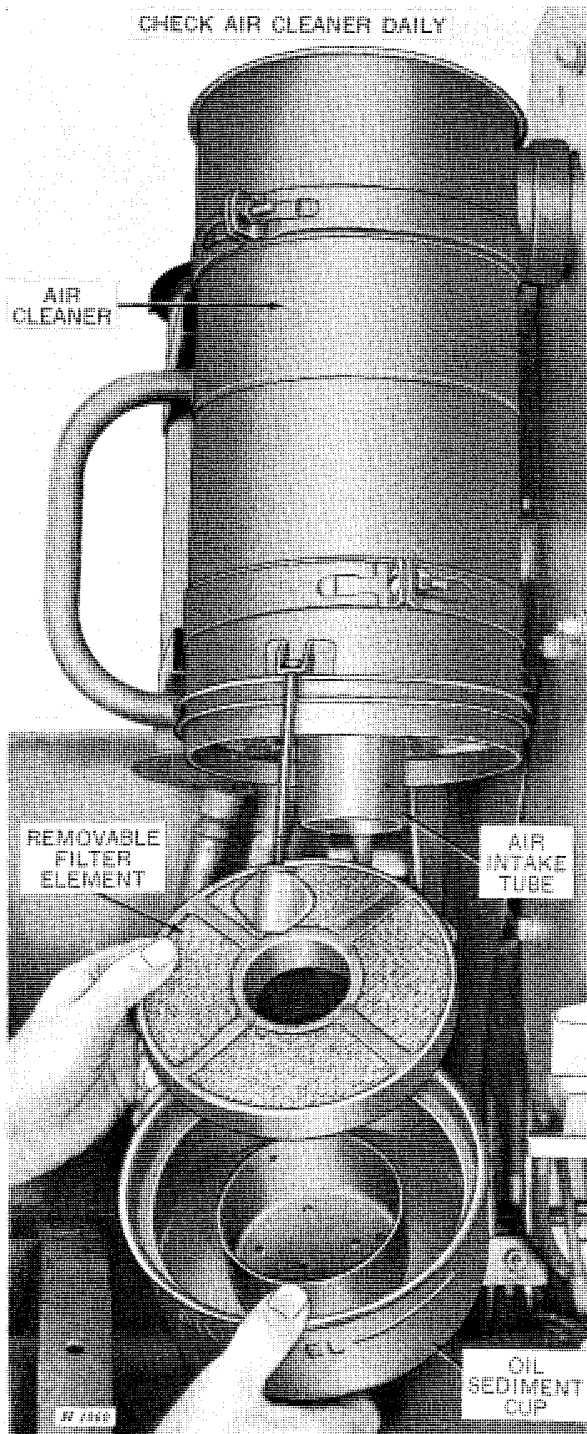

SERVICING AIR CLEANER.

Remove oil sediment cup from lower part of air cleaner; remove removable filter element from cup, then pour out oil and sediment. Wash sediment cup and filter element in a safe cleaning solvent. Refill cup with new oil to oil level mark. Use an oil of same viscosity as used in crankcase, except in extreme dusty conditions—then use only SAE 10 engine oil. **CAUTION:** If oil is above oil level mark on cup, it will be drawn from air cleaner through carburetor up into engine.

When servicing air cleaner, check connecting hose from air cleaner to carburetor. Connections should be air tight at all times, with hose placed as far onto horns of carburetor and cleaner as possible. Tight connections will permit engine to use washed air through air cleaner instead of dirty air through leaks in hose connections.

The air intake tube (running through center of air cleaner) should be swabbed out at regular intervals to allow sufficient air to pass into the air cleaner.

To swab out the air intake tube, remove oil cup from bottom of cleaner, then swab out tube with a clean cloth wrapped around a stick.

At the end of operating season, remove entire air cleaner from combine so all parts may be washed in a safe cleaning solvent. This will remove any dirt which may be clinging to oily surfaces of the interior of air cleaner.

CAUTION: Do not remove cleaning element from air cleaner. Do not attempt to dry air cleaner with an air hose. The blast will compact the filtering material.

HYDRAULIC UNITS

Check Oil Level of Hydraulic Oil Reservoir Daily.

Use a premium-type engine oil of the proper viscosity. See chart on page 8 for weights of oil to use in different temperatures.

CAUTION: Add only clean oil of the proper viscosity to the hydraulic unit oil reservoir. **NEVER USE DRAININGS OF ANY TYPE.** If oil is to be strained when added, never strain through cloth as lint is harmful to the hydraulic system.

An extreme pressure oil is used as a shipaway oil in the hydraulic unit. After one season's operation, drain and refill hydraulic system with a premium-type engine oil of proper viscosity.

HYDRAULIC UNIT OIL LEVEL.

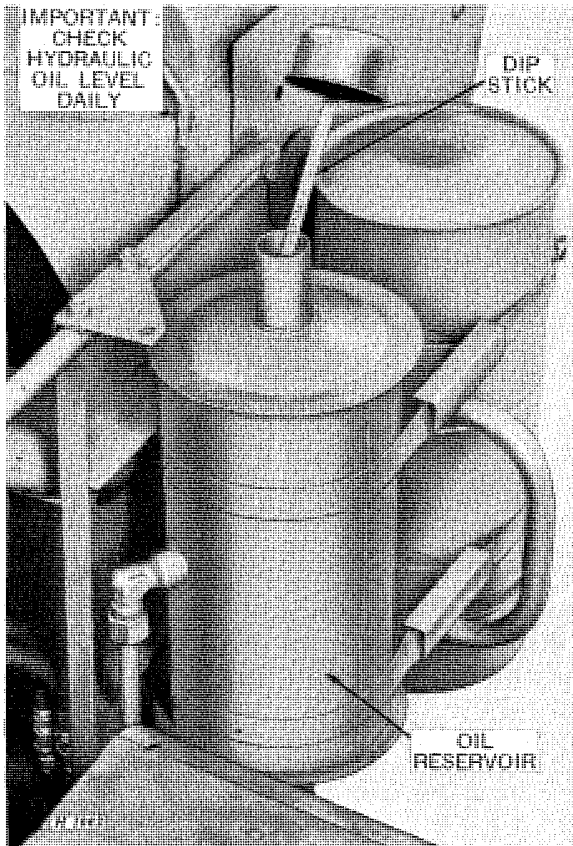

Hydraulic Unit Reservoir and Dip Stick

NOTE: Be certain cutting platform has been lowered to the ground before checking oil level.

Oil level should be to "Full" mark on dip stick attached to oil reservoir cap. Add clean oil as necessary, of the same viscosity as used in the engine crankcase.

Capacity of hydraulic system, including oil lines and cylinders, is approximately 7 U. S. quarts.

CRANKCASE

CHECKING CRANKCASE OIL LEVEL.

A bayonet gauge for checking the quantity of oil in crankcase is provided on lower right-hand side of engine. It is not necessary to add oil until oil level is down to "Add One Qt." mark on bayonet gauge. Do not operate engine with oil level below the "Add One Qt." mark.

Check oil level daily. If oil is above "Full" mark on bayonet gauge, drain to level of drain plug in oil pan. Check oil level immediately after stopping engine.

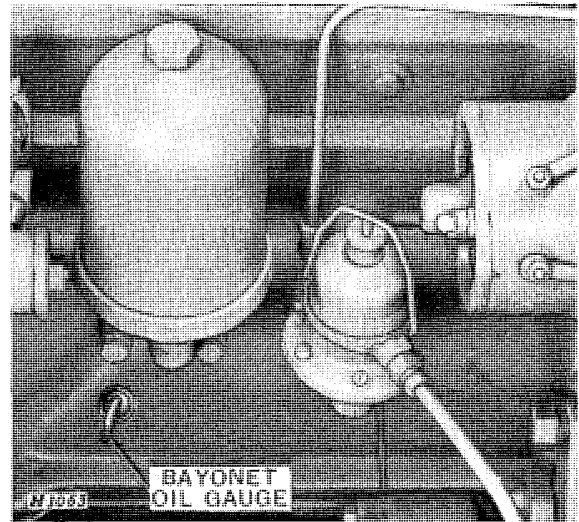

Bayonet Oil Gauge

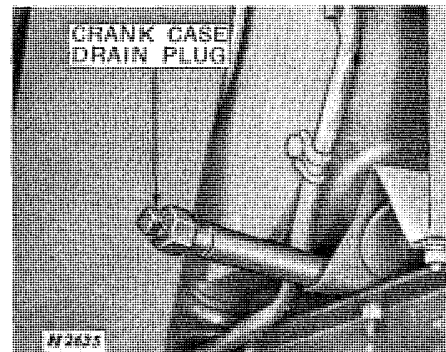

Crankcase Drain Plug

DRAINING CRANKCASE.

After every 150 hours of operation, crankcase oil should be drained, and oil filter element replaced. Oil should be drained, when the engine is hot and before sludge has settled, as the oil will flow more freely, carrying off more sediment. When changing oil, it is not advisable to flush out the crankcase with kerosene as it is impossible to drain out all the kerosene without dropping the pan. Traces of kerosene will remain to dilute the fresh oil.

Filling Crankcase.

After all the old oil has drained from the crankcase, reinstall the drain plugs in the crankcase and oil filter. Refill crankcase with new engine oil of proper viscosity. Crankcase holds 4 U. S. quarts of oil and approximately one quart more will be required for oil filter. When the 5 U. S. quarts of oil have been poured into the crankcase, oil level on the bayonet gauge will show approximately one quart above the "FULL" mark. However, after engine has

run a short time, the extra oil will be pumped into the oil filter element and oil passages of the engine. Then the oil level will be at "FULL" mark on bayonet gauge. Check oil level immediately after stopping engine.

REPLACING OIL FILTER ELEMENT

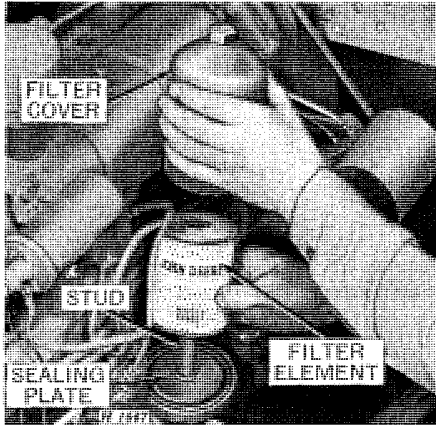

Replacing Oil Filter Element

Remove drain plug at bottom of oil filter (be sure to have a quart size container handy to catch oil). Turn stud at top of oil filter case approximately three or four turns with wrench, then tap around case using a soft hammer to loosen seal. Remove filter case. Pull out and discard old filter element, being certain that lower sealing plate is not stuck to bottom of old filter element. Without this sealing plate, filter cannot function properly. If plate is discarded, a new one should be obtained immediately.

The filter element fits over a long stud. If this stud is bent, straighten it by tapping with a soft hammer. Install new filter element. Be certain to tighten stud nut securely.

NOTE: John Deere engineers have made exhaustive tests on all types, makes, and kinds of oil filters to find a filter which will keep oil free from contamination for the longest operating period. These tests have proved that the replacement oil filter (AH-1111-RT) recommended and supplied by your John Deere dealer, is most effective.

GENERATOR

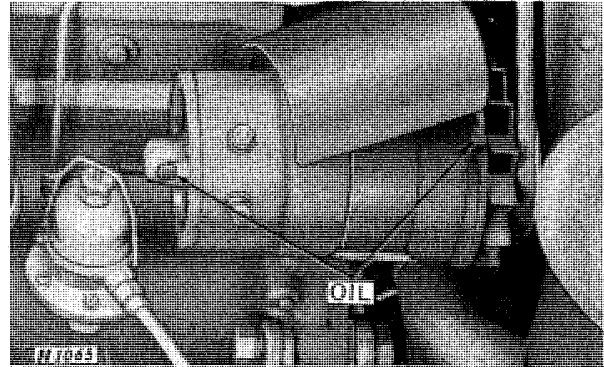

Generator

Lubricate the generator by filling front and rear oil cups with SAE 10 engine oil. This lubrication service should be performed only with engine stopped.

CAUTION: Never over-lubricate any electrical unit on your combine. More damage to electrical equipment has been caused by over-lubrication than by lack of oil.

REMEMBER

Good Oil Changed Frequently—Oil Filter Elements Replaced Often—Breather and Air Cleaner Kept Clean and Functioning Properly—and Engine in Good Adjustment—Means Longer Life to the Engine and Trouble-Free Operation.

CRANKCASE AND HYDRAULIC UNIT BREATHER CAPS

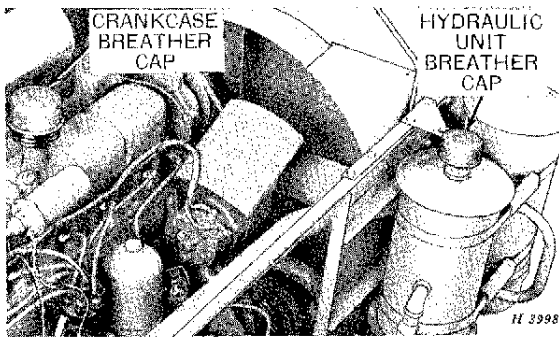

Crankcase and Hydraulic Unit Breather Caps

The breather caps serve as covers for the crankcase and hydraulic unit breather tubes. They should be washed in a safe solvent every 150 hours of operation. Engine should not be started nor hydraulic unit operated unless breather caps are properly installed.

DISTRIBUTOR

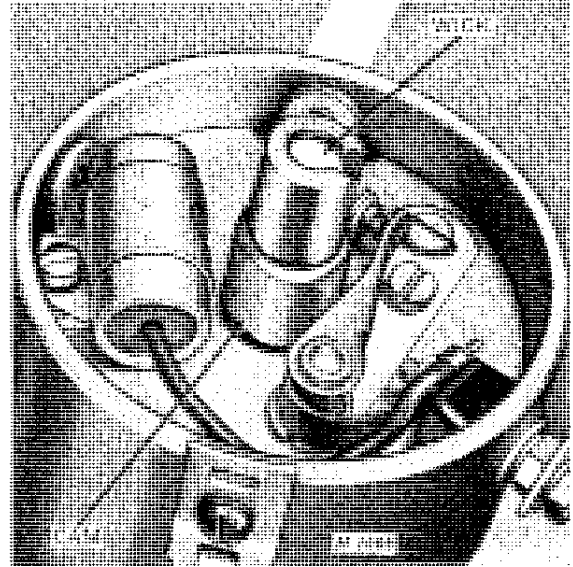

Distributor with Cap Removed

Apply a trace of SAE multipurpose grease to the distributor cam, and place 4 or 5 drops of SAE 10 engine oil on the wick.



Suggest:

If the above button click is invalid.

Please download this document

first, and then click the above link

to download the complete manual.

Thank you so much for reading

OPERATION

COMBINE CONTROLS

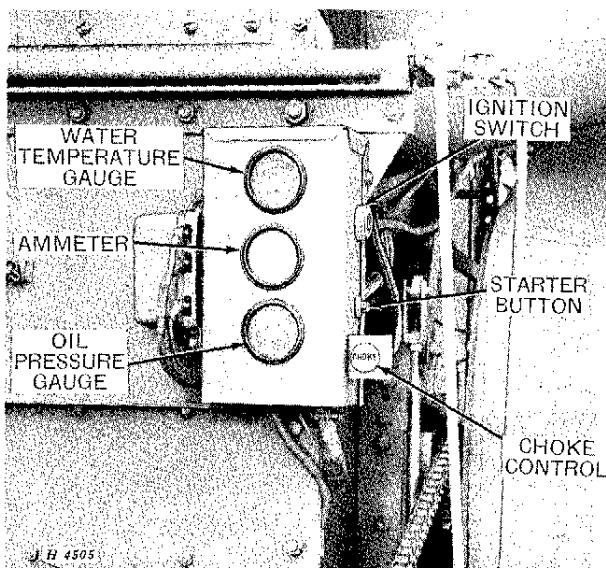

OIL PRESSURE GAUGE (Engine-Driven Combines)

This gauge indicates the pressure of engine lubricating oil—not the amount of oil in the crankcase. Oil pressure will vary slightly with wear but with recommended oil it should read **normal** at full governed speed. If **oil pressure drops, stop immediately and determine cause.**

WATER TEMPERATURE GAUGE (Engine-Driven Combines)

This gauge indicates the water temperature in the cooling system—not the quantity. Normal operating temperature is 160° to 200°F. (Indicated by green band on dial.) If 200° or above (Indicated by red band on dial) stop engine and determine cause.

AMMETER (Engine-Driven Combines)

This gauge indicates the rate of charge or discharge of the battery. If ammeter shows discharge for an extended period during normal operation, check for a ground, short circuit or faulty regulator. If ammeter shows charge continually, inspect for low battery, faulty connections, low battery water, or bad regulator.

CHOKE CONTROL BUTTON (Engine-Driven Combines)

Pull button all the way out to start engine. After engine is started, and for normal operation, push button all the way in.

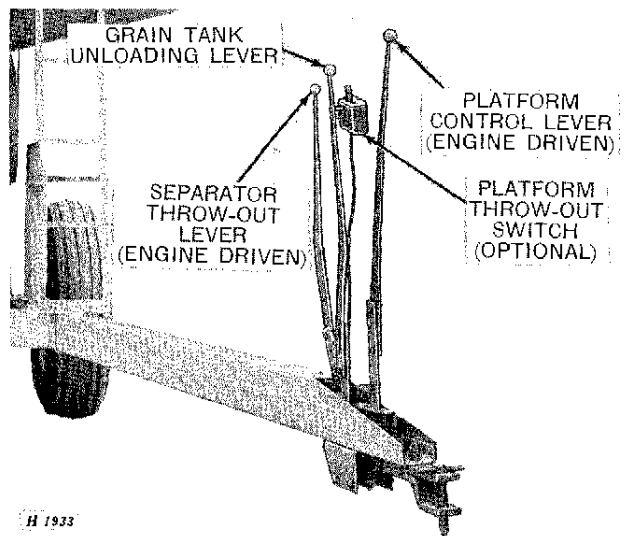

out clutch which permits stopping the platform and feeder while the separator continues to run. This control is available as special equipment for both engine-driven and PTO-driven combines.

SEPARATOR THROW-OUT LEVER (Engine-Driven Combines)

Move lever forward to engage separator. When separator is engaged, throttle control linkage between separator belt tightener and engine automatically increases engine speed to full throttle.

NOTE: On PTO-driven combines, separator is engaged by engaging tractor PTO.

PLATFORM CONTROL LEVER (Engine-Driven Combines)

This lever is within easy reach from any tractor seat and controls the range of platform height from 2 to 30 inches from the ground. When released, it automatically returns to neutral position with platform remaining at the desired position. To raise platform, move lever back—to lower platform, move lever ahead. For safe operation, platform cannot be operated unless engine is running.

NOTE: On PTO-driven combines, the platform height is controlled by the tractor hydraulic system.

GRAIN TANK UNLOADING LEVER

This control is provided on both engine-driven and PTO-driven combines. Move lever back to engage unloading auger drive.

NOTE: On engine-driven combines if grain tank

<https://www.ebooklibonline.com>

Hello dear friend!

Thank you very much for reading.

Enter the link into your browser.

The full manual is available for immediate download.

<https://www.ebooklibonline.com>