

JOHN DEERE 65 AND 96 COMBINES



OPERATORS MANUAL JOHN DEERE 65 AND 96 COMBINES

OMH91062 K5 English

JOHN DEERE HARVESTER WORKS
OMH91062 K5

LITHO IN THE U.S.A. (REVISED)
ENGLISH



TO THE PURCHASER

The combine you have purchased has been carefully designed and manufactured to provide years of dependable, economical service.

To further insure trouble-free service we recommend that you follow closely all instructions concerning operation, lubrication, adjustments and service. Preventive maintenance has proved to be much more economical than corrective maintenance. Should you require information not covered in this manual, consult your John Deere dealer.

KEEP YOUR COMBINE A JOHN DEERE COMBINE

Genuine John Deere Parts fit properly and insure satisfactory service because they are made from the original patterns and from the same material as used in new machines. Should your combine require replacement parts, go to your John Deere dealer where you can obtain Genuine John Deere Parts—accept no substitutes.

ATTACHMENTS

In addition to the equipment furnished with your combine, there are attachments available to help you do a better job in a special crop or condition. These attachments, illustrated and described in the attachment section, are available from your John Deere dealer.

LOCATION REFERENCE

"Right-hand" and "left-hand" sides are determined by facing in the direction the combine will travel when in use.

SERIAL NUMBERS

Your combine and platform have serial numbers.

When ordering parts, always bring with you the model and complete serial numbers as given on the serial number plates. By doing so, you will assist your John Deere dealer in giving you prompt, efficient service.

The combine serial number is on a plate located on the grain tank unloading auger counter-shaft left-hand support bracket.

The platform serial number is on a plate located on the outside of the right-hand platform divider.

Record these Serial Numbers in the space provided below.

Combine serial no. _____

Platform serial no. _____

Date Purchased _____

CONTENTS

	Page		Page
<i>Specifications</i>	2	<i>Adjustments and service</i>	24
<i>Controls and instruments</i>	5	<i>Trouble shooting</i>	46
<i>Operation</i>	6	<i>Attachments</i>	53
<i>Safety suggestions</i>	14	<i>Index</i>	55
<i>Lubrication and periodic service</i>	15		

Operator's Manual Price

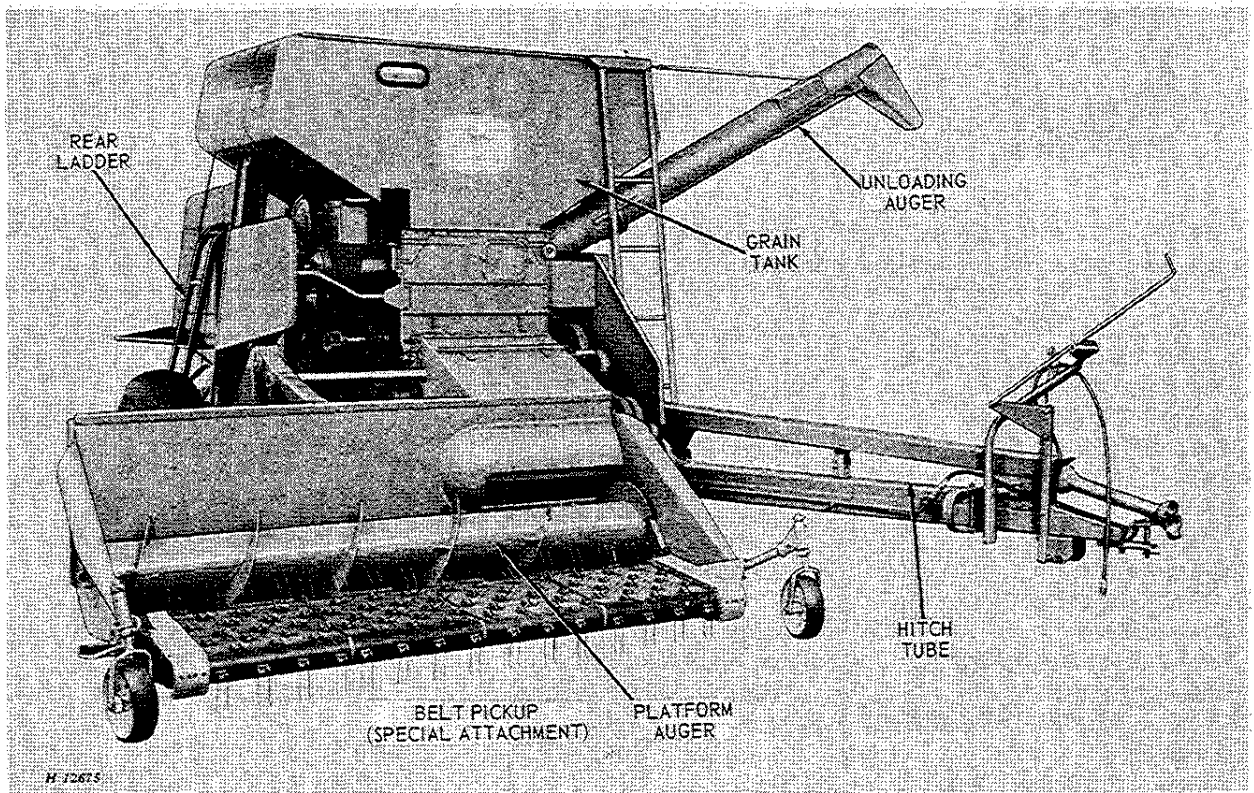

John Deere 65 Combine

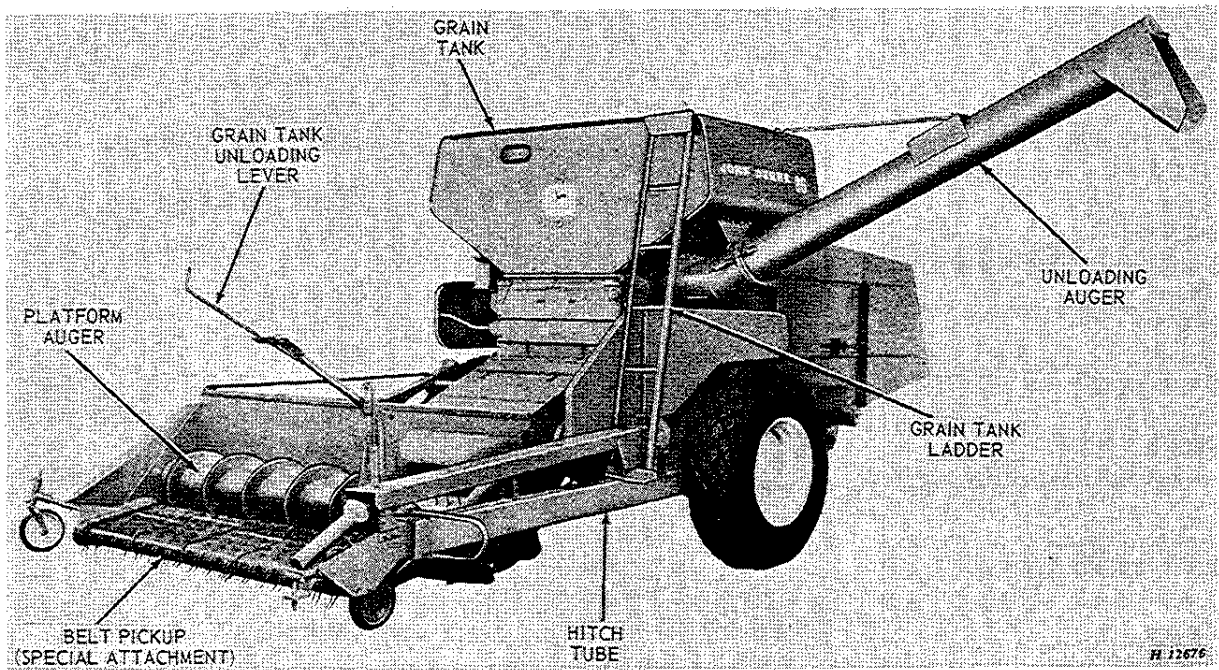

John Deere 96 Combine

<https://www.ebooklibonline.com>

Hello dear friend!

Thank you very much for reading.

Enter the link into your browser.

The full manual is available for immediate download.

<https://www.ebooklibonline.com>



SPECIFICATIONS

NOTE: The 96 Combine platform is available as a pickup platform, with additional parts available to convert to a cutting platform when desired.

Description	65 Combine	96 Combine
CUTTER BAR		
Width of cut	12 ft.	12 ft.
Length of cutter bar	6 inches less than width of cut	6 inches less than width of cut
Type of knife sections	Heavy-duty overserrated	Heavy-duty overserrated
REEL		
Drive	Chain	Chain
Number of slats	4 regular; 3, 6 or 8 special	4 regular; 3, 6 or 8 special
Speed range	28.1 rpm to 36.1 rpm	18.5 rpm to 51.5 rpm
CUTTING PLATFORM		
Type of feed	Auger	Auger
Range of cutting height	2 in. to 30 in.	2 in. to 30 in.
Height control	Hydraulic (2 cylinders)	Hydraulic (2 cylinders)
CUTTING PLATFORM AUGER		
Diameter	20 in.	20 in.
Diameter of auger tube	10 in.	10 in.
Type of auger fingers	Round retracting	Round retracting
Belt pickup platform width	9 ft.	12 ft.
CYLINDER		
Type	Rasp bar	Rasp bar
Width	30 in.	40 in.
Diameter	22 in.	22 in.
Number of bars	8 rasp bars	8 rasp bars
Drive	Roller chain	Roller chain
Speed range	196 rpm to 1190 rpm	196 rpm to 1190 rpm
CONCAVE		
Type	12 bar open type	12 bar open type
Width	30 in.	40 in.
BEATER (Behind the cylinder)		
Type	Wing	Drum
Width	30 in.	40 in.
Speed	680 rpm	680 rpm
SEPARATOR		
Type	Grain conveyor, straw walker	Grain conveyor, straw walker
Width	30 in.	40 in.
Length of separating surface	140 in. (straw walker pans extended)	140 in. (straw walker pans extended)
Area of separating surface	4200 sq. in.	5600 sq. in.
GRAIN CONVEYOR		
Type	Slat	Slat
Drive	Chain	Chain

Description	65 Combine	96 Combine
CLEANING FAN		
Type	5-bladed undershot	5-bladed undershot
Drive	V-belt	V-belt
Speed range	602 rpm to 858 rpm	602 rpm to 858 rpm
CHAFFER		
Type	Adjustable, no. 2 no choke or Petersen adjustable	Adjustable, no. 2 no choke or Petersen adjustable
Width	28-1/2 in.	38-1/2 in.
Length with extension	48-1/2 in.	60-3/4 in.
Area	1382-1/4 sq. in.	2337 sq. in.
SIEVE		
Type	Adjustable	Adjustable
Width	28-1/2 in.	38-1/2 in.
Length	45 in.	45 in.
Area	1282-1/2 sq. in.	1734 sq. in.
CHAFFER EXTENSION		
Type	Adjustable	Adjustable
Width	28-1/2 in.	38-1/2 in.
Length	12 in.	12 in.
Area	342 sq. in.	462 sq. in.
TOTAL CLEANING AREA OF CHAFFER, SIEVE AND CHAFFER EXTENSION	3007 sq. in.	4071 sq. in.
STRAW WALKERS		
Number	Three	Four
Width	9-1/2 in.	9-1/2 in.
Length with pans extended	123 in.	123 in.
Area	3277 sq. in.	4920 sq. in.
Number of steps	Five	Five
Drive	V-belt	V-belt
Bearings	Oil soaked maple	Oil soaked maple
Extension pans	One on each walker	One on each walker
GRAIN TANK		
Capacity	65 bushels	80 bushels
WEIGHTS		
Combine with 12 ft. pickup platform	6200 lbs. (approx.)	7100 lbs. (approx.)
COMBINE DIMENSIONS		
Shipping length	23 ft.	23 ft.
Shipping width	10 ft. 2-1/2 in.	10 ft. 9-1/2 in.
For other dimensions	See page 4.	See page 4.

(Specifications and design are subject to change without notice.)

4 Specifications

The dimensions on the following charts are the same for both the 65 and 96 Combines except where indicated.

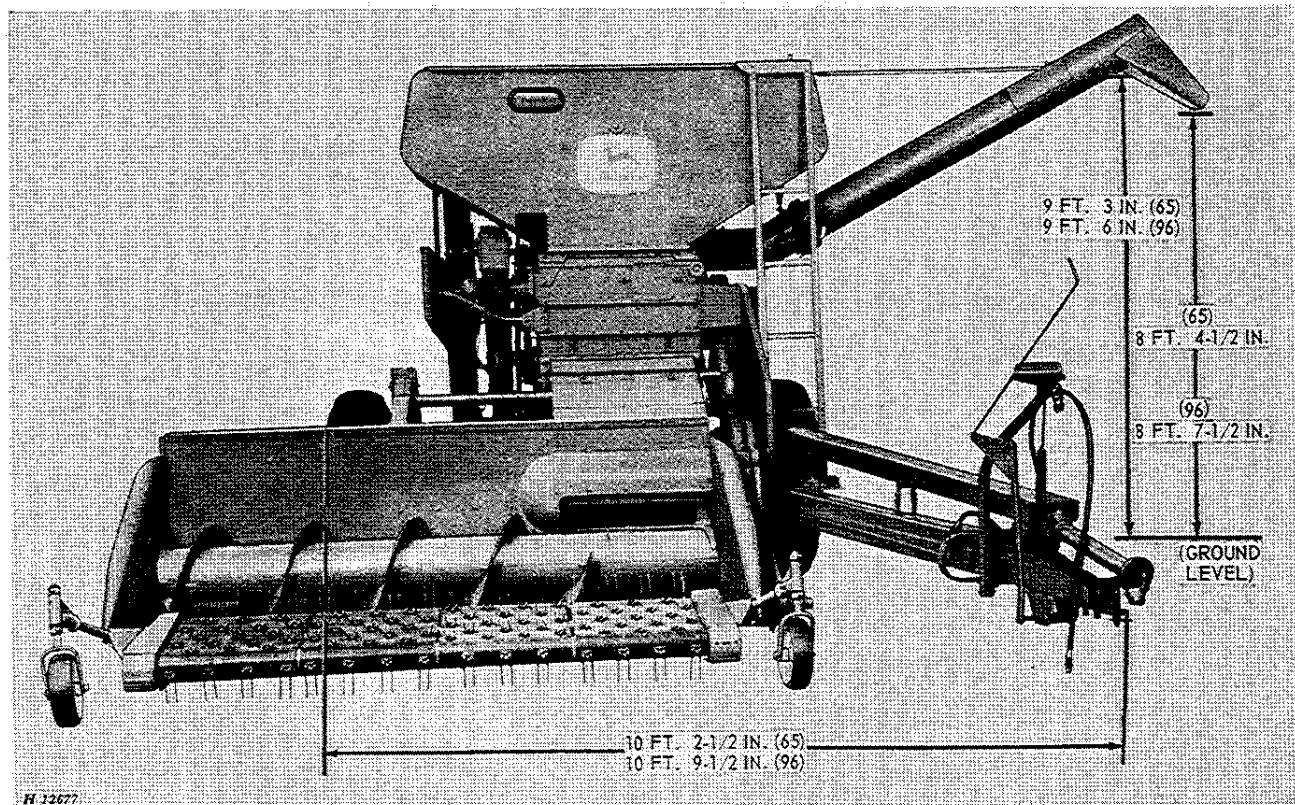
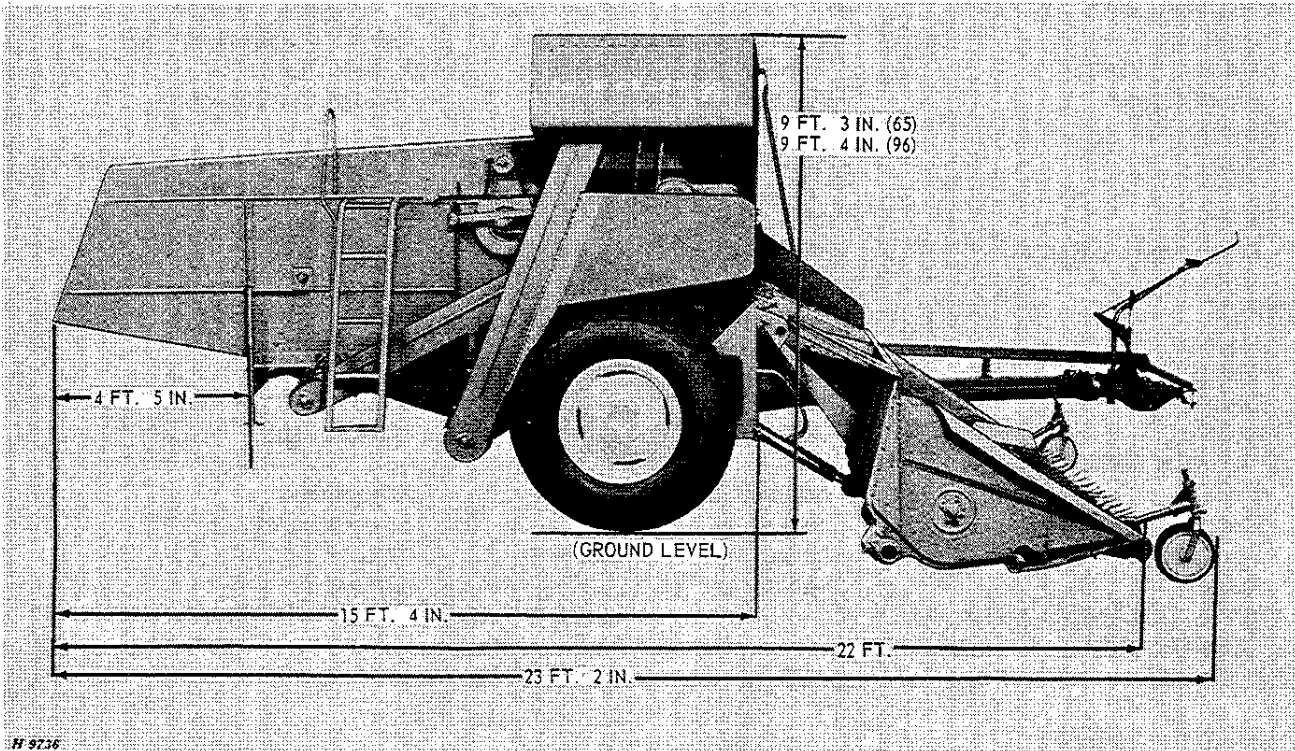



CONTROLS AND INSTRUMENTS

Before attempting to operate your new combine, become familiar with the location and purpose of its controls and instruments. Study these pages carefully, regardless of your previous combine experience.

GRAIN TANK UNLOADING LEVER

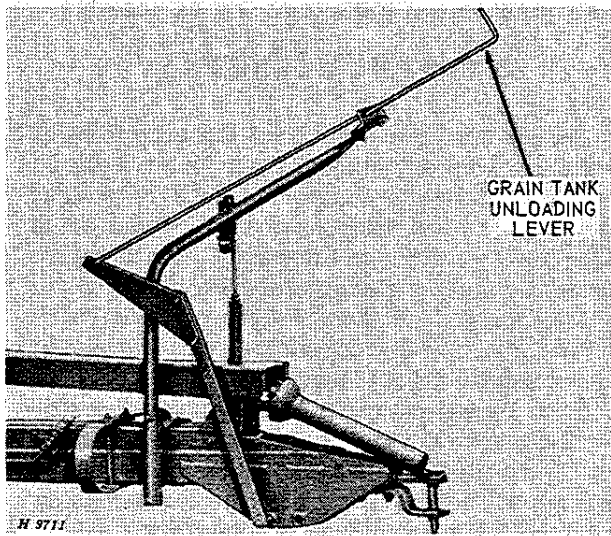

Push lever rearward to engage grain tank unloading auger. Pull lever forward to disengage it.

PLATFORM THROW-OUT SWITCH

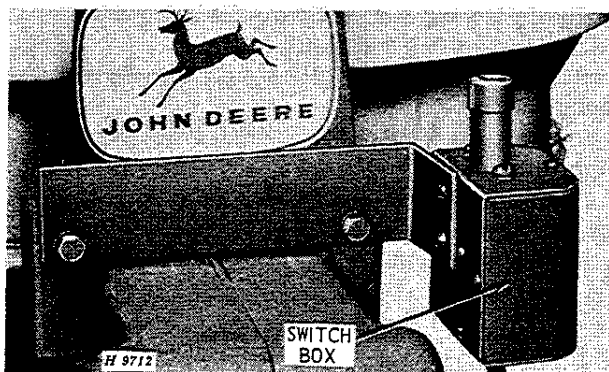

This switch operates the electromagnetic throw-out clutch which permits stopping the platform and feeder while the separator continues to run.

ADJUSTABLE PARKING STAND (SPECIAL ATTACHMENT)

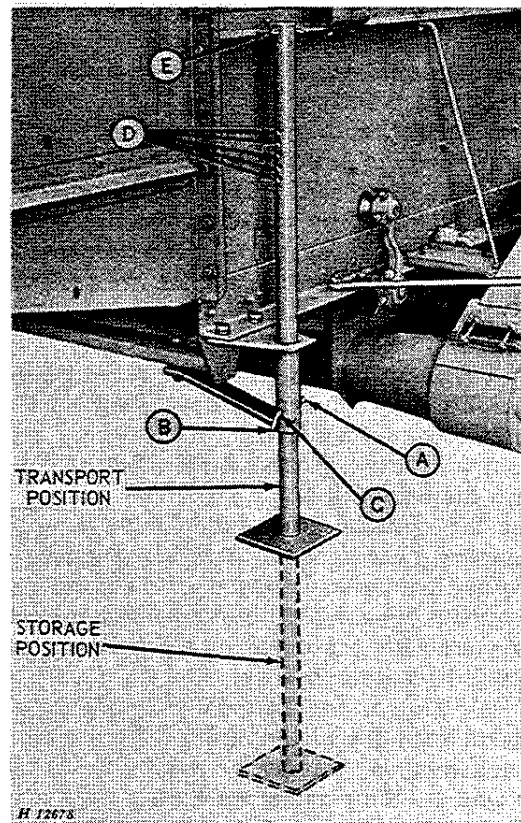

If your combine is equipped with the adjustable parking stand, lower stand to storage position before starting assembly procedure.

When combine is to be removed from the tractor for parking or storage purposes, remove pins "A" and "B," lower stand and insert pin "B" through hole "D." Secure lock pin with spring locking pin "A."

When combine is to be operated in the field, remove spring locking pin "A" and lock pin "B"; raise parking stand until lock pin "B" can be inserted into hole "C." Secure lock pin with spring locking pin "A."



OPERATION

FUNDAMENTALS OF COMBINE HARVESTING

The one most important factor in harvesting is for the operator to have a thorough understanding of the fundamentals of combine operation. The following pages contain information about speeds, settings and special equipment that will enable the operator to place these fundamentals into practice.

These fundamentals in brief are:

Be sure crop is in condition to thresh—moisture content not too high—straw not too green.

In making the first round of the field, keep the tractor forward speed as slow as possible to reduce the volume of material entering the combine. Always run the tractor at rated PTO speed to keep the combine mechanism up to full speed, thus guarding against slugging and clogging. Shift to a lower gear if necessary—but do not throttle down the engine.

Select a tractor ground speed that will not overload the combine.

Keep the cylinder speed as low as possible and concave clearance as high as possible to remove the maximum amount of grain from grain heads without breaking up the straw excessively. Maintain correct beater speed to guard against wrapping of straw on beater.

Cut the crop as high as possible without excessive loss of low grain heads. If the crop is down and tangled, it may be desirable to use lifting guards. Slow travel speed is imperative.

Adjust the reel position and speed for even feeding.

Regulate adjustable chaffer openings to pass the grain or seed to the lower sieve before it has passed over two-thirds the length of chaffer without admitting too much coarse material.

Close adjustable sieve as far as possible without carrying clean grain into the tailings auger.

If material loads up on front of chaffer, adjust upper windboard to throw air blast to front of shoe.

Use as much air blast as possible without blowing over clean seed. If the grain or seed is unusually light, it may be necessary to reduce the volume of air. In heavy seeds, increase the volume of air.

Keep amount of tailings as low as possible.

OPERATING SUGGESTIONS

Don't start combining until the crop is ripe.

Unless crop drying equipment is available, a crop should not be combined until it is dead ripe. If the threshed grain feels damp or is easily dented with the fingernail, the moisture content is usually too high for safe storage.

Grain crops containing 14 per cent moisture or less are usually considered dry enough for safe storage. A John Deere Moisture Meter for checking moisture content of grain and a portable Grain Dryer can be purchased from your John Deere dealer, or arrangements can usually be made at the local grain elevator for necessary moisture tests and drying if necessary.

OPERATION IN WEEDY CONDITIONS

Combining in fields where weeds are numerous is particularly troublesome as they tend to gum up the sieves. Also, the moisture in the seeds is imparted to the grain.

The following suggestions will help while operating in weedy conditions.

Cut the crop as high as possible to avoid weeds and undergrowth.

Check to see that the cylinder is operating at proper speed.

Use as much air blast on the shoe as possible without blowing over grain.

Lower rear end of chaffer.

HOLD DOWN THE GROUND SPEED

Excessive travel speed is one of the greatest causes of trouble in combining. Traveling at too high a ground speed causes overloading, resulting in a loss of grain.

Also, traveling at an excessively high speed over rough ground also causes extra wear and damage to parts, not incurred when the combine is operated at a more reasonable speed.

KEEP STEADY, SMOOTH TRACTOR ENGINE SPEED

Any fluctuation in engine speed is reflected in the speed of the separator. Uneven speed results in loss of grain, inferior threshing and, in extreme cases, complete plugging of the combine. Take every precaution to maintain the correct uniform speed.

By rounding the corners in the field, you can maintain more uniform speed when turning.

When stopping, wait until material in the combine is cleaned out before disengaging tractor PTO lever.

BEFORE-OPERATION CHECKS AND ADJUSTMENTS

Careful inspection and service of the combine before starting work each day will prevent needless delays and breakdown in the field. Make the following checks and adjustments:

Lubricate the combine completely. See Lubrication section, page 15.

Open the doors at bottom of elevators and leave them open until combine is started.

Inspect belts and chains for proper tension and alignment. See that there are no loose bolts or missing cotter pins.

COMBINE BREAK-IN

Check all V-belt drives carefully for proper alignment and tension. Keep belts tight enough to prevent slippage. Belts can be ruined very quickly if allowed to slip in the grooves of a sheave for any length of time. Excessive heating of a sheave is a sign of belt slippage. New belts will stretch slightly after the first run-off. Check tension frequently.

Open the clean-out doors in the bottom of the clean grain and tailings elevators and check tension of elevator chains—see page 39 for adjustments. It is a good plan to check the chain tension every day of operation.

Be certain all shafts turn freely.

STARTING THE COMBINE

Make certain no one is standing near enough to the combine or tractor to touch any moving parts. Warn everyone to stand clear.

When tractor is properly warmed up, push tractor PTO lever forward to engage the separator. Always run tractor at rated PTO speed.

Check the speed of beater behind the cylinder with a speed indicator. Beater should operate at 680 to 715 rpm with separator empty and not under load. If beater speed is not correct, check tractor PTO for correct rpm rated speed. If PTO is not operating at proper rpm rated speed see your John Deere dealer.

Test operation of hydraulic control for adjusting platform height.

Test operation of grain tank unloading auger.

Inspect entire combine again, making certain all units are working properly.

Disengage separator, then close doors at bottom of elevators.

8 Operation

SUGGESTED SETTINGS FOR COMBINING VARIOUS CROPS

(These suggested settings are for average conditions. Different field conditions may make it necessary to change these settings.)

Crop	Cylinder Range* (rpm)	Cylinder to Concave Clearance		Type of Cleaning Sieve	Setting of Adjustable Cleaning Sieve	Setting of Adjustable Chaffer	Setting of Adjustable Cleaning Fan Sheave (rpm)	Fan Side Shutter Opening
		Front	Rear					
Alfalfa	793 to 1190	3/16"	1/8"	Adjustable or 1/10" round hole	Slightly open	1/8 open	600-640	Closed
Barley— Feed and Malting	765 to 1190	1/2"	1/4"	Adjustable	1/3 to 1/2 open	1/2 to 1/3 open	780-850	Open
Beans— Baby Lima	277 to 425	3/4"	1/2"	Adjustable	Slightly over 1/2 open	2/3 to nearly wide open	840-850	Open
Beans— Soy	466 to 656	1/2"	1/4"	Adjustable or 3/8" round hole	1/2 open	2/3 open	810-850	Open
Beans— White Pea	466 to 656	1/2"	1/4"	Adjustable	1/2 open	2/3 open	810-850	Open
Buck Wheat	656 to 793	1/2"	3/16"	Adjustable	1/4 to 1/3 open	2/3 open	630-690	2/3 open
Clover— Most Varieties	893 to 1190	3/16"	1/8"	Adjustable or 1/10" round hole	Slightly open	1/4 open	600-640	Closed
Crotalaria	765 to 1190	5/32"	1/16"	Adjustable or 5/32" round hole	1/3 open	2/3 open	600-640	1/3 open
Flax	765 to 1190	1/4"	1/8"	Adjustable or 5/32" round hole	1/3 open	1/3 to 1/2 open	600-640	1/3 open
Grass— Blue	893 to 1190	3/16"	1/8"	Adjustable or 5/32" round hole	1/4 to 1/3 open	1/2 to 2/3 open	600-640	Closed
Lespedeza	656 to 952	3/16"	1/8"	Adjustable or 5/32" round hole	1/3 open	1/2 to 2/3 open	620-660	1/3 open
Lupine	500 to 574	3/8"	1/4"	Adjustable	1/2 open	2/3 open	700-740	1/2 open
Maize	765 to 893	5/16"	3/16"	Adjustable	1/4 to 1/2 open	2/3 open	790-850	Open

*See page 32 for various sprocket combinations.

Crop	Cylinder Range* (rpm)	Cylinder to Concave Clearance		Type of Cleaning Sieve	Setting of Adjustable Cleaning Sieve	Setting of Adjustable Chaffer	Setting of Adjustable Cleaning Fan Sheave (rpm)	Fan Side Shutter Opening
		Front	Rear					
Mustard	765 to 1190	3/8"	1/4"	Adjustable	1/4 to 1/3 open	2/3 open	710-760	Closed
Oats	765 to 1190	5/16"	3/16"	Adjustable	1/3 to 1/2 open	3/4 open	760-810	Open
Peas—Field	388 to 540	1"	3/4"	Adjustable	1/3 open	2/3 open	790-840	Open
Proso or Hog Millet	793 to 952	3/16"	1/8"	Adjustable or 5/32" round hole	Slightly open	1/2 open	740-800	Open
Radish Seed	656 to 893	3/16"	1/8"	Adjustable or 5/32" round hole	Closed to 1/4 open	1/3 to 1/2 open	610-640	Closed
Rye	893 to 1190	5/16"	1/4"	Adjustable	1/3 open	2/3 open	790-820	Open
Safflower	756 to 793	1/2"	3/16"	Adjustable	1/2 open	3/4 open	760-830	Open
Sorghums	793 to 952	1/2"	1/8"	Adjustable	1/4 to 1/2 open	2/3 to 3/4 open	785-840	Open
Timothy	952 to 1190	5/32"	1/16"	Adjustable or 1/10" round hole	Slightly open	1/2 open	610-700	Closed
Trefoil, Bird's—Foot	952 to 1190	5/32"	1/16"	Adjustable or 1/10" round hole	Slightly open	1/4 open	600-655	Closed
Wheat	952 to 1190	5/16"	3/16"	Adjustable	1/3 to 1/2 open	2/3 open	790-845	Open

SPEED OF VARIOUS UNITS

(RATED PTO SPEED)

Auger, Platform (65)	245 rpm	Fan (Extreme Low)	602 rpm
	(96) 250 rpm	Fan (Extreme High)	858 rpm
Beater Behind Cylinder	680 to 715 rpm	Feeder House Conveyor Drive	
Cylinder:		Shaft (65)	225 rpm
Regular	1057 rpm		(96) 231 rpm
Cylinder (Extreme Low)	196 rpm	Grain Conveyor Under Cylinder:	
Cylinder (Extreme High)	1190 rpm	(With Regular 15-Tooth Sprocket).	170 rpm
Elevators	313 rpm	Reel (65)	28.1 to 36.1 rpm
Fan (Normal Operating Speed)	750 rpm		(96) 28.6 to 36.8 rpm
		Shoe Crank	286 rpm
		Straw Walker	213 rpm

TRACTOR HOOKUP

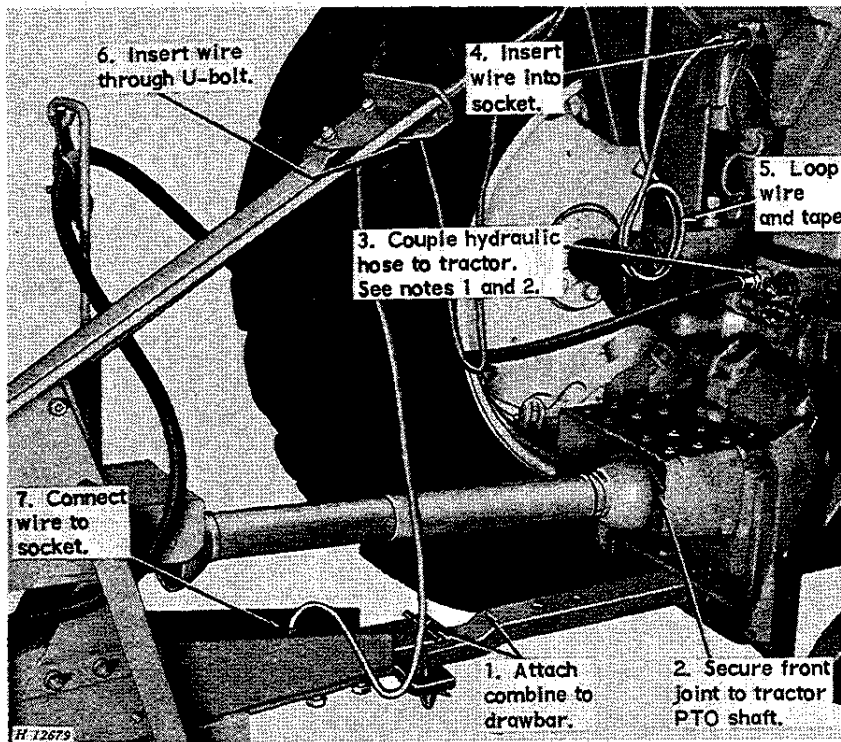

NOTE 1: Adapt the tractor remote hydraulic cylinder valve housing for single-action cylinder operation. See tractor operator's manual. Couple hydraulic hose to tractor No. 1 hydraulic circuit breakaway coupler.

NOTE 2: On John Deere 820 and 830 Tractors equipped with dual valve equipment, it will be necessary to install conversion kit No. AR21261R for single action cylinder operation.

IMPORTANT: All 96 Combines with 1000 rpm PTO drives must be connected to tractors with like power source such as John Deere Models 4010, 4020, 5010, and 5020 Tractors, or other tractors of comparable power source. Combines with 540 rpm PTO drives must be connected to tractors such as John Deere Models 80, 820, 830 and "R" Tractors or other tractors of comparable Power Source.

1000 RPM YOKE ASSEMBLY

Should it become necessary to disturb locking clamp on hitch tube powershaft, make certain bearing and yoke assemblies are assembled on the shaft, using dimensions given in the illustration at the right for proper position. Failure to do so will cause misalignment of hookup parts.

IMPORTANT: Under normal circumstances, locking clamp should not be moved; only when it becomes necessary to make replacement of parts.

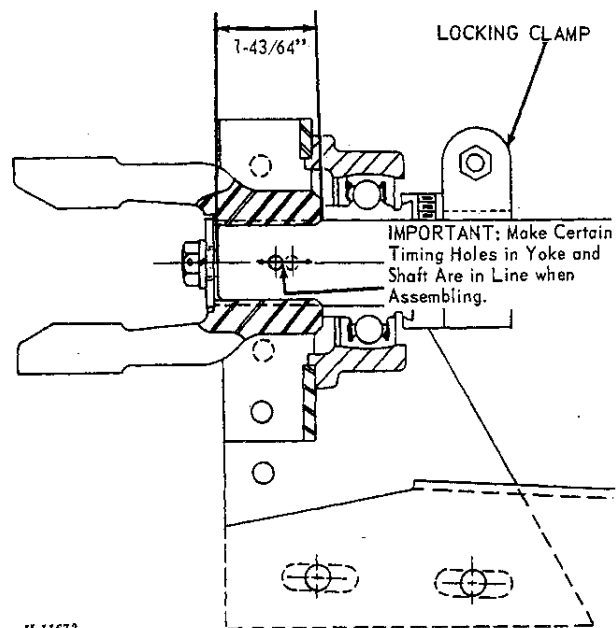

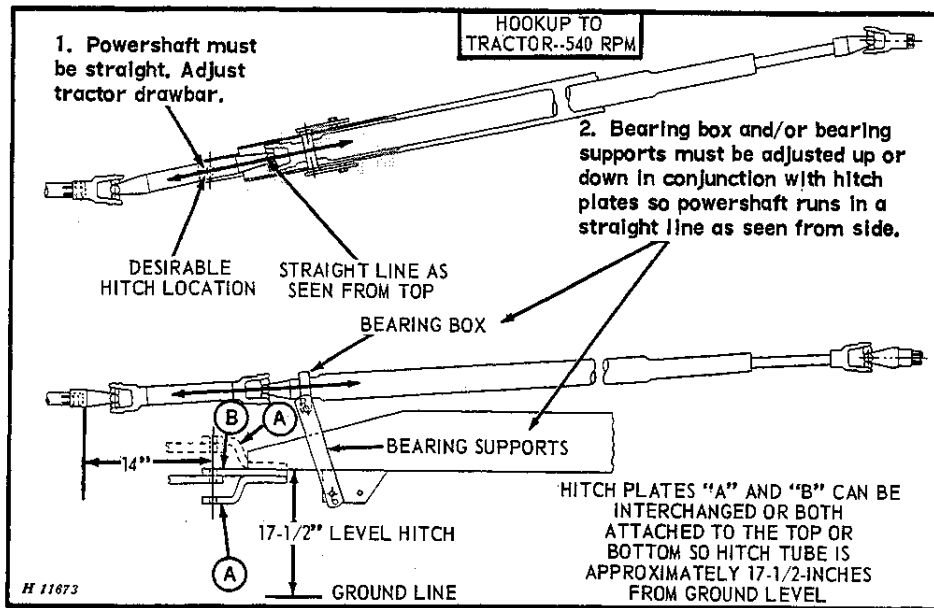

Hookup to Tractor-540 rpm

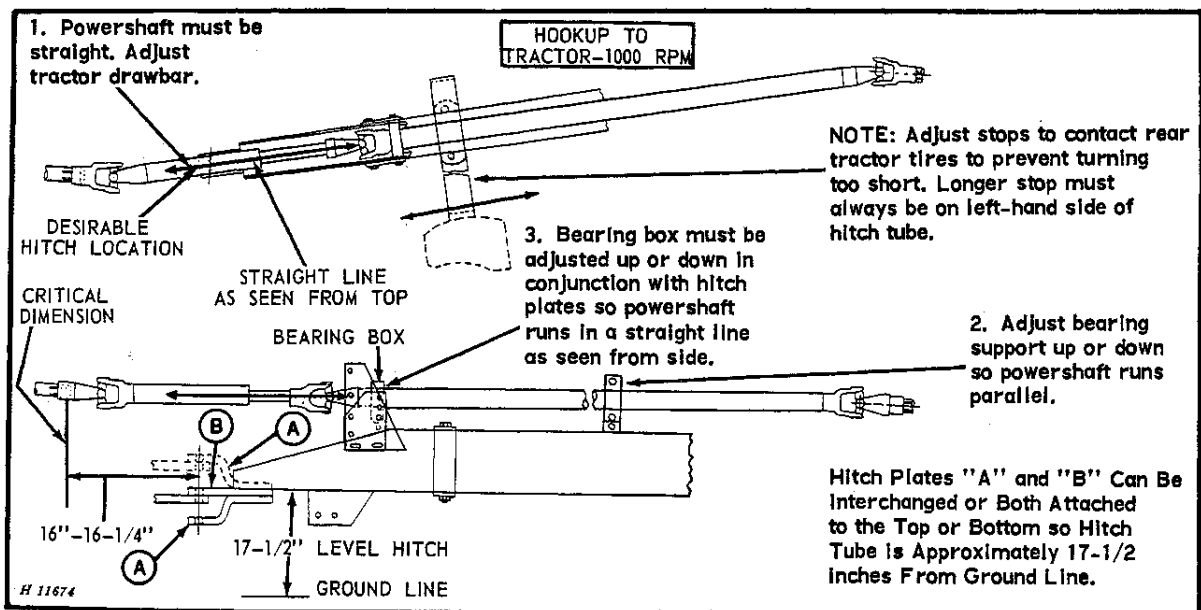

Hookup to Tractor-1000 rpm

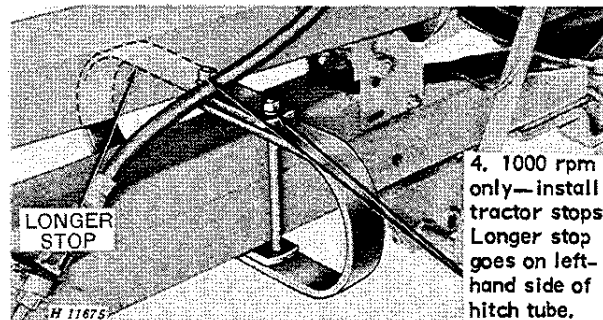

ATTACHING CUTTING PLATFORM

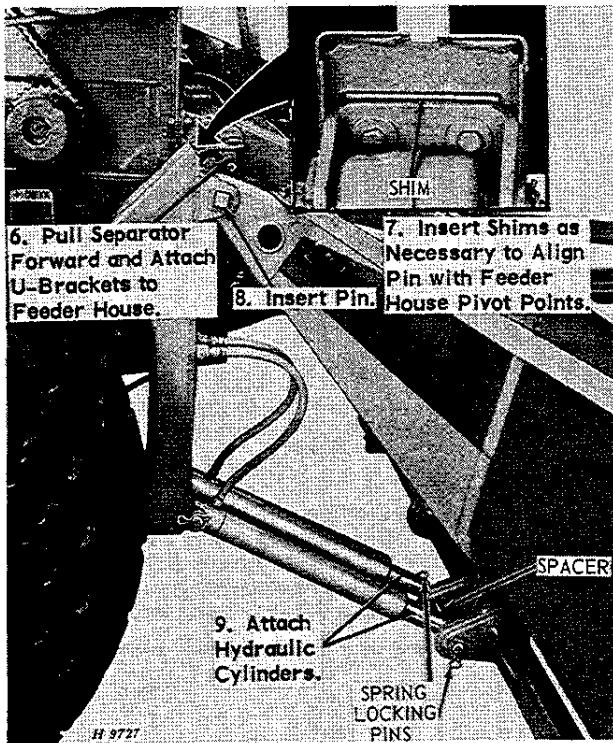
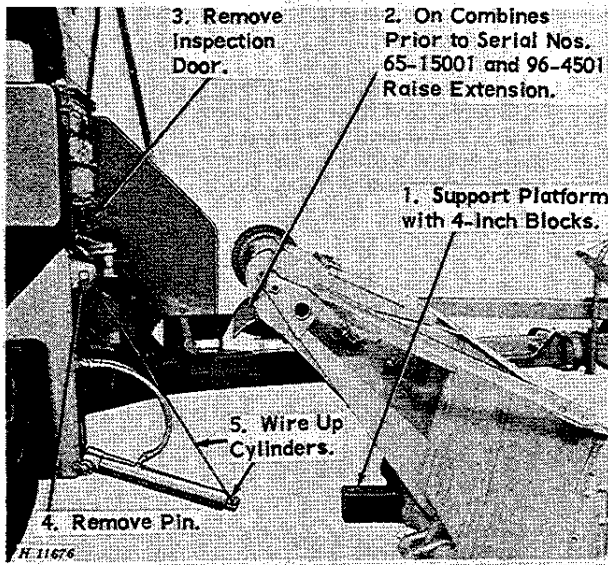

TRANSPORTING

This combine is designed for easy and safe transporting. The width of the combine can be reduced by folding unloading auger back along separator, and removing cutting platform.

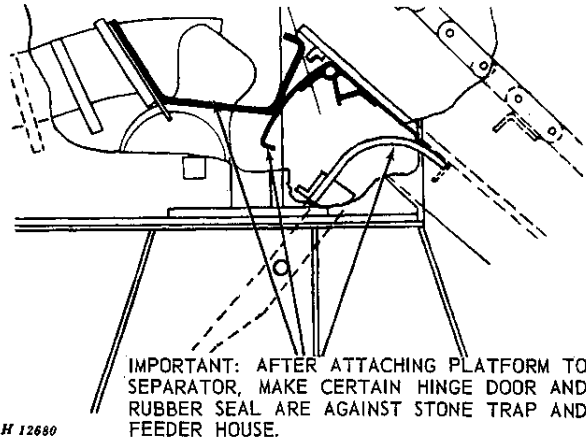

To fold unloading auger back along separator, unfasten over-center lock and swing outer half of auger back. Secure outer end of auger against separator with transport lock.

IMPORTANT: Disconnect powershaft from tractor when transporting.

CAUTION: When transporting the combine on a road or highway at night or during the day, use accessory lights and devices for adequate warning to the operators of other vehicles. In this regard, check your local governmental regulations. Various safety lights and devices are available at your John Deere dealer.

Reflective tape (special attachment)

- JD134B Red reflective tape (order two)
- JD138B Silver reflective tape

To apply tape, peel off backing from gummed side of tape and press tape firmly onto combine surface.

CAUTION: Apply tape only to clean, wax-free surfaces at moderate temperatures. Peel off black covering on front of the tape.



Suggest:

If the above button click is invalid.

Please download this document

first, and then click the above link

to download the complete manual.

Thank you so much for reading

END OF THE SEASON SERVICE

If possible, store combine in a dry place.

Clean combine thoroughly inside and out. Chaff and dirt will draw moisture and rust the steel.

Remove and clean belts. Wrap them in burlap, and store in a cool, dark place. Clean chains and brush with heavy oil to prevent corrosion.

Clean out augers and elevators. Leave doors open at bottom of elevators.

Clean out bottom of grain tank and unloading auger. Open clean-out door.

Clean the chaffer and sieve.

Grease feeder house conveyor bottom to prevent rust.

Lubricate combine completely. Grease threads on bolts used for adjustments. Apply a coating of grease to slip clutch jaws.

Paint all parts from which paint was worn.

Use blocks to keep cutting platform level.

Block up combine, taking load off tires. Do not deflate tires. If combine is stored outside, remove wheels and tires and store in a cool, dark, dry place.

Release spring tension on all slip clutches, except friction-type slip clutch on powershaft.

Place a few drops of SAE 10W oil on the four studs for the face plate of the platform throw-out clutch.

List the repairs that will be needed before the next season and order them early. Your John Deere dealer can give better service during the off season. Also, repair parts can be installed in your spare time—no delay at harvest time.

THE COMPLETE OBSERVANCE of one simple rule would prevent many thousand serious injuries each year. THAT RULE IS: "NEVER ATTEMPT TO CLEAN, OIL, OR ADJUST A MACHINE WHILE IT IS IN MOTION."

BEGINNING OF THE SEASON SERVICE

The combine must be taken out of storage and carefully checked before starting the harvest season. By making sure your combine is in tip-top shape, you can avoid costly breakdowns during the harvest season.

Replace wheels if they were removed and remove blocking.

Clean the combine thoroughly inside and out.

Install belts, making sure they have the proper tension.

Adjust chains to proper tension. Be sure to check chains in clean grain and tailings elevators.

Clean slip clutches. Be sure to put grease in bore of slip clutches after cleaning.

Adjust spring tension on slip clutches.

Close elevator doors and close grain tank unloading auger clean-out door.

Lubricate combine completely, then run combine at half-speed for about an hour. Check bearings for overheating or excessive looseness. Be sure slip clutches operate freely.

Check tire inflation.

Go over complete combine and see that all bolts are tight and cotter pins are in place.

Review your operator's manual.



<https://www.ebooklibonline.com>

Hello dear friend!

Thank you very much for reading.

Enter the link into your browser.

The full manual is available for immediate download.

<https://www.ebooklibonline.com>