

55 COMBINE



JOHN DEERE

OPERATORS MANUAL

55 COMBINE

OMH131158 K8 English

OMH131158 K8

LITHO IN THE U.S.A.
ENGLISH

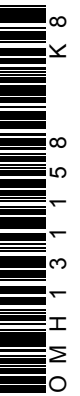

TO THE PURCHASER

The combine you have just purchased was designed and built to the traditionally high quality standards of all John Deere Farm Equipment. Your combine has been thoroughly inspected and tested not only at the factory but at your dealer's by a trained John Deere Serviceman. We are confident that you will receive years of dependable, economical service from your John Deere Combine.

STUDY THIS MANUAL CAREFULLY AND KEEP IT HANDY IN A SAFE PLACE FOR FUTURE REFERENCE.

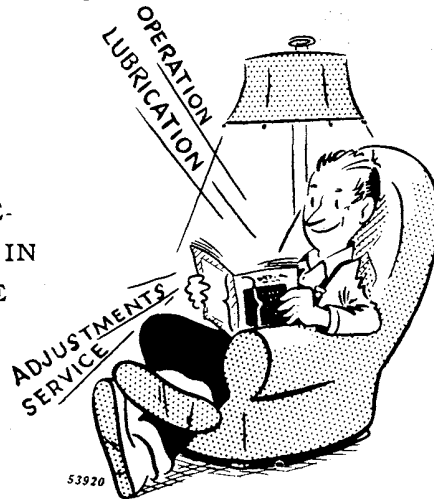

If you should find that you require information not covered in this manual, consult your John Deere dealer. He will be glad to answer any question that may arise regarding the operation and handling of the combine. He has trained mechanics who are kept informed on the best methods of John Deere Combine servicing and can give you prompt know-how service in the field or in his shop.



- Because the first thing **every day**, I
- √ Lubricated the combine properly.
 - √ Checked the water, oil, and fuel for the combine engine.
 - √ Made the proper adjustments for the crop and field conditions.

**THESE DAILY PRECAUTIONS
WILL INSURE GOOD PERFORMANCE
AND LONG SERVICE**

LOCATION REFERENCE

“Right-hand” and “left-hand” sides are determined by facing in the direction the combine will travel when in use.

“Clockwise” refers to parts turning to the right like the hands of a clock. “Counter-clockwise” refers to parts turning to the left.

Engine Reference Only. Timing gear end of engine is referred to as the “front,” flywheel end as the “rear.”

KEEP YOUR COMBINE A JOHN DEERE COMBINE

Genuine John Deere Parts are made to fit properly and insure satisfactory service because they are made from the original patterns and from the same materials as used in new machines. Should your combine require replacement parts, go to your John Deere dealer where you can obtain Genuine John Deere Parts—accept no substitutes.

SERIAL NUMBERS

The separator, engine, axle, and cutting platform have serial numbers.

When ordering parts, refer to the model and serial number. By doing so, you will assist your John Deere dealer in giving you prompt, efficient service.

Record the serial numbers in the spaces provided below. It is a good plan to copy the serial numbers down on a card to be carried in your bill-fold for quick reference.

The separator serial number is stamped on a plate located on the support bracket for the rear end of the fuel tank.

The engine serial number is stamped on a plate located on top of the flywheel housing.

The axle serial number is stamped on the top, left-hand end of the axle tube.

The cutting platform serial number is stamped on a plate located on the right-hand side of the cutting platform.

Separator Serial No.
 Engine Serial No.
 Axle Serial No.
 Cutting Platform Serial No.
 Date Purchased.

<https://www.ebooklibonline.com>

Hello dear friend!

Thank you very much for reading.

Enter the link into your browser.

The full manual is available for immediate download.

<https://www.ebooklibonline.com>

TABLE OF CONTENTS

	<i>Page</i>
SERIAL NUMBERS.....	1
GENERAL VIEWS.....	4
SPECIFICATIONS.....	7
LUBRICATION.....	13
OPERATOR'S PLATFORM HINGED LADDER.....	36
COMBINE CONTROLS.....	41
OPERATOR'S SEAT.....	41
OPERATION.....	42-76
Breaking in the New Combine.....	42
Engine Break-In.....	42
Before Operation Checks and Adjustments.....	43
Starting the Engine.....	43
Stopping the Engine.....	44
Starting the Combine.....	44
Selecting Proper Ground Speed.....	44
Drive Wheel Tread.....	45
Speed of Various Units.....	46
Cutting Platform Height.....	46
Basic Settings Made at the Factory.....	46
Electro-Magnetic Throw-Out Clutch for Platform.....	48
Cross-Sectional View of the 55 Combine.....	50
Fundamentals of Combine Harvesting.....	52
Operating Suggestions.....	53
Corn Combining Suggestions.....	56
Suggested Settings for Combining Various Crops.....	62
Slip Clutches.....	68
Safety Suggestions.....	70
Transporting.....	72
Highway Safety Lighting.....	73
Cold Weather Operation.....	74
Care When the Season Is Over.....	75
Care at the Beginning of the Next Season.....	76
ADJUSTMENTS AND SERVICE.....	77-166
Inspection Doors.....	77

TABLE OF CONTENTS—Continued

	<i>Page</i>
Reel.....	78
Cutter Bar.....	85
Cutting Platform Auger.....	89
Feeder Conveyor.....	92
Cutting Platform Leveling Adjustment.....	95
Cutting Platform Height Range Adjustment.....	96
Cutting Platform Special Equipment.....	97
Cylinder and Concave Grate.....	101
Feed Rolls Attachment.....	118
Cleaning Fan.....	119
Chaffer and Sieve.....	123
ScourKleen.....	127
Shoe Pitman.....	130
Grain Conveyor.....	131
Straw Walkers.....	132
Clean Grain and Tailings Elevators.....	133
Straw Chopper.....	137
Straw Spreader.....	138
Selective Ground Speed Control.....	139
Separator Throw-Out Lever.....	141
Grain Tank Unloading Auger.....	143
Clutch.....	144
Brakes.....	145
Transmission.....	146
Steering Mechanism.....	147
Hydraulic System.....	152
Toe-In Adjustment.....	153
Care of Chains and V-Belts.....	154
Care of Tracks.....	158
Care of Rubber Tires.....	160
Service Chart.....	161
ENGINE SERVICE.....	167-185
Fuel System.....	167
Carburetor.....	168
Governor.....	170
Wiring Diagram.....	171
Ignition System.....	172
Starting System.....	174
Cooling System.....	178
Valve Tappet Adjustment.....	181
Engine Removal.....	181
Service Chart.....	182
INDEX.....	186

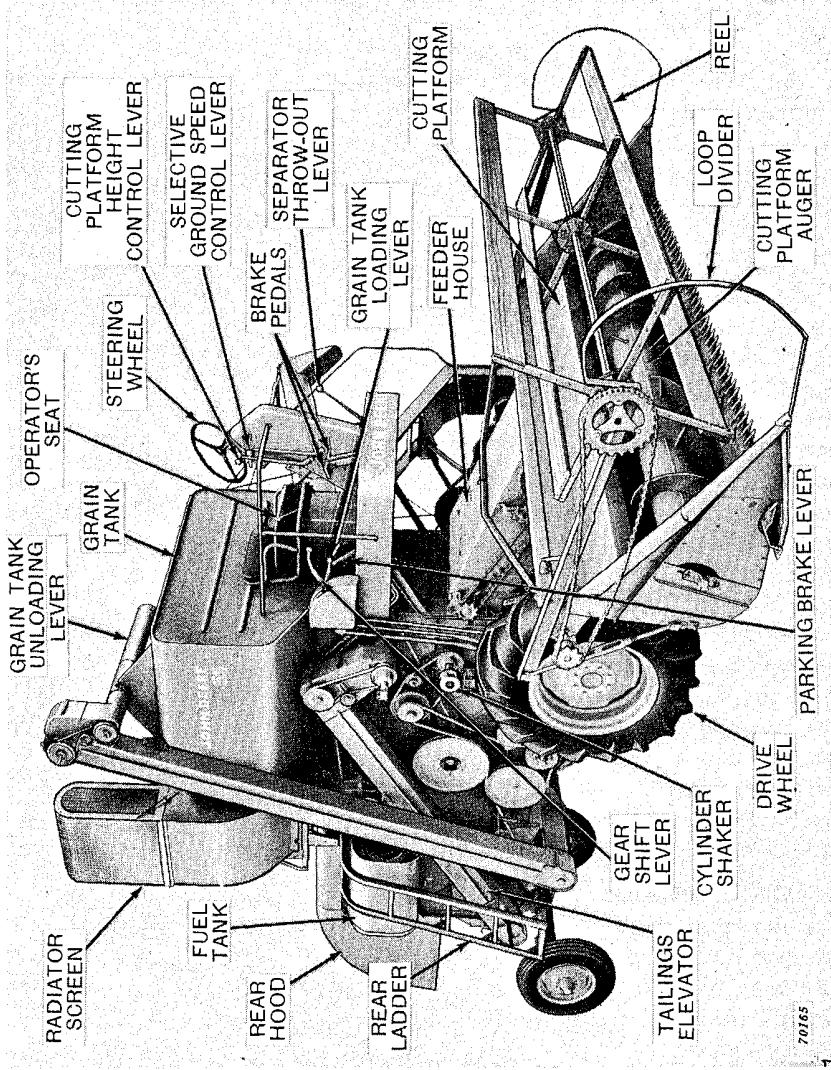

Right-Hand Complete View of John Deere 55 Self-Propelled Combine (with Grain Tank)

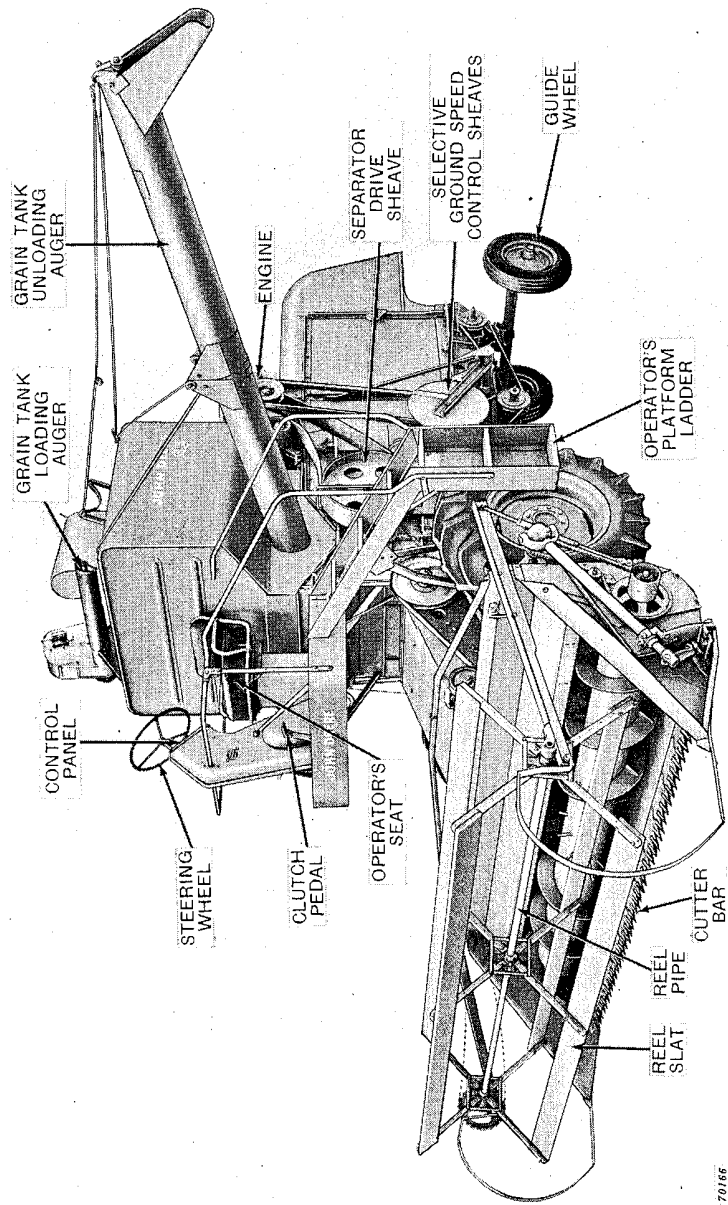

70165

Left-Hand Complete View of John Deere 55 Self-Propelled Combine (with Grain Tank)

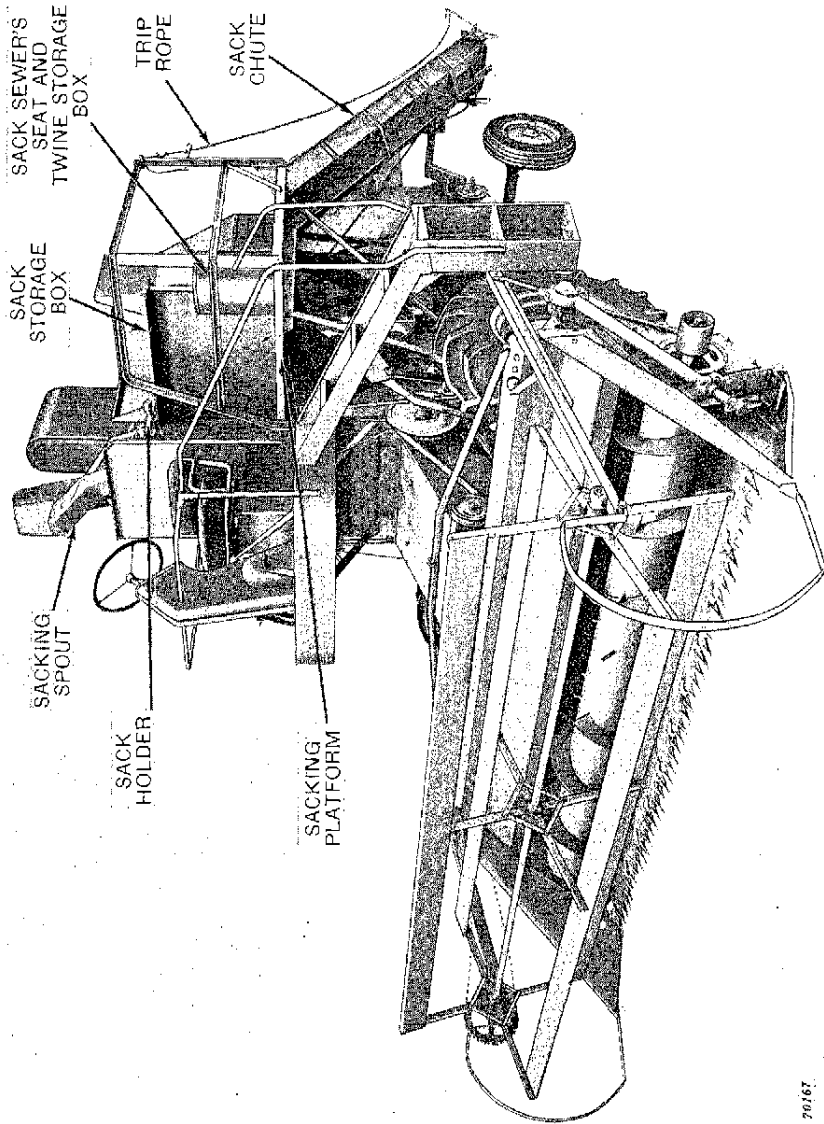

70167

Left-Hand Complete View of John Deere 55 Self-Propelled Combine (with Sacking Attachment)

SPECIFICATIONS

COMBINE

Cutter Bar

Width of Cut... 12-Ft. or 14-Ft.
 Length of Cutter Bar... 11-Ft. 6-In. or 13-Ft. 6-In.

Type of Knife

Sections... Heavy-Duty Over-serrated

Reel

Speed Range... 18.5 to 44.2 rpm
 Drive... Chain
 No. of Bats... 3, 4, 6, or 8
 Dia. of Reel... 31-3/8-In. or 42-In.

Cutting Platform

Type... Auger
 Hinged or Rigid... Hinged
 Range of Cutting Height (Grain) 2-1/2-In. to 35-In.
 Range of Cutting Height (Rice) 2-1/2-In. to 38-In.
 Control... Hydraulic (2 Rams)

Platform Auger

Diameter... 18-In.
 Diameter of Auger Tube... 10-In.
 Type of Auger Fingers... Round Retracting

Cylinder

Type... Rasp-Bar or Spike-Tooth
 Width... 30 Inches
 Diameter... 22 Inches
 Speed... 196 to 1190 rpm
 Drive... Roller Chain

Concave

Type... 12-Bar Open-Type or Spike-Tooth Type

Beater

Type... Wing or Drum
 Width... 30 Inches
 Speed... 680 to 685 rpm
 Drive... Belt (Flat)

Separator

Type... 3 Straw Walker
 Width... 30 Inches
 Length... 10 Ft. 10 In.

Grain Conveyor

Type... Slat
 Drive... Chain

Fan

Type... 5-Bladed Undershot
 Speed Range... 540 to 680 rpm (550 to 810 rpm with Special Sheave)
 Drive... V-Belt

Chaffer

Type... Adjustable
 Width... 28-1/2 Inches
 Length... 48 Inches

Sieve

Type... Adjustable
 Width... 28-1/2 Inches
 Length... 45 Inches

Straw Walkers

Number... Three
 Length... 105 Inches
 Width... 9-1/2-Inches
 Drive... V-Belt
 Speed... 208 rpm
 Bearings... Oil Soaked Maple
 Extension Pans... One on Each Walker

Grain Tank

Capacity... 55-Bushel
 Type of Unloading... Rigid or Hinged Unloading Auger (Optional)

Brakes

Type... Individual, Mechanical Disk-Type

COMBINE—Continued

WEIGHTS

Grain Combine with 12-Foot Cutting Platform	8,129 Lbs. (Approx.)
Sacker Combine with 12-Foot Cutting Platform	8,061 Lbs. (Approx.)
Rice Combine with 12-Foot-Cutting Platform	9,064 Lbs. (Approx.)

TIRE SIZES

Drive Wheels		Rear Wheels	
(Grain)	13-26 Cleat	(Grain and Bean)	6.00-16 Rib Implement
(Grain)	13-26 Low Profile		
(Grain)	14-26 Low Profile	(Grain)	6.50-16 Rib Implement
(Grain)	14-26 Cleat		
(Grain)	14-26 Low Profile	(Grain)	7.50-16 Rib Implement
(Grain)	15-26 Low Profile (16" Rims)		
(Grain)	15-26 Cleat	(Grain, Bean, and Rice)	7.50-18 Skid Ring
(Grain and Bean)	15-26 Rice (16" Rims)		
(Rice)	18-26 Rice (16" Rims)	(Rice)	7.50-20 Rib Implement
(Rice)	18-26 Rice (20" Rims)		
(Rice Crawler) . .	16" Tracks	(Rice Crawler)	7.50-20 Rib Implement

DRIVE WHEEL TREAD

Combine	Drive Wheel Position	Tire Size	Spacers	c/c Drive Wheel Tread
55 Grain	Dished In	13-26	No	76 Inches
55 Grain	Dished Out	13-26	No	89-13/16 Inches
55 Bean	Dished In	15-26 on 16" Rim	Yes	82 Inches
55 Bean	Dished In	15-26 on 16" Rim	No	73 Inches
55 Bean	Dished Out	15-26 on 16" Rim	Yes	90 Inches
55 Bean	Dished Out	15-26 on 16" Rim	No	81 Inches
55 Rice	Dished Out	18-26 on 16" Rim	Yes	90 Inches
55 Rice	Dished Out	18-26 on 20" Rim	Yes	94 Inches
55 Rice Crawler	Tracks	...	114-11/16 Inches

TRANSMISSION

Type.....Automotive—4-Speeds Forward, 1 Reverse

SELECTIVE GROUND SPEED CONTROL RANGE

<p>13-26 TIRES—GRAIN DRIVE (Min.) (Max.)</p> <p>1st Gear..... .63 to 1.42 mph 2nd Gear..... 1.26 to 2.84 mph 3rd Gear..... 2.60 to 5.84 mph 4th Gear..... 5.20 to 11.70 mph Reverse..... 1.64 to 3.69 mph</p>	<p>14-26 TIRES—GRAIN DRIVE (Min.) (Max.)</p> <p>1st Gear..... .65 to 1.46 mph 2nd Gear..... 1.30 to 2.92 mph 3rd Gear..... 2.65 to 5.95 mph 4th Gear..... 5.30 to 11.90 mph Reverse..... 1.67 to 3.74 mph</p>
<p>15-26 TIRES—GRAIN DRIVE (Min.) (Max.)</p> <p>1st Gear..... .68 to 1.54 mph 2nd Gear..... 1.37 to 3.08 mph 3rd Gear..... 2.82 to 6.52 mph 4th Gear..... 5.64 to 12.70 mph Reverse..... 1.77 to 4.00 mph</p>	<p>15-26 TIRES—RICE DRIVE (Min.) (Max.)</p> <p>1st Gear..... .59 to 1.34 mph 2nd Gear..... 1.18 to 2.67 mph 3rd Gear..... 2.42 to 5.45 mph 4th Gear..... 4.83 to 10.08 mph Reverse..... 1.52 to 3.42 mph</p>
<p>18-26 TIRES—RICE DRIVE (Min.) (Max.)</p> <p>1st Gear..... .64 to 1.44 mph 2nd Gear..... 1.28 to 2.88 mph 3rd Gear..... 2.61 to 5.85 mph 4th Gear..... 5.22 to 11.72 mph Reverse..... 1.63 to 3.69 mph</p>	<p>TRACKS—GRAIN DRIVE (Min.) (Max.)</p> <p>1st Gear..... .35 to .81 mph 2nd Gear..... .72 to 1.62 mph 3rd Gear..... 1.46 to 3.29 mph 4th Gear..... 2.93 to 6.58 mph Reverse..... .92 to 2.07 mph</p>

Capacities (Approx.)

Fuel Tank..... 25 U.S. Gallons
Cooling System
(Radiator)..... 6 U.S. Gallons
Engine Crankcase 4 U.S. Quarts
Oil Filter..... 1 U.S. Quart

Air Cleaner..... 1 U.S. Quart
Hydraulic Unit (In-
cluding Hydraulic
Oil Lines and Cyl-
inders)..... 7 U.S. Quarts

DIMENSIONS—OVER-ALL

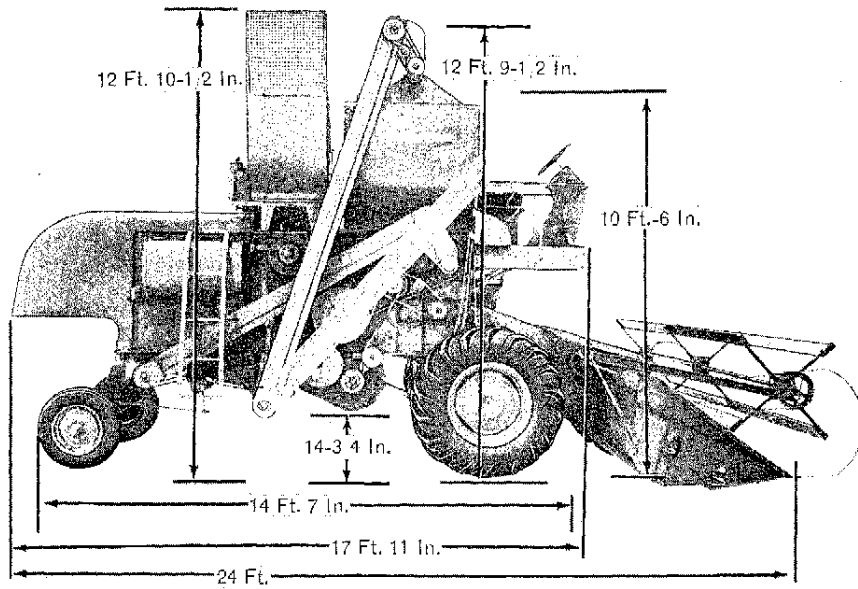

70168

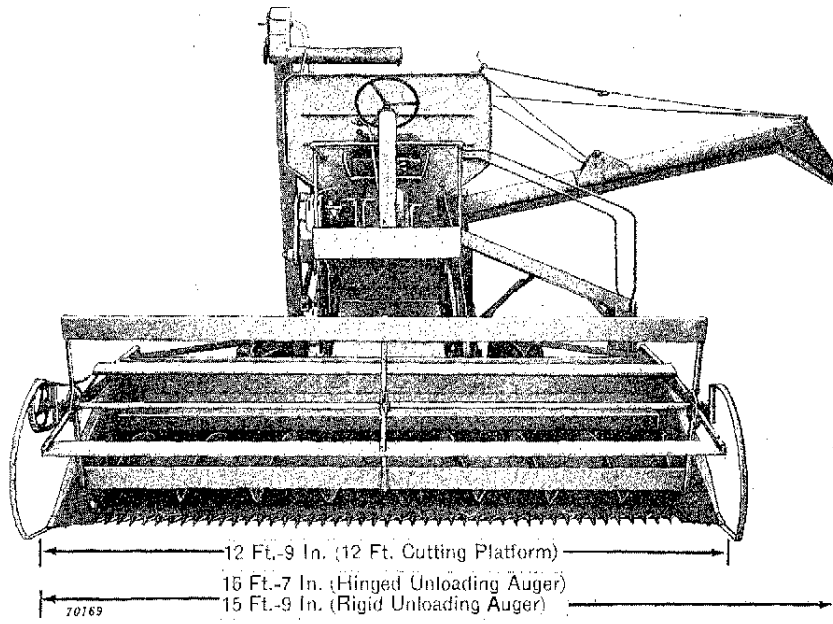

70169

DIMENSIONS—OVER-ALL

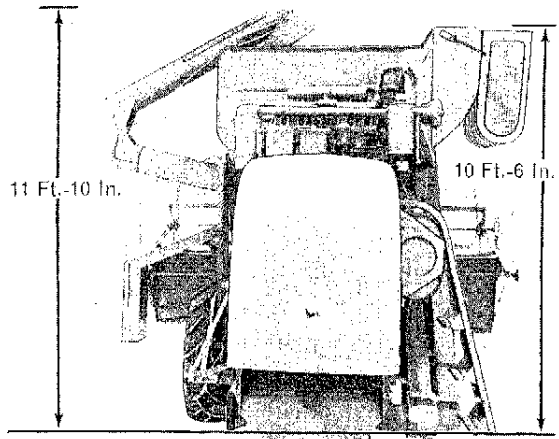

Ground Level

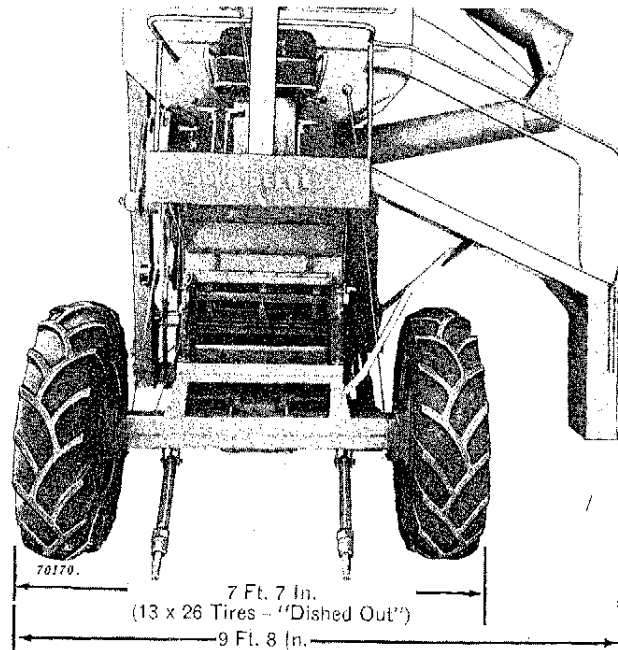
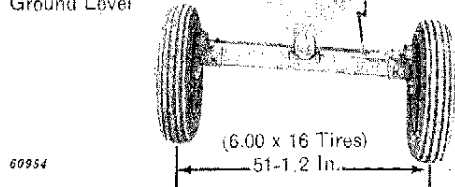

ENGINE

NOTE: For LP-Gas or Diesel Engine Specifications, see Operator's Manual furnished with LP-Gas or Diesel Combine.

Make of Engine.....	John Deere HA-217G (Gasoline)	Valve Arrangement.....	Valve-in-Head
Bore.....	3-5/8-In.	Valve Clearance Intake.....	.015-In. (When Cold)
Stroke.....	3-1/2-In.	Exhaust.....	.015-In. (When Cold)
Brake Horsepower.....	64	Make of Governor.....	John Deere
Number of Cylinders.....	6	Make of Carburetor.....	Marvel-Schebler
Piston Displacement.....	217 Cu. In.	Spark Plug....	Champion H-10 or Auto-Lite AL-7 or AC-45L, Gap .025-In., Heat Range 1200° to 1500° F.
Max. Load Speed.....	2200 rpm	Electrical System.....	12-Volt (Two 6-Volt Batteries)
Firing Order...	1-5-3-6-2-4	Type of Fuel...	Gasoline (Regular Grade)
Crankcase.....	Cast Integral with Block		
Type of Lubrication.....	Force Feed by Gear Pump to All Connecting Rods, Main Bearings, Governor, and Oil Pump Drive. Oil Strainer in Bottom of Pan.		

SPECIAL EQUIPMENT AVAILABLE

	<i>Page</i>		<i>Page</i>
Belt Pickup Attachment.....	98	Hillside Attachment for Shoe.....	127
Belt Wipers for Reel Slats....	81	Lifting Guards.....	88
Chaffer and Sieves, Special Types.....	125	Lighting Attachment.....	73
Chain Detacher.....	154	Mud Guard.....	136
Cleaning Fan Housing Protective Shield.....	58	Reel End Shields.....	84
Concave Cover Plates.....	114	Seat Arm Cushions.....	41
Corn Attachment.....	100	Steel Elevator Paddles.....	134
Cutter Bar Extension.....	87	Straw Chopper.....	137
Cutting Platform Support Stand.....	97	Straw Spreader.....	138
Cylinder Shear Hub Drive....	110	Stubble Shield.....	136
Elevator Special Connections.	134	Variable Drive Indicator Attachment.....	141
Feed Rolls Attachment.....	118	Weed Bar.....	98
Guard and Knife Repair Block	88	Weed Seed Cleaner (Hart ScourKleen).....	127
High Speed Fan Sheave.....	121		
Highway Safety Lighting Attachment.....	73		

(Specifications and design subject to change without notice.)

LUBRICATION

The economical and efficient operation of any machine depends on regular and proper lubrication of all moving parts with a quality lubricant. This is especially true of farm equipment which must operate in hot, dusty conditions over rough ground. Neglected lubrication quickly leads to reduced efficiency, heavy draft, wear, breakdown, and replacement of parts.

Use a clean container for storing and handling all lubricants. **See that only clean lubricants go into the working parts of your combine.**

LUBRICATION CHARTS

All lubrication points will be found in the lubrication charts that follow. The way the charts have been grouped organizes your lubrication work for you.

4 Hour Lubrication	Page 15
4 and 8 Hour Lubrication	Pages 16 and 17
4, 8, and 40 Hour Lubrication	Page 17
8 Hour Lubrication	Pages 18 to 22
150 Hour Lubrication	Pages 23 to 28 Inclusive
300 Hour Lubrication	Pages 29 to 34 Inclusive

For the 4, 8, 40, and 150 Hour Lubrication Points, use a good grade of gun grease. For the 300 Hour, use a **high temperature ball or roller bearing grease of medium consistency. Do not use regular gun grease.**

BEARINGS.

Lubricate at all grease fittings thoroughly, with a good grade of gun grease, until grease oozes out of bearing. This assures that the bearing is full, and also flushes out dirt that may have accumulated in the bearing. However, avoid excessive lubrication. Excessive lubricant that has dropped onto belts should be wiped off immediately to avoid belt slippage.

Two types of sealed bearings are used on this combine. One type is a sealed for life bearing which requires no lubrication; the other type is pre-packed at the factory and will require yearly lubrication.

To lubricate bearings where a pipe plug is provided in bearing housing, remove the pipe plug and insert a 1/8-inch diameter slotted grease fitting (JD7805); the slotted fitting allows the bearing housing to be filled to capacity without blowing out seals due to pressure building/up. Then remove grease fitting and replace pipe plug.

Where no end cap or pipe plug is provided in bearing housing, it will be necessary to pull bearing housing from shaft to pack bearing with new grease. Clean bearing with a safe solvent and pack with new grease. Re-install bearing housing.

LUBRICATION OF LINKAGES.

When lubricating the combine, make a practice of putting a few drops of oil on all clevises, linkages, and other moving parts. This will make them work easier and prolong their life.

LUBRICATION OF CHAINS.

Chains should be lubricated at frequent intervals. A good grade of light machine oil should be used. A paint brush is a good instrument for applying oil to chains. **CAUTION: Do not oil chains when operating in sandy conditions. Sand will stick to the oiled chain and act as an abrasive.**

KNIFE LUBRICATION.

The amount of lubricant to use on a knife depends on the conditions in which the work is being done. When the grain is being topped and the cutter bar is carried some distance from the ground, liberal lubrication with oil is permissible. In conditions where the cutter bar must operate close to the ground, it is better not to use oil except for a small amount on the knife holders.

HYDRAULIC UNIT.

A premium grade of engine oil is recommended for use in the hydraulic unit—see page 33. Check oil level daily. Be sure platform is lowered to the ground when checking or adding oil.

ENGINE BREAK-IN.

The engine on your new combine is shipped from the factory with a special break-in oil in the crankcase. After 150 hours of operation, this oil must be drained from the crankcase and oil filter and replaced with 5 quarts of oil no heavier than SAE 10W or SAE 5W-20 if temperature is below 32° F.; SAE 20 or 10W-30 if temperature is above 32° F.

THE COMPLETE OBSERVANCE of one simple rule would prevent many thousand serious injuries each year. THAT RULE IS: "NEVER ATTEMPT TO CLEAN, OIL, OR ADJUST A MACHINE WHILE IT IS IN MOTION."

EVERY 4 HOURS OF OPERATION

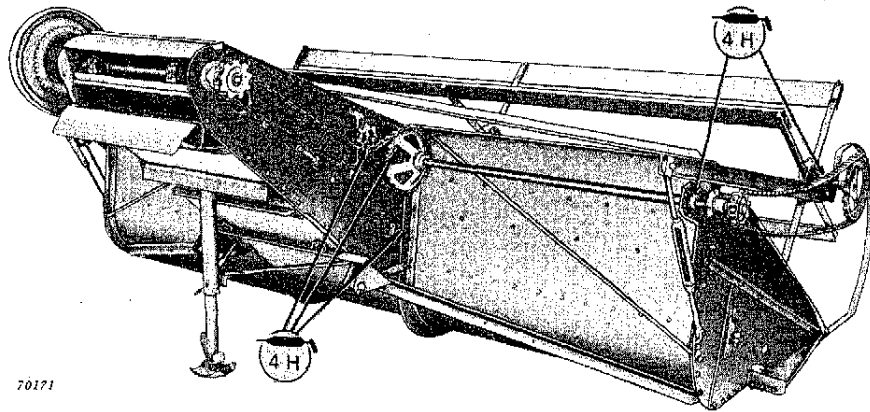

70171

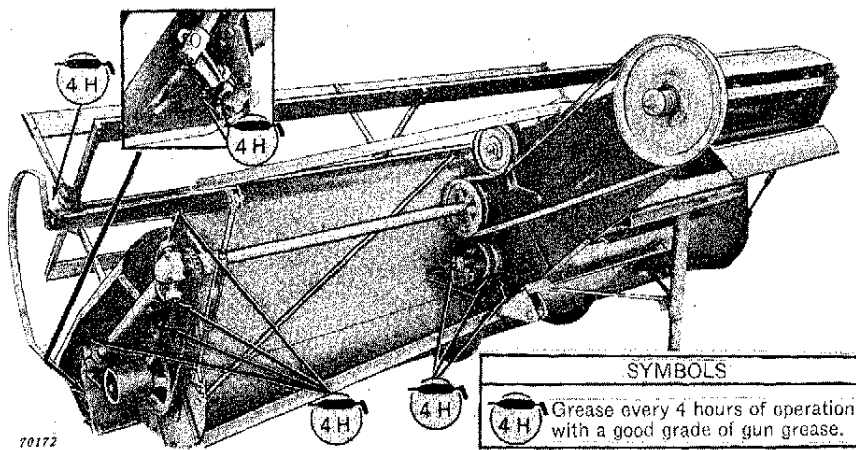

70172



Suggest:

If the above button click is invalid.

Please download this document

first, and then click the above link

to download the complete manual.

Thank you so much for reading

EVERY 4 AND 8 HOURS OF OPERATION

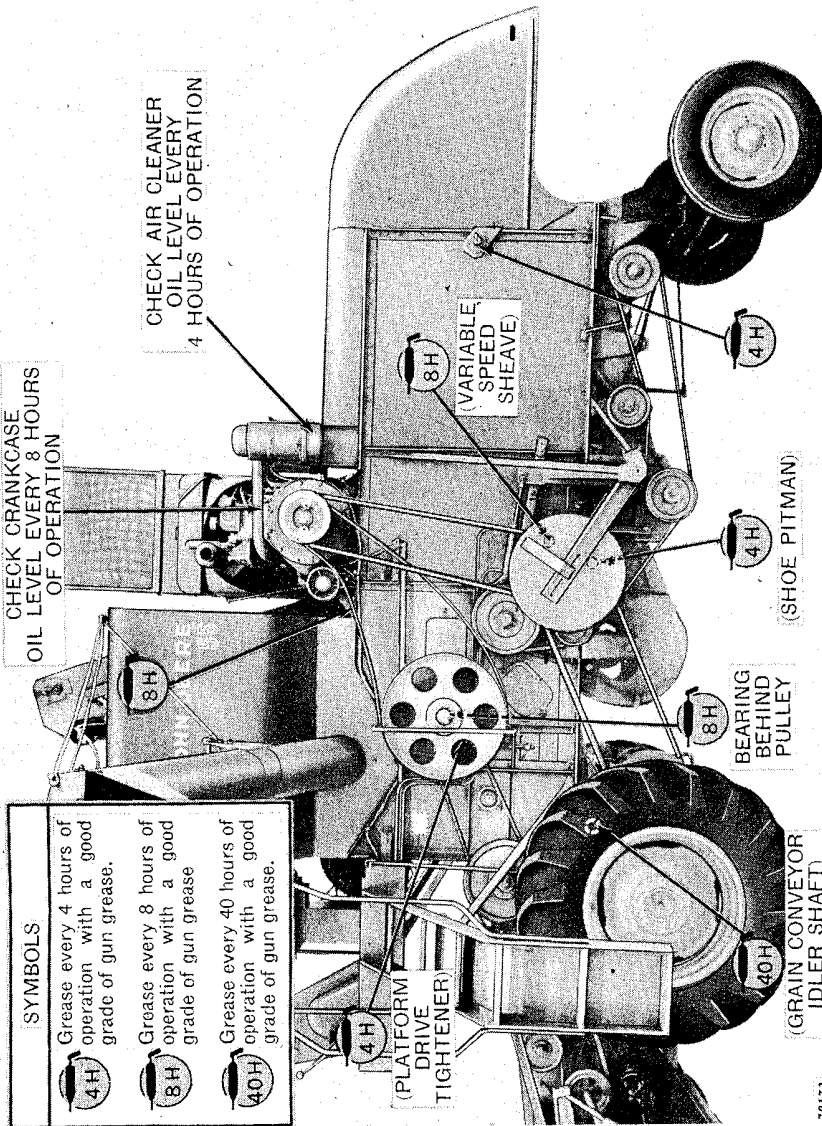

70173

<https://www.ebooklibonline.com>

Hello dear friend!

Thank you very much for reading.

Enter the link into your browser.

The full manual is available for immediate download.

<https://www.ebooklibonline.com>