

51-Inch Rotary Broom

(Serial No. 010001 –)

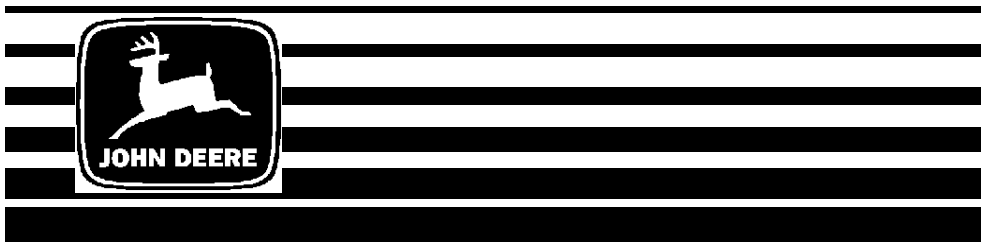

OPERATOR'S MANUAL

John Deere
Lawn & Grounds Care Division
OMM123322 I5

North American Version
Litho in U.S.A
English

INTRODUCTION

THANK YOU for purchasing a John Deere product.

This 51-Inch Rotary Broom can be used on the 318, 322, 332, 420, 425, 430, 445, and 455 Tractors.



It can also be used on the F911, F925, and F935 Front Mowers.

Throughout this manual the words 300 Series, 400 Series, and F900 Series will be referred to as:

- **Whenever you see 300 Series: This refers to models 318, 322, and 332 Tractors.**
- **Whenever you see 400 Series: This refers to models 425, 445, and 455 Tractors.**
- **Whenever you see F900 Series: This refers to models F911, F925, and F935 Front Mowers.**
- **420 and 430 Tractors will be spelled out as such.**

Read this manual and your vehicle manual thoroughly. Failure to do so could result in personal injury or equipment damage.

This manual should be considered a permanent part of your machine and should remain with the machine when you sell it.

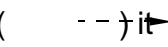
Measurements in this manual are metric units and their U.S. customary equivalents. RIGHT-HAND and LEFT-HAND sides are determined by facing in the direction the machine will travel when going forward. When you see a broken line arrow () it indicates the part it is pointing to is hidden.

Product warranty is provided as part of John Deere's support program for customers who operate and maintain their equipment as described in this manual. The product warranty is explained on the warranty certificate you received from your dealer.

INTRODUCTION

Record identification numbers below. Be sure to record all the numbers to help in tracing the machine if it is stolen. You also need to give these numbers to your dealer when you order parts.

Date of Purchase: _____

Dealer Name: _____	Phone: _____
------------------------------	------------------------

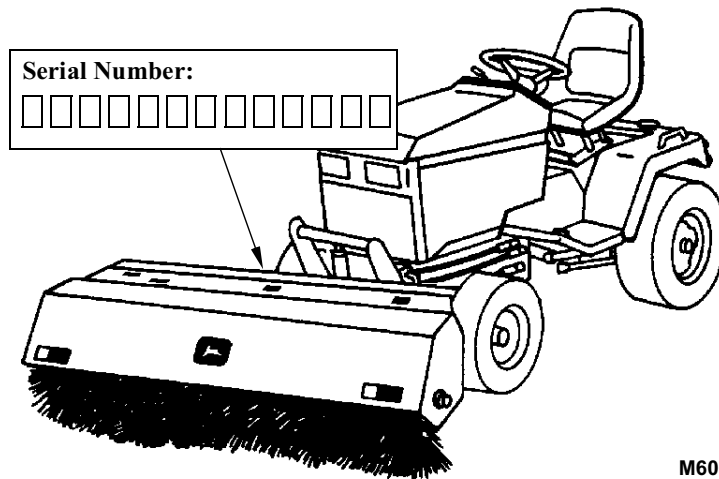

M60656

<https://www.ebooklibonline.com>

Hello dear friend!

Thank you very much for reading.

Enter the link into your browser.

The full manual is available for immediate download.

<https://www.ebooklibonline.com>

TABLE OF CONTENTS

	Page
Safety Signs	
Safety-Alert Symbol	1
Machine Safety Labels.....	1
Preparing the Vehicle	
Preparing The Tractor/Front Mower.....	3
Installing	
Park Vehicle Safely	7
Avoid High Pressure Fluids.....	7
Install PTO Shaft In Wire Support.....	8
Install Broom	8
Lock J-Pins.....	8
Reversing J-Pins	9
Install Cable Assembly Or Chain and Pin Assembly.....	10
Connect PTO Shaft	11
Removing	
Remove Broom	13
Operating	
Park Vehicle Safely	13
Avoid High Pressure Fluids.....	13
Operate Safely	15
Operate Safely On Slopes	16
Wear Appropriate Clothing.....	16
Stay Clear Of Rotating Drivelines	16
Sweeping Hard Surface	17
Sweeping Thatch	17
Sweeping Snow	18
Sweeping Leaves.....	18
Storage Stands	18

TABLE OF CONTENTS

	Page
Operating (Continued)	
Controlling Brush Speed.....	19
Engaging And Disengaging Broom.....	20
Raising And Lowering Broom	21
Angling Broom	22
Adjust Broom and Brush Height	23
Replacement Parts	
John Deere Service Parts.....	24
Service Machine Safely	
Practice Safe Maintenance.....	25
Wear Appropriate Clothing	26
Stay Clear Of Rotating Drivelines	26
Avoid High Pressure Fluids	26
Service	
Grease.....	27
Gear Oil	28
Service Intervals	29
Grease.....	29
Lubricate Wheel Bearings And Spindles	29
Lubricate Driveline U-Joints.....	29
Check Gearbox Oil Level.....	30
Replace Shear Bolt (Brush Section).....	30
Removing Brush Sections	31
Install New Brush Sections.....	32
Troubleshooting	
Using Troubleshooting Chart.....	34

TABLE OF CONTENTS

	Page
Storage	
Storage.....	35
Assembly	
Fasten Driveline To Gearbox	36
Specifications	
Machine Specifications	37
Recommended Lubricants	37
John Deere Service Literature	
Order Form.....	39

All information, illustrations and specifications in this manual are based on the latest information at the time of publication. The right is reserved to make changes at any time without notice.

COPYRIGHT© 1995
John Deere Horicon Works
All rights reserved
Previous Editions
COPYRIGHT© 1994

SAFETY SIGNS

Safety-Alert Symbol

Read and recognize safety information. Be alert to the potential for personal injury when you see this safety-alert symbol.

On your machine safety labels, the words DANGER, WARNING, and CAUTION are used with this safety-alert symbol. DANGER identifies the most serious hazards. In this manual, the word CAUTION and this symbol call attention to safety messages.



Machine Safety Labels

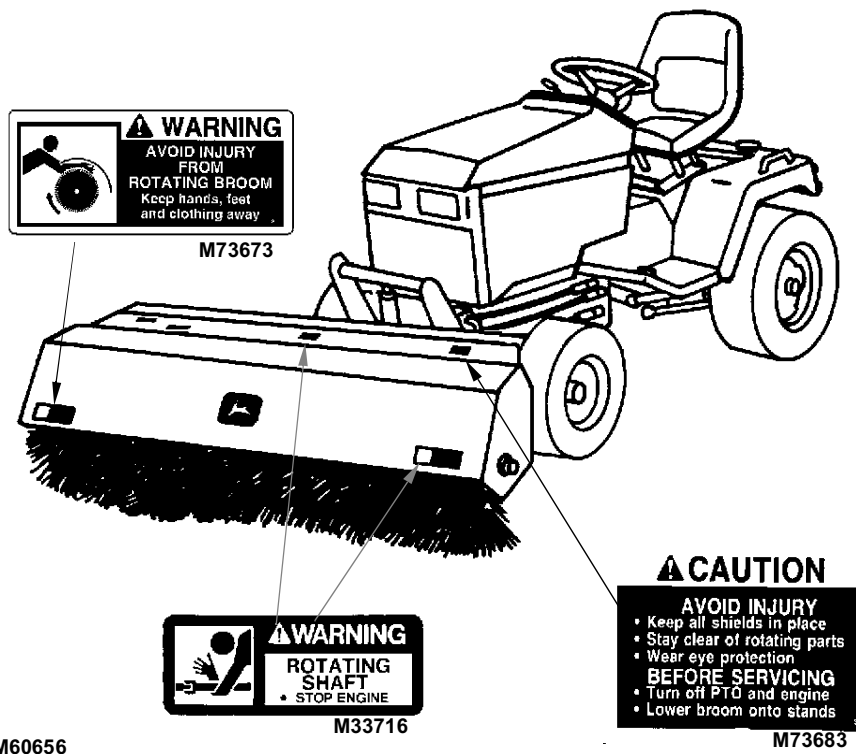

SAFETY SIGNS

Machine Safety Labels (Continued)

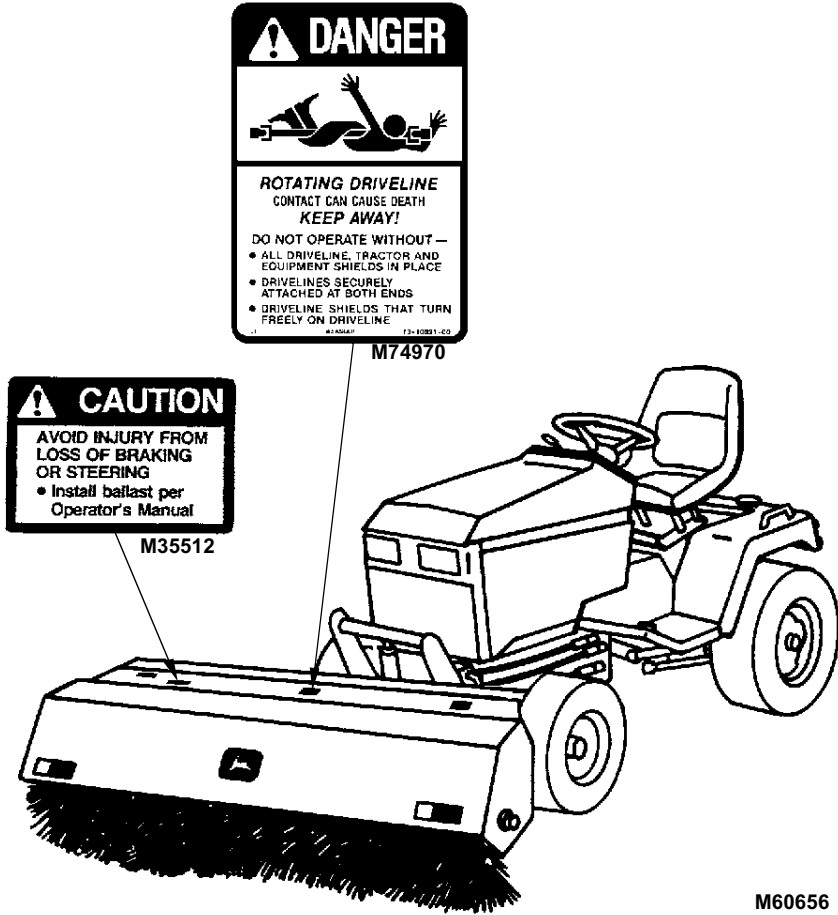

PREPARING THE VEHICLE

Preparing The Tractor/Front Mower

IMPORTANT: Ballasting is required for safe operation of your broom.

300 SERIES TRACTORS (318, 322, AND 332)*	Ballast: <ul style="list-style-type: none">• Six rear suit case weights with bracket.
400 SERIES TRACTORS (425, 445, AND 455)	Ballast: <ul style="list-style-type: none">• One suitcase weight on rear of tractor.
420, AND 430	Ballast: <ul style="list-style-type: none">• Four rear suitcase weights with bracket.
F900 SERIES (F911, F925, AND F935)	Ballast: <ul style="list-style-type: none">• Six rear bumper weights and cast iron rear bumper. (Rear Weight Kit required.)

NOTE: * Four ply tires are recommended for these models.

PREPARING THE VEHICLE

Your tractor/front mower MUST have:

	300 Series	400 Series	420 & 430	F900 Series
FRONT HITCH KIT	X	X	X	X
FRONT PTO KIT	X	X		X
FRONT PTO EXTENSION KIT			X (430 Only)	
FRONT MOUNTING EXTENSION BRACKET			X (430 Only)	
DUAL HYDRAULICS ON THE FRONT	X			
AUXILIARY HYDRAULIC KIT				X
HYDRAULIC OUTLET KIT		X (425 Only)		
HYDRAULIC ANGLING KIT	X	X	X	X

PREPARING THE VEHICLE

To improve traction:

	300 Series	400 Series	420 & 430	F900 Series
INSTALL CHAINS ON DRIVE TIRES	X	X	X	X
INSTALL WHEEL WEIGHTS ON DRIVE WHEELS	X	X	X	X
INSTALL LIQUID BALLAST IN DRIVE TIRES	X	X	X	X
PUSH DIFFERENTIAL LOCK BUTTON DOWN, IF ONE WHEEL IS SLIPPING. DURING NORMAL OPERATION DIFFERENTIAL LOCK BUTTON SHOULD NOT BE ENGAGED		X	X	X
USE INDIVIDUAL WHEEL BRAKES TO REDUCE SLIPPAGE	X		X	X

PREPARING THE VEHICLE

To improve steering on the F900 Series:

- Install wheel weights in steering tires.
- Install liquid ballast in steering tires.
- Use individual wheel brakes to make sharp turns at slow speeds.

Recommended options on 300 Series:

- 4 Ply Front Tires
- Flow Diverter Valve

Recommended options on F900 Series:

- Weight Transfer Valve (F911 and F925)

Tire Inflation:

	300 Series kPa (psi)	400 Series, 420 & 430 kPa (psi)	F900 Series kPa (psi)
FRONT: • 2 ply • 4 ply	97 (14) 150 (22)		
REAR	35–70 (5–10)	35–70 (5–10)	
FRONT: • 2 ply (16x7.50) • 4 ply (18x8.50)		97 (14) (425, 445, and 455 only) 150 (22)	
FRONT (DRIVE)			165 (24)
REAR (STEERING)			193 (28)

INSTALLING

Park Vehicle Safely

- Stop vehicle on a level surface, not on a slope.
- Disengage PTO
- STOP the engine.
- Engage the park brake.
- Remove the key.
- Before you leave the operator's seat, wait for engine and all moving parts to STOP.

Avoid High Pressure Fluids

- Escaping fluid under pressure can penetrate the skin causing serious injury. Avoid the hazard by relieving pressure before disconnecting hydraulic or other lines. Tighten all connections before applying pressure.
- Search for leaks with a piece of cardboard. Protect hands and body from high pressure fluids.
- If an accident occurs, see a doctor immediately. Any fluid injected into the skin must be surgically removed within a few hours or gangrene may result. Doctors unfamiliar with this type of injury should reference a knowledgeable medical source. Such information is available from Deere & Company Medical Department in Moline, Illinois, U.S.A.



INSTALLING

Install PTO Shaft In Wire Support

Install PTO shaft in wire support as shown.

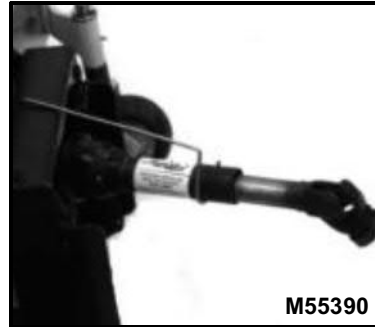

Install Broom

1. Line up tractor hitch and broom frame.
1. Pull and lock out J-pins (A).
2. Lower hitch.
3. Drive tractor forward until notches (B) on hitch are below pins (C) on frame.

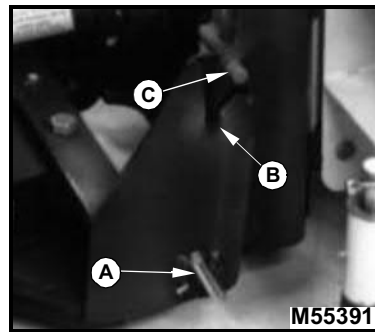

Lock J-Pins

1. Release J-pins.
2. Raise hitch until J-pins (A) snap into holes on hitch.
3. STOP engine.
4. Lock park brake.
5. CHECK: J-pins must protrude all the way through the side of the hitch frame. If not, reverse pins. See Reversing J-Pins in this section.



INSTALLING

Reversing J-Pins

NOTE: The legs of the J-pin have different dimensions for the end to the rolled pin hole: 23 mm (A) and 27 mm (B).

1. If end of J-pin does not protrude through the side the hitch, or if the broom detaches from the hitch when slid to the extreme right or left position, reverse the leg of the J-pin.

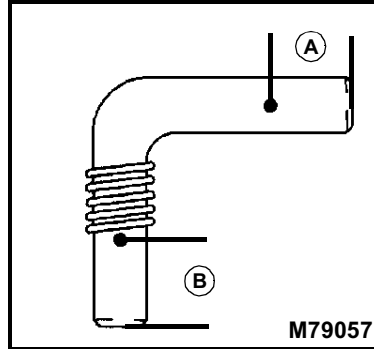

2. Drive out roll pin (C) from J-pin with punch. Save roll pin.

3. Pull J-pin from bracket and remove spring.

4. Reverse end of J-pin and install through bracket and spring.

NOTE: Spring (D) must go between roll pin (C) and inside of bracket (E).

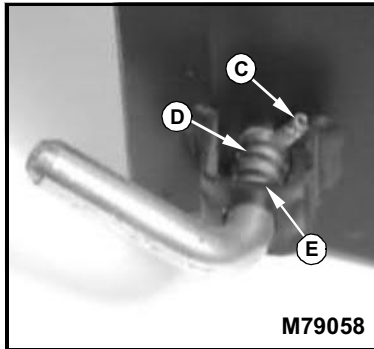

5. Install roll pin.

6. Slide broom to the extreme right and the extreme left to ensure the J-pins remain in the mounting holes.

INSTALLING

Install Cable Assembly Or Chain and Pin Assembly

NOTE: MAKE SURE assembly is in the **REAR** hole on the front hitch.

1. Move cable assembly or chain and pin assembly (A) to the rear hole (B) on front hitch.

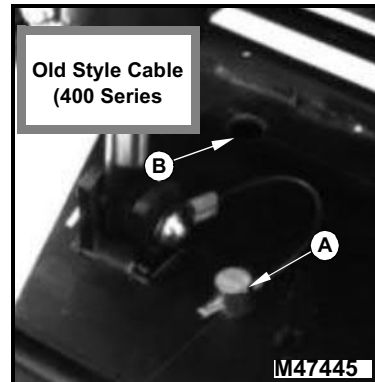

INSTALLING

Connect PTO Shaft

IMPORTANT: Failure to remove wire support from under PTO shaft **WILL** cause **DAMAGE** to guard.

1. Remove wire support from under PTO shaft.
2. Pivot wire support (A) to left and push it into clip (B).

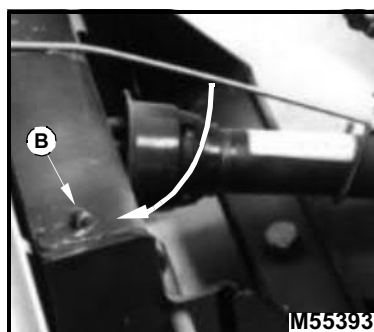
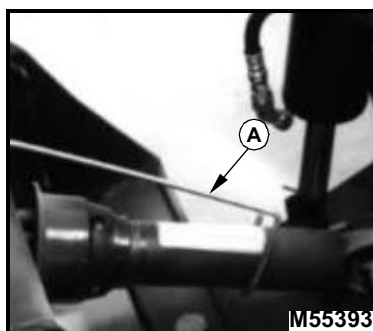

3. Pull and hold back collar (C).

NOTE: F900 Series and 400 Series will LOCK back until pushed onto tractor driveshaft.

4. Push end onto tractor driveshaft.
5. Release collar.
6. Push in until collar locks into shaft.
7. Push and pull end of driveline to make sure it is fastened.





Suggest:

If the above button click is invalid.

Please download this document

first, and then click the above link

to download the complete manual.

Thank you so much for reading

INSTALLING

8. Raise broom.

9. Remove spring clevis pin (D) and stand (E) from each side of broom.

10. Invert stands and install spring clevis pins prior to operating broom.

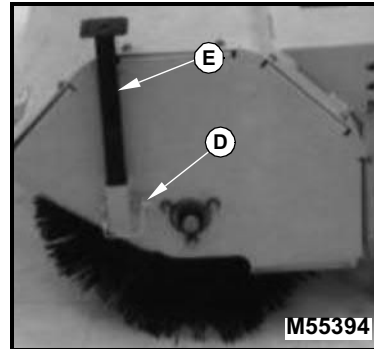

IMPORTANT: After broom is attached to front hitch, and before operating the broom, check to ensure J-pins hold broom securely to hitch.

11. Slide the broom to the extreme right and to the extreme left to ensure the J-pins remain in the mounting holes on the broom. If the broom detaches from the hitch, reverse the leg of the J-pin. See Reversing J-Pins in this section for instructions.

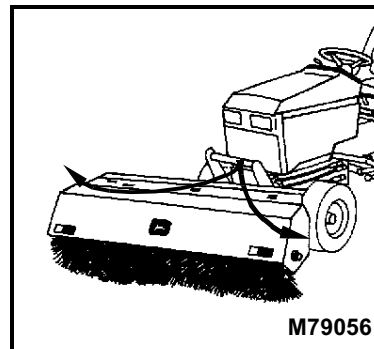

<https://www.ebooklibonline.com>

Hello dear friend!

Thank you very much for reading.

Enter the link into your browser.

The full manual is available for immediate download.

<https://www.ebooklibonline.com>