

50A SERIES ROW-CROP HEADS



JOHN DEERE

OPERATORS MANUAL 50A SERIES ROW-CROP HEADS

OMH116951 J3 English

JOHN DEERE HARVESTER WORKS
OMH116951 J3

LITHO IN THE U.S.A.
ENGLISH



INTRODUCTION

 This safety alert symbol identifies important safety messages in this manual. When you see this symbol, be alert to the possibility of personal injury and carefully read the message that follows.

NOTE: If this row-crop head is attached to any combine, other than a John Deere, be certain all exposed drives are adequately shielded.

Your operator's manual contains SI Metric equivalents which follow immediately after the U.S. customary units of measure.

"Right-hand" and "left-hand" sides are determined by facing in the direction the row-crop head will travel.

Record your row-crop head serial number in the space provided in SPECIFICATIONS.

The warranty on this row-crop head appears on your copy of the purchase order which you should have received from your dealer when making your purchase. This warranty provides you the assurance that John Deere will back its products where defects appear within the warranty period. In some circumstances, John Deere also provides field improvements, often without charge to the customer, even if the product is out of warranty.

Warranty and field improvements are a part of John Deere's product support program for customers who operate and maintain their equipment as described in this manual. Should the equipment be abused, or modified to change its performance beyond the original factory specifications, the warranty will become void and field improvements may be denied.

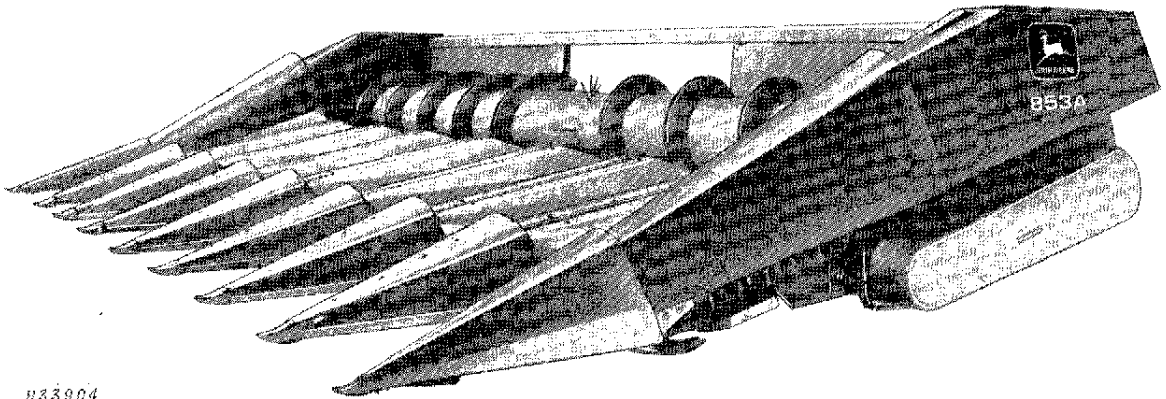

H33904

H33904



Contents

	Page
Contents	1
Safety	2-4
Attaching and Detaching	5-13
Transporting	14
Operating the Row-Crop Head	15-45
Lubricants	46,47
Lubrication and Maintenance	48,49
Trouble Shooting	50-61
Service	62-65
Storage	66
Attachments	67-69
Specifications	70,71
Index	72

<https://www.ebooklibonline.com>

Hello dear friend!

Thank you very much for reading.

Enter the link into your browser.

The full manual is available for immediate download.

<https://www.ebooklibonline.com>



Safety

SAFETY DECALS

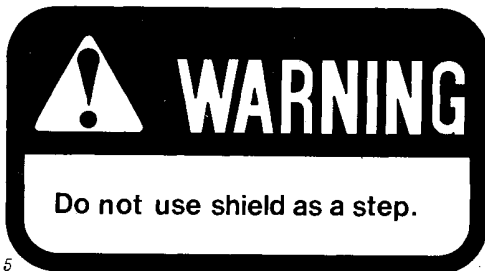

H33905

H33905

 **CAUTION, WARNING, OR DANGER:** Decals with these headings and symbol indicate the possibility of personal injury.

IMPORTANT: Decals with this heading indicate the possibility of damage to the machine.

Decals are located in areas where they apply.

AVOID CONTACT WITH MOVING PARTS

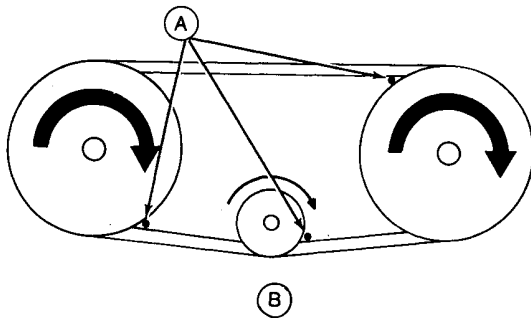

H31200

H31200

Keep hands, feet, and clothing away from power-driven parts. Be particularly careful of pinch points on belt and chain drives.

Never clean, lubricate, or adjust the row-crop head when it is running.

Never attempt to clear obstructions off the row-crop head unless the separator is disengaged and the power is shut off.

A—Pinch Points
B—Belt Drive

LEAVING COMBINE UNATTENDED

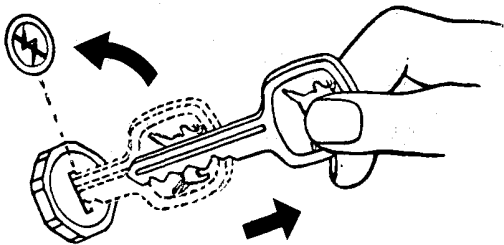

H37524

Before leaving the combine unattended, turn off engine and remove keys. Support the row-crop head with the hydraulic cylinder safety stop or lower it to the ground. Place the gearshift lever in neutral and engage the parking brake. Lock cab doors on 6620, SideHill 6620, 7720 and 8820 Combines.

TRANSPORTING

Never transport on road with 1253A Row-Crop Header attached to combine faster than 8 mph. It is recommended that you use a Model 25 Transport Frame for these 50A Series Headers.

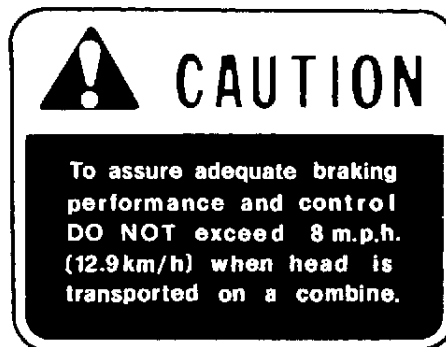

H37374

OPERATE SAFELY

Clothing worn by operator must be fairly tight and belted. Loose jackets, shirts, or sleeves must never be worn.

Any time work is being done under row-crop head, the hydraulic cylinder safety stop must be placed in the safety position.

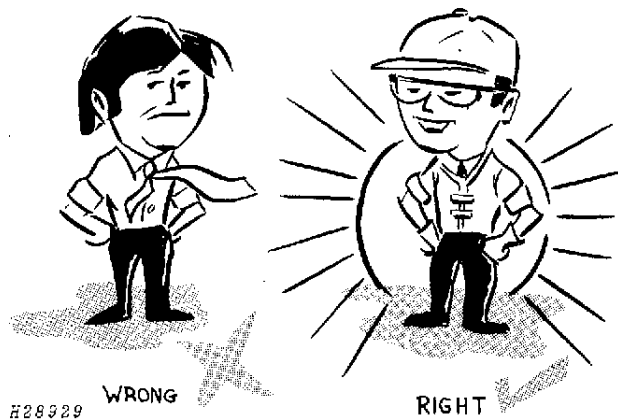

When an 8820 Combine is equipped with a 1253A Row-Crop Head, 30.5L-32 16 PR or 73 x 44.00-32 high flotation tires are required.

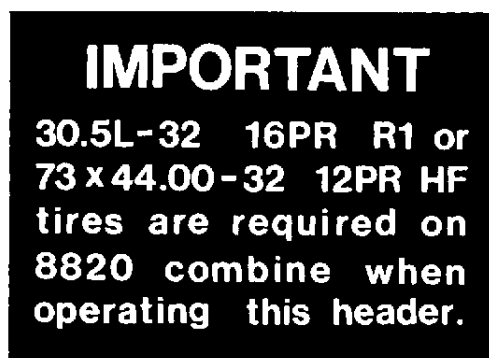

H37375

AVOID HIGH PRESSURE FLUIDS



X9811

Escaping fluid under pressure can penetrate the skin causing serious injury. Relieve pressure before disconnecting hydraulic or other lines. Tighten all connections before applying pressure. Keep hands and body away from pinholes and nozzles which eject fluids under high pressure. Use a piece of cardboard or paper to search for leaks. Do not use your hand.

If ANY fluid is injected into the skin, it must be surgically removed within a few hours by a doctor familiar with this type injury or gangrene may result.

Cracking hydraulic line fittings to lower the feeder house will result in an instantaneous dropping of feeder house or feeder house and header.

PROTECT AGAINST NOISE

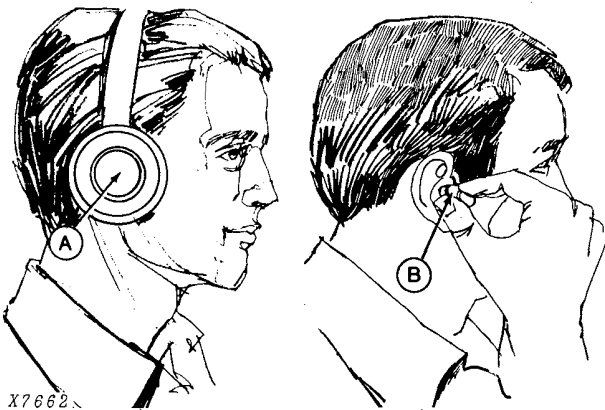

X7662

X7662

Prolonged exposure to loud noise can cause impairment or loss of hearing.

Wear a suitable hearing protective device as earmuffs (A) or earplugs (B) to protect against objectionable or uncomfortable loud noises.

A—Earmuffs
B—Earplugs



Attaching and Detaching

ATTACHING ROW-CROP HEAD TO 4400 (-350000), 6600, 7700, AND 7701 COMBINES

1. Install coupler on lower feeder house shaft.
2. Start engine and lower feeder house.
3. Move combine slowly forward until feeder house is centered in row-crop head opening. Raise feeder house lifting row-crop all the way up.
4. Disconnect chain (A) and lower hydraulic cylinder safety stop (B) on lift cylinder.

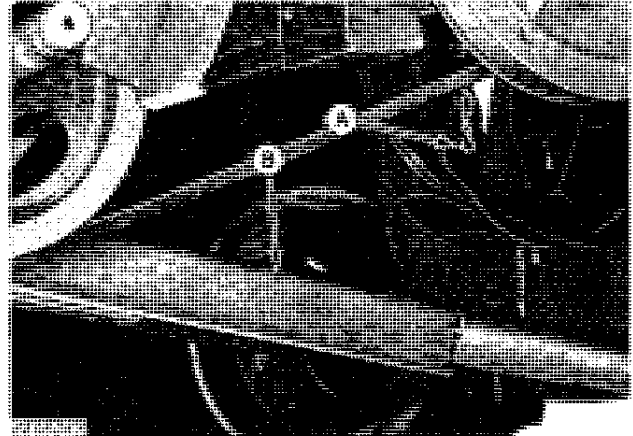

A—Chain
B—Safety Stop

H30808Y

5. Secure row-crop head to feeder house with three 1/2 x 1-1/2-inch round head bolts and 17/32 x 1-1/4 x .180-inch flat washers in bottom holes.
6. Place roller chain around sprockets, slide coupler over sprockets and chain. Repeat procedure on other side.
7. Connect Automatic Header Height Control harness if so equipped.

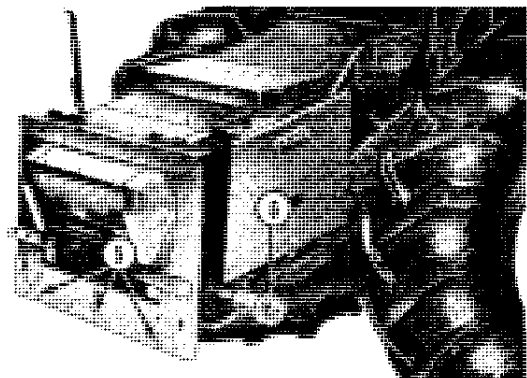

H33008Y

H33008Y

DETACHING ROW-CROP HEAD FROM 4400 (-350000), 6600, 7700 AND 7701 COMBINES

1. Start engine and raise row-crop head all the way up. Shut off engine.
2. Disconnect chain and lower hydraulic cylinder safety stop on lift cylinder.
3. Slide coupler off sprockets and chain, and remove coupler chain. Repeat procedure on other side.
4. Disconnect Automatic Header Height Control harness if so equipped.
5. Remove three 1/2 x 1-1/2-inch round head bolts and 17/32 x 1-1/4 x .180-inch flat washers.
6. Raise hydraulic cylinder safety stop and hook chain.
7. Start engine and lower feeder house until row-crop head is on ground and attaching blocks are free.
8. Move combine slowly rearward until feeder house is clear of row-crop head.

ATTACHING ROW CROP HEAD TO 4400 (350001-) 4420, 6620, 7720, 7721 and 8820 COMBINES

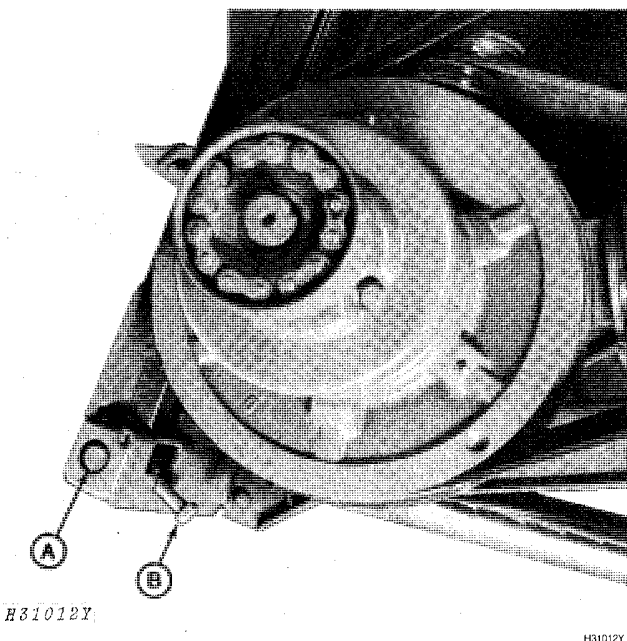

IMPORTANT: Lock pin (A) (both sides) must be positioned in before attaching header. Position pin by sliding stop bolt (B) in and then pivoting it down. If pins are left in the out position, damage to the feeder house will result when mounting a header.

NOTE: If belt pickup or cutting platform was used prior to using row-crop head, the pressure line and return line for belt pickup or reel drive must be connected together under the operators platform or on the feeder house.

A—Lock Pin
B—Stop Pin

1. Install coupler on lower feeder house shaft.

NOTE: Two couplers, shipped with the feeder house are used on the 653A, 654A, 655A, 853A, 854A and 1253A Row-Crop heads. An extra coupler is shipped with the 8820 Combine and must be installed on the left-hand row-crop shaft as follows:

1. (Not illustrated) Remove snap ring on left-hand drive shaft. Save snap ring.
2. Slide off coupler sprocket and shield.
3. Install Quik-Coupler (A) with shield.
4. Secure with snap ring (B).

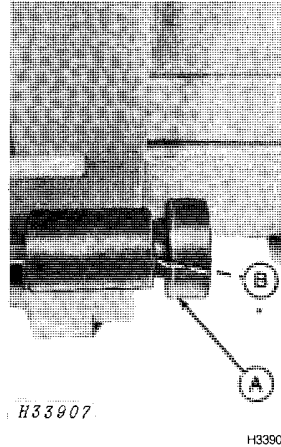

A—Quik Coupler
B—Snap Ring

2. Start engine and lower feeder house.
3. Move combine slowly forward until feeder house is centered in row-crop head opening. Raise feeder house, lifting row-crop head, all the way up. Shut off engine.
4. Disconnect chain (A) and lower hydraulic cylinder safety stop (B) on lift cylinder.

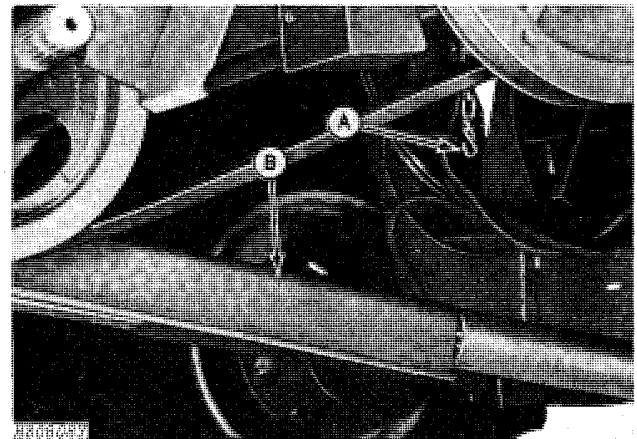

A—Chain
B—Safety Stop

8 Attaching and Detaching

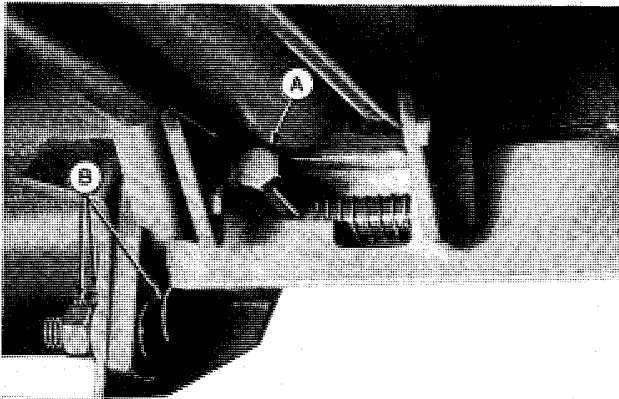

H33359Y

5. Pivot stop bolt (A) up allowing lock pin to lock into header. Repeat procedure for other side.

NOTE: Loosen mating lock plate (B) on the row-crop head, to allow the lock pin to center. Retighten lock plate.

A—Stop Bolt
B—Mating Lock Plate

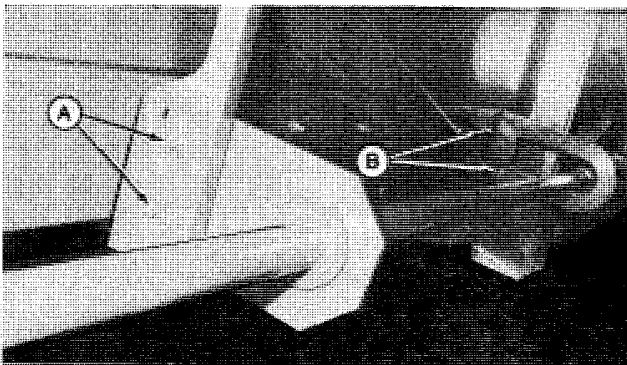

H50317

6. (854A and 1253A Row-Crop Heads only) Loosen two bolts in bearing retaining bracket (A), and in shaft support bracket (B). Both brackets must be loose. Repeat procedure on other side.
7. (854A and 1253A Row-Crop Heads only) Place roller chain around sprockets, slide coupler over sprockets and chain, and position shield over coupler. Repeat procedure on other side.
8. (854A and 1253A Row-Crop Heads only) Start combine engine and engage header with engine at slow idle. Allow drive shafts to align, and bearing bracket to find its center. Disengage header and shut off engine.
9. (854A and 1253A Row-Crop Heads only) Secure two bolts in bearing retaining bracket (A), and in shaft support bracket (B) so bracket does not rub on shaft. Repeat procedure on other side. Head and combine shafts are now aligned.
10. Connect header height control harness if so equipped.

DETACHING ROW-CROP HEAD FROM 4400 (350001-4420, 6620, 7720, 7721 and 8820 Combines),

1. Start engine and raise row-crop head all the way up. Shut off engine.
2. Disconnect chain and lower hydraulic cylinder safety stop on lift cylinder.
3. Slide coupler off sprockets and chain and remove coupler chain. Repeat procedure on other side.
4. Disconnect header height control harness if so equipped.
5. Slide and pivot stop bolt down, allowing lock pin to unlock row-crop head. Repeat procedure on other side.
6. Raise hydraulic cylinder safety stop and hook chain.
7. Start engine and lower feeder house until row-crop head is on ground and attaching blocks are free.
8. Move combine slowly rearward until feeder house is clear of row-crop head.

ATTACHING ROW-CROP HEAD TO SIDEHILL 6600 AND SIDEHILL 6620 (-358900)

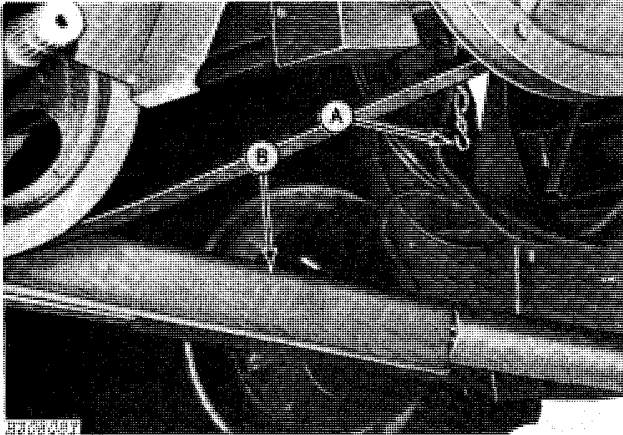

NOTE: Only 454A and 653A Row-Crop Heads are used on SideHill 6620 Combines.

1. Start engine and lower feeder house.
2. Move combine slowly forward until feeder house is centered in row-crop head opening. Raise feeder house lifting row-crop head, all the way up. Shut off engine.
3. Disconnect chain (A) and lower hydraulic cylinder safety stop (B) on lift cylinder.

A—Chain
B—Safety Stop

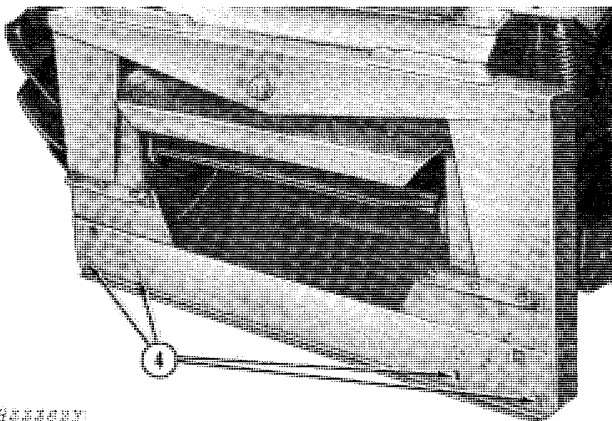

4. Secure row-crop head to feeder house with four 1/2 x 1-1/2-inch round head bolts and 17/32 x 1-1/4 x .180-inch flat washers.
5. Install telescoping drive shaft between row-crop head and feeder house.
6. Install 5/16 x 2-1/2-inch cap screw then tighten clamp on inner end of telescoping drive shaft.
7. Connect Automatic Header Height Control harness if so equipped.

DETACHING ROW-CROP HEAD FROM SIDEHILL 6600 AND SIDEHILL 6620 (-358900) COMBINES

1. Start engine and raise row-crop head all the way up. Shut off engine.
2. Disconnect chain and lower hydraulic cylinder safety stop on lift cylinder.
3. Remove 5/8 x 2-1/2-in. cap screw; then loosen cap screw in clamp and disconnect telescoping drive shaft. Repeat procedure on other side.
4. Disconnect Automatic Header Height Control harness if so equipped.
5. Remove four 1/2 x 1-1/2-inch round head bolts and 17/32 x 1-1/4 x .180-inch flat washers.
6. Raise hydraulic cylinder safety stop and hook chain.
7. Start engine and lower feeder house until row-crop head is on ground and attaching blocks are free.
8. Move combine slowly rearward until feeder house is clear of row-crop head.

ATTACHING ROW-CROP HEAD TO SIDEHILL 6620 (403301-) COMBINES

IMPORTANT: Lock pin (A) (both sides) must be positioned in before attaching header. Position pin by sliding stop bolt (B) in and then pivoting it down. If pins are left in the out position, damage to the feeder house will result when mounting a header.

NOTE: If belt pickup or cutting platform was used prior to using row-crop head, the pressure line and return line for belt pickup or reel drive must be connected together under the operators platform or on the feeder house.

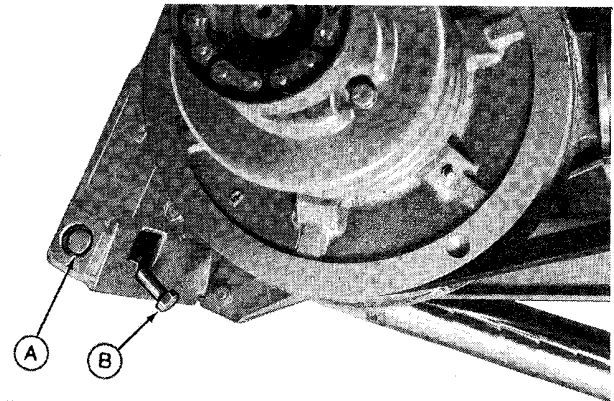

H33357

H33357

A—Lock Pin
B—Stop Bolt

NOTE: Only 454A and 653A Row-Crop Heads are used on SideHill 6620 Combines.

1. Start engine and lower feeder house.
2. Move combine slowly forward until feeder house is centered in row-crop head opening. Raise feeder house, lifting row-crop head, all the way up. Shut off engine.

12 Attaching and Detaching

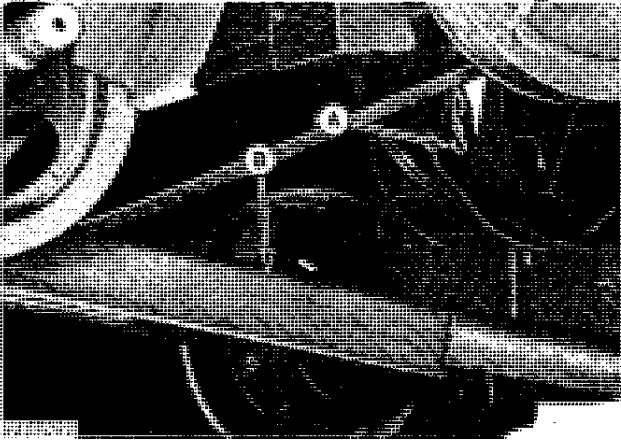

3. Disconnect chain (A) and lower hydraulic cylinder safety stop (B) on lift cylinder.

A—Chain
B—Safety Stop

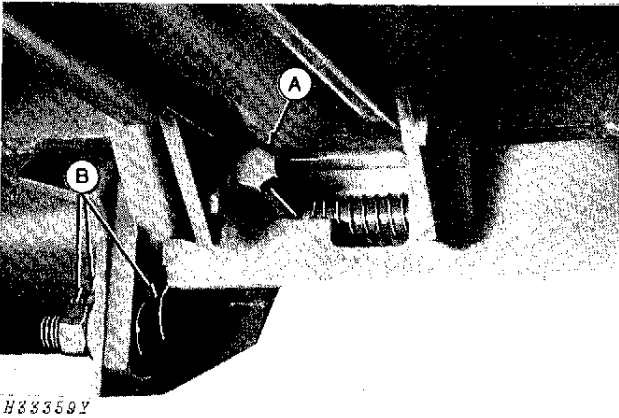

4. Pivot stop bolt (A) up, allowing lock pin to lock into row-crop head. Repeat procedure for other side.

NOTE: Loosen mating lock plate (B) on the row-crop head, to allow the lock pin to center. Retighten lock plate.

A—Stop Bolt
B—Mating Lock Plate

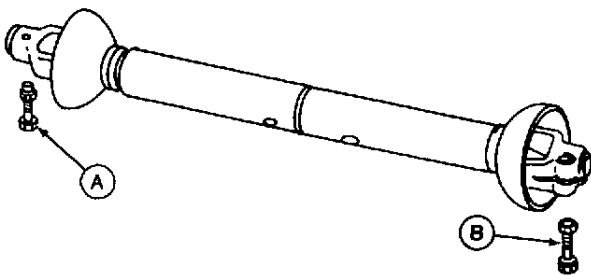

Left-Hand Drive Shaft Illustrated

5. Install telescoping drive shaft between row-crop head and feeder house.
6. Tighten cap screw (B) on inner end of telescoping drive shaft and install 5/16 x 2-1/2-in. cap screw (A), lock washer and nut thru outer end.
7. Repeat steps 5 and 6 on other side if necessary.
8. Connect header height control harness if so equipped.

DETACHING ROW-CROP HEAD FROM SIDEHILL 6620 (403301-) COMBINES

1. Start engine and raise row-crop head all the way up. Shut off engine.
2. Disconnect chain and lower hydraulic cylinder safety stop on lift cylinder.
3. Loosen cap screw (B) on inner end and remove cap screw (A) then disconnect telescoping drive shaft at feeder house (shafts stay with header). Repeat procedure on other side if necessary.
4. Disconnect header height control harness if so equipped.
5. Slide and pivot stop bolt down, allowing lock pin to unlock row-crop head. Repeat procedure on other side.
6. Raise hydraulic cylinder safety stop and hook chain.
7. Start engine and lower feeder house until row-crop head is on ground and attaching blocks are free.
8. Move combine slowly rearward until feeder house is clear of row-crop head.

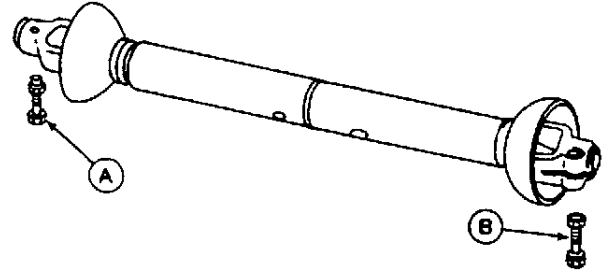

Left-Hand Drive Shaft Illustrated

H36883



Transporting

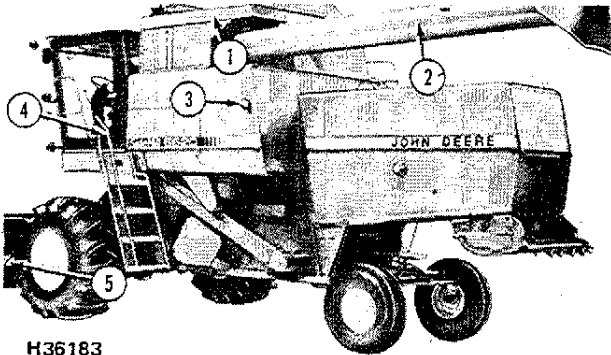

H36183

H36183

Check local width laws before transporting.

The row-crop head can be transported by leaving it attached to the combine.

CAUTION: Never transport on road with 1253A Row-Crop Head attached to Combine faster than 8 mph. It is recommended that you use a model 25 Transport Frame for these 50 Series Headers.

1. Empty grain tank.
2. Swing unloading auger back and secure with transport brace.
3. Turn on combine flashing warning light, unless prohibited by local law.
4. Couple combine brake pedals together.
5. Raise row-crop head to a position that will keep it off the ground but still allow good visibility.
6. If transporting over rough terrain or extended distance, lock the row units in rigid position and lower safety stop on lift cylinder.

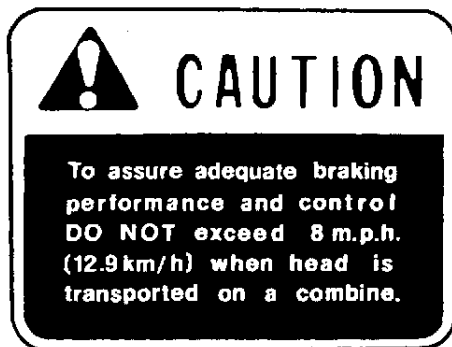

H37374



Suggest:

If the above button click is invalid.

Please download this document

first, and then click the above link

to download the complete manual.

Thank you so much for reading



Operating the Row-Crop Head

GENERAL INFORMATION

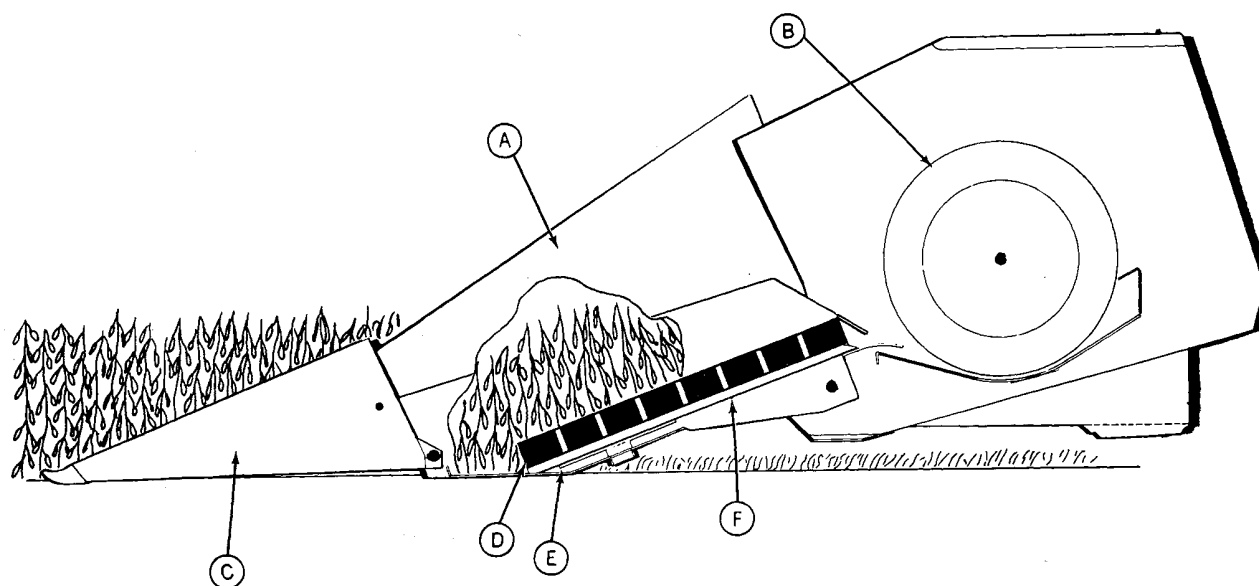

H26051

A—Outer Gatherer Sheet
B—Auger

C—Outer Gatherer Point
D—Gathering Belts

E—Rotary Knife
F—Trough

The 50A Series Row-Crop Head is designed for harvesting soybeans, maize, and other row crops such as millet and sunflowers.

As the combine moves through the field, the row crop head gatherer points are positioned between the rows. Gatherer points lift and guide crop into the gathering belts.

The gathering belts extend forward of the rotary knife to grip each stalk before it is cut. After the rotary knives have cut the stalks, the gathering belts then convey them to the sump type auger. A trough, located under the gathering belts, reduces crop loss due to shatter. The auger conveys the crop to the feeder house which delivers it to the threshing cylinder.

It is important that gather belt speed be approximately the same as combine ground speed.

<https://www.ebooklibonline.com>

Hello dear friend!

Thank you very much for reading.

Enter the link into your browser.

The full manual is available for immediate download.

<https://www.ebooklibonline.com>