

# 50A SERIES ROW-CROP HEADS



JOHN DEERE

## OPERATORS MANUAL 50A SERIES ROW-CROP HEADS

OMH111335 I1 English

HARVESTER WORKS  
OMH111335 I1

LITHO IN THE U.S.A.  
ENGLISH

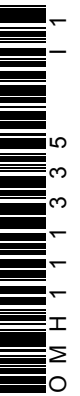

## INTRODUCTION



This safety alert symbol identifies important safety messages in this manual. When you see this symbol, be alert to the possibility of personal injury and carefully read the message that follows.

*NOTE: If this row-crop head is attached to any combine, other than a John Deere, be certain all exposed drives are adequately shielded.*

Your operator's manual contains SI Metric equivalents which follow immediately after the U.S. customary units of measure.

"Right-hand" and "left-hand" sides are determined by facing in the direction the row-crop head will travel.

Record your row-crop head serial number in the space provided on page 67.

The warranty on this row-crop head appears on your copy of the purchase order which you should have received from your dealer when making your purchase. This warranty provides you the assurance that John Deere will back its products where defects appear within the warranty period. In some circumstances, John Deere also provides field improvements, often without charge to the customer, even if the product is out of warranty.

Warranty and field improvements are a part of John Deere's product support program for customers who operate and maintain their equipment as described in this manual. Should the equipment be abused, or modified to change its performance beyond the original factory specifications, the warranty will become void and field improvements may be denied.

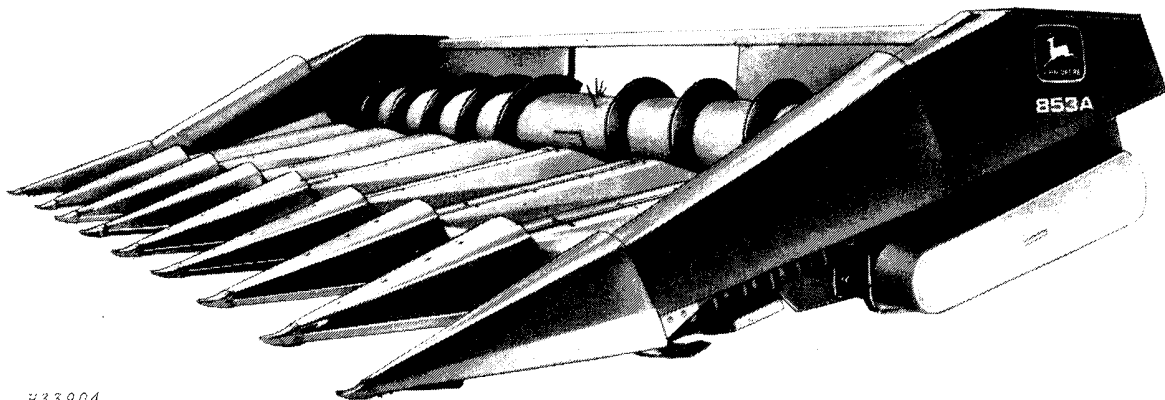

H33904



# Contents

---

	Page
Contents .....	1
Safety .....	2
Attaching and Detaching .....	4
Transporting .....	12
Operating the Row-Crop Head .....	13
Lubrication and Maintenance .....	44
Trouble Shooting .....	46
Service .....	58
Storage .....	62
Attachments .....	63
Specifications .....	66
Index .....	68

**<https://www.ebooklibonline.com>**

Hello dear friend!

Thank you very much for reading.

Enter the link into your browser.

The full manual is available for immediate download.

**<https://www.ebooklibonline.com>**



# Safety

 **Unauthorized modifications to the row-crop head may impair the function and or safety and affect machine life.**

## SAFETY DECALS

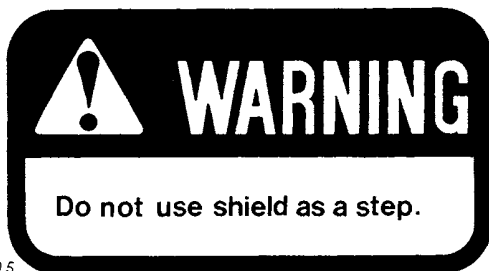

H33905

 **CAUTION OR WARNING:** Decals with these headings and symbol indicate the possibility of personal injury.

**IMPORTANT:** Decals with this heading indicate the possibility of damage to the machine.

Decals are located in areas where they apply.

## AVOID CONTACT WITH MOVING PARTS

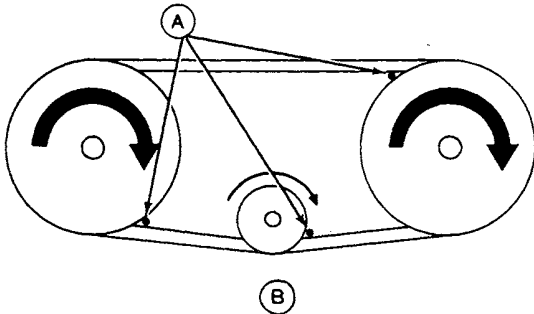

H31200

Keep hands, feet, and clothing away from power-driven parts. Be particularly careful of pinch points on belt and chain drives.

Never clean, lubricate, or adjust the row-crop head when it is running.

Never attempt to clear obstructions off the row-crop head unless the separator is disengaged and the power is shut off.

**A—Pinch Points**  
**B—Belt Drive**

## LEAVING COMBINE UNATTENDED

Before leaving the combine unattended, turn off engine and remove keys. Support the row-crop head with the hydraulic cylinder safety stop or lower it to the ground. Place the gearshift lever in neutral and engage the parking brake. Lock cab doors on 6620, SideHill 6620, 7720 and 8820 Combines.

## OPERATE SAFELY

Clothing worn by operator must be fairly tight and belted. Loose jackets, shirts, or sleeves must never be worn.

Any time work is being done under row-crop head, the hydraulic cylinder safety stop must be placed in the safety position. Refer to page 15.

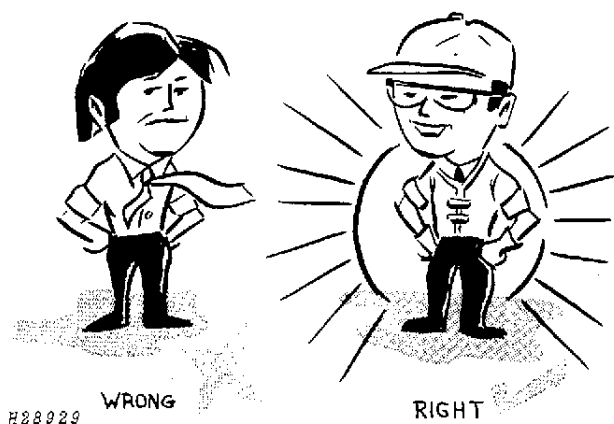

## AVOID HIGH PRESSURE LEAKS

Escaping hydraulic fluid under pressure can have sufficient force to penetrate the skin, causing serious injury. Before disconnecting lines, relieve all pressure. Before applying pressure to the system, all connections must be tight and lines, pipes, and hoses must be in good condition.

Fluid escaping from a very small hole can be almost invisible. Use a piece of cardboard or wood, rather than hands, to search for suspected leaks.

If injured by escaping fluid, see a doctor at once. Serious infection or reaction can develop if proper medical treatment is not administered immediately.

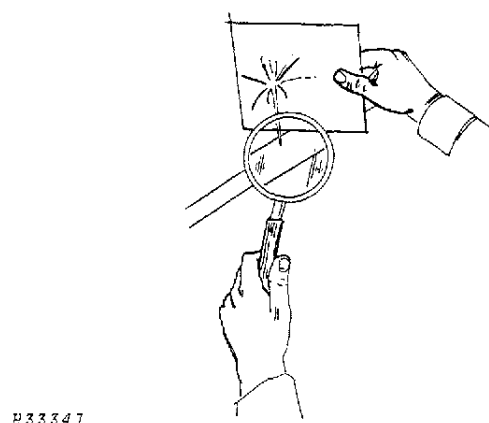

## PROTECT AGAINST NOISE

Prolonged exposure to loud noise can cause impairment or loss of hearing.

Wear a suitable hearing protective device as earmuffs (A) or earplugs (B) to protect against objectionable or uncomfortable loud noises.

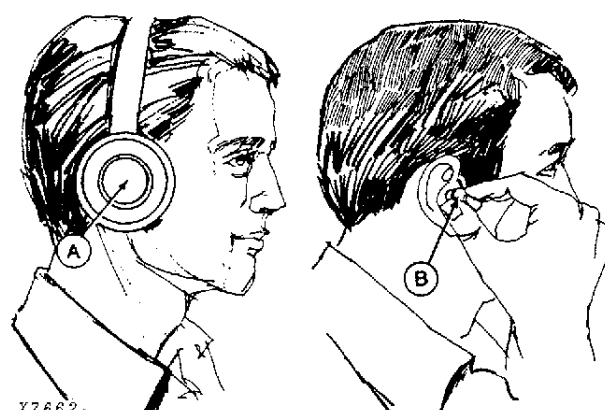

A—Earmuffs  
B—Earplugs



# Attaching and Detaching

## ATTACHING ROW-CROP HEAD TO 4400 ( -350000), 6600, 7700, AND 7701 COMBINES

1. Install coupler on lower feeder house shaft.
2. Start engine and lower feeder house.
3. Move combine slowly forward until feeder house is centered in row-crop head opening. Raise feeder house lifting row-crop all the way up.
4. Disconnect chain (A) and lower hydraulic cylinder safety stop (B) on lift cylinder.

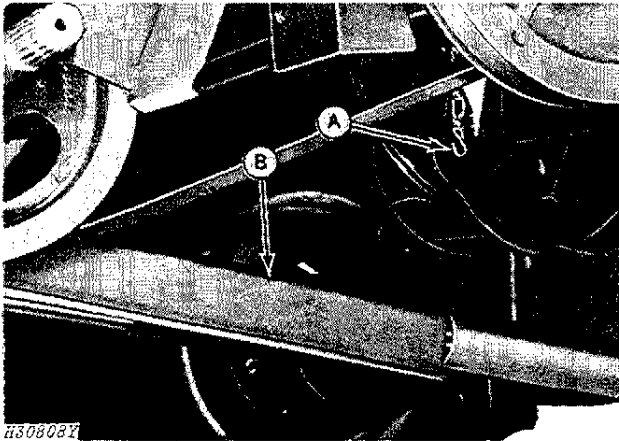

A—Chain  
B—Safety Stop

5. Secure row-crop head to feeder house with three 1/2 x 1-1/2-inch round head bolts and 17/32 x 1-1/4 x .180-inch flat washers in bottom holes.
6. Place roller chain around sprockets, slide coupler over sprockets and chain. Repeat procedure on other side.
7. Connect Automatic Header Height Control harness if so equipped.

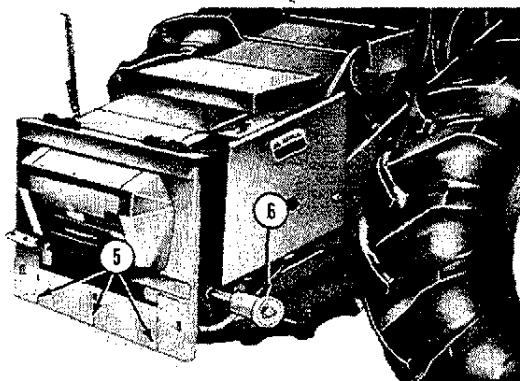

H33906Y



## 6 Attaching & Detaching

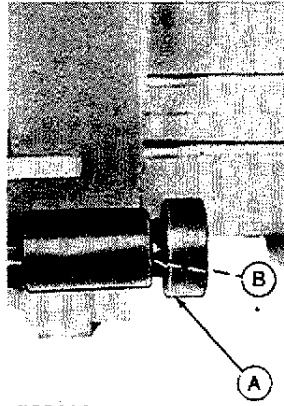

1. Install coupler on lower feeder house shaft.

**NOTE:** Two couplers, shipped with the feeder house are used on the 653A, 654A, and 853A row crop heads. An extra coupler is shipped with the 8820 and must be installed on the left-hand row-crop shaft as follows:

1. (Not illustrated) Remove snap ring on left-hand drive shaft. Save snap ring.
2. Slide off coupler sprocket and shield.
3. Install Quik-Coupler (A) with shield.
4. Secure with snap ring (B).

A—Quik Coupler  
B—Snap Ring

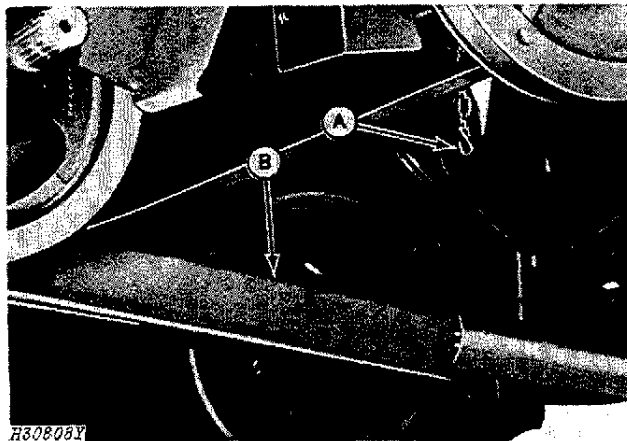

2. Start engine and lower feeder house.
3. Move combine slowly forward until feeder house is centered in row crop head opening. Raise feeder house, lifting row-crop head, all the way up. Shut off engine.
4. Disconnect chain (A) and lower hydraulic cylinder safety stop (B) on lift cylinder.

A—Chain  
B—Safety Stop

- Pivot stop bolt (A) up allowing lock pin to lock into header. Repeat procedure for other side.

*NOTE: Loosen mating lock plate (B) on the row-crop head, to allow the lock pin to center. Retighten lock plate.*

- Place roller chain around sprockets, slide coupler over sprockets and chain. Repeat procedure for other side.
- Connect header height control harness if so equipped.

A—Stop Bolt  
B—Mating Lock Plate

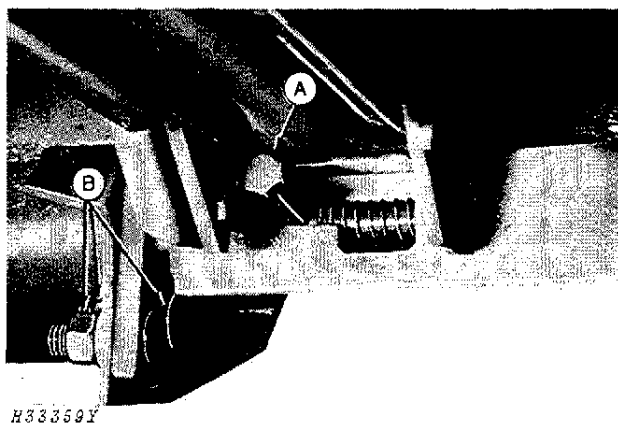

H33359Y

## DETACHING ROW-CROP HEAD FROM 4400 (350001-4420, 6620, 7720, 7721 and 8820 Combines),

- Start engine and raise row-crop head all the way up. Shut off engine.
- Disconnect chain and lower hydraulic cylinder safety stop on lift cylinder.
- Slide coupler off sprockets and chain and remove coupler chain. Repeat procedure on other side.
- Disconnect header height control harness if so equipped.
- Slide and pivot stop bolt down, allowing lock pin to unlock row-crop head. Repeat procedure on other side.
- Raise hydraulic cylinder safety stop and hook chain.
- Start engine and lower feeder house until row-crop head is on ground and attaching blocks are free.
- Move combine slowly rearward until feeder house is clear of row-crop head.

## ATTACHING ROW-CROP HEAD TO SIDEHILL 6600 AND SIDEHILL 6620 ( -358900)

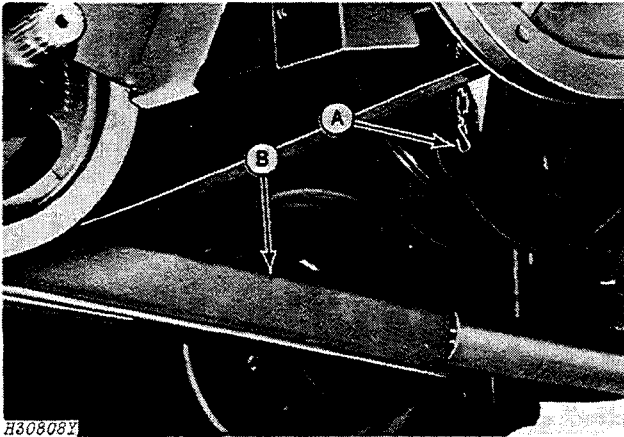

H30808Y

1. Start engine and lower feeder house.
2. Move combine slowly forward until feeder house is centered in row-crop head opening. Raise feeder house lifting row-crop head, all the way up. Shut off engine.
3. Disconnect chain (A) and lower hydraulic cylinder safety stop (B) on lift cylinder.

A—Chain  
B—Safety Stop

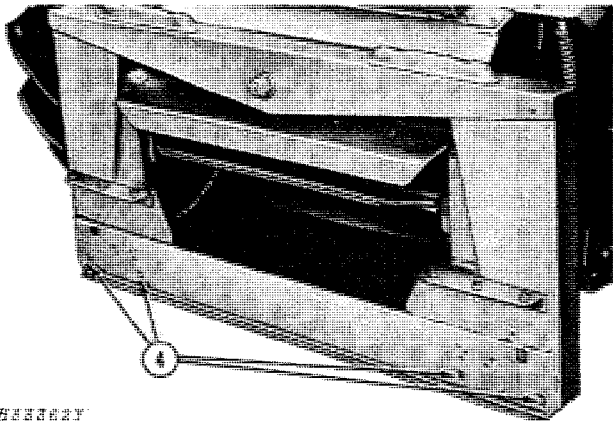

H30809Y

4. Secure row-crop head to feeder house with four 1/2 x 1-1/2-inch round head bolts and 17/32 x 1-1/4 x .180-inch flat washers.
5. Install telescoping drive shaft between row-crop head and feeder house.
6. Install 5/16 x 2-1/2-inch cap screw then tighten clamp on inner end of telescoping drive shaft.
7. Connect Automatic Header Height Control harness if so equipped.

## DETACHING ROW-CROP HEAD FROM SIDEHILL 6600 AND SIDEHILL 6620 ( -358900) COMBINES

1. Start engine and raise row-crop head all the way up. Shut off engine.
2. Disconnect chain and lower hydraulic cylinder safety stop on lift cylinder.
3. Remove 5/8 x 2-1/2 cap screw then loosen cap screw in clamp and disconnect telescoping drive shaft. Repeat procedure on other side.
4. Disconnect Automatic Header Height Control harness if so equipped.
5. Remove four 1/2 x 1-1/2-inch round head bolts and 17/32 x 1-1/4 x .180-inch flat washers.
6. Raise hydraulic cylinder safety stop and hook chain.
7. Start engine and lower feeder house until row-crop head is on ground and attaching blocks are free.
8. Move combine slowly rearward until feeder house is clear of row-crop head.

## ATTACHING ROW-CROP HEAD TO SIDEHILL 6620 (403301- ) COMBINES

**IMPORTANT:** Lock pin (A) (both sides) must be positioned in before attaching header. Position pin by sliding stop bolt (B) in and then pivoting it down. If pins are left in the out position, damage to the feeder house will result when mounting a header.

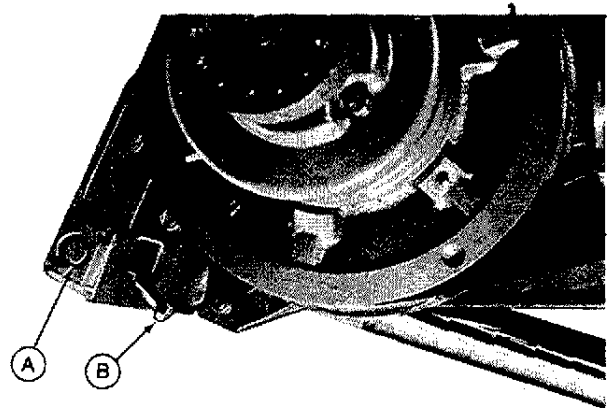

#35357

A—Lock Pin  
B—Stop Bolt

1. Start engine and lower feeder house.
2. Move combine slowly forward until feeder house is centered in row-crop head opening. Raise feeder house, lifting row-crop head, all the way up. Shut off engine.

## 10 Attaching and Detaching

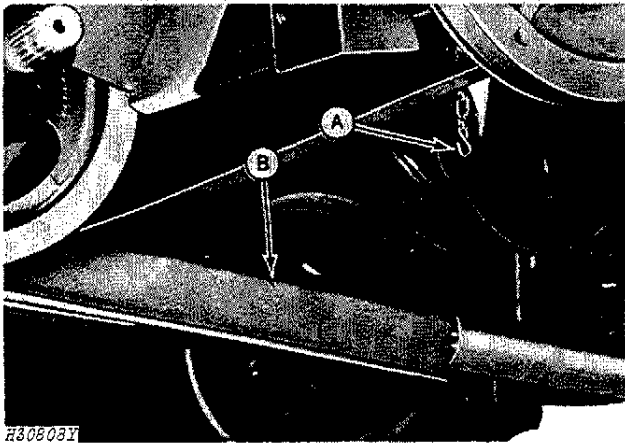

3. Disconnect chain (A) and lower hydraulic cylinder safety stop (B) on lift cylinder.

A—Chain  
B—Safety Stop

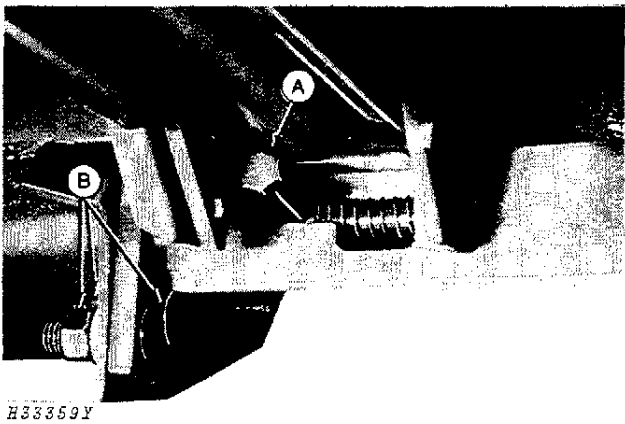

4. Pivot stop bolt (A) up, allowing lock pin to lock into row-crop head. Repeat procedure for other side.

*NOTE: Loosen mating lock plate (B) on the row-crop head, to allow the lock pin to center. Retighten lock plate.*

A—Stop Bolt  
B—Mating Lock Plate

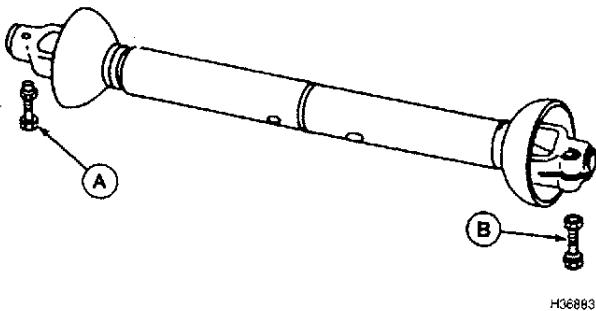

*Left-Hand Drive Shaft Illustrated*

A—Clamp  
B—Cap Screw

5. Install telescoping drive shaft between row-crop head and feeder house.
6. Tighten clamp (A) on inner end of telescoping drive shaft and install 5/16 x 2-1/2-inch cap screw (B), lock washer and nut thru outer end.
7. Repeat steps 5 and 6 on other side if necessary.
8. Connect header height control harness if so equipped.

## DETACHING ROW-CROP HEAD FROM SIDEHILL 6620 (403301- ) COMBINES

1. Start engine and raise row-crop head all the way up. Shut off engine.
2. Disconnect chain and lower hydraulic cylinder safety stop on lift cylinder.
3. Loosen clamp (A) on inner end and remove cap screw (B) then disconnect telescoping drive shaft. Repeat procedure on other side if necessary.
4. Disconnect header height control harness if so equipped.
5. Slide and pivot stop bolt down, allowing lock pin to unlock row-crop head. Repeat procedure on other side.
6. Raise hydraulic cylinder safety stop and hook chain.
7. Start engine and lower feeder house until row-crop head is on ground and attaching blocks are free.
8. Move combine slowly rearward until feeder house is clear of row-crop head.

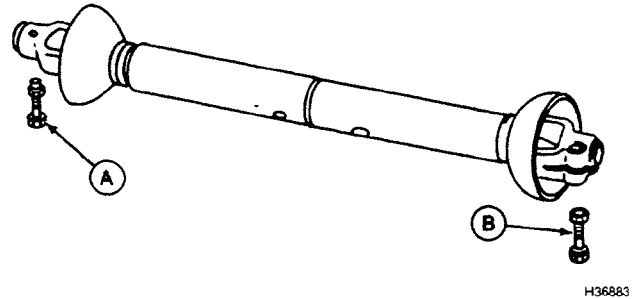

H36883



# Transporting

---

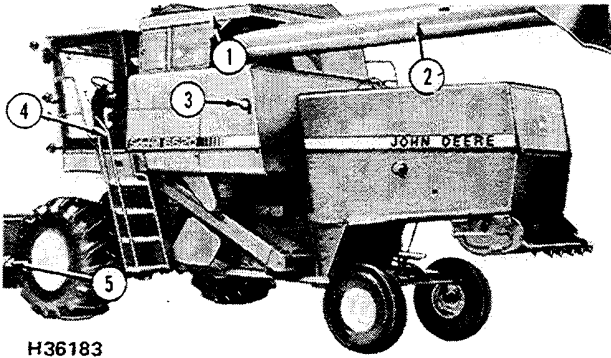

H36183

The row-crop head can be transported by leaving it attached to the combine.

1. Empty grain tank.
2. Swing unloading auger back.
3. Turn on combine flashing warning light, unless prohibited by local law.
4. Couple combine brake pedals together.
5. Raise row-crop head to a position that will keep it off the ground but still allow good visibility.
6. If transporting over rough terrain or extended distance, lock the row units in rigid position.



# Operating the Row-Crop Head

## GENERAL INFORMATION

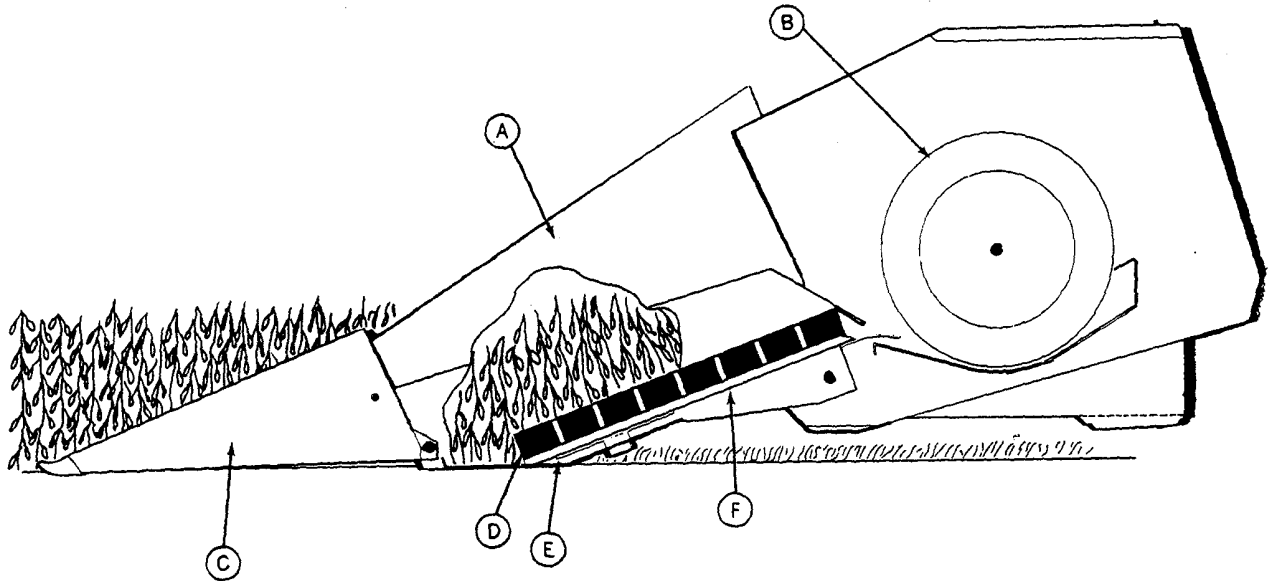

H26051

A—Outer Gatherer Sheet  
B—Auger

C—Outer Gatherer Point  
D—Gathering Belts

E—Rotary Knife  
F—Trough

The 50A Series Row-Crop Head is designed for harvesting soybeans, maize, and other row crops such as millet and sunflowers.

As the combine moves through the field, the row crop head gatherer points are positioned between the rows. Gatherer points lift and guide crop into the gathering belts.

The gathering belts extend forward of the rotary knife to grip each stalk before it is cut. After the rotary knives have cut the stalks, the gathering belts then convey them to the sump type auger. A trough, located under the gathering belts, reduces crop loss due to shatter. The auger conveys the crop to the feeder house which delivers it to the threshing cylinder.

It is important that gather belt speed be approximately the same as combine ground speed.

## DRIVE AND OPERATE CAREFULLY

When starting in the field, operate the combine or tractor in a lower gear until you become familiar with the row-crop head. Drive carefully, harvesting the crop rows as they were planted so it will not be necessary to cut odd or guess rows. Never force the row-crop head or combine to the point of overloading. Machine overloading can result in breakdowns.

After making several rounds, stop the row-crop head and shut off engine. Check all bearings for heating. All bolts must be tight and chains properly adjusted. Listen for slipping clutches or other unusual noises. If the row-crop head becomes plugged, clean it out. Do not decrease engine speed. Keep the engine operating speed and decrease the ground speed until the row-crop head has been cleared.

## ROW-CROP HEAD DRIVE SPEEDS

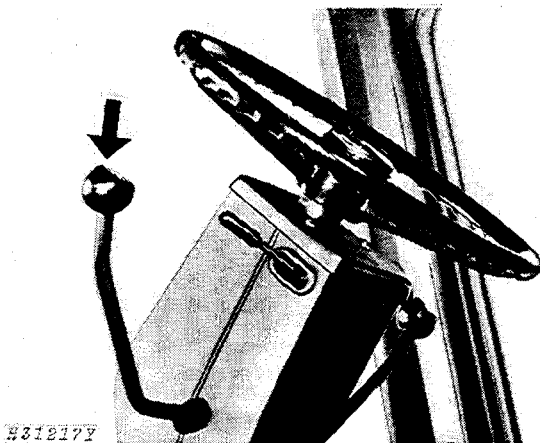

To prevent plugging or running over crop, the forward ground speed of the combine must be approximately the same as the rearward movement of the gathering belts. Row-crop head drive speed is varied by changing the speed of the lower feeder house shaft.

Adjust as follows:

1. On combines equipped with variable speed feeder houses, shaft speed ranges from approximately 460 to 720 R.P.M. Speed is controlled with the variable speed control lever.
2. On chain driven feeder houses, use one of three sprockets located on the lower left-hand side of the feeder house to vary the speed to one of three fixed speeds of 468, 618 and 755 R.P.M.

The following table may be used as a guide to match header speed to combine travel speed.

Combine travel speed	Approximate lower feeder house shaft speed
less than: 2.5 MPH	470 RPM
3. MPH	550 RPM
3.5 MPH	620 RPM
4. MPH	690 RPM
greater than: 4.5 MPH	750 PRM

## ADJUST ROW-CROP HEAD PROPERLY

Successful operation, quality of work, and length of life of any machine depends greatly upon proper adjustments to meet specific field conditions.

After making several rounds, check adjustments on the row-crop head and combine to see that you are getting the best possible crop sample in the grain tank.

## HYDRAULIC CYLINDER SAFETY STOP

1. **CAUTION:** When working under the row-crop head always place the hydraulic cylinder safety stop in safety position to prevent header from lowering.

Start engine, raise feeder house and fully extend hydraulic cylinder to place safety stop (A) in safety position.

2. Disconnect chain (B) from safety stop.
3. Position safety stop on piston rod.

After completing work on the row-crop head, attach safety stop to chain for storage.

A—Safety Stop  
B—Chain

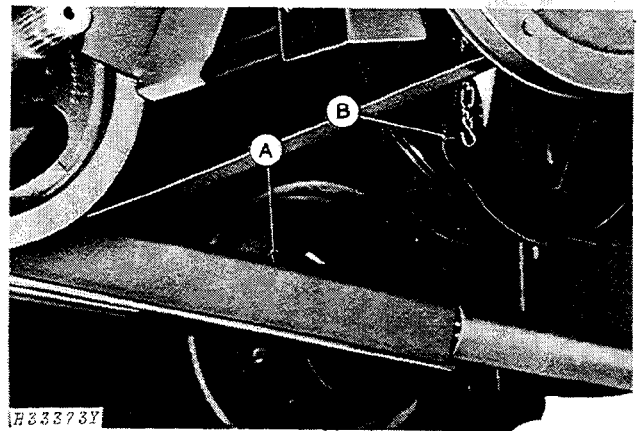

## GATHERERS

### General Information

Adjust point height clearance to prevent points from scooping dirt into gathering belts.

In standing soybeans, adjust gatherer point height for approximately 2 inches (51 mm) clearance from ground. In down crop conditions adjust point height for 1/2 to 1-inch (13 to 25 mm) clearance from the ground.

Adjust all gatherer points level with one another. On uneven terrain and with longer heads, it is often desirable to carry the end points slightly higher than others.

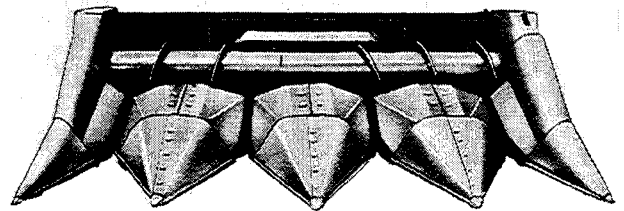

H33908Y



**Suggest:**

**If the above button click is invalid.**

**Please download this document**

**first, and then click the above link**

**to download the complete manual.**

**Thank you so much for reading**

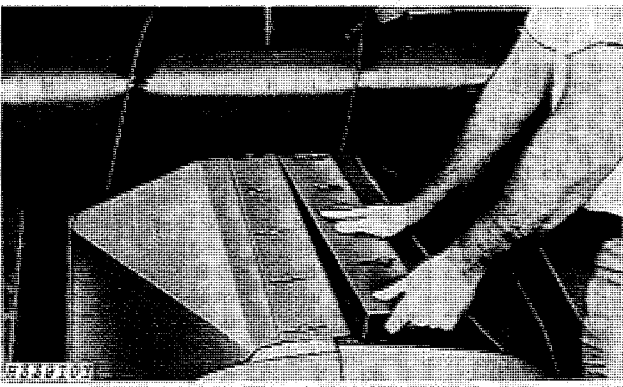
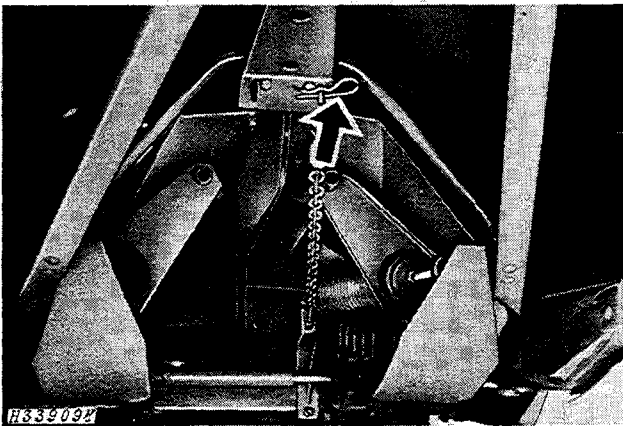

### Opening Inner Gatherer Sheets

1. Raise row-crop head to maximum height and lower hydraulic cylinder safety stop.
2. Pull spring locking pin attaching chain to point and lower point to ground. Store pin in same chain link to prevent loss and to retain adjustment location.

3. To open, pull up on inner gatherer sheets.
4. To close, push down on sheet until you hear it snap.

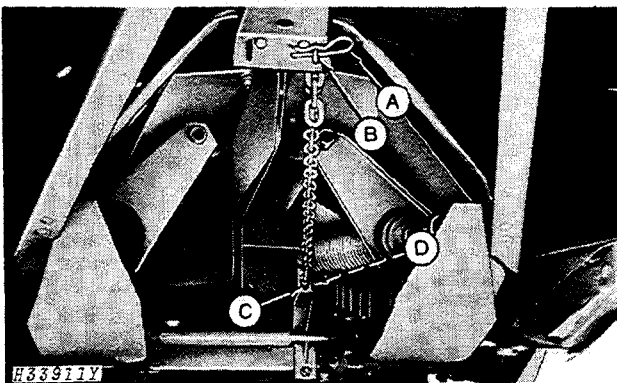

A—Spring Locking Pin  
B—Slot  
C—Nut  
D—Adjusting Bolt

### Adjusting Inner Gatherer Points Up Or Down

1. Raise row-crop head to maximum height and lower hydraulic cylinder safety stop.
2. Remove spring locking pin (A).
3. Position desired link of chain in slot (B).
4. Insert spring locking pin (A).

If further adjustment is required to level gatherer points adjust as follows:

1. Loosen nut (C).
2. Turn adjusting bolt (D) until desired height is obtained.
3. Tighten nut (C).

**<https://www.ebooklibonline.com>**

Hello dear friend!

Thank you very much for reading.

Enter the link into your browser.

The full manual is available for immediate download.

**<https://www.ebooklibonline.com>**