



To the Purchaser

This new row-crop head was carefully designed and manufactured to give years of dependable service. To keep it running efficiently, read the instructions in this operator's manual. Each section is clearly identified so you can easily find the information you need—whether it is operation, adjustments, lubrication, or service. Read the Table of Contents to learn where each section is located.

This manual includes information for 453, 454, 554, 653, 654, and 853 row-crop heads.

 This safety alert symbol identifies important safety messages in this manual. When you see this symbol, be alert to the possibility of personal injury and carefully read the message that follows.

Your operator's manual contains SI Metric equivalents which follow immediately after the U.S. customary units of measure.

"Right-hand" and "left-hand" sides are determined by facing in the direction the row-crop head will travel when in use.

Record your row-crop head serial number in the space provided on page 55. Your dealer needs this information to give you prompt, efficient service when you order parts. If your row-crop head requires replacement parts, go to your John Deere dealer where you can obtain Genuine John Deere parts—accept no substitutes.

The warranty on this row-crop head appears on your copy of the purchase order which you should have received from your dealer when you purchased the row-crop head.





Contents

	Page
Safety Suggestions2
Description3
Operation4
Lubrication.....	.26
Service27
Trouble Shooting.....	.35
Installing Row-Crop Head47
Removing Row-Crop Head.....	.52
Special Equipment.....	.53
Specifications54
Index.....	.56

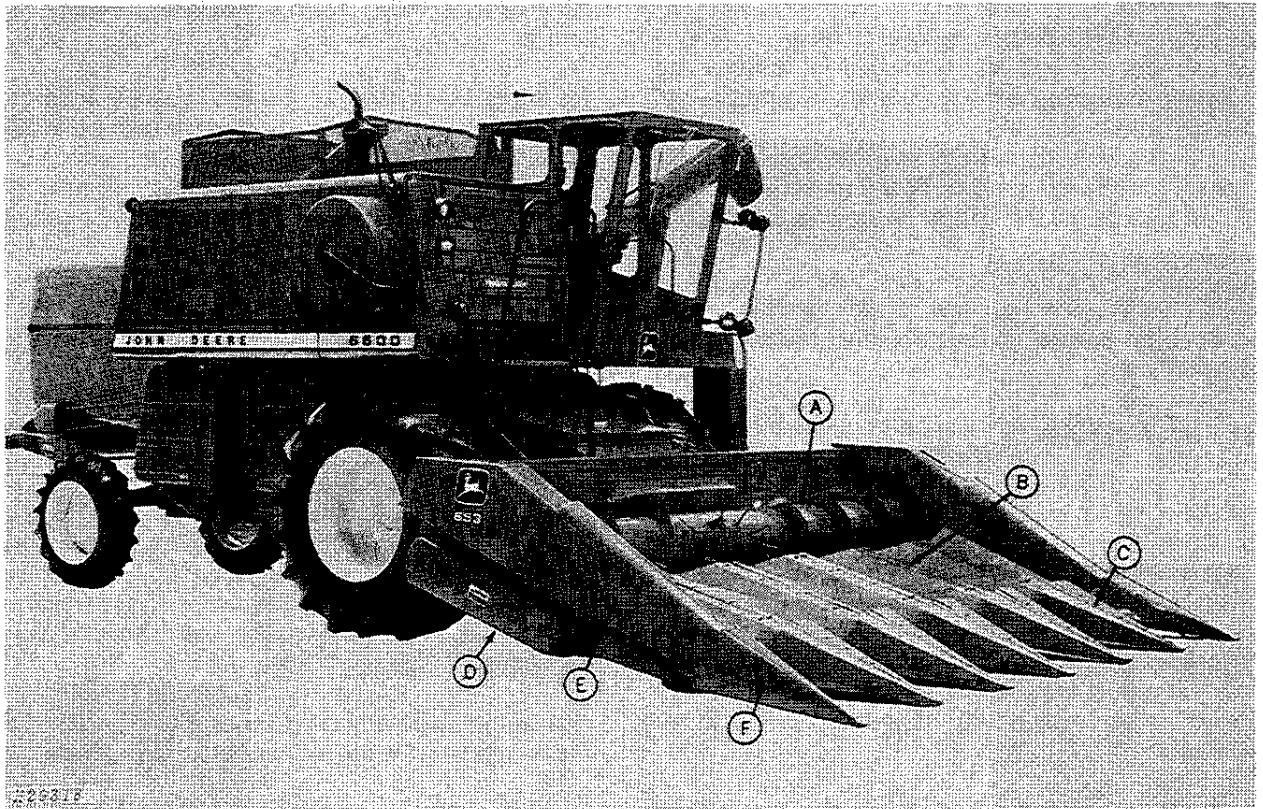

A—Cross Auger
B—Inner Gatherer Sheet

C—Inner Gatherer Point
D—Row Unit Drive Shield

E—Outer Gatherer Sheet
F—Outer Gatherer Point

653 Row-Crop Head on 6600 Combine

<https://www.ebooklibonline.com>

Hello dear friend!

Thank you very much for reading.

Enter the link into your browser.

The full manual is available for immediate download.

<https://www.ebooklibonline.com>



Safety Suggestions

⚠ Study these suggestions carefully and insist that they be followed by those working with you and for you.

The safety of the operator was one of the prime considerations in the minds of John Deere engineers when this row-crop head was designed.

All machinery must be operated only by responsible persons who have been delegated to do so.

Only the operator must be allowed on the operator's platform when the combine is in operation.

Never clean, lubricate, or adjust the row-crop head or combine while either is running or in motion. Keep hands and clothing away from all moving parts.

Clothing worn by operator must be fairly tight and belted. Loose jackets, shirts, or sleeves must never be worn because of the danger of getting into moving parts.

Everyone must be clear of the combine before starting the combine engine so no one can be struck by moving parts.

Shields and guards must be in place and in good condition before starting in field.

Escaping hydraulic fluid under pressure can have sufficient force to penetrate the skin, causing serious personal injury. Before disconnecting lines, relieve all pressure. Before applying pressure to the system, all connections must be tight and lines, pipes and hoses not damaged. Fluid escaping from a very small hole can be almost invisible. Use a piece of cardboard or wood, rather than hands, to search for suspected leaks.

If injured by escaping hydraulic fluid, see a doctor at once. Serious infection or reaction can develop if proper medical treatment is not administered immediately.

Never use a stick to clean the gathering belts of an obstruction while the row-crop head is running. If for any reason, the row-crop head should become clogged, stop the combine engine and remove the obstruction from the row-crop head.

Row units must be locked-out in the rigid operating position when transporting the row-crop head on roadways.

When transporting the row-crop head and combine on a road or highway at night or during the day, use lights and devices for adequate warning to operators of other vehicles. In this regard, check local governmental regulations.

Red reflective tape is attached to the rear of the outer gatherer sheets. Amber reflective tape is attached to the front of the left-hand main frame tube. When transporting the combine and row-crop head on a road or highway, reflective tapes must be clean and in place.

Provide a first aid kit for use in case of accident. Use proper antiseptics on scratches and cuts without delay to prevent the possibility of infection.

When the row-crop head is raised, never crawl under it until you have lowered the combine hydraulic cylinder safety stop and shut off engine. The cylinder safety stop prevents the row-crop head from lowering. To lower safety stop, first extend hydraulic cylinders. Disconnect support chain from safety stop and position safety stop on piston rod. After completing the work on the row-crop head, attach safety stop to support chain for storage.

If spray can paint is used, be careful when discarding empty can. Do not incinerate or puncture can.

Finally, remember this: An accident is usually caused by someone's carelessness, neglect, or oversight.



Description

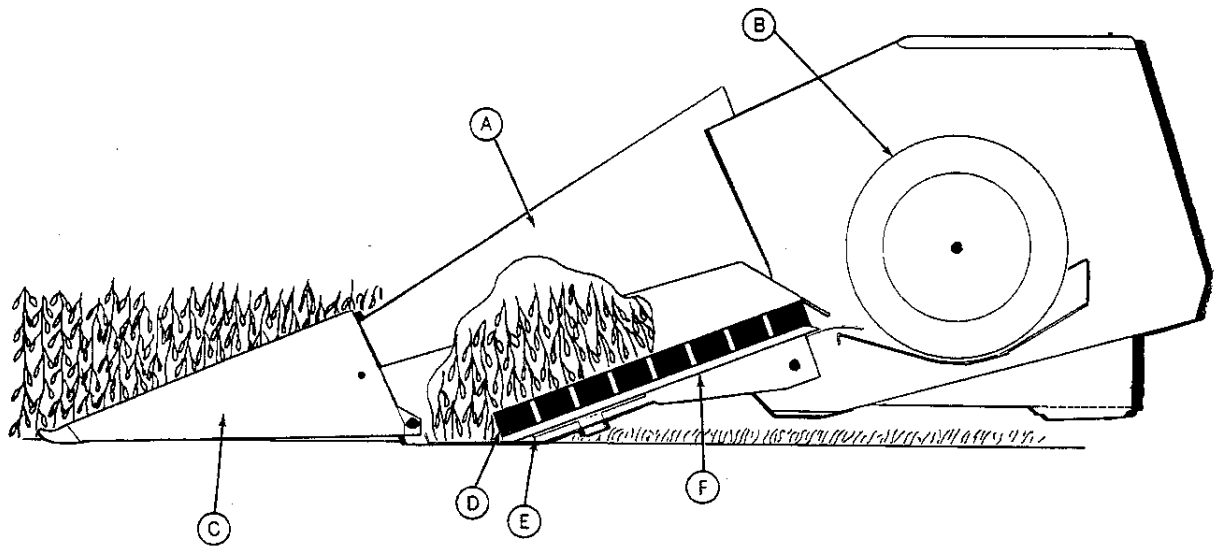

H26061

A—Outer Gatherer Sheet
B—Cross Auger

C—Outer Gatherer Point
D—Gathering Belts

E—Rotary Knife
F—Trough

GENERAL INFORMATION

The 50 Series Row-Crop Head is designed for harvesting soybeans and maize. The head can be used to harvest other row crops such as millet and sunflowers. It is not intended to be used as a corn harvester. Faster ground speeds and minimized crop losses are possible with the row-crop head.

As the combine moves through the field, the row-crop head gatherer points are positioned between the rows and under lodged and low-growing crops. These gatherer points lift and guide the crop gently into the gathering belts.

The gathering belts extend forward of the rotary knife to grip each stalk before it is cut, giving sure plant control before, during, and after cutting. Only the crop in the row is cut.

Each row unit has its own rotary knife, equipped with six high-carbon cutting sections. Every rotary knife operates at 1212 to 1986 cuts per minute. Because there is no vibration, faster ground speed is possible and shatter loss is minimized.

After the rotary knives have cut the stalks, the gathering belts then convey the stalks smoothly and gently to the sump-type cross auger. A trough, located under the gathering belts, reduces crop loss due to shatter.

It is important that the gather belt speed be approximately the same as combine ground speed.



Operation

ASSEMBLY AND INSTALLATION

Correct assembly and installation of the row-crop head on the combine will ensure long machine life and fewer service problems for you. After assembly and installation, check over the entire row-crop head, shields, sprockets, chains, and other parts must be properly attached.

See page 48 for INSTALLATION.

STARTING IN THE FIELD

Operate the combine in a lower gear until you become familiar with the row-crop head. Harvest the crop rows as they were planted so it will not be necessary to cut odd or guess rows.

After making several rounds, stop the row-crop head and shut off combine engine. Check all bearings for heating. All bolts must be tight and chains properly adjusted.

ADJUST ROW-CROP HEAD PROPERLY

Successful operation, quality of work, and length of life of any machine depends greatly upon proper adjustments to meet specific field conditions.

After making several rounds, check adjustments on the row-crop head and combine to see that you are getting the best possible crop sample in the grain tank.

Most field losses are caused by a careless operator who neglects to adjust his machine periodically. However, a few kernels lost does not call for numerous adjustments.

DRIVE AND OPERATE CAREFULLY

Drive the combine carefully so the row-crop head will stay on the rows. Never force the row-crop head or combine to the point of overloading. Machine overloading can result in breakdowns. Start out in a lower gear and increase speed until you find the proper ground speed in which to operate.

Listen for slipping clutches or other unusual noises. If the row-crop head becomes plugged clean it out, do not decrease combine engine speed. Keep the engine operating speed and decrease the ground speed until the row-crop head has been cleared.

IMPORTANT: The forward movement of the combine must be approximately the same as the rearward movement of the gathering belts or dirt ingestion and/or plugging can result.

A few minutes spent each day checking the row-crop head and the combine for proper adjustments will pay great dividends in service and long machine life as well as eliminating unnecessary field loss.

IMPORTANT: When transporting the combine or when removing the row-crop head, the float springs under the feeder house must be locked out.

GATHERERS

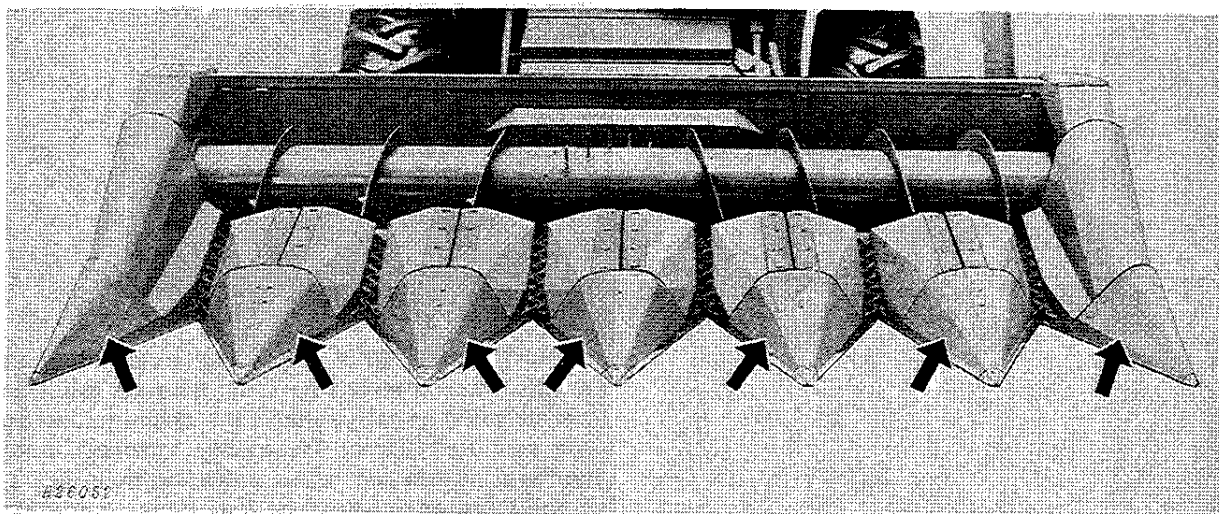

In standing soybeans, adjust gatherer point height for approximately 2 inches (51 mm) clearance from the ground. In down crop conditions, it may be necessary to adjust point height for 1/2- to 1-inch (13 to 25 mm) clearance from the ground.

Adjust point height clearance to prevent points from scooping dirt into the gathering belts. All points must be adjusted level with one another.

Adjusting Gatherer Points Up Or Down

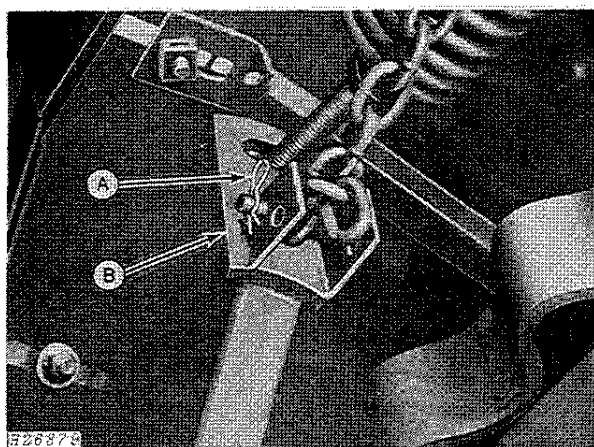

A—Locking Pin

B—Support Chain Bracket

CAUTION: Always lower the hydraulic cylinder safety stop when working under the row-crop head.

Raise row-crop head to maximum height and lower hydraulic cylinder safety stop.

To adjust gatherer points, remove spring locking

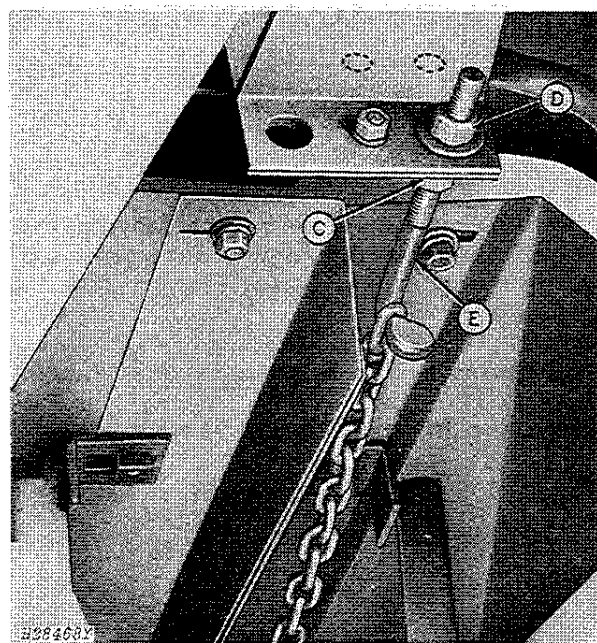

C—Nut

D—Nut

E—Adjusting Bolt

pin "A" and reposition pin in rear hole in support chain bracket "B".

To adjust the gatherer points further, loosen nut "C" and turn nut "D" for the desired operating height. Tighten nut "C."

NOTE: When operating the row-crop head in down and tangled maize, it may be desirable to further lower the center gatherer points, to get under and lift up the crop.

NOTE: Center gatherer points on wide 40-inch series may be lowered further to prevent them from going over center. Reposition the bolt "E" in the upper hole shown above with dotted lines.

Adjusting Outer Gatherer Points In Or Out

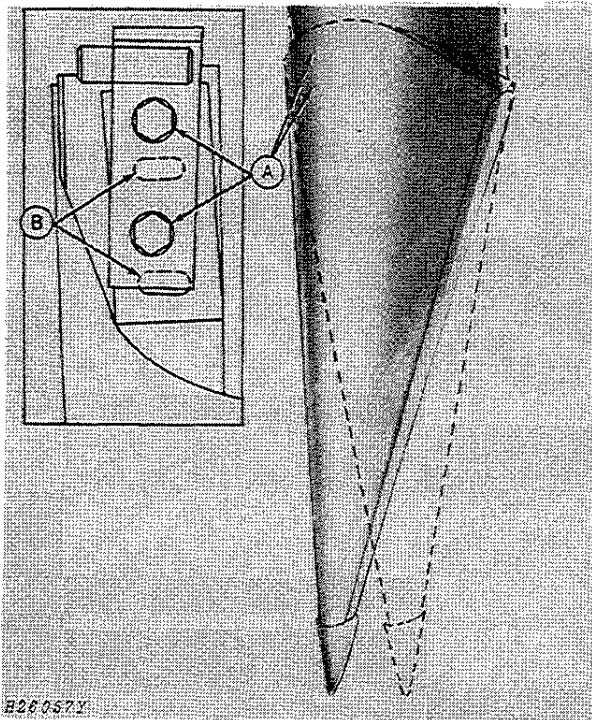

The outer gatherer points are attached to hinge pins at holes "A." In down crop conditions or when changing row spacing, it may be necessary to move the gatherer points in.

To move gatherer points, attach points at holes "B."

Removing Inner Gatherer Sheets

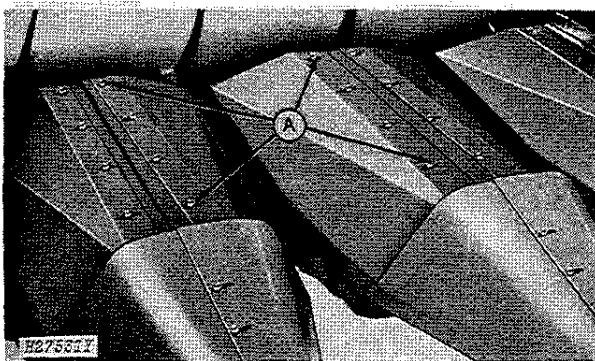

Remove the four bolts "A" and disengage gatherer sheet tabs to expose row unit.

CAUTION: Never operate row-crop head with gatherer sheets removed. Always install gatherer sheets after completing work on the row unit.

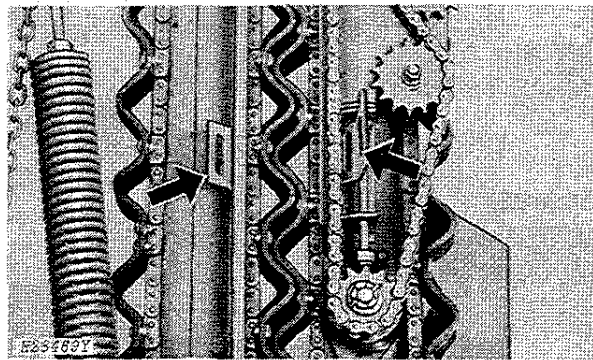

IMPORTANT: When replacing inner gatherer sheets after completing work, tabs on gatherer sheets must engage slots in the chain guides on the row unit frame. Incorrectly attached inner gatherer sheets can cause gathering belts to become worn or damaged or may cause gathering belts to jump out of time.

Tighten self-locking screws "A" to 13 ft-lbs (18 Nm) torque maximum. Do not overtighten.

Adjusting Gatherer Sheet Clearance

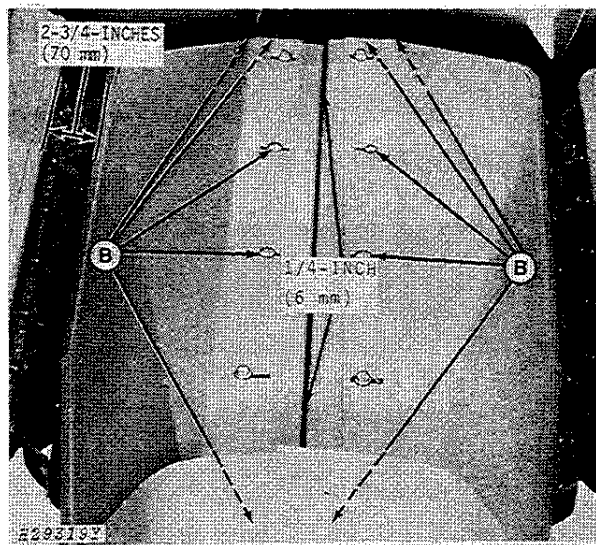

Tabs on gatherer sheets must engage slots in chain guides and 2-3/4 inches (70 mm) must exist between gatherer sheets (over the gathering belts).

A minimum clearance of 1/4-inch (6 mm) between gatherer sheets must be maintained to provide independent float of each row unit.

To obtain this 1/4-inch (6 mm) minimum clearance, loosen the ten screws "B" and slide gatherer sheets to the left or right.

IMPORTANT: Measure for this minimum distance at both upper and lower ends of the gatherer sheets.

ROW UNITS

Adjusting Row Units for Floating or Rigid Operation

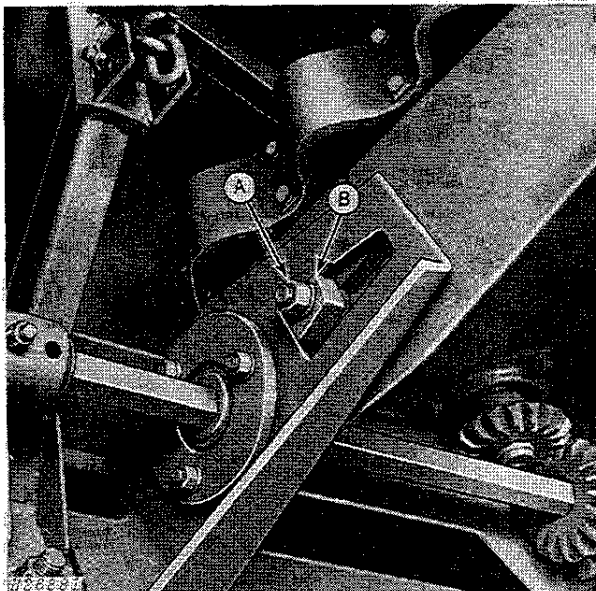

A—Nut B—Wedge

CAUTION: Always lower the hydraulic cylinder safety stop when working under the row-crop head.

Raise row-crop head to maximum height and lower hydraulic cylinder safety stop.

Floating Operation

On both sides of the row unit frame, loosen nut "A" and drive wedge "B" rearward for floating position. Row units must be adjusted for the floating position for soybeans.

Tighten nut "A."

Repeat this procedure for each of the row units.

Rigid Operation

On both sides of the row unit frame, loosen nut "A" and drive wedge "B" forward for rigid position. Row units must be adjusted for the rigid position for standing maize.

Tighten nut "A."

Repeat this procedure for each of the row units.

IMPORTANT: Row units must be locked in the rigid operating position when transporting the row-crop head.

Adjusting Row Unit Skid Shoes for Floating Operation

The row unit skid shoes can be adjusted to one of three positions, depending on the shape of the row hill and the height of the crop cut, to be able to achieve the desired cutting height.

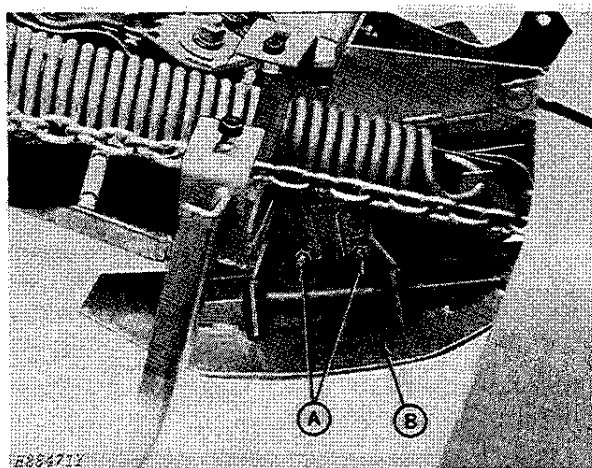

A—Nuts B—Skid Shoe

Illustrated in High Cut Position

CAUTION: Always lower the hydraulic cylinder safety stop when working under the row-crop head.

Raise row-crop head to maximum height and lower hydraulic cylinder safety stop.

Loosen nuts "A" and slide adjusting bolts out of slots.

Move skid shoe "B" up or down to the desired position.

Slide adjusting bolts back into slots and tighten nuts "A."

Repeat this procedure for each of the row units.

IMPORTANT: Before operating the row-crop head, clean the skid shoe bottoms thoroughly of dirt, rust, and paint to insure proper skid shoe float.

Adjusting Row Unit Float Spring Tension for Floating Operation

The row unit float springs must be properly tensioned for the existing ground conditions to be able to achieve minimum ground pressure on the skid shoes.

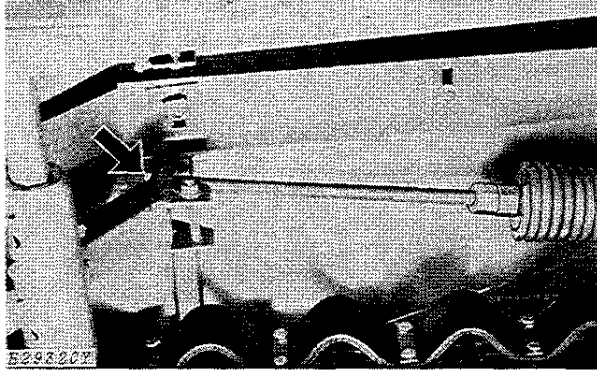

CAUTION: Always lower the hydraulic cylinder safety stop when working under the row-crop head.

Raise row-crop head to maximum height and lower hydraulic cylinder safety stop.

Loosen lock nut and turn spring tension adjusting bolt until the row unit begins to raise from the lower stop or until the row unit can be pushed upward easily. Tighten lock nut.

Row unit must then return freely against the lower stop. Repeat procedure for each of the row units.

NOTE: If for any reason the deck cover is removed, the weight of the cover must be taken into consideration when tensioning the springs.

Adjusting Gathering Belt Chain Tension

Gathering belt tension is maintained by an adjusting cam. This adjusting cam is provided to compensate for normal gathering belt chain wear. It must only be adjusted when the gathering belt chain is worn.

IMPORTANT: Gathering belt chains will wear during operation; therefore, it is necessary to tighten the chains periodically.

CAUTION: Always lower the hydraulic cylinder safety stop when working under the row-crop head.

Raise row-crop head to maximum height and lower hydraulic cylinder safety stop.

Loosen nut "A" and, using a suitable flat pry bar positioned against hex cam stud "B," force front idler forward until gatherer chain is tight.

Using a ratchet, tighten nut "A" to an initial 80 ft-lbs (110 Nm) torque before releasing pressure on pry bar.

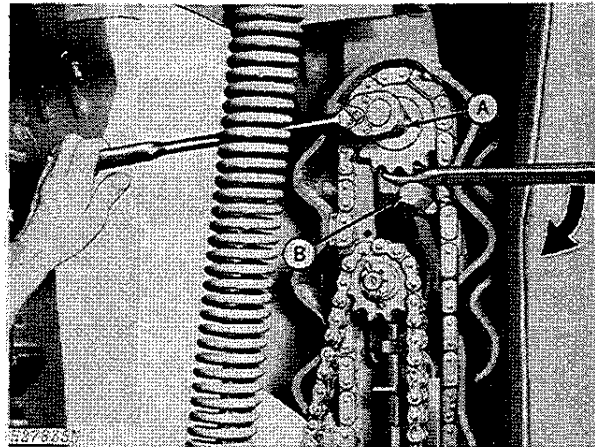

A—Nut B—Cam

Remove pry bar and then use both hands to tighten nut "A" to a minimum of 150 ft-lbs (205 Nm) torque. Nut "A" must be tightened to this specification or gathering belt chain will loosen during operation.

IMPORTANT: When operating the row-crop head in rocky field conditions, set skid shoes for a high cut and check the gathering belts and chains frequently for damage.

Timing Gathering Belts

To ensure proper gripping of crop stalks, the gathering belts must be kept in time. Whenever an obstruction is encountered, causing the slip clutch to slip, check for correct gathering belt timing.

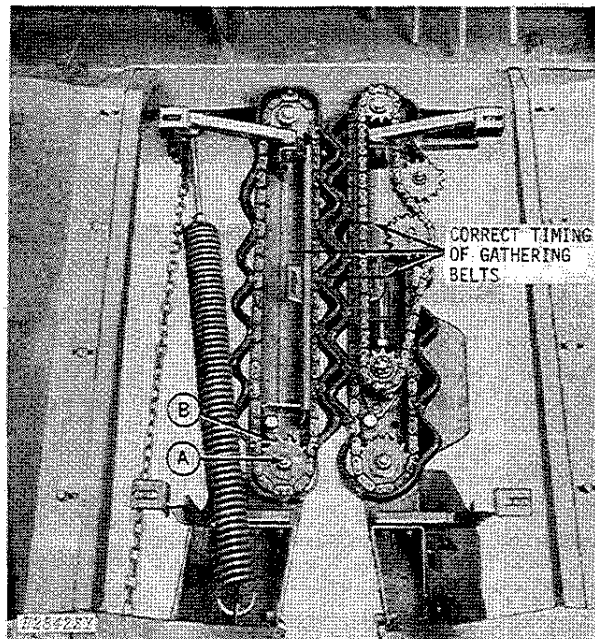

A—Nut B—Tightener

1. Remove gatherer sheet to time gathering belts. See page 6.

NOTE: It may be helpful with a new chain to remove the right-hand chain guide.

2. To time gathering belts, loosen nut "A" and remove chain from tightener "B."

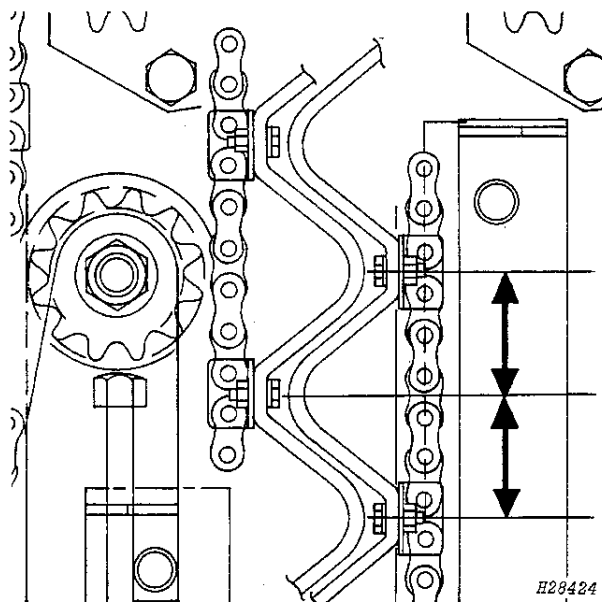

3. Position gathering belt so the lug attachment links on the right-hand belt are half-way between the lug attachment links on the left-hand belt. Bold arrows show equal distance.

4. Refer to the previous page for the correct procedure for adjusting gathering belt chain tension.

Removing Gathering Belt

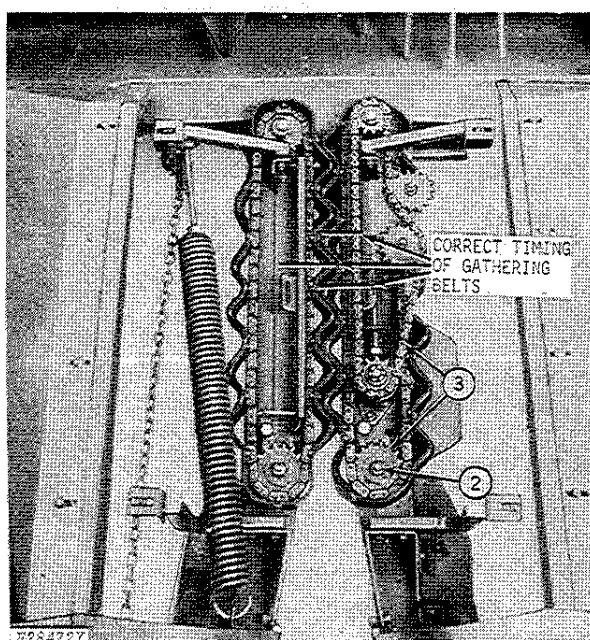

1. (Not illustrated.) Remove gatherer sheets. See page 6.

2. Remove nut and washer on idler.

3. Slide idler all the way back and lift idler off with chain.

4. (Not illustrated.) Set idler aside from chain.

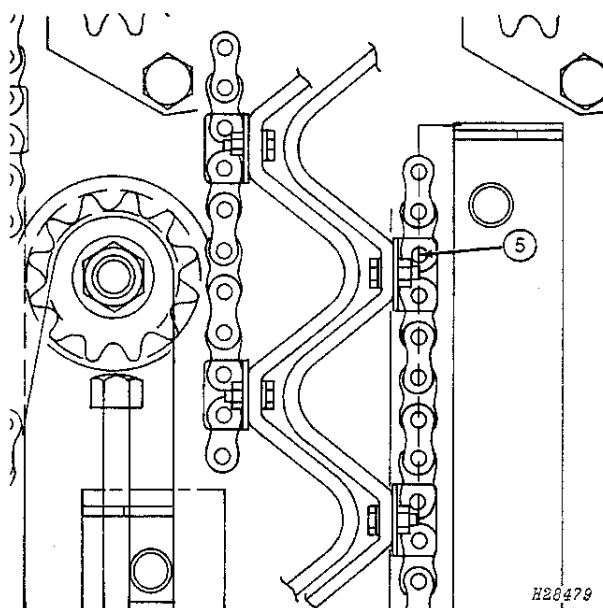

5. Remove chain on belt from chain guide by compressing belt away from metal edge.

6. (Not illustrated.) Lift chain with belt out.

7. Install in reverse order.



8. Connecting link must be up with trailing edge toward direction of travel shown with bold arrow.

Adjusting Range Indicator (Attachment) (Floating Row-Crop Heads Only)

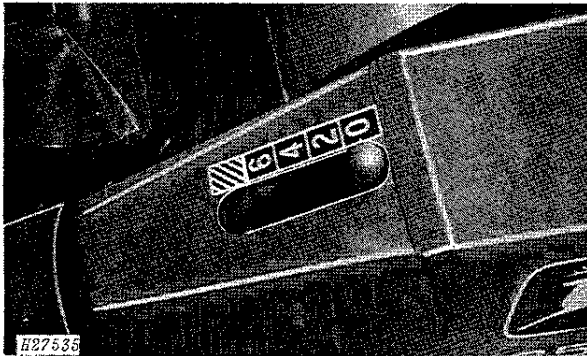

The float range indicator attachment, located on the left-hand side of the float row-crop head, lets the operator know at a glance where the row units are within their 6-inch (152 mm) float range. The numbers, located to the right of the red range indicator ball, indicate in inches the position of the **highest** row unit.

For example, if the indicator ball is on "6," the highest row unit is also at the bottom of the 6-inch (152 mm) float range. This would indicate to the operator to lower the header if the combine is not equipped with automatic header height control.

If the indicator ball is on "0," the highest of all the row units is at the top of the 6-inch (152 mm) float range. This would indicate to the operator to raise the header if the combine is not equipped with automatic header height control.

Normally, the red indicator ball should be positioned approximately on number "2," to achieve a low and consistent cutting height, with respect to the ground. For loose soil conditions or mud the "4" position may give better performance.

To adjust range indicator, raise row-crop head to maximum height and lower hydraulic cylinder safety stop.

CAUTION: Always lower the hydraulic cylinder safety stop when working under the header.

If combine is equipped with automatic header height control, be certain it is adjusted correctly (page 29).

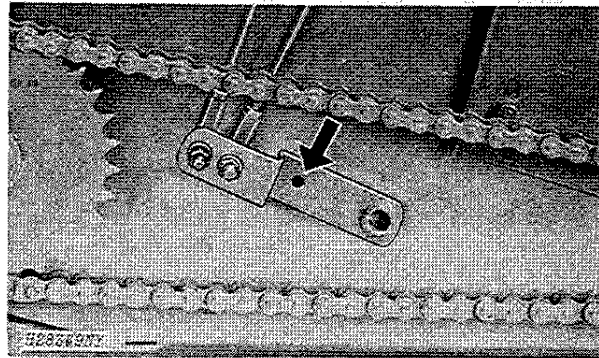

Align hole in lower actuator arm with matching hole in bulkhead. Secure arm in this position with pin.

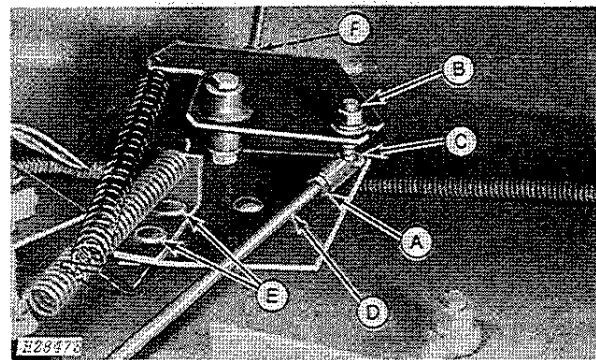

- A—Jam Nut
- B—Hex. Nut
- C—Ball Joint
- D—Push Rod
- E—Round Head Bolts
- F—Nut

Loosen jam nut "A," loosen hex. nut "B," and slip ball joint "C" out of slot.

Turn ball joint up or down on push rod "D" for adjustment. Slide ball joint back into slot. Red range indicator ball must be centered on "0" tab (zero) of decal.

Tighten hex. nut "B" and jam nut "A" after indicator ball is correctly centered. Remove pin from lower actuator arm and retain for future use.

Loosen nut "F" on ball shaft and position so ball is centered in slot. Tighten nut. See page 14.

IMPORTANT: Bellcrank under nut "F" must not bind against side sheet.

If row-crop head is not equipped with automatic header height control, remove the two round head bolts "E" and reposition spring bracket and spring as shown by dotted lines. Replace and tighten bolts "E."

NOTE: Spring bracket and spring, illustrated above, are shown on a row-crop head equipped with automatic header height control.

Raise hydraulic cylinder safety stop and lower row-crop head to ground.

Adjusting Rotary Knife Drive Chain Tension

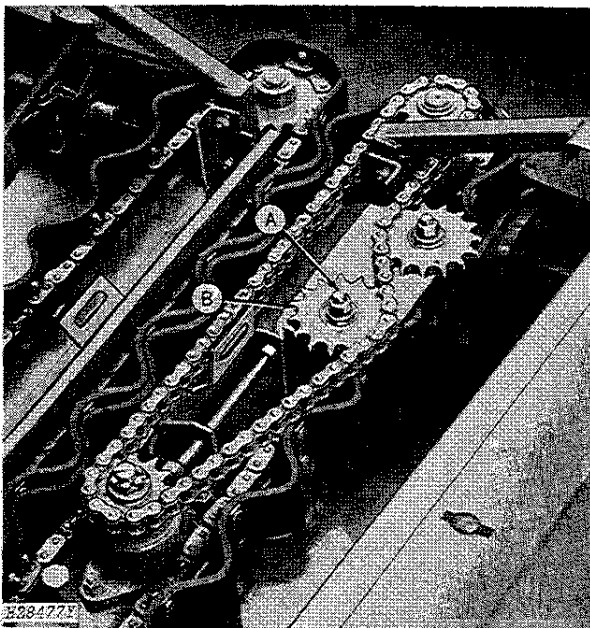

A—Nut B—Tightener

⚠ CAUTION: Always lower the hydraulic cylinder safety stop when working under the row-crop head.

Raise row-crop head to maximum height and lower hydraulic cylinder safety stop.

Loosen nut "A" and move tightener "B" until chain is tight enough to operate without climbing or jumping sprockets.

Tighten nut "A".

Adjusting Rotary Knives

When operating the row-crop head in adverse crop conditions, the rotary knives must be removed from the row units and thoroughly cleaned of solidified plant juices and trash, before they can be correctly adjusted to a good shear.

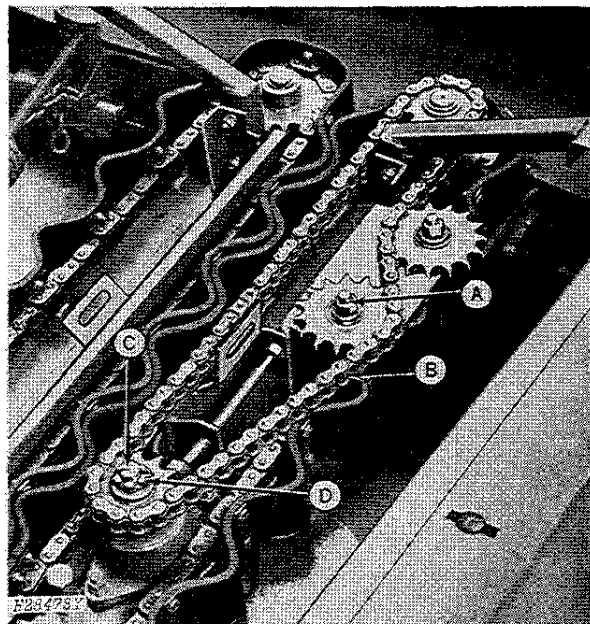

A—Nut C—Cotter Pin
B—Drive Chain D—Slotted Nut

⚠ CAUTION: Always lower the hydraulic cylinder safety stop when working under the row-crop head.

Raise row-crop head to maximum height and lower hydraulic cylinder safety stop.

To adjust rotary knife, loosen nut "A," slide tightener in, and remove rotary knife drive chain "B."

Remove cotter pin "C" and turn slotted nut "D" until the rotary knife can be turned by hand. A slight drag or shearing action must be felt as the rotary knife passes across the stationary knife. If the rotary knife cannot be turned by hand, then back off slightly on slotted nut "D." Replace cotter pin "C."

NOTE: When rotary knives are properly adjusted, they may become warm to the touch, but never hot after operation.

CROSS AUGER

Both sides of the row-crop head main frame and auger bearing carriers are slotted for adjusting the auger up and down and fore and aft.

Adjusting Auger Height

A 1/4 to 1/2-inch (6.4 to 12.7 mm) clearance between the auger flights and the bottom of the auger sump is required for most crops and conditions for smooth, even feeding.

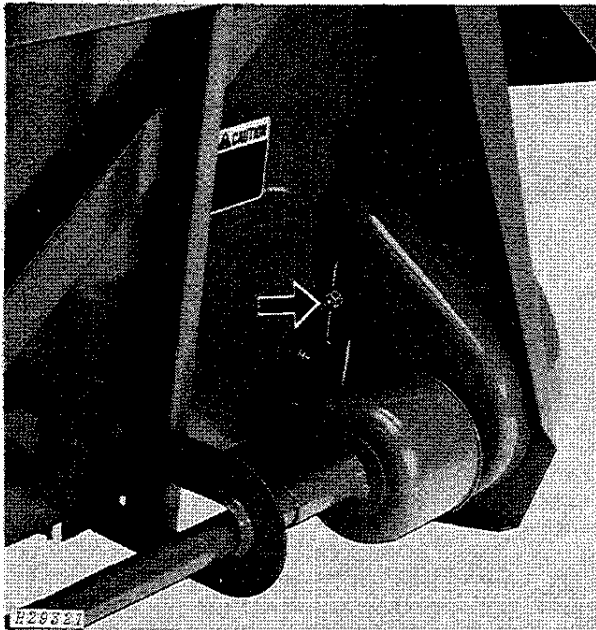

653 Row-Crop Head Illustrated

Loosen nut and move auger drive chain tightener up then tighten nut.

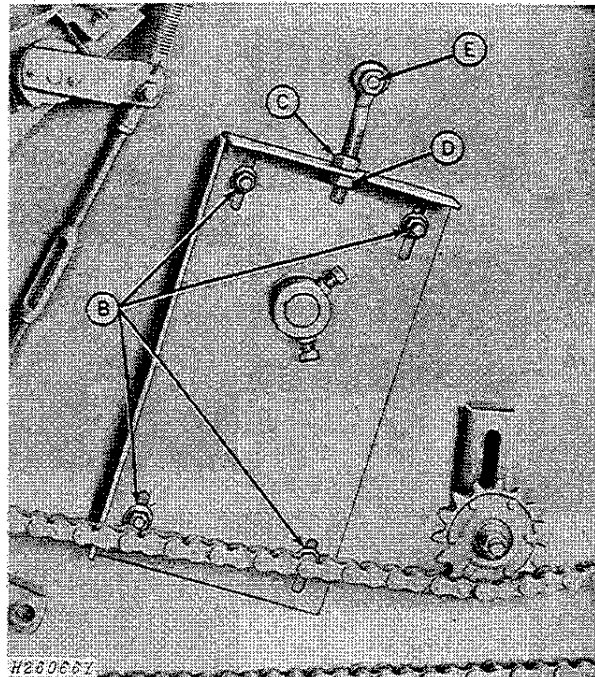

To raise auger, loosen nuts "B" and "C." Tighten nut "D" (both sides). Tighten nuts "C" and "B."

To lower auger, loosen nuts "B" and "D." Tighten nut "C" (both sides). Tighten nuts "D" and "B."

Adjust auger drive chain tightener "A" so chain will operate without climbing or jumping sprockets. Tighten nut.

Adjusting Auger Forward and Rearward

A 1/8-inch (3 mm) clearance between the auger flights and the auger stripper is required for most crops and conditions, for smooth, even feeding.

Loosen nut and move auger drive chain tightener "A" up.

Loosen nuts "B" and "E" and position auger for desired stripper clearance (both sides).

Tighten nuts "B" and "E."

Adjust auger drive chain tightener "A" so chain will operate without climbing or jumping sprockets. Tighten nut.



Suggest:

If the above button click is invalid.

Please download this document

first, and then click the above link

to download the complete manual.

Thank you so much for reading

ROW SPACING

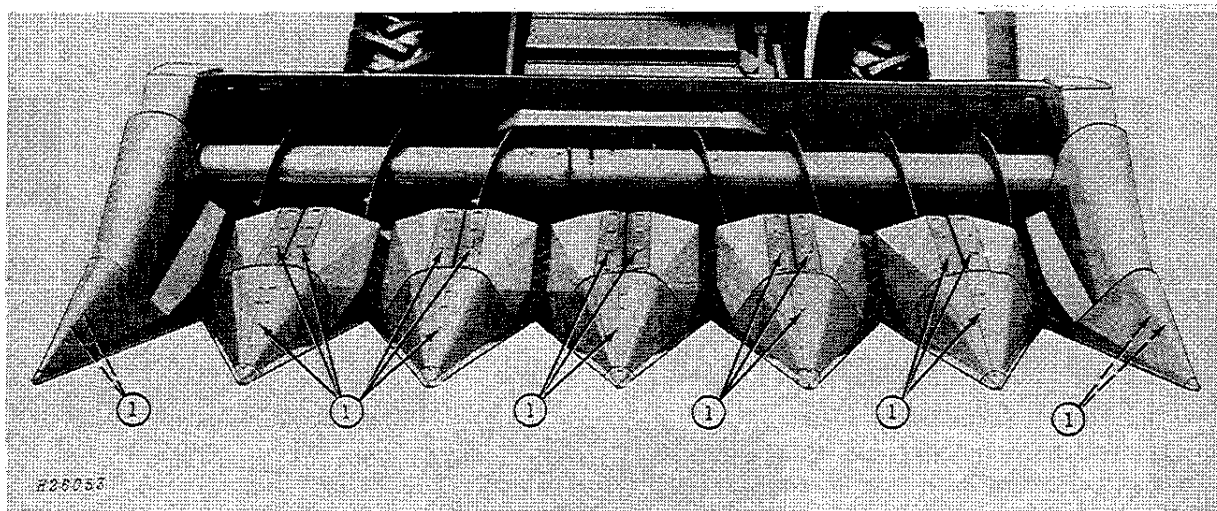

ROW SPACING

Row-Crop Head Model	Inches	(Millimetres)
453	28,30	(711,762)
454	36,38,40	(914,965,1016)
554	38,40	(965,1016)
653	28,30	(711,762)
654	36,38	(914,965)
853	28,30	(711,762)

CAUTION: Always lower the hydraulic cylinder safety stop when working under the row-crop head.

To change row spacing, the following steps must be performed:

1. Loosen all bolts attaching outer gathering sheets together. Loosen all inner gathering sheet adjusting bolts.

Release tension on each row unit float spring. See page 8.

2. Remove bolts securing center gatherer point supports together.

3. If row-crop head is equipped with automatic header height control, pull cotter pins and remove all height sensing actuating rods.

4. If the maize heads are down move the point support rod to the upper hole. This will prevent the divider point from going over center and allowing it to dig in the ground.

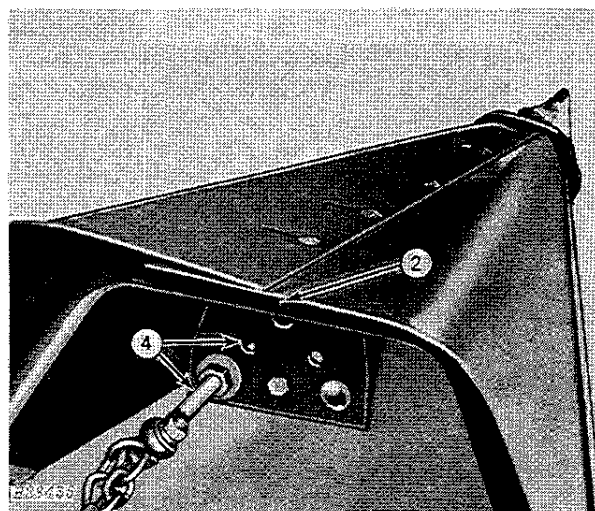

40-Inch Row Illustrated

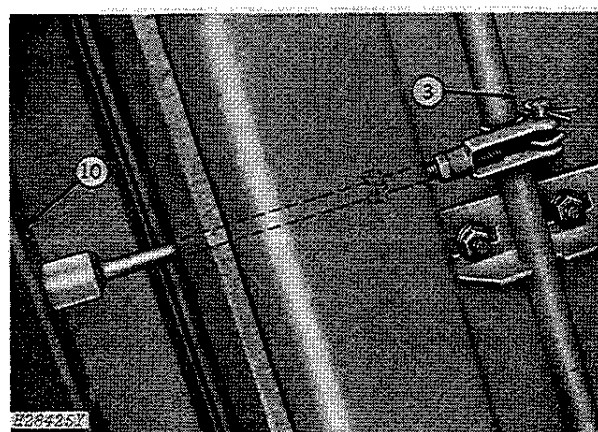

<https://www.ebooklibonline.com>

Hello dear friend!

Thank you very much for reading.

Enter the link into your browser.

The full manual is available for immediate download.

<https://www.ebooklibonline.com>