

**JOHN DEERE**  
**WORLDWIDE COMMERCIAL & CONSUMER**  
**EQUIPMENT DIVISION**

---

**Front Mount Blade**  
**48 Inch**

**OMM153332 G5**

**OPERATOR'S MANUAL**



**JOHN DEERE**

All information, illustrations and specifications in this manual are based on the latest information at the time of publication. The right is reserved to make changes at any time without notice.

**COPYRIGHT© 2005**  
Deere & Co.

John Deere Worldwide Commercial and Consumer Equipment Division  
All rights reserved  
Previous Editions  
**COPYRIGHT©**

North American Version  
Litho in U.S.A.

# INTRODUCTION

## Introduction

### Using Your Operator's Manual

This manual is an important part of your machine and should remain with the machine when you sell it.

Use the safety and operating information in the attachment operator's manual along with the machine operator's manual to operate and service the attachment safely and correctly.

Specifications and design are subject to change without notice.

## Product Identification

### Product Compatibility

The 48-Inch Front Blade is compatible with the X500 Multi-Terrain™ Series Tractors

### Record Identification Numbers

48-Inch Front Blade Serial No. (010001 - )

If you need to contact an Authorized Service Center for information on servicing, always provide the product model and serial number.

You will need to locate the model and serial number for the machine and record the information in spaces provided below.

DATE OF PURCHASE:

DEALER NAME:

DEALER PHONE:

## Safety Labels

### Understanding The Machine Safety Labels

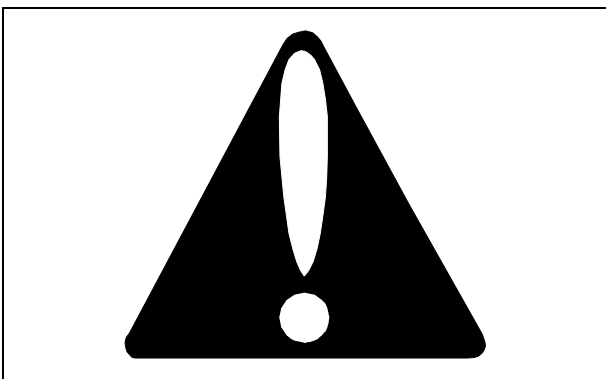

Safety-Alert Symbol

The machine safety labels shown in this section are placed in important areas on your machine to draw attention to potential safety hazards.

On your machine safety labels, the words DANGER, WARNING, and CAUTION are used with this safety-alert symbol. DANGER identifies the most serious hazards.

The operator's manual also explains any potential safety hazards whenever necessary in special safety messages that are identified with the word, CAUTION, and the safety-alert symbol.

## DANGER

### JAMMED BLADE CAN RETURN SUDDENLY



M119672

- Control spring force before removing jam

## CAUTION

### HELP AVOID INJURY FROM SUDDEN STOPS



M118227

- Keep spring trip unlocked except for slow speed heavy digging and grading
- On machines with hydraulic down pressure operate with blade in float position except for slow speed digging
- Use rubber scraper blade for high speed operation

## Safety

Read the general safety operating precautions in your machine operator's manual for additional safety information.

### Operating Safely

- This attachment is intended for light duty moving of snow or other light, loose material. Do not misuse this equipment.
- Read, understand and follow all instructions in the manual and on the vehicle and attachment before operating.
- Only allow responsible adults who are familiar with the instructions to operate the machine.
- Inspect machine and attachment before you operate. Be sure hardware is tight. Repair or replace damaged, badly worn or missing parts. Be sure guards and shields are in good condition and fastened in place. Make any necessary adjustments before you operate.
- Check brake action before you operate. Adjust or service brakes as

# ASSEMBLY

necessary.

- Stop machine if anyone enters the area.
- If you hit an object, stop and inspect the machine. Make repairs before you operate. Keep machine and attachments properly maintained and in good working order.
- Before operating, make sure all connections are tight and blade responds properly to controls. Check all connections periodically for tightness.
- Do not leave machine unattended when it is running.
- Only operate during daylight or with good artificial light.
- Be careful of traffic when operating near or crossing roadways.
- Do not wear radio or music headphones while operating the machine. Safe operation requires your full attention.
- Transport the blade with it raised to the highest position.
- Be aware of the position of the blade ends. Blade makes a wide arc when turning.
- Be aware of the possibility of objects hidden under the snow. Avoid holes, rocks, roots and other obstructions.
- Avoid the edges of ditches and banks to reduce the possibility of loss of control.
- When plowing material into a pile, travel in reverse before raising blade.
- Do not ram into a pile of material; slow down before contact is made.
- Lower attachment completely before leaving operator's seat.
- Lower any attachment completely to the ground or to an existing attachment mechanical stop before servicing the attachment. Disengage all power and stop the engine. Lock park brake and remove the key.
- Keep all parts in good condition and properly installed. Fix damage immediately. Replace worn or broken parts. Replace all worn or damaged safety and instruction decals.

## Parking Safely

1. Stop machine on a level surface, not on a slope.
2. Lower attachments to the ground.
3. Lock the park brake.
4. Stop the engine.
5. Remove the key.
6. Wait for engine and all moving parts to stop before you leave the operator's seat.
7. Close fuel shut-off valve, if your machine is equipped.
8. Disconnect the negative battery cable or remove the spark plug wire (for gasoline engines) before servicing the machine.

## Checking Area to be Cleared

- Thoroughly inspect the area where the equipment is to be used and remove all doormats, sleds, boards, wires and other foreign objects.
- Keep people and pets out of the work area. Keep children indoors when using blade. Turn the machine off if anyone enters the area.
- Be extremely careful if you must clear snow from a gravel surface. Adjust the blade height to clear a gravel surface.

## Avoid Injury From Hitting Obstructions

- Raise attachment when you drive between jobs.

- Slow down when you remove snow. Be cautious on slopes, when you make turns or when close to buildings or trees.

## Assembly

### Identify Parts

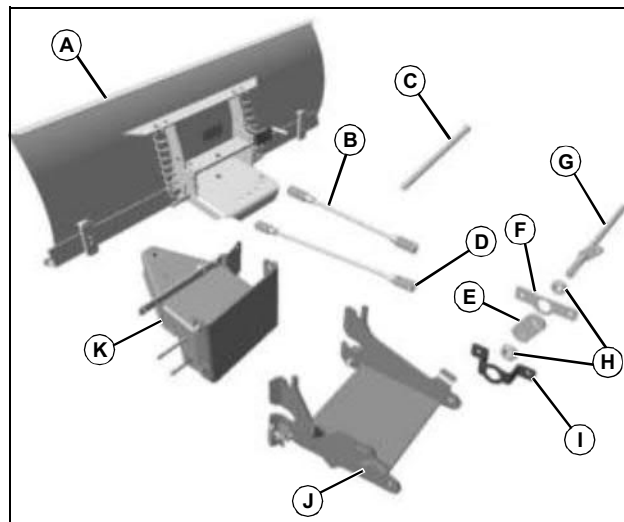

MX35652

- A - Blade Assembly**
- B - Lift Rod, Inner**
- C - Front Draft Pin**
- D - Lift Rod, Outer**
- E - Bracket, Rockshaft**
- F - Bracket, Support**
- G - Rockshaft**
- H - Bearing (2) (In bag of parts)**
- I - Plate, Mounting**
- J - Hitch, Front Attachment**
- K - Blade Support**

### Parts in Bag

Qty.	Description
2	Gage Wheel
2	Spring Locking Pin, 2.5 x 61.5 mm
1	Spring Locking Pin, 4.5 x 90 mm
2	Spring Locking Pin, 2.5 x 44 mm
2	Skid Shoe
2	Drilled Pin, Small, 9.4 x 25.4 mm

### Attaching Parts Bag

Qty.	Description
4	Drilled Pin, 10 x 28 mm
4	Locking Ring
1	Clevis Pin, 6 x 40 mm

**<https://www.ebooklibonline.com>**

Hello dear friend!

Thank you very much for reading.

Enter the link into your browser.

The full manual is available for immediate download.

**<https://www.ebooklibonline.com>**

**<https://www.ebooklibonline.com>**

Hello dear friend!

Thank you very much for reading.

Enter the link into your browser.

The full manual is available for immediate download.

**<https://www.ebooklibonline.com>**

# PREPARING VEHICLE

Qty.	Description
1	Cotter Pin, 2.5 x 16 mm
1	Cotter Pin, 3.2 x 32 mm
1	Cotter Pin, 2.5 x 20 mm
1	Capscrew, 3/4 x 5-1/2 in.
2	Nut, Jam, 3/4 in.
1	Bushing, Flange
1	Bolt, Flange, M10x30
1	Nut, Flange, M10

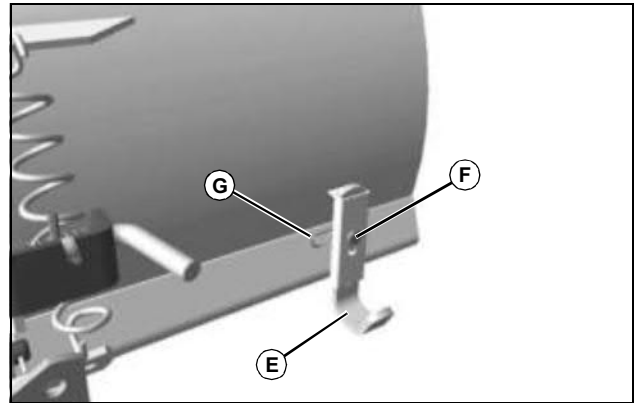

MX35657

3. Install each skid shoe (E) with small 9.4 x 25.4 mm drilled pin (F) and 2.5 x 61.5 mm spring locking pin (G).

## Assemble Front Blade

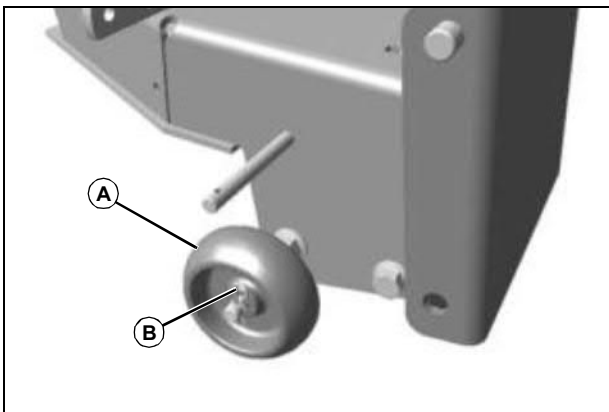

MX35655

1. Install gage wheel (A), one on each side of blade support and fasten with 2.5 x 44 mm spring locking pin (B).

**NOTE:** Jam nuts (D) should be installed back to back.

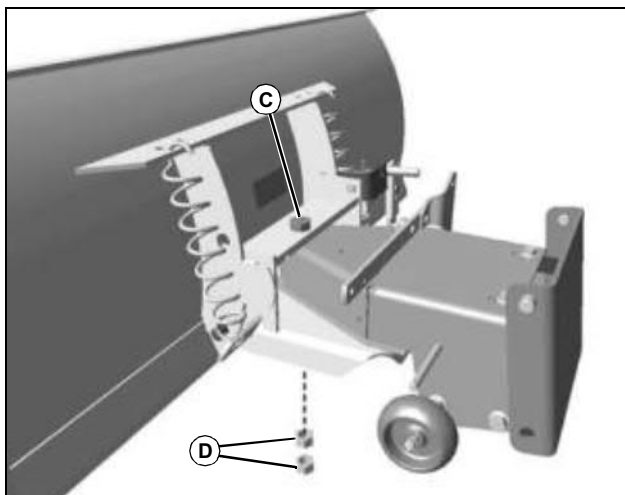

MX35656

2. Fasten blade support to blade with 3/4 x 5-1/2 in. capscrew (C) and two 3/4 in. jam nuts (D).

## Preparing Vehicle

### Remove Mower

1. Remove mower deck.
2. Remove drive belt from machine and store with mower deck.

### Install Rockshaft Assembly

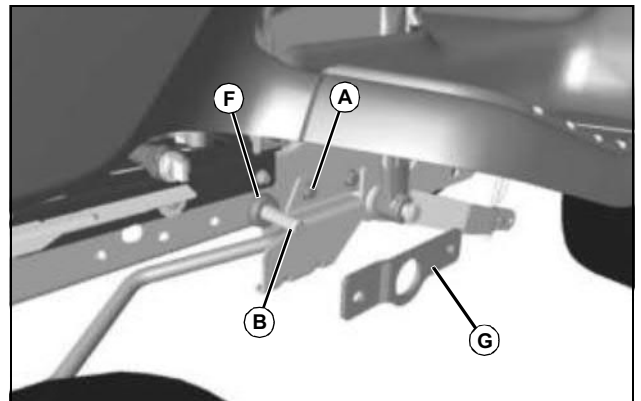

MX35614

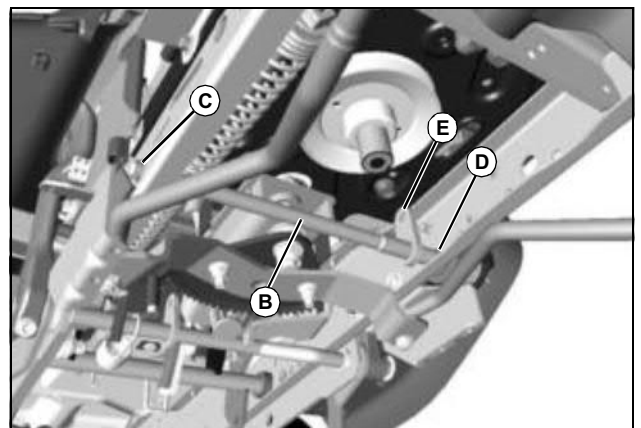

MX35724

1. Remove bolt (A) and nut under left side of fenderdeck.



**Suggest:**

**If the above button click is invalid.**

**Please download this document**

**first, and then click the above link**

**to download the complete manual.**

**Thank you so much for reading**

# INSTALLING

2. Install small end of rockshaft (B) through hole (C) on right side of machine frame, then pull large splined end through hole (D) on left side of machine frame. Make sure bracket (E) on rockshaft is pointing up.
3. Install one bearing (F) on end of shaft, with flange end of bearing against machine frame.
4. Install support bracket (G) on end of shaft.

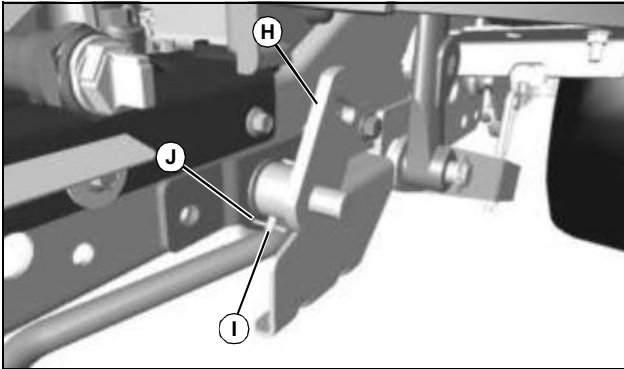

MX35615

5. Install rockshaft bracket (H) facing upward, as shown. Secure with 6 x 40 mm clevis pin (I) and 2.5 x 16 mm cotter pin (J).

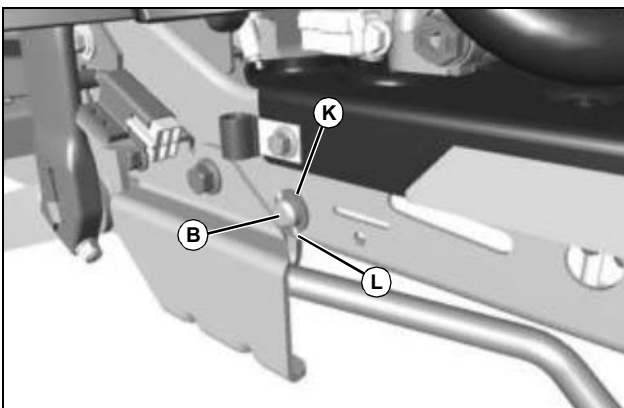

MX35645

6. Secure right side of rockshaft (B) with bushing (K) and 2.5 x 20 mm cotter pin (L).

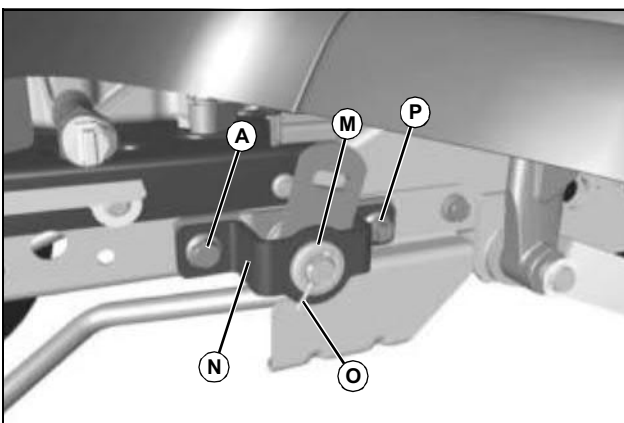

MX35644

7. Install second bearing (M) onto mounting plate (N), and install assembly onto shaft. Secure with 3.2 x 32 mm cotter pin (O).
8. Secure front side of assembly with bolt (A) and nut removed earlier.

9. Secure rear side of assembly with M10x30 flange bolt and M10 flange nut (P).

## Recommended Attachments



**CAUTION: Avoid injury! The machine may become unstable when operating on slopes and/or with some attachments.**

**Use weights to improve stability when operating on slopes or using attachments.**

**Remove weights when not required.**

## Recommended Attachments

See your John Deere dealer for the following attachments.

- Rear Tire Chains: Improves traction in snow and ice. (See machine operator's manual)
- Weights: Improves traction in all conditions. (See machine operator's manual)
- Bar Tires: For dirt applications.
- Remote Angling Kit: Allows angling of blade from machine seat.
- Rubber Squeegee Kit: Prevents scratching and improves cleaning.

## Check Tire Pressure

**IMPORTANT: Avoid damage! To prevent tire damage, do not use more than maximum tire pressure shown on sidewall of tire.**

**NOTE: See your Machine Operator's Manual for correct tire pressure.**

Check tire pressure with an accurate gauge.

Add or remove air, if necessary.

## Installing

### Install Lift Assembly



**CAUTION: Avoid injury! Lift pedal is spring-assisted and may have unexpected movement. Lock lift pedal when installing or removing attachment.**

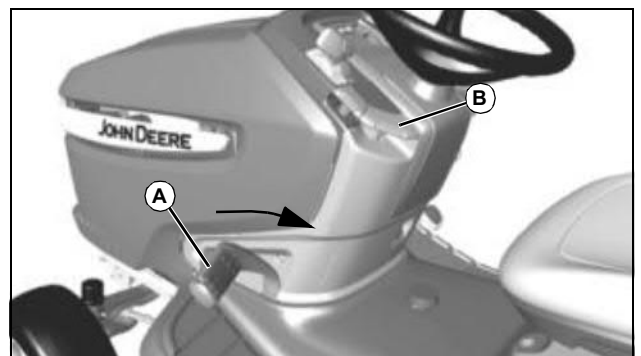

MX35646

1. Lower attachment linkage:

- For foot lift: Pull lift pedal (A) back by hand to lower linkage to the lower/down position. Pull lock lever (B) up to lock linkage in the lowered position.