

45 Self-Propelled Combines (Serial No. 45-16401 and up)



JOHN DEERE

OPERATORS MANUAL

45 Self-Propelled Combines (Serial No.
45-16401 and up)

OMH451158 K8 English

OMH451158 K8

LITHO IN U.S.A.
ENGLISH



TO THE PURCHASER

The combine you have just purchased was designed and manufactured to the traditionally high quality standards of all John Deere Farm Equipment. Your combine has been thoroughly inspected and tested not only at the factory but at your dealer's by a trained John Deere Serviceman. We are confident that you will receive years of dependable, economical service from your John Deere Combine.

STUDY THIS MANUAL CAREFULLY,
KEEP IT HANDY, IN A SAFE PLACE,
FOR FUTURE REFERENCE.

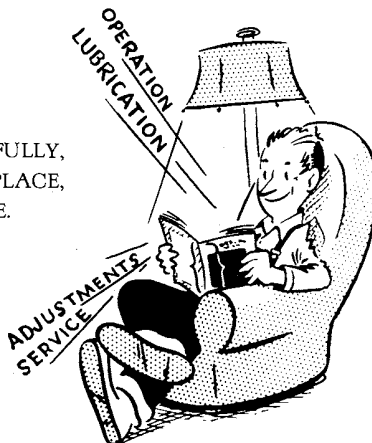

56847

If you should find that you require information not covered in this manual, consult your John Deere dealer. He will be glad to answer any questions that may arise regarding the operation and handling of the combine. He has trained mechanics who are kept informed on the best methods of John Deere Combine servicing and can give you prompt know-how service in the field or in his shop.

KEEP YOUR COMBINE A JOHN DEERE COMBINE

Genuine John Deere parts fit properly and insure satisfactory service because they are made from the original patterns and from the same materials as used in new machines. Should your combine require replacement parts, go to your John Deere dealer where you can obtain Genuine John Deere Parts—**accept no substitutes.**

LOCATION REFERENCE

“Right-hand” and “left-hand” sides are determined by facing in the direction the combine will travel when in use.

“Clockwise” refers to parts turning to the right like the hands of a clock. “Counter-clockwise” refers to parts turning to the left.

Engine Reference Only. Timing gear end of engine is referred to as the “front”; flywheel end as the “rear.”

SERIAL NUMBERS

Your combine, engine, cutting platform and axle are provided with serial numbers.

When ordering parts, always bring with you the model and serial numbers as given on the serial number plates. By doing so, you will assist your John Deere dealer in giving you prompt, efficient service.

Record the serial numbers in the spaces provided below. It is a good plan to copy the serial numbers down on a card to be carried in your bill-fold for quick reference.

The combine serial number is stamped on a plate located on the support bracket at the rear end of the fuel tank.

The engine serial number is stamped on a plate located on top of the fly-wheel housing.

The cutting platform serial number is stamped on a plate located on the outside of the right-hand platform divider.

The axle serial number is stamped on the top, left-hand end of the axle tube.

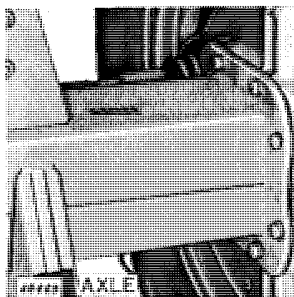

Axle Serial No.....

Combine Serial No.....

Platform Serial No.....

Engine Serial No.....

Date Purchased.....

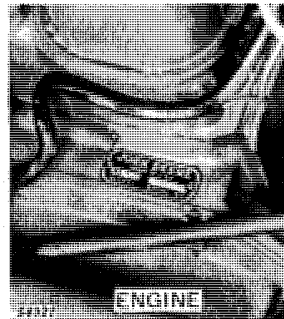
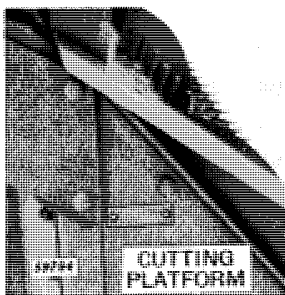

<https://www.ebooklibonline.com>

Hello dear friend!

Thank you very much for reading.

Enter the link into your browser.

The full manual is available for immediate download.

<https://www.ebooklibonline.com>

TABLE OF CONTENTS

	<i>Page</i>
SERIAL NUMBERS.....	1
GENERAL VIEWS.....	4
SPECIFICATIONS.....	7
LUBRICATION.....	13
COMBINE CONTROLS.....	28
OPERATOR'S SEAT.....	31
OPERATOR'S PLATFORM HINGED LADDER.....	32
OPERATION.....	33
Breaking In the New Combine.....	33
Engine Break-In.....	33
Before Operation Checks and Adjustments.....	34
Starting the Engine.....	34
Stopping the Engine.....	35
Starting the Combine.....	35
Selecting Proper Ground Speed.....	35
Transporting.....	36
Drive Wheel Tread.....	38
Slip Clutches.....	40
Basic Settings Made at the Factory.....	41
Cross-Sectional View of the 45 Combine.....	42
Safety Suggestions.....	44
Fundamentals of Combine Harvesting.....	46
Operating Suggestions.....	47
Corn Combining Suggestions.....	50
Suggested Setting for Combining Various Crops.....	56
Cold Weather Operation.....	64
Care When the Season Is Over.....	66
Care at the Beginning of the Next Season.....	68
ADJUSTMENTS AND SERVICE.....	69
Reel.....	69
Cutter Bar.....	76
Cutting Platform Auger.....	79
Feeder Conveyor.....	83
Cutting Platform Drive Throw-Out Mechanism.....	84
Loop Dividers and Adjustable Divider Points.....	85
Cutting Platform Lifting Mechanism.....	86
Cutting Platform Leveling Adjustment.....	87

TABLE OF CONTENTS—Continued

	<i>Page</i>
Cutting Platform Special Equipment.....	88
Cylinder and Concave Grate.....	94
Feed Rolls Attachment.....	109
Grain Conveyor.....	110
Cleaning Unit.....	113
Cleaning Fan.....	113
Chaffer and Sieve.....	117
ScourKleen.....	122
Shoe Pitmans.....	123
Straw Walkers.....	124
Clean Grain and Tailings Elevator.....	125
Grain Tank Unloading Auger.....	129
Hydraulic System.....	130
Separator Drive.....	131
Selective Ground Speed Control.....	133
Clutch.....	136
Brakes.....	137
Transmission.....	138
Straw Spreader.....	139
Straw Chopper.....	140
Care of Rubber Tires.....	141
Toe-In Adjustment.....	142
Steering Mechanism.....	143
Lighting Attachment.....	144
Care of Chains and V-Belts.....	146
Service Chart.....	150
ENGINE SERVICE.....	156
Fuel System.....	156
Governor.....	159
Ignition System.....	161
Starting System.....	164
Cooling System.....	167
Valve Tappet Adjustment.....	170
Engine Removal.....	170
Service Chart.....	171
INDEX.....	175

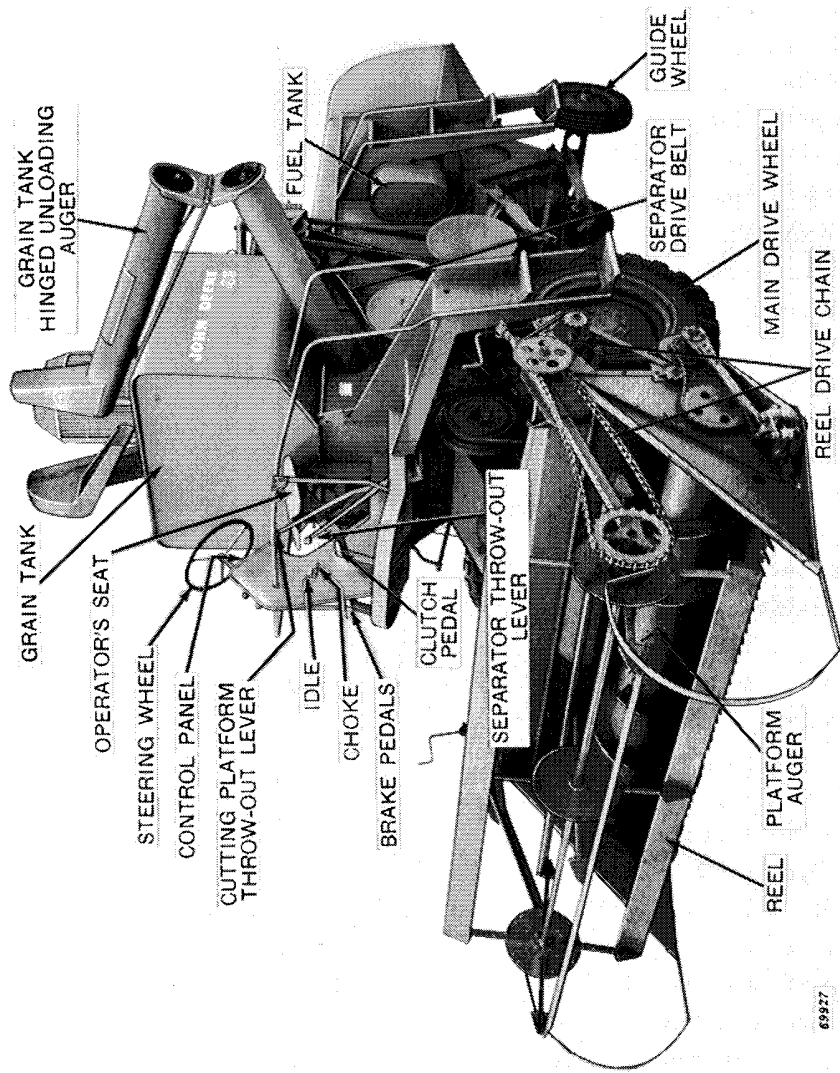

Left-Hand Front View—John Deere 45 Combine—Grain Tank Machine

69327

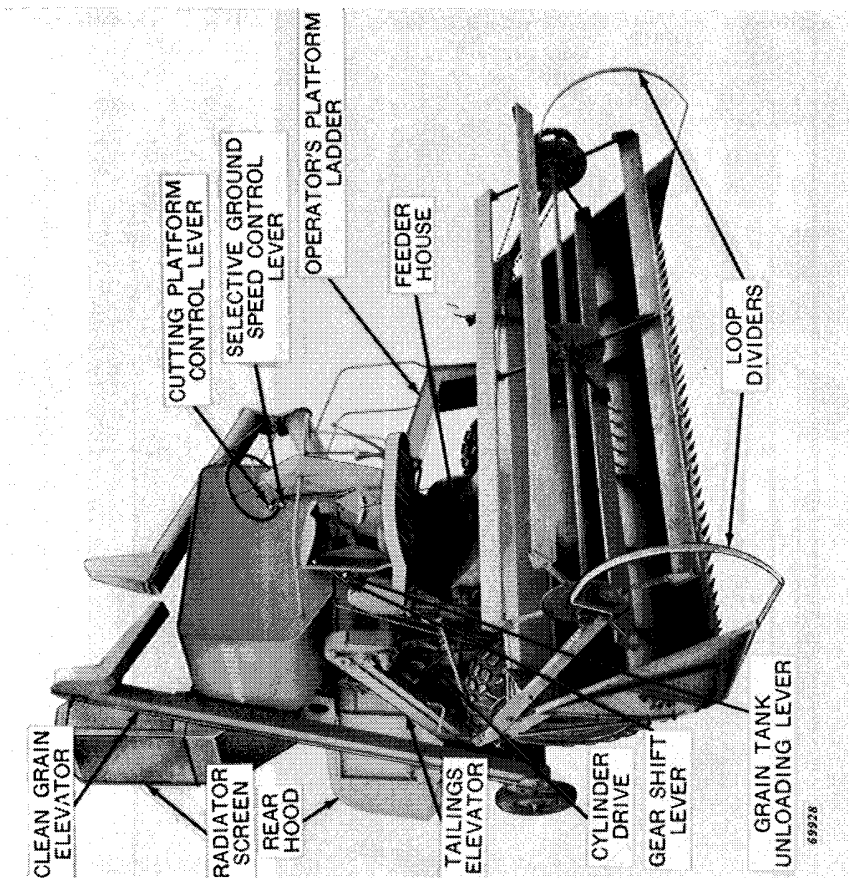

Right-Hand Front View—John Deere 45 Combine—Grain Tank Machine

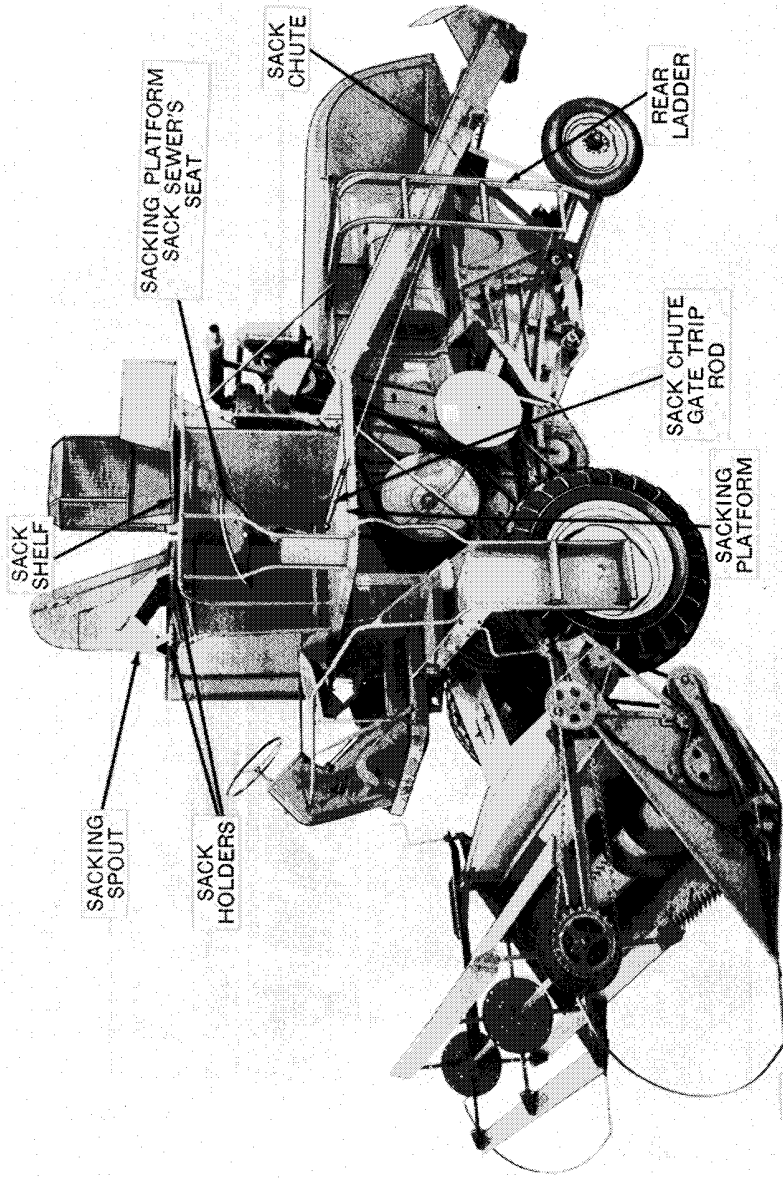

Left-Hand View—John Deere 45 Combine—Equipped with Sacking Attachment

SPECIFICATIONS

COMBINE

Cutter Bar

Width of Cut... 8-Ft. 6-In., 10-Ft. 6-In., or 12-Ft. 6-In.

Length of Cutter Bar..... 8-Ft., 10-Ft., or 12-Ft.

Type of Knife Sections..... Heavy-Duty Overserrated

Reel

Drive..... V-Belt and Chain
No. of Bats..... 3, 4, 6, or 8
Dia. of Reel.... 32-In. or 40-In.

Cutting Platform

Type..... Auger
Hinged or Rigid. Hinged
Range of Cutting Height (Grain) 2-In. Below Wheel Level to 30-3/8-In. Above
Range of Cutting Height (Rice). 3-In. Below Wheel Level to 30-3/8-In. Above

Control..... Hydraulic

Platform Auger

Diameter..... 18-In.
Diameter of Auger Tube..... 10-In.
Type of Auger Fingers..... Round Retracting
Bearings..... Sealed Ball

Cylinder

Type..... Rasp-Bar or Spike-Tooth
Width..... 26 Inches
Diameter..... 22 Inches
Drive..... Roller Chain
Bearings..... Sealed Ball

Concave

Type..... 12-Bar Open-Type Reversible or Spike-Tooth Type

Beater

Type..... Wing
Width..... 26 Inches
Drive..... Belt (Flat)

Separator

Type..... 3 Straw Walker
Width..... 26 Inches
Length..... 10-Ft. 10-In.

Grain Conveyor

Type..... Slat
Drive..... Chain

Fan

Type..... Radial-Flow
Drive..... V-Belt

Chaffer

Type..... Adjustable
Width..... 22-3/4 Inches
Length..... 44 Inches

Sieve

Type..... Adjustable
Width..... 22-3/4 Inches
Length..... 44 Inches

Straw Walkers

Number..... Three
Width..... 7-7/8 Inches
Length..... 105 Inches
Drive..... V-Belt
Bearings..... Oil Soaked Maple
Extension Pans. One on Each Walker

Grain Tank

Capacity..... 40-Bushel
Type of Unloading..... Hinged Auger

Brakes

Type..... Individual, Mechanical Disk-Type

Weights

Grain Combine with 10-Ft. Cutting Platform..... 6100 Lbs. (Approx.)

Rice Combine with 10-Ft. Cutting Platform..... 6400 Lbs. (Approx.)

COMBINE—Continued

Tire Sizes

Main Wheels (Grain)	12-26 (4-Ply) Low Profile
Main Wheels (Rice)	15-26 (6-Ply) Cleat
Main Wheels (Optional)	12-26 (6-Ply) Cleat or Low Profile
Main Wheels (Optional)	13-26 (6-Ply) Cleat or Low Profile
Main Wheels (Optional)	14-26 (6-Ply) Cleat or Low Profile—16" Rims
Main Wheels (Optional)	15-26 (6-Ply) Low Profile—16" Rims
Rear Wheels (Grain and Sacker)	5.50-16 (4-Ply) Rib Implement
Rear Wheels (Rice)	6.00-16 (4-Ply) Skid Ring
Rear Wheels (Optional) (Standard Axle)	6.00-16 (4-Ply) Rib Implement
Rear Wheels (Optional) (Wide Tread Axle)	6.50-16 (4-Ply) Rib Implement
Rear Wheels (Optional)	7.50-16 (4-Ply) Rib Implement
Rear Wheels (Optional) (Wide Tread Axle)	7.50-16 (4-Ply) Rib Implement
Rear Wheels (Optional)	7.50-18 (4-Ply) Skid Ring

SPEED OF VARIOUS UNITS

Auger, Cutting Platform	163 rpm
Beater Behind Cylinder (Fast Idle—No Load)	650 rpm
Cleaning Fan:	
Normal Operating Speed	620 rpm
With Reg. 7-5/16" Dia. Sheave:	
Extreme Low	593 rpm
Extreme High	810 rpm
With Special 10-3/4" Dia. Sheave:	
Extreme Low	398 rpm
Extreme High	489 rpm
With Special 7-3/4" Dia. Sheave:	
Extreme Low	540 rpm
Extreme High	720 rpm
Cylinder (Normal Operating Speed at Fast Idle—No Load)	1075 rpm Regular; 1056 rpm Edible Bean; 894 rpm Rice
Cylinder (Extreme Low) (3/4" Pitch Drive Chain)	394 rpm
Cylinder (Extreme High) (3/4" Pitch Drive Chain)	1075 rpm
Cylinder (Extreme Low) (1" Pitch Drive Chain— with Special 59-Tooth Sprocket)	176 rpm
Cylinder (Extreme High) (1" Pitch Drive Chain)	1056 rpm
Elevator, Tailings	288 rpm
Elevator, Clean Grain	309 rpm
Engine (Fast Idle)	2530 rpm
Feeder House Conveyor	230 rpm
Ground Travel Speeds	(See Page 36)
Knife	435 rpm
Reel	13 to 45 rpm
Shoe Crank	288 rpm
Straw Walker	208 rpm

TRANSMISSION

Type.....	Automotive—3	Speeds Forward
	Speeds Forward, 1	(Grain) (12-26
	Reverse	Tires) mph... 0.68 to 9.05
		Speeds Reverse
		(Grain) (12-26
		Tires) mph... 1.54 to 4.00

NOTE: For LP-Gas specifications, see Operator's Manual furnished with LP-Gas combines.

ENGINE

Make of Engine.	John Deere HA-145	Valve Arrange- ment.....	Valve-in-Head
Bore.....	3-5/8-In.	Valve Clearance	
Stroke.....	3-1/2-In.	Intake.....	.015-In. (When Cold)
Brake Horse- power.....	45	Exhaust.....	.015-In. (When Cold)
Number of Cyl- inders.....	4	Make of Gover- nor.....	John Deere
Piston Displace- ment.....	145 Cu. In.	Make of Carbu- retor.....	Marvel-Schebler
Speed at Full Load.....	2500 rpm	Spark Plug.....	Champion H-10 or Auto-Lite AL-7 or AC-45L Gap .025- In. Heat Range 1200° to 1500° F.
Firing Order....	1-3-4-2	Type of Fuel...	Gasoline (Regular Grade)
Crankcase.....	Cast Integral with Block		
Type of Lubrica- tion.....	Force Feed by Gear Pump to all Connecting Rods, Main Bearings, Camshaft Bear- ings, Governor and Oil Pump Drive. Oil Strainer in Bottom of Pan.		

Capacities (Approx.)		Air Cleaner.....	1 U.S. Quart
Fuel Tank.....	25 U.S. Gallons	Hydraulic Unit	
Cooling System (Radiator)....	6 U.S. Gallons	(Including Hy- draulic Oil	
Engine Crank- case.....	4 U.S. Quarts	Lines and Cyl- inders).....	7 U.S. Quarts
Oil Filter.....	1 U.S. Quart		

(Specifications and design subject to change without notice)

DIMENSIONS—OVER-ALL.

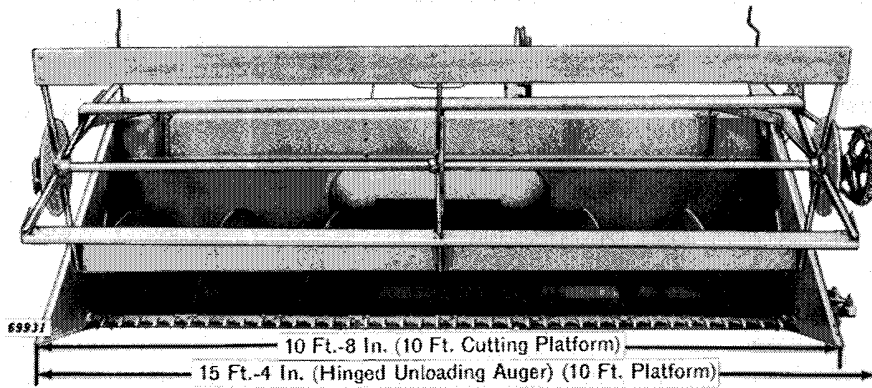
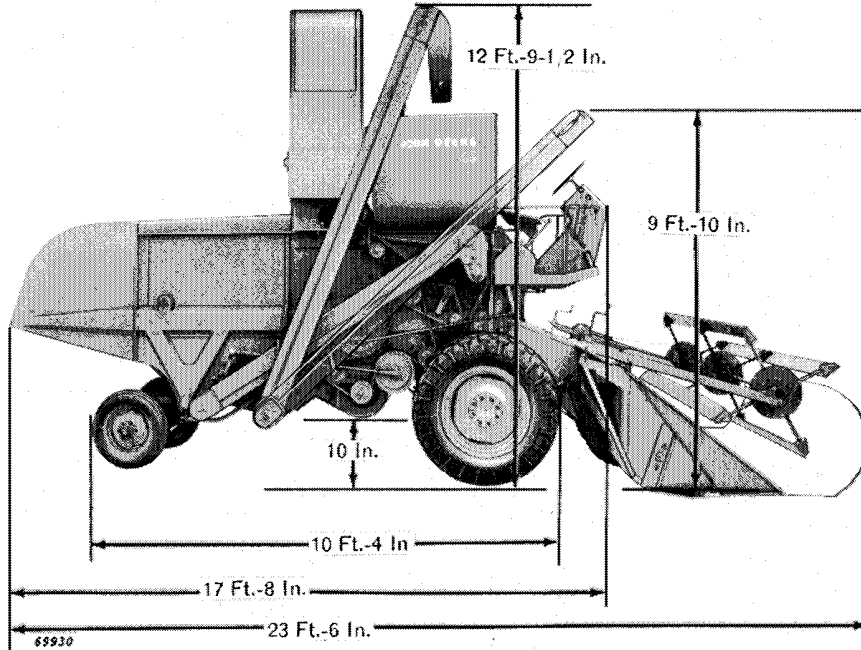

DIMENSIONS—OVER-ALL.

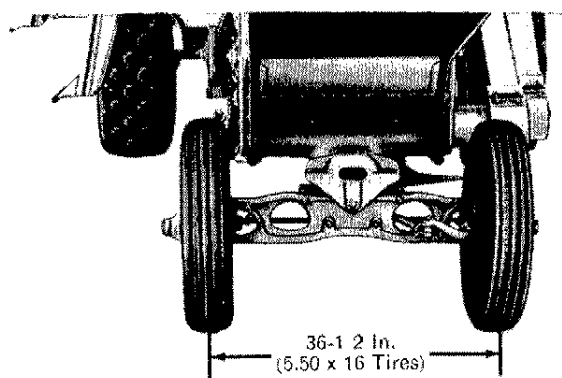
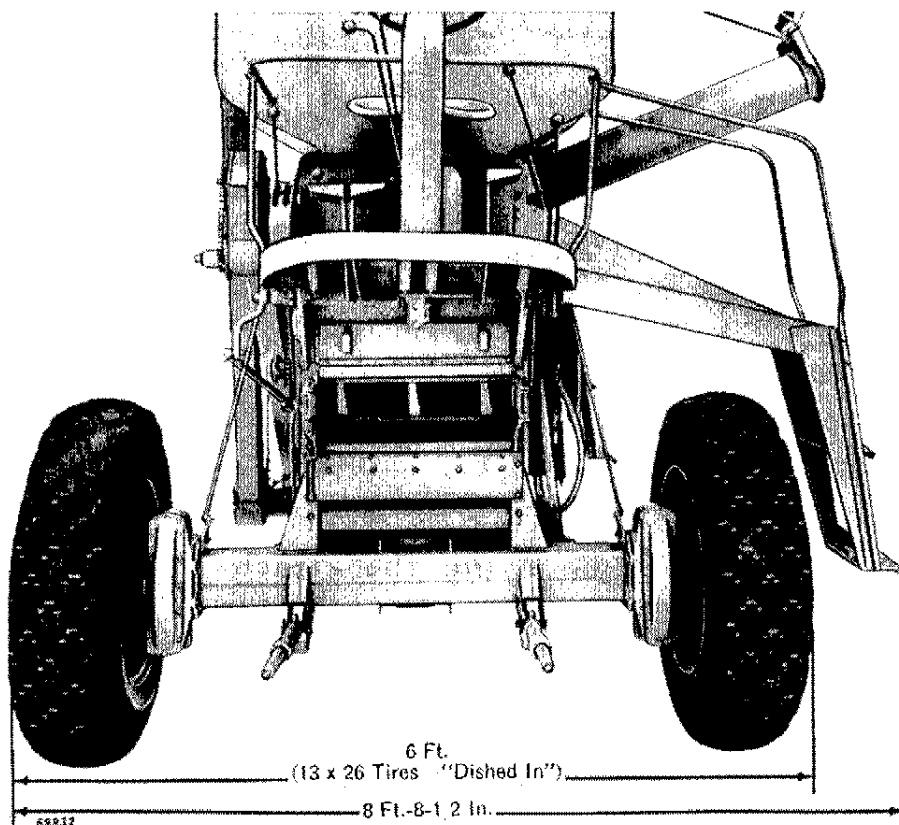

IMPORTANT

Make this manual your guide and adviser and do what it recommends, regardless of what may have been your practice with other makes of combines, or the suggestions that may be made to you by well-meaning friends or neighbors.

When using this combine with special attachments, special servicing of the attachments may be required. This information will be given to you in the instruction book accompanying the attachment.

Parts information for this combine can be obtained from your John Deere dealer.

Always give your John Deere dealer the serial number of combine when ordering parts.

THE COMPLETE OBSERVANCE of one simple rule would prevent many serious injuries each year. THAT RULE IS: "NEVER ATTEMPT TO CLEAN, OIL, OR ADJUST A MACHINE WHILE IT IS IN MOTION."

LUBRICATION

The economical and efficient operation of any machine depends on regular and proper lubrication of all moving parts with a quality lubricant. This is especially true of farm equipment which must operate in hot, dusty conditions over rough ground. Neglected lubrication quickly leads to reduced efficiency, heavy draft, wear, breakdown and replacement of parts.

Use a clean container for storing and handling all lubricants. **See that only clean lubricants go into the working parts of your combine.**

LUBRICATING THE COMBINE.

This combine has been designed with a minimum of lubrication points. There are 22 sealed-for-life bearings and 14 rubber bushings used; these bushings require no lubrication.

There are 6 places to grease every 300 hours of operation.

There are 25 places to grease every 40 hours of operation.

There are **only** 10 places to grease every 8 hours of operation.

There are 3 places to grease every 4 hours of operation.

The locations and intervals of lubricating all grease fittings are shown on pages 16 through 20. All other periodic lubrication and service is described on pages 21 through 27.

CAUTION: Never Attempt to Lubricate Combine or Engine While Engine Is Running.

Wipe dirt from grease fittings and grease gun nozzle before greasing.

Replace all missing or damaged grease fittings immediately.

BEARINGS.

Lubricate at all grease fittings thoroughly, with a good grade of gun grease, until grease oozes out of bearing. This assures that the bearing is full, and also flushes out dirt that may have accumulated in the bearing. However, avoid excessive lubrication. Excessive lubricant that has dropped onto belts should be wiped off immediately to avoid belt slippage.

Two types of sealed bearings are used on this combine. One type is a sealed-for-life bearing which requires no lubrication; the other type is pre-packed at the factory and will require yearly lubrication.

To lubricate bearings where a pipe plug is provided in bearing housing, remove the pipe plug and insert a 1/8-inch diameter slotted grease fitting (JD7805); the slotted fitting allows the bearing housing to be filled to capacity without blowing out seals due to pressure building up. Then remove grease fitting and replace pipe plug.

Fourteen rubber bushings are used on the shoe hangers; these bushings require no lubrication.

LUBRICATION OF LINKAGES.

When lubricating the combine, make a practice of putting a few drops of oil on all clevises, linkages, and other moving parts. This will make them work easier and prolong their life.

LUBRICATION OF CHAINS.

Chains should be lubricated at frequent intervals. A good grade of light oil should be used. A paint brush is a good instrument for applying oil to chains. **CAUTION: Do not oil chains when operating in sandy conditions. Sand will stick to the oiled chain and act as an abrasive.**

KNIFE LUBRICATION.

The amount of lubricant to use on a knife depends on the conditions in which the work is being done. When the grain is being topped and the cutter bar is carried some distance from the ground, liberal lubrication with engine oil is permissible. In many conditions where the cutter bar must operate close to the ground, it is better not to use oil except for a small amount on the knife holders.

TRANSMISSION AND FINAL DRIVE LUBRICATION

Each spring the transmission and final drives should be drained and cleaned out with a safe cleaning solvent.

Weight of Oil (For Transmission, Differential, and Final Drive)		
Unit	Viscosity	Capacity
Transmission-Differential	SAE 90	10 U.S. Pints
Final Drive	SAE 90	4-1/2 U.S. Pints (Each)

ENGINE LUBRICATION

ENGINE BREAK-IN.

The engine on your new combine is shipped from the factory with a special break-in oil in the crankcase. After 150 hours of operation, this oil must be drained from the crankcase and oil filter and replaced with 5 quarts of oil no heavier than SAE 10W or SAE 5W-20.

Drain and replace oil every 150 hours of operation thereafter. Use 10W or SAE 5W-20 weight oil for the first 600 hours of operation; then use the correct oil as specified on page 15. For further break-in instructions on the engine, see page 33.

TYPES OF CRANKCASE OIL.

The engine of your combine with its force-feed pressure lubricating system has one of the finest oiling systems it is possible to produce. Do not handicap it by trying to save money with inferior oil. It pays to buy only nationally-known brands of oil.

It is impossible to determine from the appearance of an oil whether it is best suited to your engine and service conditions. The petroleum industry markets several types of crankcase oils. These types have been defined by the American Petroleum Institute as follows:

ENGINE LUBRICATION—Continued

Service ML—Oil suitable for service typical of gasoline and other spark ignition engines operating under light loads and favorable service conditions.

Service MM—Oil suitable for service typical of gasoline and other spark ignition engines operating under moderate to severe service conditions.

Service MS—Oil suitable for service typical of gasoline and other spark ignition engines operating under unfavorable or severe types of service conditions.

For average service conditions, oil specified "For Service MM" is recommended for use in your combine engine.

For exceptionally severe service, combinations of heavy loads and high temperatures, or low temperature start and stop service, it may be possible to extend engine life by use of oils specified "For Service MS."

In some cases, where owners have had successful experience with certain brands of oils now specified "For Service ML," it will be possible to continue use of these oils but, due to the wide variations likely to be encountered between various brands, their use cannot be generally recommended.

Weight of Oil.

Your John Deere Combine engine was made with the same precision as a fine automobile engine, with clearances between bearing surfaces as fine as a ten-thousandth part of an inch. If oil is expected to lubricate these surfaces, it first must get there. Therefore, weight or viscosity of the oil is very important.

Oil of the wrong weight can result in loss of power, excessive fuel consumption, and undue wear on moving parts.

In a new engine it is important to use the oil specified in the temperature-oil weight chart below. **IMPORTANT: Follow the engine break-in instructions given on page 14.**

Air Temperature	Engine Crankcase, Air Cleaner, and Hydraulic Systems
Above 32°F.	SAE 20 or SAE 10W-30
Below 32°F.	SAE 10W or SAE 5W-20



Suggest:

If the above button click is invalid.





Please download this document

first, and then click the above link

to download the complete manual.

Thank you so much for reading

RIGHT-HAND SIDE OF SEPARATOR

SYMBOLS	
	Grease Every 8 Hours of Operation with a Good Grade of Gun Grease.
	Grease Every 40 Hours of Operation with a Good Grade of Gun Grease.
	Grease Every 300 Hours of Operation with a High Melting Ball or Roller Bearing Grease of Medium Consistency.
	Hand Pack Every 300 Hours of Operation with a High Melting Ball or Roller Bearing Grease of Medium Consistency.
	Scaled-for-Life-Bearing -- No Lubrication Required.

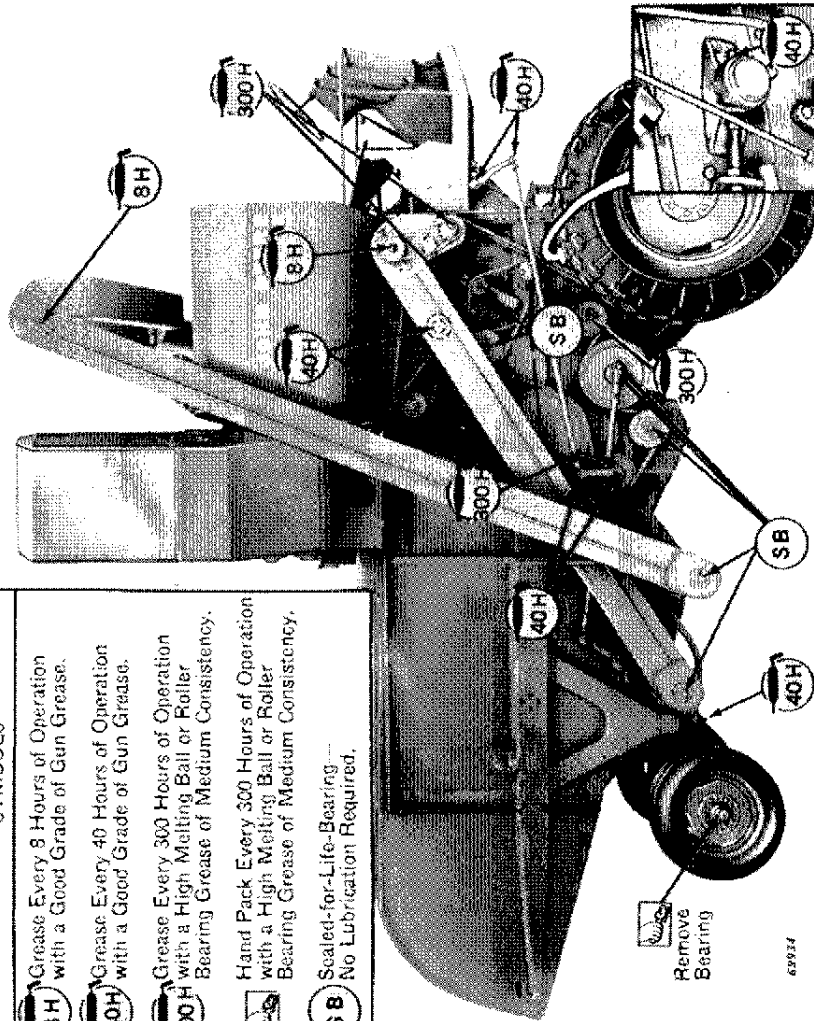

62934

<https://www.ebooklibonline.com>

Hello dear friend!

Thank you very much for reading.

Enter the link into your browser.

The full manual is available for immediate download.

<https://www.ebooklibonline.com>