

John Deere 45 Hi Lo Combines



JOHN DEERE

OPERATORS MANUAL

John Deere 45 Hi Lo
Combines

OMH90736 K2 English

John Deere Harvester Works
OMH90736 K2

LITHO IN U.S.A. (REVISED)
ENGLISH

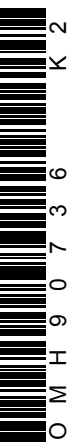

TO THE PURCHASER

The self-propelled combine you have just purchased was designed and manufactured to the traditionally high quality standards of all John Deere Farm Equipment. Your combine has been thoroughly inspected and tested, not only at the factory, but at your dealer's by a trained John Deere Serviceman. We are confident that you will receive years of dependable, economical service from your John Deere Self-Propelled Combine.

If you should find that you require information not covered in this manual, consult your John Deere dealer. He will be glad to answer any questions that may arise regarding the operation and service of the combine. He has trained mechanics who are kept informed on the best methods of John Deere Combine servicing, and can give you prompt know-how service in the field or in his shop.

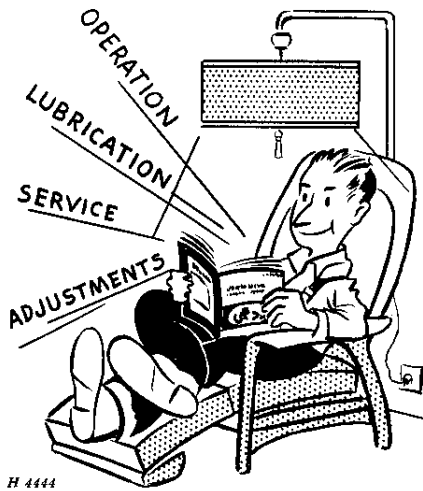

Study This Manual Carefully, Keep It Handy, In A Safe Place, For Future Reference.

LOCATION REFERENCE

"Right-hand" and "left-hand" sides are determined by facing in the direction the combine will travel when in use.

"Clockwise" refers to parts turning to the right like the hands of a clock. "Counter-clockwise" refers to parts turning to the left.

ENGINE REFERENCE ONLY

Timing gear end of the engine is referred to as the "front"; flywheel end as the "rear."

KEEP YOUR COMBINE A JOHN DEERE COMBINE

Genuine John Deere Parts fit properly and insure satisfactory service because they are made from the original patterns and from the same materials as used in new machines. Should your combine require replacement parts, go to your John Deere dealer where you can obtain Genuine John Deere Parts—accept no substitutes.

SERIAL NUMBERS

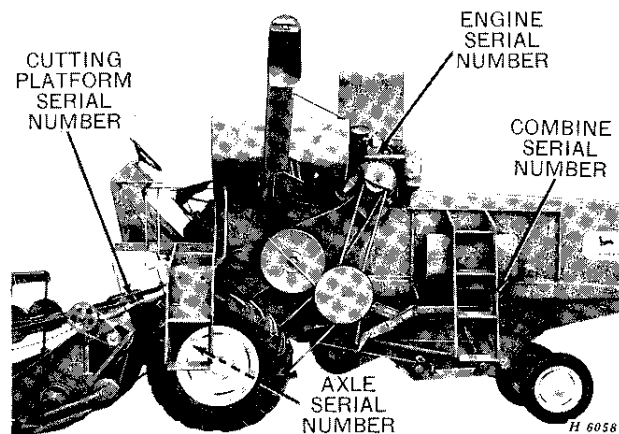

Your combine, cutting platform, and engine have serial numbers.

When ordering parts, always bring with you the model and serial numbers as given on the serial number plates. By doing so, you will assist your John Deere dealer in giving you prompt, efficient service.

Record the serial numbers and date purchased in the spaces provided on this page.

The combine serial number is on a plate located on the support bracket at the rear end of the fuel tank.

The axle serial number is on the top, left-hand end of the axle tube.

The engine serial number is on a plate located on top of the flywheel housing.

The cutting platform serial number is on a plate located on the outside of the right-hand platform divider.

Combine Serial No. _____

Engine Serial No. _____

Axle Serial No. _____

Cutting Platform Serial No. _____

Date Purchased _____

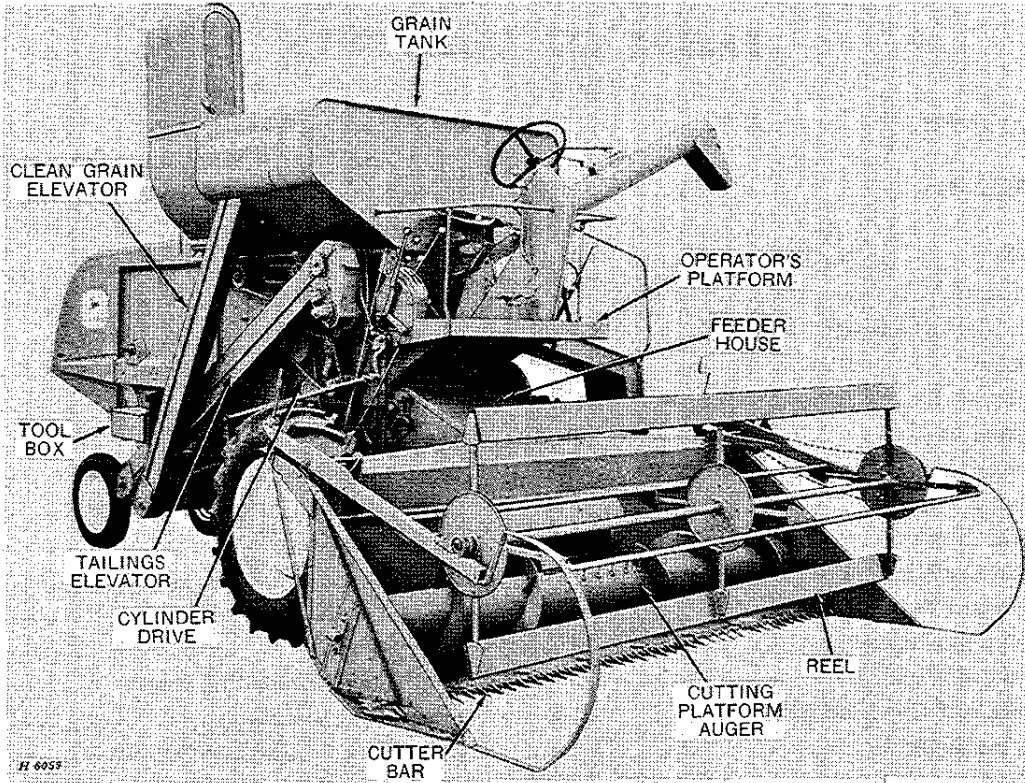

Right-Hand Front View—John Deere 45 Grain Tank Combine

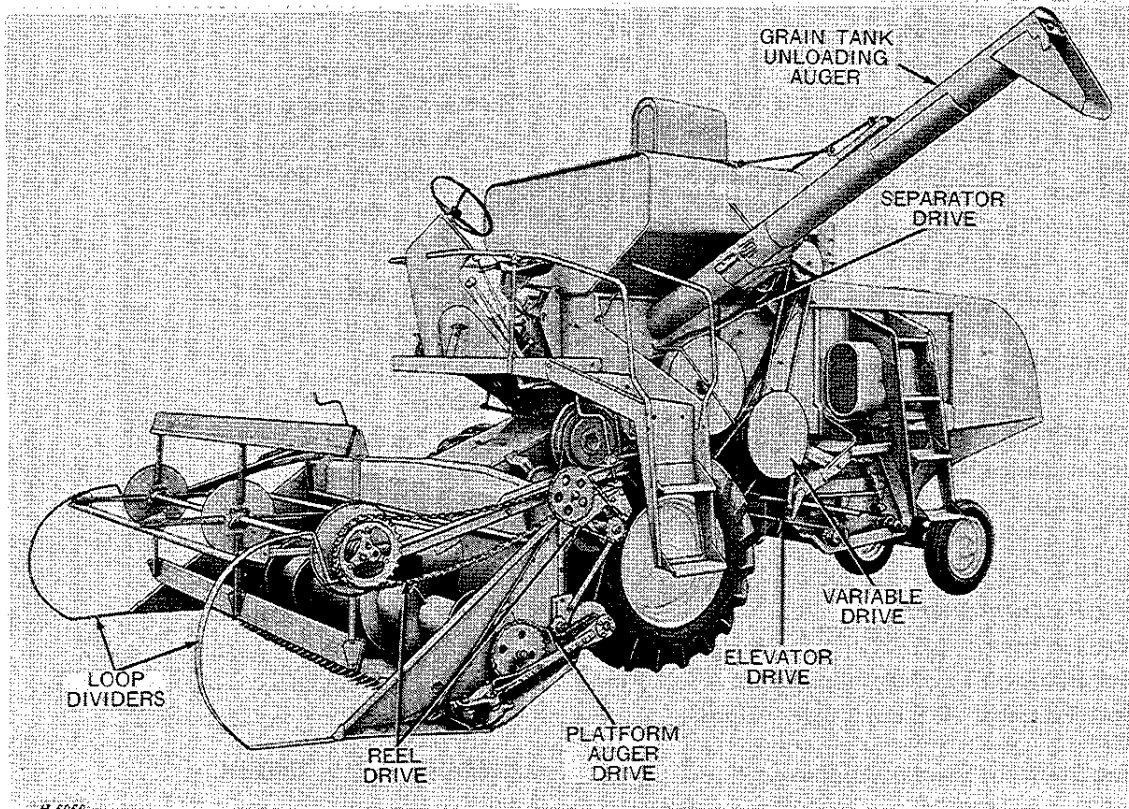

Left-Hand Front View—John Deere 45 Grain Tank Combine

<https://www.ebooklibonline.com>

Hello dear friend!

Thank you very much for reading.

Enter the link into your browser.

The full manual is available for immediate download.

<https://www.ebooklibonline.com>

TABLE OF CONTENTS

	<i>Page</i>		<i>Page</i>
GENERAL VIEWS	1	Belt Pickup.....	47
SPECIFICATIONS	3-7	Attaching Cutting Platform to Separator..	48
OPERATION	8-23	Cylinder and Concave Grate.....	49
Combine Controls.....	8	Feed Rolls Attachment.....	56
Operator's Platform Hinged Ladder.....	10	Beater Behind the Cylinder.....	56
Operator's Seat.....	10	Grain Conveyor.....	57
Combine Break-In.....	11	Cleaning Fan.....	58
Engine Break-In.....	11	Chaffer.....	61
Before Operation Checks and Adjustments	11	Sieve.....	62
Starting the Engine.....	11	Shoe Pitman.....	63
Stopping the Engine.....	12	Clean Grain and Tailings Elevators.....	64
Starting the Combine.....	12	Straw Walkers.....	66
Selecting Proper Ground Speed.....	12	Straw Spreader.....	67
Speed of Various Units.....	12	Straw Chopper.....	67
Cross-Sectional View.....	13	Grain Tank Extension.....	68
Fundamentals of Combine Harvesting.....	14	ScourKleen.....	68
Operating Suggestions.....	14	Grain Tank Unloading Auger.....	69
Transporting.....	16	Separator Drive.....	70
Highway Safety Lighting.....	17	Selective Ground Speed Control.....	71
Cold Weather Operation.....	17	Clutch.....	73
Cab for Operator's Platform.....	18	Brakes.....	73
Weather Brake.....	18	Transmission.....	74
Two-Row Corn Attachment.....	18	Hydraulic System.....	74
Suggested Settings for Combining Vari- ous Crops.....	19	Steering Mechanism.....	75
Beginning of the Season Service.....	21	Toe-In Adjustment.....	76
End of the Season Service.....	22	Care of Rubber Tires.....	76
Safety Suggestions.....	23	Care of Chains and V-Belts.....	78
LUBRICATION	24-33	Service Chart.....	80
ADJUSTMENTS AND SERVICE	34-88	ENGINE SERVICE	89-102
Inspection Doors and Ports.....	34	Fuel System.....	89
Slip Clutches.....	34	Carburetor.....	90
Reel.....	35	Governor.....	90
Cutter Bar.....	39	Wiring Diagram.....	92
Cutting Platform Auger.....	42	Ignition System.....	93
Feeder Conveyor.....	44	Ignition Timing.....	94
Cutting Platform Leveling Adjustment... ..	45	Starting System.....	95
Cutting Platform Height Range Adjust- ment.....	46	Cooling System.....	98
Cutting Platform Special Equipment.....	46	Valve Tappet Adjustment.....	99
		Engine Removal.....	100
		Special Equipment.....	100
		Service Chart.....	101
		ALPHABETICAL INDEX	103

SPECIFICATIONS

COMBINE

3

Cutter Bar
 Length of Cutter Bar..... 8 Ft. or 10 Ft., or 12 Ft.
 Width of Cut..... 8 Ft. 6 In. or 10 Ft. 6 In. or 12 Ft. 6 In.
 Type of Knife Sections . Heavy-Duty Over-Serrated

Reel
 Drive..... Chain and V-Belt
 No. of Slats. 4 Regular; 3, 6, or 8 Special
 Dia. of Reel. 32 In. or 40 In.
 Speed Range. 13 rpm to 45 rpm

Cutting Platform
 Type of Feed.... Auger
 Range of Cutting Height (Grain)... 2 In. Below Wheel Level to 31-3/8 In. Above
 Range of Cutting Height (Rice)... 3 In. Below Wheel Level to 30-3/8 In. Above
 Height Control..... Hydraulic (2 Cylinders)

Cutting Platform Auger
 Diameter.. 18 In.
 Dia. of Auger Tube. 10 In.
 Type of Auger Fingers..... Round Retracting

Cylinder
 Type..... Rasp-Bar or Spike-Tooth
 Width..... 26 In.
 Diameter.. 22 In.
 Number of Bars..... 8 Rasp-Bars or 10 Spike-Tooth Bars (5 Bars with 12 Teeth and 5 Bars with 13 Teeth)

Drive..... Roller Chain
 Speed Range 394 rpm to 1075 rpm (3/4-Inch Pitch Cylinder Drive Chain)
 176 rpm to 1056 rpm (1-Inch Pitch Cylinder Drive Chain—Ed. Bean)

Concave
 Type..... 12-Bar Open Type or Spike-Tooth Type
 Width..... 26 In.

Beater (Behind the Cylinder)
 Type..... Wing
 Width..... 26 In.
 Diameter.. 12 In.
 Speed..... 650 rpm

Separator
 Type..... Grain Conveyor, Straw Walker
 Width..... 26 In.
 Length of Separating Surface..... 130 In. (Straw Walker Pans Extended)
 Area of Separating Surface.. 3,380 Sq. In.

Grain Conveyor
 Type..... Slat
 Drive..... Chain

Cleaning Fan
 Type..... Radial Flow
 Drive..... V-Belt
 Speed Range. 593 rpm to 810 rpm

Chaffer
 Type..... Adjustable
 Width..... 22-3/4 In.
 Length with Tailings Finger Bar 54-3/4 In.
 Area..... 1,246 Sq. In.

Sieve
 Type..... Adjustable
 Width..... 22-3/4 In.
 Length..... 43-7/8 In.
 Area..... 1,000 Sq. In.
 Total Cleaning Area. 2,246 Sq. In.

Straw Walkers
 Number... Three
 Width..... 7-7/8 In.
 Length with Pans Extended... 113 In.
 Area..... 2,938 Sq. In.
 Number of Steps.... Five
 Drive..... V-Belt
 Bearings... Oil-Soaked Maple
 Extension Pans.... One on Each Walker

Grain Tank
 Capacity... 40-Bushel, Approx. (Type and Condition of Crop Will Determine Actual Volume)
 Capacity with Grain Tank Extensions (Special Equipment)... 48-Bushel
 Type of Unloading.. Hinged Auger

Brakes
 Type..... Individual, Mechanical Disk-Type

Transmission
 Automotive—3 Speeds Forward, 1 Reverse

Weights
 Grain Combine with 10-Ft. Cutting Platform. 6,600 Lbs. (Approx.)
 Rice Combine with 10-Ft. Cutting Platform. 6,900 Lbs. (Approx.)

Dimensions. See pages 6 and 7

TIRE SIZES

Main Wheels

Grain.....	13.6-26 (12-26) (4-Ply) Low Profile
Rice.....	18.4-26 (15-26) (6-Ply) Rice
Optional..	13.6-26 (12-26) (6-Ply) Cleat
Optional..	14.9-26 (13-26) (6-Ply) Cleat or Low Profile
Optional..	16.9-26 (14-26) (6-Ply) Cleat or Low Profile
Optional..	18.4-26 (15-26) (6-Ply) Cleat or Low Profile—16" Rims

Guide Wheels

Grain and Sacker	5.50-16 (4-Ply) Rib Implement
Rice.....	6.00-16 (4-Ply) Skid Ring
Optional.....	6.50-16 (4-Ply) Rib Implement
Optional.....	7.50-16 (4-Ply) Rib Implement
Optional.....	7.50-18 (4-Ply) Skid Ring

WHEEL TREAD

Tire Sizes	Center-to-Center Wheel Tread
13.6-26 (12-26) (Dished In).....	72 Inches
13.6-26 (12-26) (Dished Out).....	84 Inches
14.9-26 (13-26).....	73-1/2 Inches
18.4-26 (15-26).....	76-1/2 Inches
5.50-16.....	36 Inches (Standard Axle)
6.00-16.....	43 Inches (Rice Axle)
7.50-18.....	60 Inches (Wide Tread Axle)
7.50-18.....	74 Inches (Wide Tread Axle)

NOTE: Rear Tires can be Interchanged on the Various Rear Axles.

SELECTIVE GROUND SPEED CONTROL RANGE

13.6-26 (12-26) Tires—Grain Drive (Min.) (Max.)		18.4-26 (15-26) Tires—Rice Drive (Min.) (Max.)	
1st Gear.....	.69 to 1.78 mph	1st Gear.....	.65 to 1.69 mph
2nd Gear.....	1.50 to 3.88 mph	2nd Gear.....	1.42 to 3.69 mph
3rd Gear.....	3.54 to 9.16 mph	3rd Gear.....	3.36 to 8.71 mph
Reverse.....	1.56 to 4.04 mph	Reverse.....	1.48 to 3.84 mph
14.9-26 (13-26) Tires—Optional (Min.) (Max.)		16.9-26 (14-26) Tires—Optional (Min.) (Max.)	
1st Gear.....	.71 to 1.85 mph	1st Gear.....	.61 to 1.59 mph
2nd Gear.....	1.55 to 4.02 mph	2nd Gear.....	1.33 to 3.46 mph
3rd Gear.....	3.66 to 9.48 mph	3rd Gear.....	3.15 to 8.16 mph
Reverse.....	1.62 to 4.18 mph	Reverse.....	1.39 to 3.60 mph

CAPACITIES (Approx.)

Fuel Tank.....	25 U. S. Gallons	Final Drive (2).....	4-1/2 U. S. Pints (In Each)
Cooling System (Radiator).....	6 U. S. Gallons	Air Cleaner.....	1 U. S. Quart
Engine Crankcase (Including Oil Filter).....	7 U. S. Quarts	Hydraulic Unit (Including Hydraulic Oil Lines and Cylinders)	7 U. S. Quarts
Transmission.....	10 U. S. Pints		

ENGINE

NOTE: For LP-Gas or Diesel Engine Specifications, see Operator's Manual furnished with LP-Gas or Diesel Combine.

Make of Engine	John Deere—HC-145G	Valve Arrangement . .	Valve-in-Head
Bore	3-5/8 In.	Valve Clearance In-	
Stroke	3-1/2 In.	take012-In. (When Cold)
Brake Horsepower* . . .	53	Exhaust018-In. (When Cold)
Number of Cylinders . .	4	Make of Governor . . .	Pierce
Piston Displacement . .	145 Cu. In.	Make of Carburetor . .	Marvel-Schebler
Max. Load Speed	2500 rpm	Spark Plug	Champion H-10 or Auto-Lite AL-7 or AC-45L Gap .025- In. Heat Range 1200° to 1500° F.
Firing Order	1-3-4-2	Electrical System	12-Volt
Crankcase	Cast Integral with Block	Cooling System	Water Pressure Type
Type of Lubrication . .	Force Feed by Gear Pump to All Connecting Rods, Main Bearings, Governor, and Oil Pump Drive. Oil Strainer in Bottom of Pan	Type of Fuel	Gasoline (Regular Grade)

*Calculated at 60° F. and 29.92 inches Hg. at Sea Level

SPECIAL EQUIPMENT AVAILABLE

	<i>Page</i>		<i>Page</i>
Adjustable Long Divider	46	Guard and Knife Repair Block	41
Air Precleaner	100	Highway Safety Lighting Attachment	17
Axle Extensions, Front	77	Hydraulic Cylinder Support Chains	47
Belt Pickup Attachment	47	Hydraulic Reel Lift	38
Cab for Operator's Platform	18	Lifting Guards	41
Chaffers (Special Types)	62	Lighting Attachment	17
Chain Detacher	78	Perforated Elevator Connections and Clean-	
Chromed Guards and Sections	41	Out Doors	65
Cleaning Fan Housing Protective Shield	60	Reel End Shields	37
Concave Cover Plates	55	ScourKleen	68
Corn Attachment	18	Shields for Separator Drives	72
Cutter Bar Extension	41	Side Hill Attachment	63
Cutter Bar Guard Straightener	41	Sieves (Special Types)	62
Cutting Platform Auger Flight Extensions	43	Spike-Tooth Straightener	54
Cutting Platform Auger Grain Deflectors	43	Spike-Tooth Wrench	54
Cutting Platform Protection Plates	46	Spinning Fan Screens	60
Cutting Platform Support Stand	47	Steel Elevator Paddles	64
Cylinder Shear Hub	52	Stone Trap	56
Engine Cover	100	Straw Chopper	67
Feeder Conveyor Front Shield Extension	46	Straw Spreader	67
Feed Rolls Attachment	56	Variable Reel Drive	38
Grain Tank Extension	68	Weather Brake	18
		Weed Bar	38
		Wide Tread Rear Axles—60" and 74"	77

(Specifications and design subject to change without notice)

COMBINE DIMENSIONS—OVER-ALL

NOTE: Combine equipped with 13.6-26 (12-26) main wheel tires and 5.50-16 guide wheel tires for dimensions

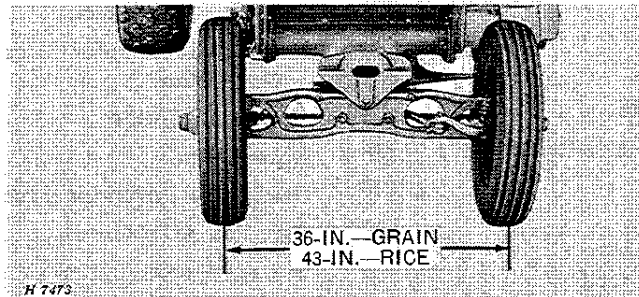
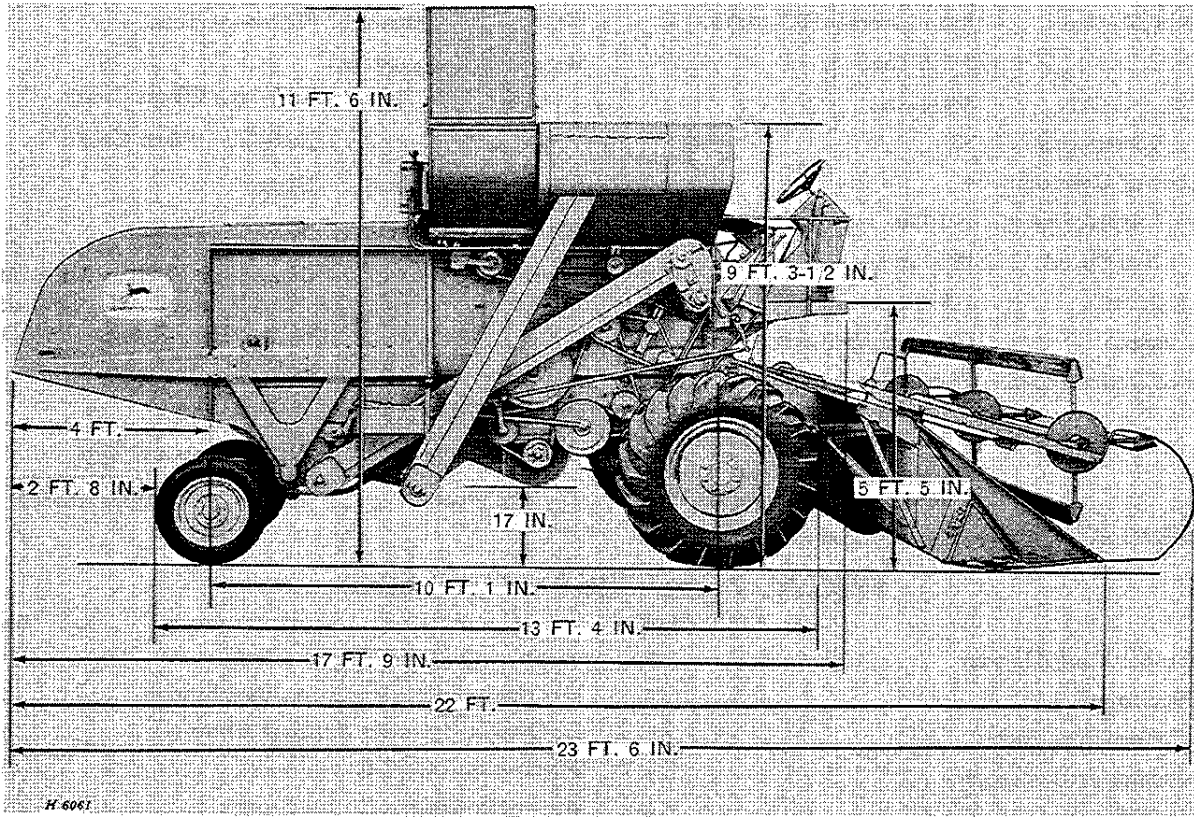
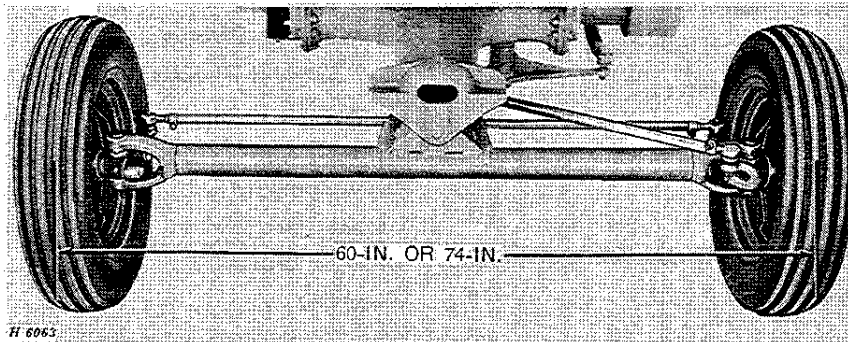
**Standard Rear Axle****Wide-Tread Rear Axle**

COMBINE DIMENSIONS—OVER-ALL—Continued

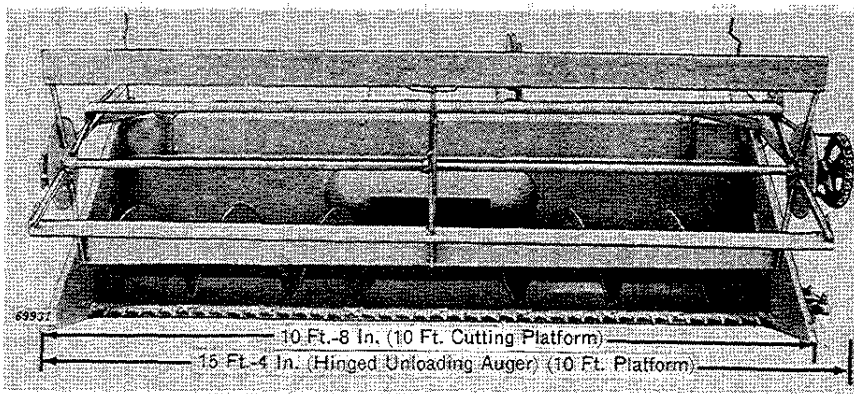
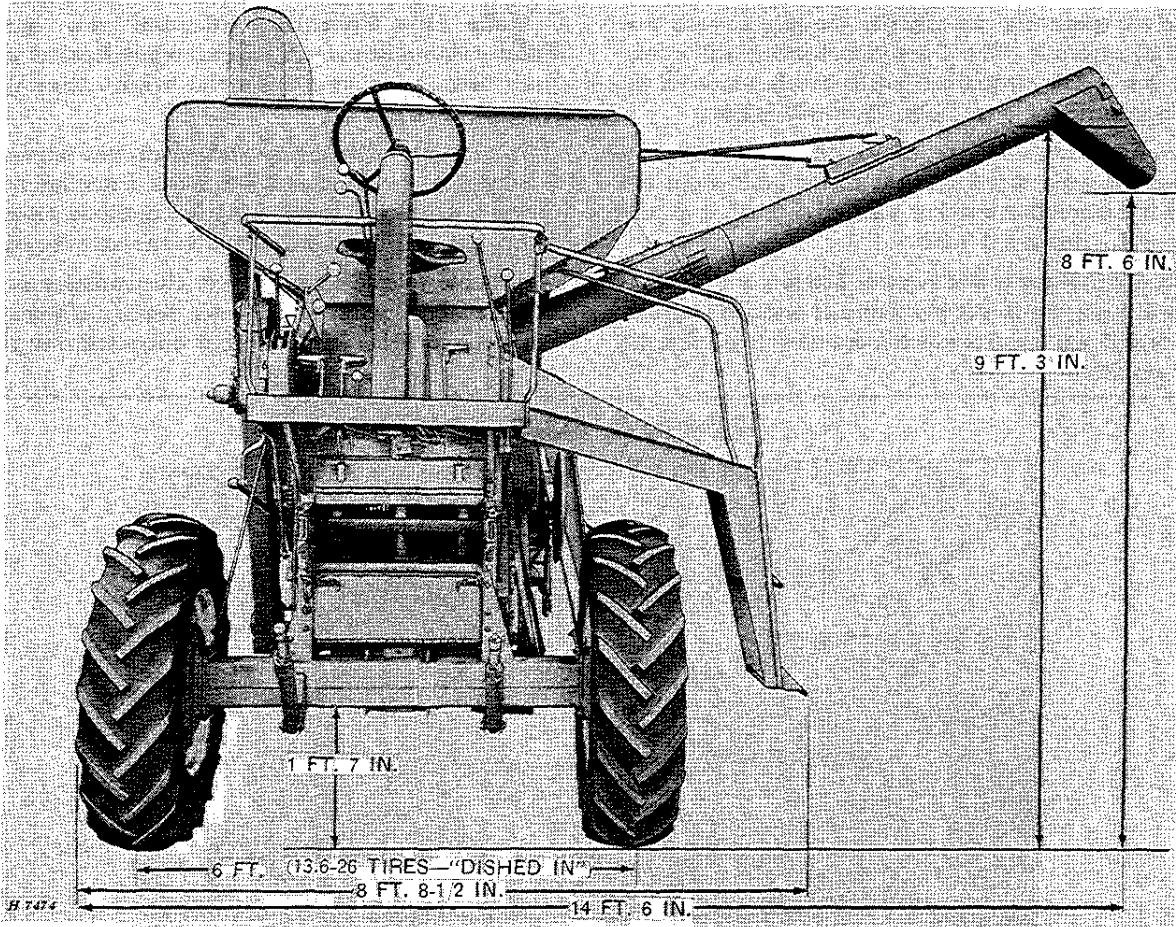

OPERATION

Before operating the combine, be sure to read this manual carefully. The Operation section will make you thoroughly acquainted with the function of all working units of your John Deere Combine.

A cross-sectional view is provided on page 13, showing exactly what happens to the grain from the time it enters the cutting platform until it is delivered to the grain tank.

The Adjustments and Service section of this manual will help you to become familiar with the adjustments and service procedures necessary to obtain the best results.

Make this Operator's Manual your guide. Follow its recommendations, regardless of what may have been your practice with other combines.

Special attachments are described and illustrated throughout the manual. When an attachment requires operating and servicing instructions, these instructions will be furnished with the attachment.

Genuine John Deere parts for this combine can be obtained from your John Deere dealer. Always give him your combine serial number when ordering parts.

COMBINE CONTROLS

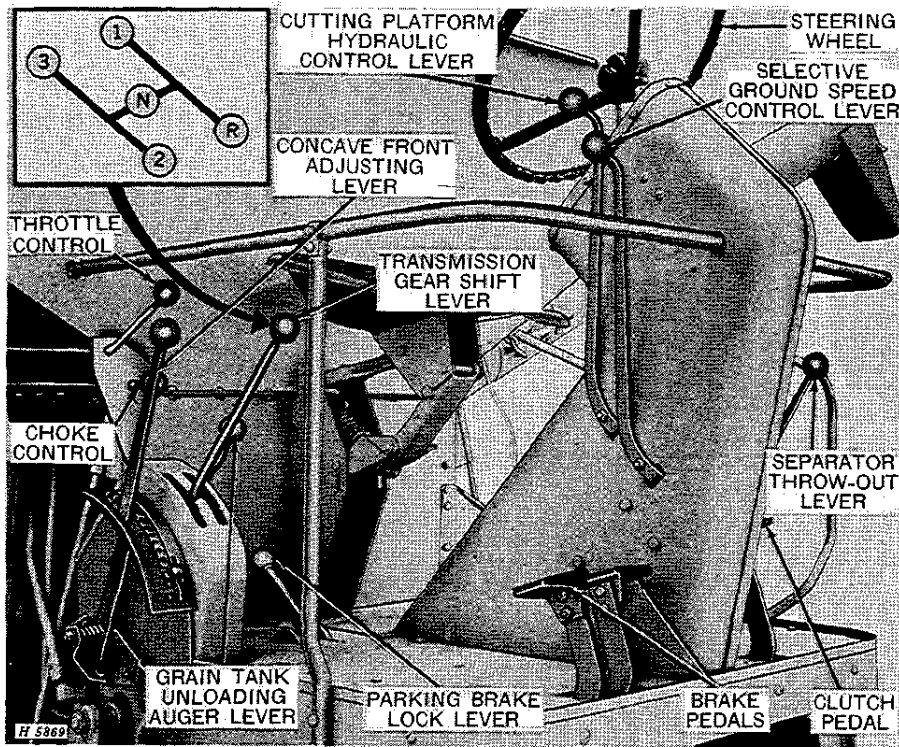

The combine controls are located on the operator's platform within easy reach of the operator. Those controls whose purpose and function are obvious will not be explained.

TRANSMISSION GEARSHIFT LEVER

There are three speed ranges forward and one reverse range. Positions of gearshift lever for different transmission speed ranges are shown by diagram.

CAUTION: Be certain the gearshift lever is in neutral position before starting engine.

GRAIN TANK UNLOADING LEVER

This lever engages auger when moved forward. To disengage, move lever to rearward. Grain tank unloading drive and separator drive are independent. If engine is running, separator can be stopped without affecting unloading of grain tank.

SEPARATOR THROW-OUT LEVER

This lever is disengaged when in forward position. To engage, pull lever rearward.

SELECTIVE GROUND SPEED CONTROL LEVER

To increase ground travel speed within a selected transmission range, move lever forward. It will automatically return to neutral position when released and speed will remain as selected. Ground travel speeds from .69 to 9.16 mph (13.6-26 tires) are available at governed engine speed. Separator speed remains constant.

CUTTING PLATFORM HEIGHT CONTROL LEVER

This lever controls the height of the platform through a hydraulic mechanism. Platform height range is from 2 inches below wheel level to 31-3/8 inches above wheel level on grain combines, and from 3 inches below wheel level to 30-3/8 inches above wheel level on rice combines. Move lever forward to lower platform; pull lever rearward to raise platform. When released, lever automatically returns to neutral position and cutting platform remains at selected position. As a safety measure, cutting platform height cannot be changed unless engine is running.

PARKING BRAKE LOCK LEVER

The parking brake lock lever is used to lock the wheel brakes so the combine cannot move if left unattended. To engage, step on brakes, and move lever forward. To disengage, pull lever rearward.

Never attempt to move combine with parking brake lock lever engaged.

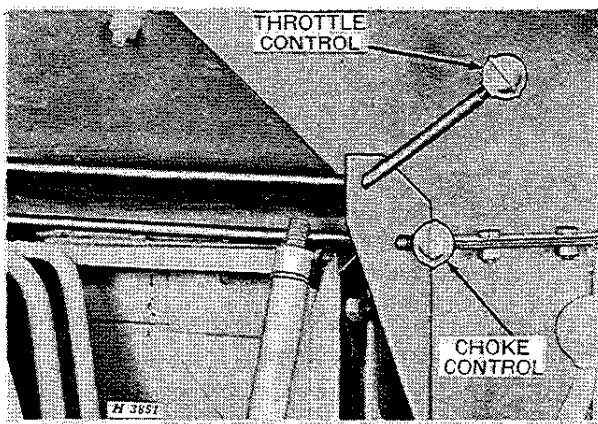

THROTTLE CONTROL

Move throttle one-quarter forward to start engine. Move all the way forward for normal operation (fast idle); move lever rearward for slow idle.

CHOKE CONTROL

Pull choke all the way forward to start engine. After engine runs a few revolutions, move choke all the way rearward.

CUTTING PLATFORM THROW-OUT LEVER

Cutting platform is disengaged when lever is in forward position. To engage, pull lever rearward.

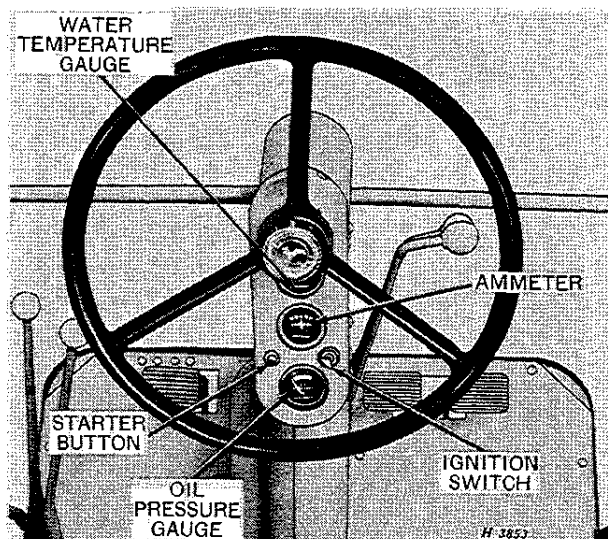

CONCAVE FRONT ADJUSTING LEVER

Move lever forward to lower front of concave. Move lever rearward to raise front of concave.

WATER TEMPERATURE GAUGE

This gauge indicates the water temperature in the cooling system—not the quantity. Normal operating temperature is 160° to 200° F. (indicated by green band on dial). If 200° F. or above (indicated by red band on dial), stop engine and determine cause.

AMMETER

This gauge indicates the rate of charge or discharge of the batteries. If ammeter shows discharge for an extended period during normal operation, check for a ground, short circuit, or faulty regulator. If ammeter shows high charge continually, inspect for low batteries, faulty connections, low battery water, or bad regulator.

OIL PRESSURE GAUGE

This gauge indicates the pressure of engine lubricating oil. Oil pressure will vary slightly but with recommended oil it should read **NORMAL** at full governed speed. If oil pressure drops, **stop immediately and determine cause.**

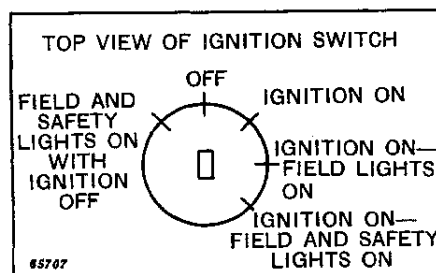

OPERATOR'S SEAT

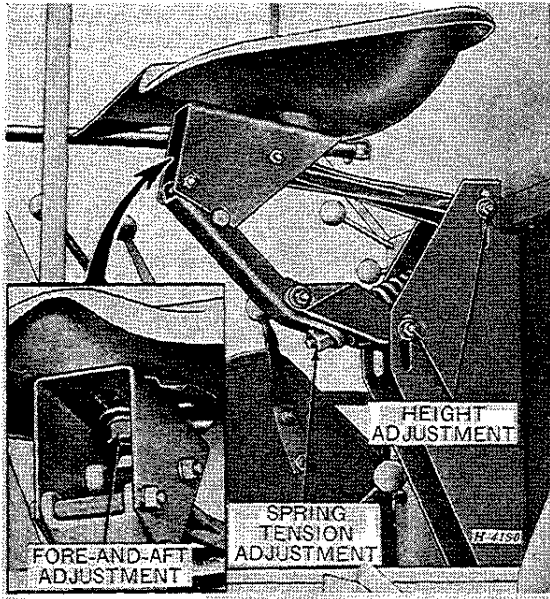

Operator's Seat—Down Position

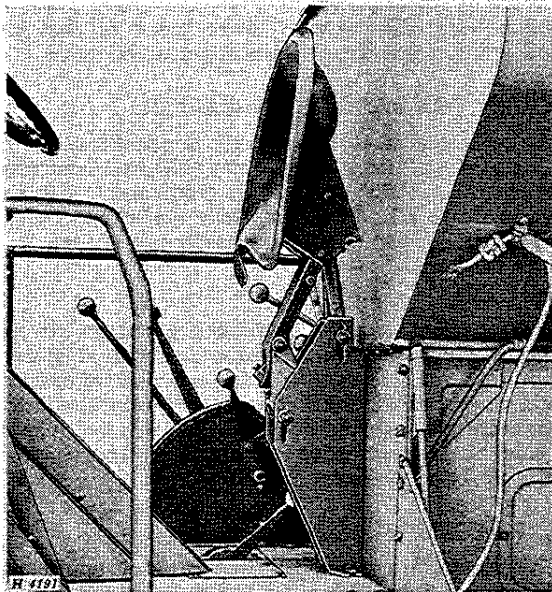

Operator's Seat—Up Position

The operator's seat may be moved up and down, forward and rearward and also may be folded back into a vertical position against the grain tank should the operator desire to work in a standing position. Spring tension on the seat may be increased or decreased to suit the requirements of the individual operator.

Seat height adjustment—loosen the two nuts in the seat mounting bracket, move seat up or down as desired and secure nuts.

Fore-and-aft adjustment—loosen nut under seat, shown in insert, and move seat forward or rearward as desired and tighten nut.

Spring tension adjustment—increase or decrease tension of spring by threading adjusting nut in or out.

Folded position of seat—lift seat up and back at same time—to lower seat push out and down.

OPERATOR'S PLATFORM HINGED LADDER (Optional Equipment)

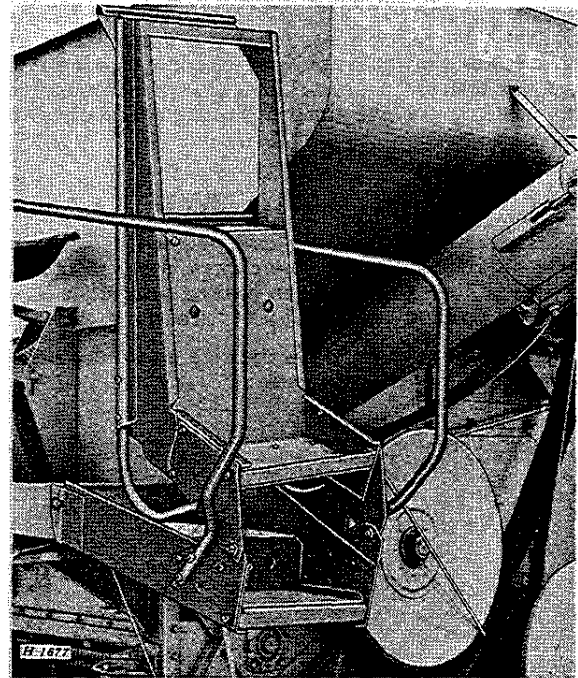

Hinged Ladder in Retracted Position

The operator's platform hinged ladder must be used with the corn attachment.

IMPORTANT: When lowering the hinged ladder, always use the rope provided so the ladder may be lowered slowly. Do not allow the ladder to drop, as damage may result.

CAUTION: When lowering the hinged ladder, always be certain that no one is standing where he might be struck by the ladder.

COMBINE AND ENGINE BREAK-IN

COMBINE

Check all V-belt drives carefully for proper alignment and tension. Keep belts tight enough to prevent slippage. Belts can be ruined very quickly if allowed to slip in the grooves of a sheave for any length of time. Excessive heating of a sheave is a sign of belt slippage. New belts will stretch slightly after the first run-off. Check tension frequently.

Open the clean-out doors in the bottom of the clean grain and tailings elevators and check tension of elevator chains—see page 64 for adjustments. It is a good plan to check the chain tension every day of operation.

Be certain all shafts turn freely.

After 50 hours of operation, drain the oil from the transmission and final drives. Fill with oil as specified in the lubrication section of this manual.

Follow the lubrication instructions and charts closely.

ENGINE

Your combine was shipped from the factory with a special "breaking-in" oil in the crankcase and hydraulic oil reservoir.

Do not allow the engine to operate at slow idle for any prolonged period as part of a break-in procedure. Doing so does not permit good piston ring seating and may promote oil consumption in the future.

After 20 hours of operation, drain the special "breaking-in" oil from the crankcase and hydraulic system. Replace the engine oil filter and clean the hydraulic reservoir oil filter (on combines equipped with power steering). Fill with the proper viscosity of oil as specified in the lubrication section of this manual.

BEFORE-OPERATION CHECKS AND ADJUSTMENTS

Careful inspection and service of the combine before starting work each day will prevent needless delays and breakdowns in the field. Make the following checks and adjustments:

1. Lubricate combine according to the lubrication charts.

2. Fill gasoline tank with a good grade of regular gasoline (capacity of tank is 25 U. S. gallons).

CAUTION: Do not fill tank while engine is running or when near an open flame.

3. Check water level in radiator. Fill with rain water, if available. Do not use water containing alkali. **CAUTION: If combine is being operated at temperatures below 32° F., refer to "Cold Weather Operation," page 17.** Add water or anti-freeze slowly until level is 1-1/2 inches below filler neck.

4. Check tire inflation. See tire inflation chart, page 76.

5. Service air cleaner, see page 25.

6. Check oil level of hydraulic unit, see page 28.

7. Check oil level of crankcase, see page 25.

8. Check friction drag adjustment for choke and throttle controls. See page 97.

9. Open the doors at bottom of elevators and leave them open until combine is started.

10. Inspect belts and chains for proper tension and alignment. See that there are no loose bolts or missing cotter pins.

STARTING THE ENGINE

Before starting a new engine, see the instructions on this page and page 26, regarding the break-in period and viscosity of oil in crankcase.

1. Make certain the separator, cutting platform, and grain tank unloading auger throw-out levers are disengaged and that the transmission is in neutral.

2. If engine has not been operated for a period of time or the gasoline tank has run dry, work fuel pump priming lever up and down to force gasoline into carburetor.

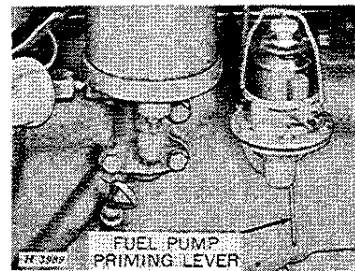

STARTING THE ENGINE—Continued

NOTE: After priming fuel pump, be sure the priming lever is in the "down" position. If the priming lever is left in the "up" position, the fuel pump is inoperative.

3. Turn ignition switch on. Move throttle lever one-quarter forward. Move choke lever all the way forward; then press starter button. After engine runs a few revolutions, move choke control rearward. Set engine at slow idle speed by moving idle control lever all the way rearward.

4. Check oil pressure gauge to see if it is registering pressure.

5. Do not place engine under load until properly warmed up.

STOPPING THE ENGINE

1. Set engine at slow idle speed and allow engine to operate at this speed for a few minutes before stopping. Turn off ignition.

STARTING THE COMBINE

1. Look around and make sure no one is standing near enough to the combine to touch any moving parts. Warn everyone to stand clear.

2. When engine is properly warmed up, pull separator throw-out lever back to engage the separator. Move throttle lever all the way forward.

3. Check the speed of beater behind the cylinder with a speed indicator. Beater should operate at 650 rpm with separator empty and not under load. If beater speed is not correct, adjust governor setting (see page 90).

4. Test operation of hydraulic control for adjusting cutting platform height.

5. Test operation of grain tank unloading auger.

6. Test operation of hydraulic selective ground speed control.

7. Check brakes to see that they are in proper working order.

8. Inspect entire combine again, making sure all units are working properly.

9. Disengage separator, then close doors at bottom of elevators.

SELECTING PROPER GROUND SPEED

Selecting the proper ground speed is one of the most important factors in combining. Too fast a ground speed causes overloading, resulting in loss of grain. Too slow a ground speed means the full capacity of the combine is not being used. Also, traveling over rough ground at high speed causes extra wear and possible damage to the combine.

The ground speed of the combine can be very closely controlled by using the selective ground speed drive in conjunction with different transmission speeds. The table on page 4 shows the range of speeds that can be obtained in each transmission range by means of selective ground speed control. Select the best transmission speed range; then, with the selective ground speed control lever, adjust the ground speed to meet field conditions exactly.

SPEED OF VARIOUS UNITS (Fast Idle—No Load)

Auger, Platform.....	163 rpm
Beater Behind Cylinder...	650 rpm
Cylinder (Normal Operating Speed at Fast Idle—No Load).....	1075 rpm Regular; 1056 rpm Edible Bean; 894 rpm Rice
Cylinder (Extreme Low) (3/4" Pitch Drive Chain)	394 rpm
Cylinder (Extreme High) (3/4" Pitch Drive Chain).	1075 rpm
Cylinder (Extreme Low) (1" Pitch Drive Chain— with Special 59-Tooth Sprocket).....	176 rpm
Cylinder (Extreme High) (1" Pitch Drive Chain)..	1056 rpm
Elevator, Tailings.....	288 rpm
Elevator, Clean Grain.....	309 rpm
Engine.....	2500 rpm
Fan (Normal Operating Speed).....	620 rpm
Fan (Extreme Low).....	593 rpm
Fan (Extreme High).....	810 rpm
Feeder House Conveyor Drive Shaft.....	231 rpm
Ground Travel Speeds....	(See page 4)
Reel.....	13 to 45 rpm
Shoe Crank.....	288 rpm
Straw Walker.....	208 rpm
Knife Speed.....	440 strokes per minute

CROSS-SECTIONAL VIEW OF JOHN DEERE 45 COMBINE

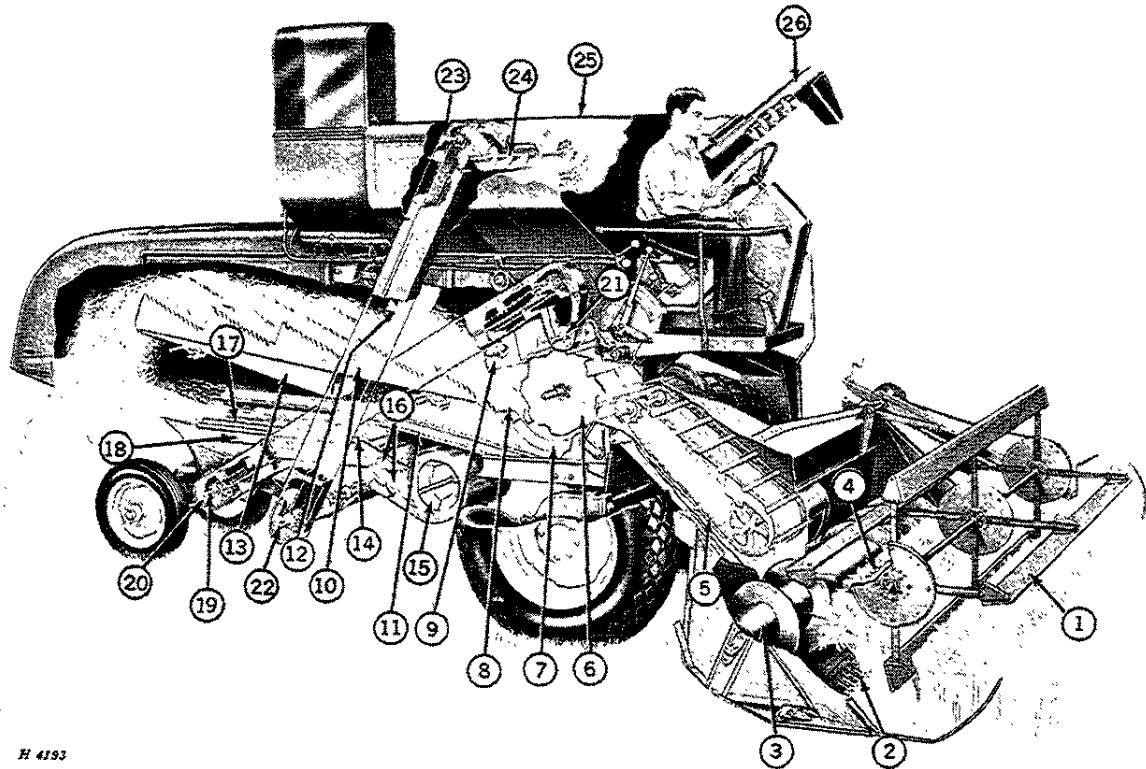

H 4193

This cutaway view shows how grain and straw are handled from cutter bar on through separator.

The reel (1), divides grain and holds it to cutter bar (2), until cut. The auger (3) carries grain from both ends of platform to center of auger (4). Retracting fingers in auger beater (4), take material and feed it to feeder conveyor chain (5). The chain (5), delivers grain to rasp-bar or spike-tooth cylinder (6).

As grain travels between cylinder (6), and concave (7), over grate fingers (8), and back against separating beater (9), the greater part of separating takes place. Separating beater (9) strips straw from the cylinder (6), deflects grain through finger grates (8), and passes straw onto the straw walkers (10).

Most of the grain falls through concave grate (7) and fingers (8) onto grain conveyor (11). Straw and remaining loose grain are passed along to the straw walkers (10). Curtain (12) keeps grain from being thrown over. On its outward movement, straw is

agitated by straw walkers (10). The remaining grain falls through openings in walkers and flows back through straw walker grain return pans (13) onto solid scalper (14). Straw is dropped off end of the straw walkers and out separator. The straw can be spread by straw spreader (special equipment) or broken up by straw chopper (special equipment).

After grain and chaff leave conveyor, (11) a blast of air from fan (15), through adjustable windboards (16), is directed against chaffer (17), and sieve (18). The air blast, with aid of sieve agitation, blows chaff away and moves tailings to tailings auger (19). The tailings auger (19) carries tailings to tailings elevator (20), which conveys them through cross auger (21), to center of cylinder (6), for rethreshing.

Clean grain after dropping through sieve (18), is carried by clean grain auger (22), to elevator (23). Elevator (23) delivers clean grain to tank loading auger (24). The loading auger (24) distributes grain evenly to grain tank (25). Grain tank unloading auger is (26).

**FOR YOUR OWN PROTECTION-
DON'T TAKE A CHANCE!**

FUNDAMENTALS OF COMBINE HARVESTING

Combining has proved to be the most economical, easiest, and fastest method of harvesting. This combine can be quickly adjusted to harvest almost any crop under any condition. On the following pages, you will find information about speeds, settings, and special equipment that will enable you to do a first-class job of harvesting your crop.

The one most important factor in harvesting is for the operator to have a thorough understanding of the fundamentals of combine operation.

These fundamentals in brief are:

1. Be sure crop is in condition to thresh—moisture content not too high—straw not too green, etc.

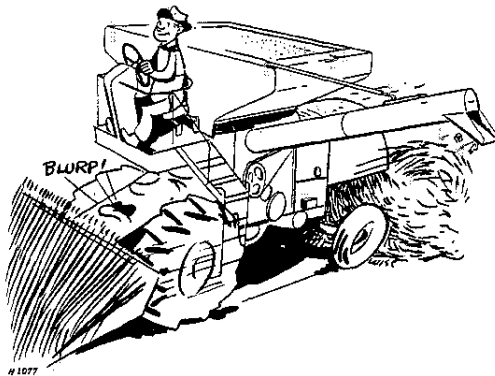

Don't Overload the Combine

2. In making the first round of the field, keep the combine forward speed as slow as possible to reduce the volume of material entering the combine. Always run the engine at full throttle to keep the combine mechanism up to full speed, thus guarding against slugging and clogging. Use the selective ground speed drive to obtain slower travel speed or shift to a lower gear if necessary—but do not throttle down the engine.

3. Select a ground speed that will not overload the combine.

4. See that cylinder is operating at the correct speed. Engine should be in good condition—governor should be properly set and responsive enough to accelerate quickly if an overload occurs.

5. Keep the cylinder speed as low as possible and concave clearance as high as possible to remove the maximum amount of grain from head without breaking up the straw excessively. Maintain correct beater speed to guard against wrapping of straw on beater.

6. Cut the crop as high as possible without excessive loss of low grain heads. If the straw is down and tangled, it may be desirable to use lifting guards. Slow travel speed is imperative.

7. Adjust the reel position and speed for even feeding.

8. Regulate adjustable chaffer openings to pass the grain or seed to the lower sieve before it has passed over two-thirds the length of chaffer without admitting too much coarse material.

9. Close adjustable sieve as far as possible without carrying clean grain into the tailings auger.

10. If material loads up on front of chaffer, adjust upper windboard to throw blast to front of shoe.

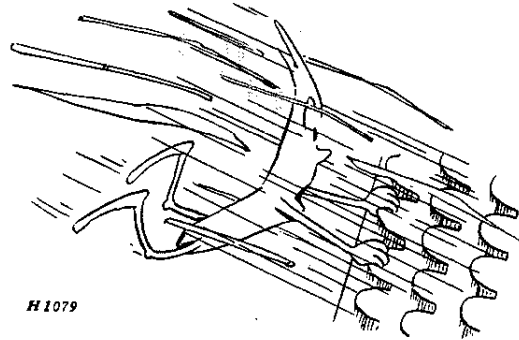

H 1079

Use Proper Amount of Blast

11. Use as much air as possible without blowing over clean seed. If the grain or seed is unusually light, it may be necessary to reduce the volume of air. In heavy seeds, increase the volume of air. *NOTE: The volume of air is regulated by the cleaning fan speed.*

12. Keep amount of tailings as low as possible.

OPERATING SUGGESTIONS.

The degree of satisfaction given by this or any other combine depends upon the carefulness of the operator. Once the combine has been adjusted to meet the crop condition, the rest is up to the operator.

Don't start combining until the crop is ripe. The natural tendency of the owner of a new combine is to try out his new machine as soon as possible. This results in many new combines being started in the field before the crop is ready for combining.

Unless crop drying equipment is available, a crop should not be combined until it is dead ripe. If the threshed grain feels damp or is easily dented with the fingernail, the moisture content is usually too high for safe storage.



Suggest:

If the above button click is invalid.

Please download this document

first, and then click the above link

to download the complete manual.

Thank you so much for reading

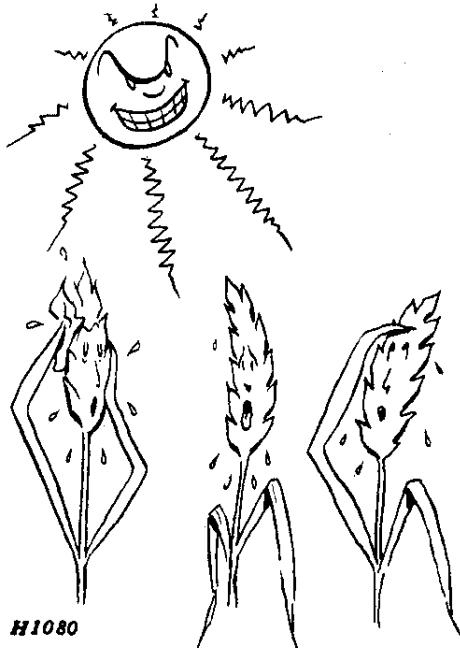

H1080

Wait Until the Crop Is Dry

Grain crops containing 14% moisture or less are usually considered dry enough for safe storage. A John Deere Moisture Meter for checking moisture content of grain and a portable Grain Dryer can be purchased from your John Deere dealer.

PREPARING THE FIELD

Proper Preparation of Field for Combining Will Mean Less Trouble and More Profitable Operation.

In fields where small grain follows corn in the rotation of crops, take special care before seeding to clean up or cover cornstalks and large corn roots. They can be very troublesome if the crop goes down.

When a cornstalk or root hooks onto the point of a guard, a great deal of grain is pushed ahead and run down. It is then usually necessary to stop, back up, and clean off the cutter bar before going ahead. If the cutter bar is raised to avoid stalks and roots, loss of some grain results.

A little extra work done when preparing the field for the small grain crop will pay big dividends when harvest time rolls around.

OPERATION IN WEEDY CONDITIONS

Combining in fields where weeds are numerous is particularly troublesome as they tend to gum up the sieves. Also, the moisture in the seeds is imparted to the grain.

*Prepare the Field*

Weeds should be disposed of quickly and not be broken up any more than necessary.

The following suggestions will help while operating in weedy conditions.

1. Cut the grain as high as possible.
2. Try to avoid weeds and undergrowth.
3. Check to see that cylinder is operating at proper speed.
4. Use as much blast on shoe as possible without blowing over grain.
5. Lower rear end of chaffer.

HEIGHT OF CUT

The cutting platform has a cutting height range from 2 inches below wheel level to 31-3/8 inches above wheel level on grain combines (13.6-26 tires), and from 3 inches below wheel level to 30-3/8 inches above wheel level on rice combines.

Cut just low enough to get all grain heads. Watch the height and condition of grain and continually raise and lower the cutting platform to meet conditions.

If the crop is extremely heavy and badly down, it may be necessary to cut less than a full swath or reduce travel speed.

BE ALERT!

Listen for the warning of the clutches slipping. Also, listen to the engine for any evidence of slowing down caused by cylinder starting to slug. Immediately stop the forward travel of the combine and disengage the platform drive. This will permit the separator to clear.

<https://www.ebooklibonline.com>

Hello dear friend!

Thank you very much for reading.

Enter the link into your browser.

The full manual is available for immediate download.

<https://www.ebooklibonline.com>