

45 COMBINES



OPERATORS MANUAL

45 COMBINES

OMH62357 K5 English

OMH62357 K5

LITHO IN THE U.S.A.
ENGLISH



TO THE PURCHASER

The combine you have purchased has been carefully designed and manufactured to provide years of dependable, economical service.

To further insure trouble-free service we recommend that you follow closely all instructions concerning operation, lubrication, adjustments and service. Preventive maintenance has proved to be much more economical than corrective maintenance. Should you require information not covered in this manual, consult your John Deere dealer.

KEEP YOUR COMBINE A JOHN DEERE COMBINE

Genuine John Deere Parts fit properly and insure satisfactory service because they are made from the original patterns and from the same materials as used in new machines. Should your combine require replacement parts, go to your John Deere dealer where you can obtain Genuine John Deere Parts—accept no substitutes.

ATTACHMENTS

In addition to the equipment furnished with your combine, there are attachments available to help you do a better job in a special crop or condition. These attachments, illustrated and described in the attachment section, are available from your John Deere dealer.

LOCATION REFERENCE

"Right-hand" and "left-hand" sides are determined by facing in the direction the combine will travel when in use.

Radiator end of the engine is referred to as the "front," flywheel end as the "rear."

SERIAL NUMBERS

Your combine, cutting platform, axle, and engine have serial numbers.

When ordering parts, always furnish the model and serial numbers as given on the serial number plates. By doing so, you will assist your John Deere dealer in giving you prompt, efficient service.

The combine serial number is on a plate located on the support bracket at the rear of the fuel tank.

The engine serial number is on a plate located on top of the flywheel housing.

The axle serial number is on the top, left-hand end of the axle tube.

The cutting platform serial number is on a plate located on the outside of the right-hand platform divider.

Record these Serial Numbers in the space provided below.

Combine serial no. _____

Engine serial no. _____

Axle serial no. _____

Cutting platform serial no. _____

Date purchased _____

CONTENTS

<i>Specifications</i>	2
<i>Controls and instruments</i>	6
<i>Operation</i>	8
<i>Safety suggestions</i>	18
<i>Fuels and lubricants</i>	19
<i>Lubrication and periodic service</i>	22
<i>Adjustments and service</i>	34
<i>Trouble Shooting</i>	59
<i>Engine service</i>	66
<i>Attachments</i>	86
<i>Index</i>	94

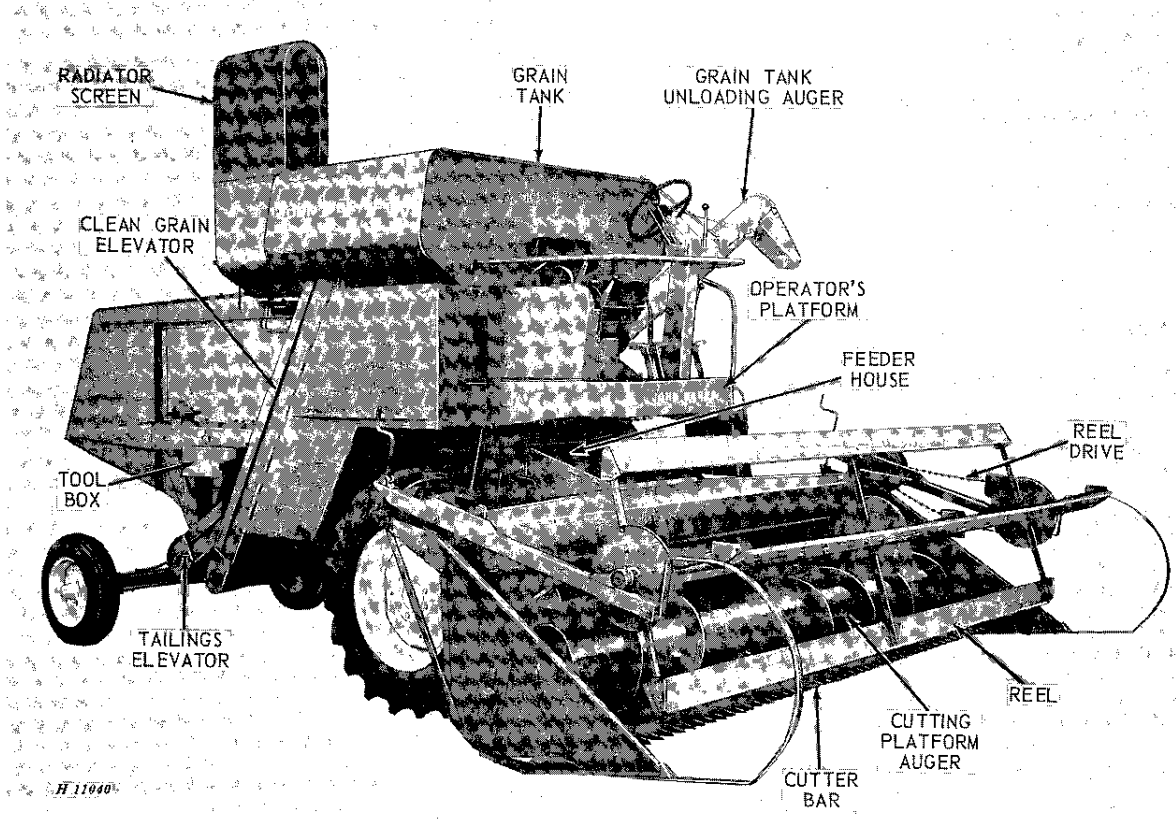

Right-Hand Front View - John Deere 45 Grain Tank Combine

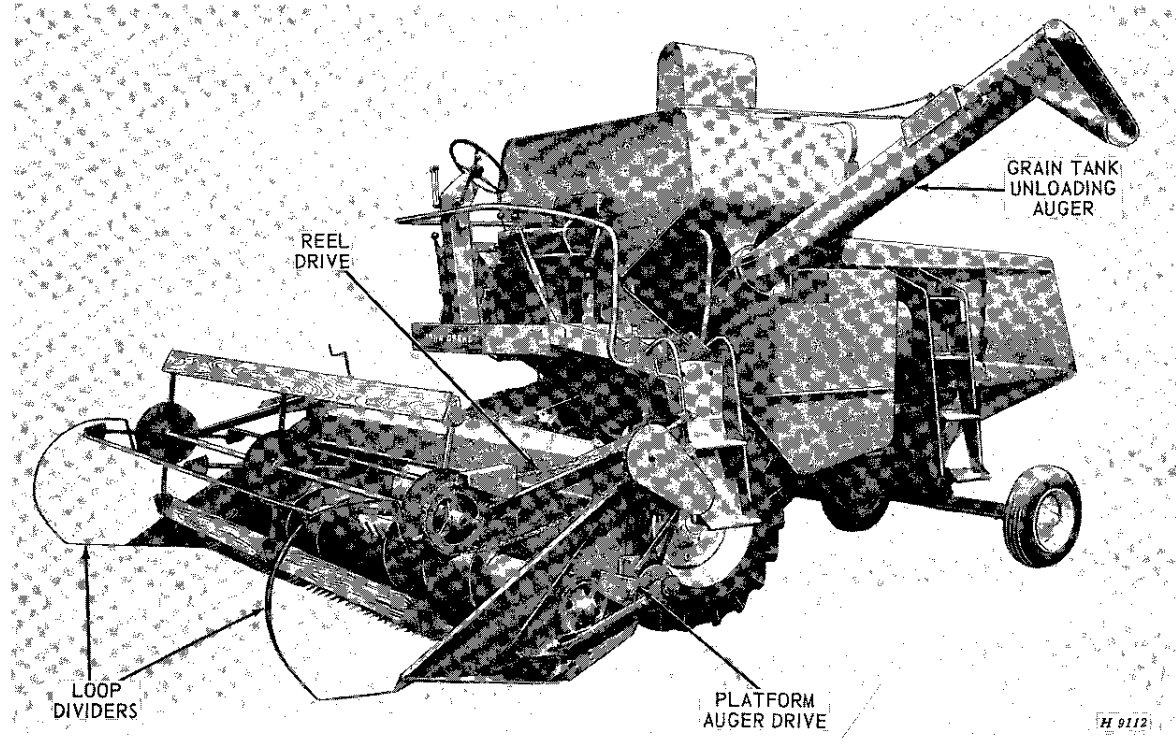

Left-Hand Front View - John Deere 45 Grain Tank Combine

<https://www.ebooklibonline.com>

Hello dear friend!

Thank you very much for reading.

Enter the link into your browser.

The full manual is available for immediate download.

<https://www.ebooklibonline.com>

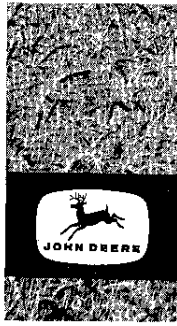

SPECIFICATIONS

COMBINE

CUTTER BAR

Width of cut 8-ft. 6-in., 10-ft. 6-in.,
or 12-ft. 6-in.
Length of cutter bar 8-ft., 10-ft., or 12-ft.
Type of knife sections Heavy-duty
overserrated

REEL

Drive Chain
Number of slats 4 regular; 3, 6, or 8 special
Diameter of reel 32-in. or 40-in.
Speed range 13 rpm to 45 rpm

CUTTING PLATFORM

Type of feed Auger
Range of cutting height:
Grain 2-in. below wheel level
to 31-3/8-in. above
Rice 3-in. below wheel level
to 30-3/8-in. above
Height control 2 hydraulic cylinders

CUTTING PLATFORM AUGER

Diameter 18-in.
Diameter of auger tube 10-in.
Type of auger fingers Round retracting

CYLINDER

Type Rasp-bar or spike-tooth
Width 26-in.
Diameter 22-in.
Number of bars 8 Rasp-bars or 10 spike-
tooth bars (five 12-tooth
bars and five 13-tooth
bars)

Drive Roller chain
Speed range 175 rpm to 1095 rpm

CONCAVE

Type 12-bar open type or spike-tooth type
Width 26-in.

BEATER (Behind the cylinder)

Type Wing
Width 26-in.
Diameter 12-in.
Speed 650 rpm

SEPARATOR

Type Grain conveyor, straw walker
Width 26-in.
Length of separating surface 130-in.
(Straw walker pans extended)
Area of separating surface 3380 sq. in.

GRAIN CONVEYOR

Type Slat
Drive Chain

CLEANING FAN

Type 5-bladed undershot
Drive V-belt
Speed range 540 rpm to 750 rpm

CHAFFER

Type Adjustable
Width 22-3/4-in.
Length—with tailings finger bar 54-3/4-in.
Area 1246 sq. in.

SIEVE

Type Adjustable
Width 22-3/4-in.
Length 43-7/8-in.
Area 1000 sq. in.

TOTAL CLEANING AREA 2246 sq. in.

STRAW WALKERS

Number Three
Width 7-7/8-in.
Length—with pans extended 113 in.
Area 2938 sq. in.
Number of steps Five
Drive V-belt
Bearings Oil-soaked maple
Extension pans One on each walker

GRAIN TANK

Capacity 50-bushel, approx. (Type and
condition of crop will de-
termine actual volume)

BRAKES

Type Individual, mechanical disk-type

TRANSMISSION Automotive—3 speeds for-
ward, 1 reverse

STEERING Power

WEIGHTS AND DIMENSIONS

Shipping length 17 ft. 6 in.
Shipping width 8 ft. (approx.)
Grain combine with 10-foot cutting
platform 7050 lbs. (approx.)
Rice combine with 10-foot cutting
platform 7350 lbs. (approx.)

TIRE SIZES AND WHEEL TREAD DIMENSIONS

Main Wheel Tire Sizes	Center-to-Center Wheel Tread		Guide Wheel Tire Sizes	Regular Axle	Center-to-Center Wheel Tread	
	Rim Dished In	Rim Dished Out			OPTIONAL	
					60 In. Wide Axle	74 In. Wide Axle
13.6-26 (6-ply)	77 in.	89 in.	5.50-16 (4-ply)	42 in.	59 in.	73 in.
14.9-26 (6-ply)	78 in.	88 in.	6.00-16 (4-ply)	44 in.	61 in.	75 in.
16.9-26 (6-ply)	80 in.	86 in.	6.50-16 (4-ply)	44 in.	61 in.	75 in.
18.4-26 (6-ply)	81 in.	7.50-16 (4-ply)	44 in.	61 in.	75 in.
			7.50-18 (4-ply)	43 in.	60-1/4 in.	74-1/4 in.

NOTE: Guide wheels may be interchanged on the various rear axles.

GROUND SPEED RANGE

GRAIN DRIVE

RICE DRIVE

13.6-26 Tires—Standard			18.4-26 Tires—Standard		
	(Min.)	(Max.)		(Min.)	(Max.)
1st Gear	.7	1.8	1st Gear	.6	1.7
2nd Gear	1.5	3.9	2nd Gear	1.4	3.7
3rd Gear	3.5	9.2	3rd Gear	3.4	8.7
Reverse	1.6	4.0	Reverse	1.5	3.8

14.9-26 Tires—Optional			16.9-26 Tires Optional		
	(Min.)	(Max.)		(Min.)	(Max.)
1st Gear	.7	1.8	1st Gear	.7	1.9
2nd Gear	1.5	4.0	2nd Gear	1.6	4.1
3rd Gear	3.7	9.5	3rd Gear	3.7	9.7
Reverse	1.6	4.2	Reverse	1.7	4.3

CAPACITIES (APPROX.)

Fuel tank gasoline	25 U.S. gallons	Hydraulic unit (including hydraulic oil lines and cylinders) . . .	11-1/2 U.S. quarts
diesel	24 U.S. gallons	Transmission	10 U.S. pints
Cooling system	14 U.S. quarts	Final drives (2)	4-1/4 U.S. pints (In each)
Engine crankcase	7 U.S. quarts		

COMBINE DIMENSIONS—OVER-ALL

NOTE: Dimensions given for combine equipped with 13.6-26 main wheel tires and 5.50-16 guide wheel tires.

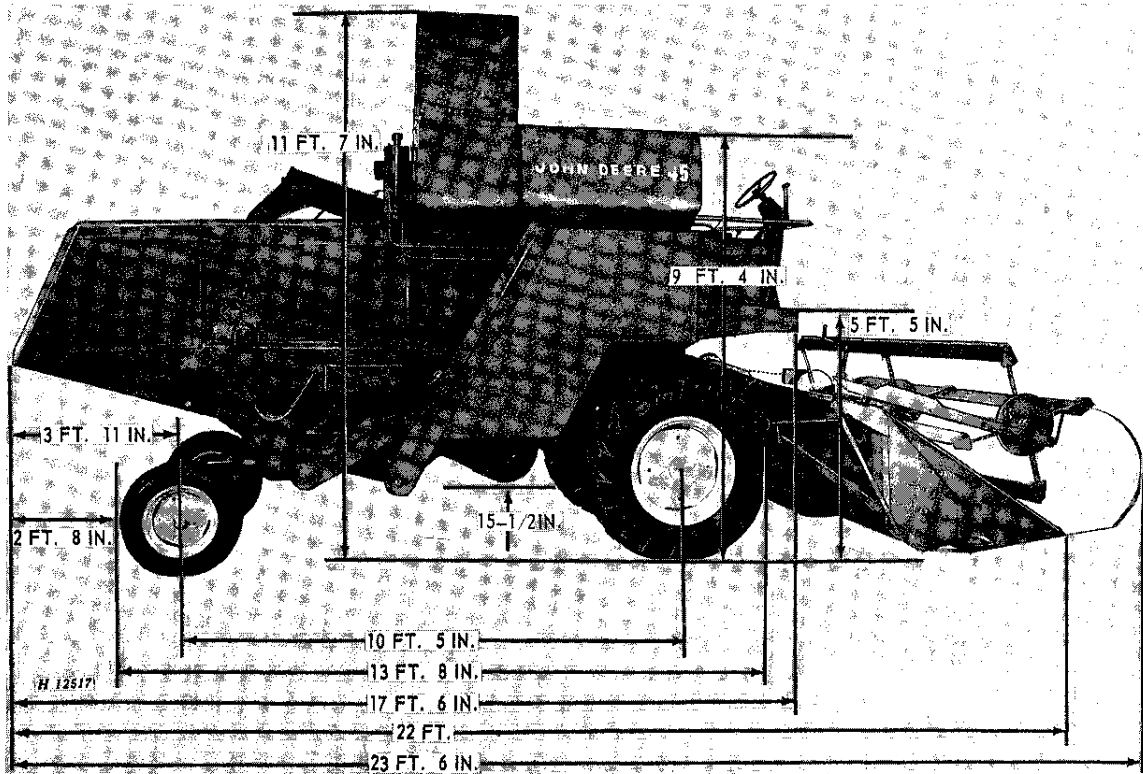
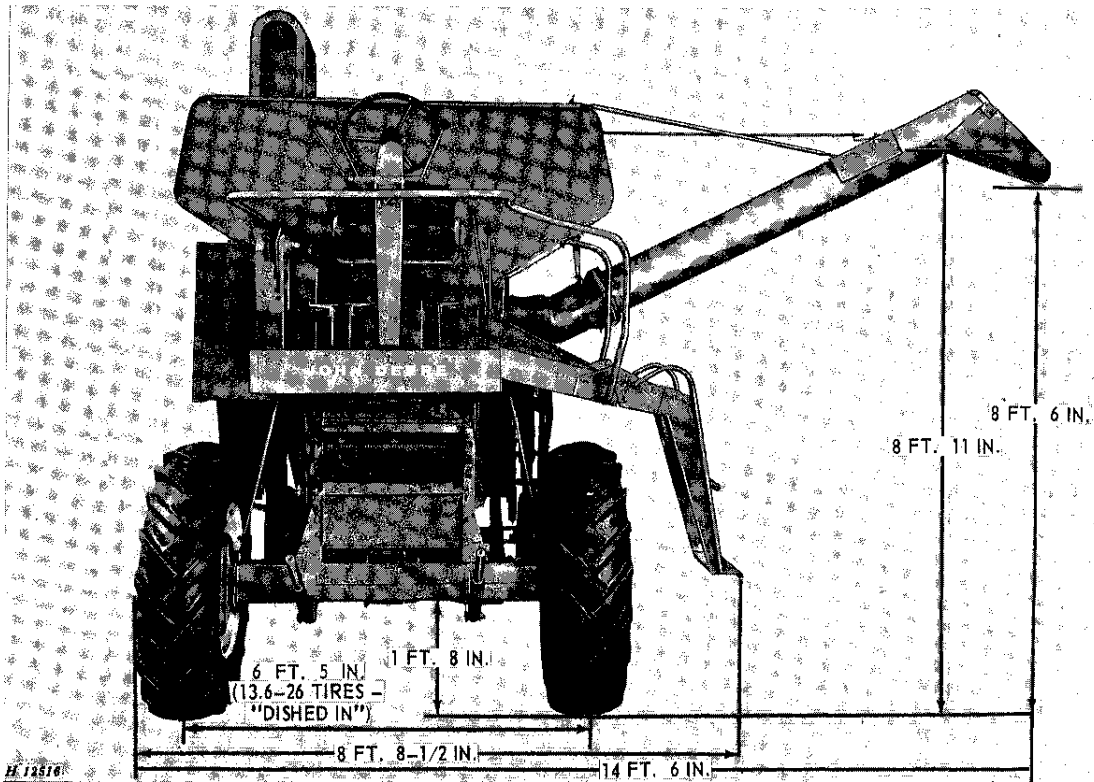

NOTE: When combine is equipped with cab, storage height above grain tank is increased approximately 16 inches.

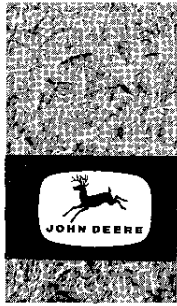

CONTROLS AND INSTRUMENTS

Before attempting to operate your new combine, become familiar with the location and purposes of its controls and instruments. Study these pages carefully, regardless of your previous combine experience.

CONTROLS

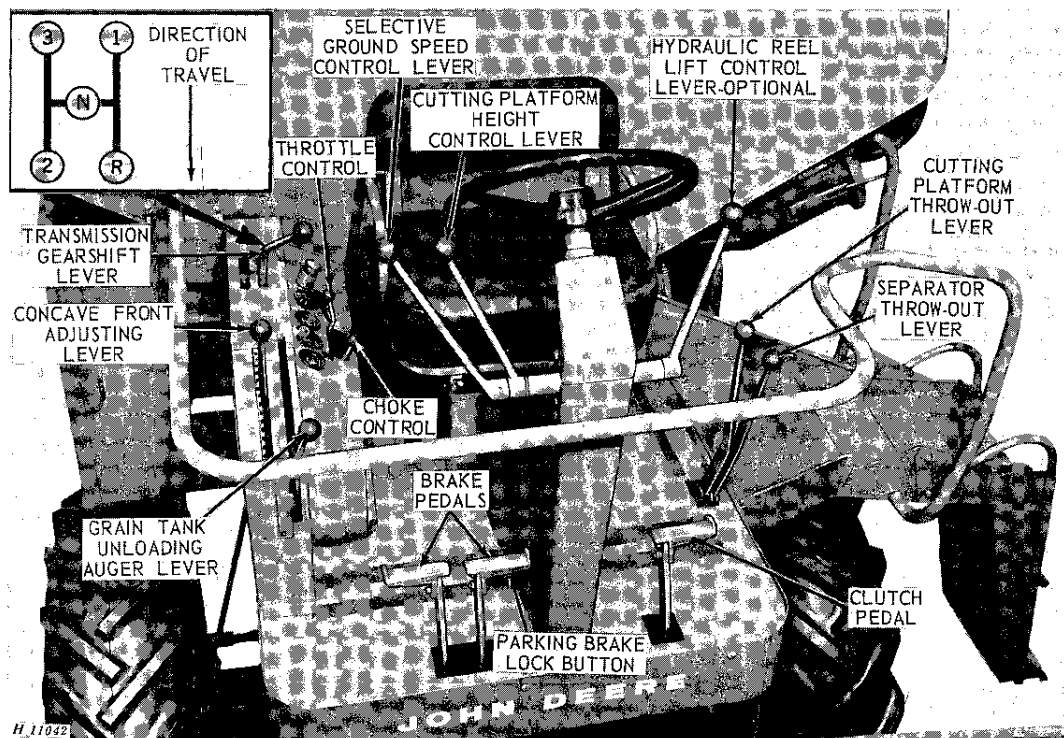

The combine controls are located on the operator's platform within easy reach of the operator. Those controls whose purpose and function are obvious will not be explained.

TRANSMISSION GEARSHIFT LEVER

There are three speed ranges forward and one reverse. Positions of gearshift lever for different transmission speed ranges are shown by diagram.

CAUTION: Be certain the gearshift lever is in neutral position and clutch pedal is depressed before starting engine.

GRAIN TANK UNLOADING AUGER LEVER

Move lever forward to disengage auger, rearward to engage auger. Grain tank unloading drive and separator drive are independent. If engine is running, separator can be stopped without affecting unloading of grain tank.

SEPARATOR THROW-OUT LEVER

To disengage separator, push lever forward; to engage, pull lever rearward.

SELECTIVE GROUND SPEED CONTROL LEVER

To increase ground travel speed within a selected transmission range, move lever forward.

SELECTIVE GROUND SPEED CONTROL LEVER – CONTINUED

To decrease ground travel speed, move lever rearward. Ground travel speeds from 0.7 to 9.2 mph (13.6-26 tires) are available at governed engine speed. Separator speed remains constant.

CUTTING PLATFORM HEIGHT CONTROL LEVER

This lever controls the height of the platform through a hydraulic mechanism. Platform height range is from 2 inches below wheel level to 31-3/8 inches above wheel level on grain combines and 3 inches below wheel level to 30-3/8 inches above wheel level on rice combines. Move lever forward to lower platform, rearward to raise platform. When released, lever automatically returns to neutral position and cutting platform remains at selected position. As a safety measure, cutting platform height cannot be changed unless engine is running.

PARKING BRAKE LOCK BUTTON

The parking brake lock button locks the brake so the combine cannot move if left unattended.

To engage, step on brake pedals and step on brake lock button.

To disengage, push brake pedals down; parking brake lock releases automatically.

Never attempt to move combine with parking brake lock engaged.

CUTTING PLATFORM THROW-OUT LEVER

To engage, pull lever rearward; to disengage, push lever forward.

CONCAVE FRONT ADJUSTING LEVER

Move lever forward to lower front of concave, rearward to raise front of concave.

THROTTLE LEVER

Move lever one quarter rearward when starting engine. Move lever all the way rearward for normal operation (fast idle); move lever all the way forward for slow idle.

CHOKE CONTROL (GASOLINE)

Move choke control all the way rearward when starting engine. After engine is started, and for normal operation, move choke control all the way forward.

INSTRUMENTS

KEY SWITCH

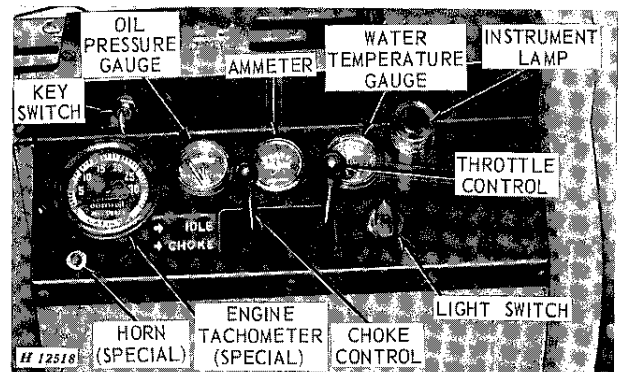

The key switch serves as a combination accessory switch, ignition lock, and starter key.

Turn key clockwise to start engine, counter-clockwise for accessories only. Turn key to vertical position to turn off; remove key to lock ignition.

LIGHT SWITCH

The three positions on the light switch are:

VERTICAL - To turn off all lights.

FIRST STOP - To turn on headlights, mast lamp and warning lamp.

SECOND STOP - To turn on headlights, mast lamp, warning lamp, taillamp and panel lamp.

WATER TEMPERATURE GAUGE

This gauge indicates the water temperature in the cooling system. Normal operating temperature is 160° to 219° F. (indicated by green band on dial). If 219° F. or above (indicated by red band on dial), stop engine and determine cause.

AMMETER

This gauge indicates the rate of charge or discharge of the battery. If ammeter shows discharge for an extended period during normal operation, check for a ground, short circuit or faulty regulator. If ammeter shows high charge continually, inspect for low battery, faulty connections, low battery water or bad regulator.

OIL PRESSURE GAUGE

This gauge indicates the pressure of engine lubricating oil. Oil pressure will vary slightly, but with recommended oil it should read normal (indicated by green band on dial) at full governed speed. If needle registers in red band on dial, stop engine and determine cause.

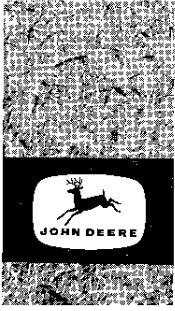

OPERATION

FUNDAMENTALS OF COMBINE HARVESTING

The most important factor in harvesting is for the operator to have a thorough understanding of the fundamentals of combine operation.

These fundamentals in brief are:

Be sure crop is in condition to thresh—moisture content not too high—straw not too green, etc.

In making the first round of the field, keep the combine forward speed as slow as possible to reduce the volume of material entering the combine. Always run the engine at full throttle to keep the combine mechanism up to full speed, thus guarding against slugging and clogging. Use the selective ground speed drive to obtain slower speed, or shift to a lower gear if necessary—but do not throttle down the engine.

Select a ground speed that will not overload the combine.

Engine should be in good condition—governor should be properly set and responsive enough to accelerate quickly if an overload occurs.

Keep the cylinder speed as low as possible and concave clearance as high as possible to remove the maximum amount of grain from grain heads without breaking up the straw excessively.

Cut the crop as high as possible without excessive loss of low grain heads. If the straw is down and tangled, it may be desirable to use lifting guards. Slow travel speed is imperative.

Adjust the reel position and speed for even feeding.

Open adjustable chaffer as far as possible without admitting too much coarse material into the tailings auger.

Open shoe sieve as far as possible to prevent clean grain being recirculated.

Use as much air as possible without blowing over clean seed. If the grain or seed is unusually light, it may be necessary to reduce the volume of air. In heavy seeds, increase the volume of air.

Keep amount of grain in tailings as low as possible.

OPERATING SUGGESTIONS

Don't start combining until the crop is ripe.

Unless crop drying equipment is available, crop should not be combined until it is dead ripe. If the threshed grain feels damp or is easily dented with the fingernail, the moisture content is usually too high for safe storage.

Grain crops containing 14 per cent moisture or less are usually considered dry enough for safe storage. A John Deere Moisture Meter for checking moisture content of grain and a portable Grain Dryer may be purchased from your John Deere dealer, or arrangements may usually be made at the local grain elevator for necessary moisture tests and drying if necessary.

OPERATING IN WEEDY CONDITIONS

Combining in fields where weeds are numerous is particularly troublesome as they tend to plug the sieves. Also, the moisture in the seeds is imparted to the grain.

The following suggestions will help while operating in weedy conditions:

Cut the grain as high as possible to avoid weeds and undergrowth.

Be certain the cylinder is operating at proper speed.

Use as much air blast on the shoe as possible without blowing over grain.

HEIGHT AND WIDTH OF CUT

Note very carefully the condition of the crop and adjust the cutting platform height so just enough of the straw is cut to get all the grain. If the crop is extremely heavy and badly down, it may be necessary to cut less than a full swath or to reduce travel speed.

HOLD DOWN THE GROUND SPEED

Excessive travel speed is one of the greatest causes of trouble in combining. Traveling at too high a ground speed causes overloading, resulting in a loss of grain.

Also, traveling at an excessively high speed over rough ground causes extra wear and damage to parts not incurred when the combine is operated at a more reasonable speed.

KEEP STEADY, SMOOTH ENGINE SPEED

Any fluctuation in engine speed is reflected in the speed of the separator. Uneven speed results in loss of grain, inferior threshing and, in extreme cases, complete plugging of the combine. Take every precaution to maintain the correct uniform speed.

By rounding the corners in the field, you maintain more uniform speed when turning.

When stopping, wait until material in the combine is cleaned out before disengaging separator throw-out lever.

BEFORE-OPERATION CHECKS AND ADJUSTMENTS

Careful inspection and service of the combine before starting work each day will prevent needless delays and breakdowns in the field. Make the following checks and adjustments:

Fill fuel tank with a good regular grade of gasoline or diesel fuel.

CAUTION: Do not fill tank while engine is running or when near an open flame.

Check water level in radiator. Fill with clean rain water if available. Do not use water containing alkali. It is recommended that Summer Engine Coolant Conditioner be used during

warm weather. Refer to HOTWEATHEROPERATION, page 78. If combine is being operated at temperature below 32°F., refer to COLD WEATHER OPERATION, page 15.

Add water or coolant slowly until the level is approximately 1 inch below the bottom of the filler neck.

Lubricate the combine, final drive, and engine completely and check oil level of hydraulic unit and transmission. See LUBRICATION section, page 22.

Check tire inflation. See tire inflation chart, page 57.

Open the doors at bottom of elevators and unloading auger and leave them open until combine is started.

Inspect belts and chains for proper tension and alignment. Be certain there are no loose bolts or missing cotter pins.

OPERATOR'S SEAT

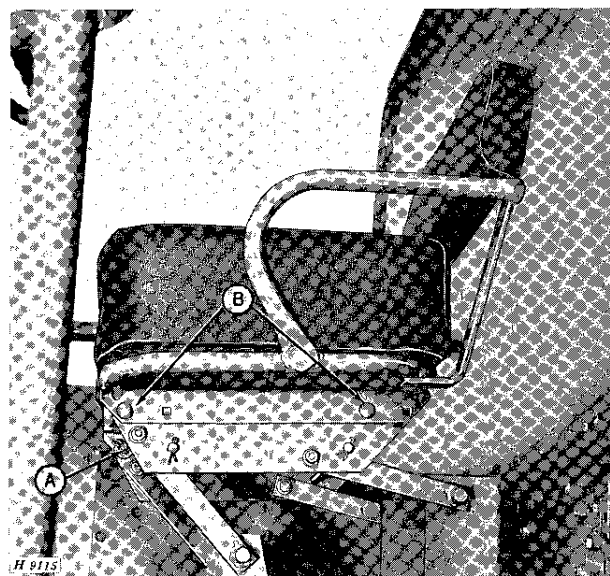

The operator's seat may be moved forward and rearward and may also be folded back into a vertical position against the grain tank should the operator desire to work in a standing position.

Remove four wing nuts 'A' from bolts 'B' and remove bolts from frame. Move seat forward until holes match up and replace bolts and nuts. Reverse the procedure to move seat rearward.

OPERATOR'S PLATFORM HINGED LADDER

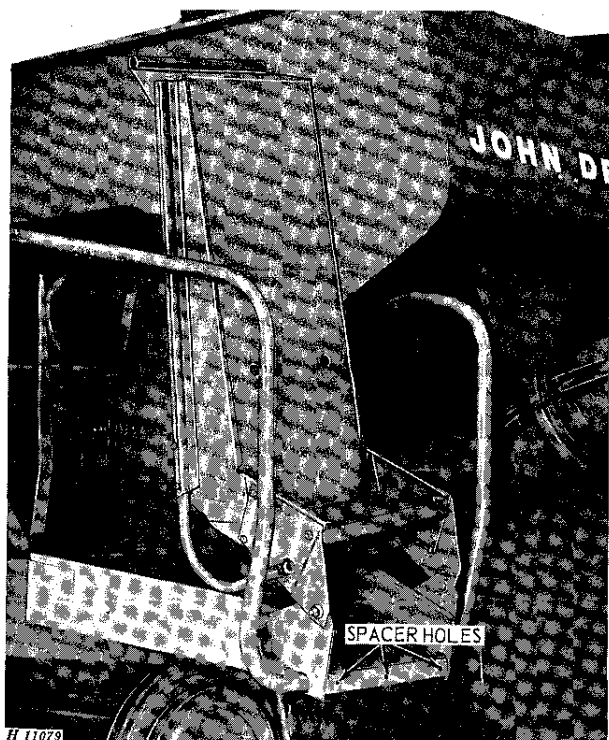

Hinged Ladder in Retracted Position

CAUTION: When lowering the hinged ladder always be certain that no one is standing where he might be struck by the ladder.

When combine is equipped with 14.9-26 or 16.9-26 tires with rims dished out, add three 1/2 x 1-inch machine bolts to spacer holes with enough 1/8-inch washers under bolt heads to provide a minimum 5/8-inch spacing. This allows ladder to clear tires.

COMBINE AND ENGINE BREAK-IN

COMBINE

Check all V-belt drives carefully for proper alignment and tension - see pages 58 and 75. Belts can be ruined very quickly if allowed to slip in the grooves of a sheave for any length of time. Excessive heating of a sheave is a sign of belt slippage. Keep belts tight enough to prevent slippage. New belts will stretch slightly after the first runoff. Check tension frequently.

Open the clean-out doors in the bottom of the clean grain and tailings elevators and check tension of elevator chains—see page 50 for adjust-

ments. Check the chain tension every day of operation.

Be certain all shafts turn freely.

After 50 hours of operation, drain oil from the transmission. Fill with oil as specified in LUBRICATION section of this manual. Follow other lubrication instructions and charts closely.

ENGINE

The engine was shipped from the factory with SAE 10W-30 oil in the crankcase. (Service DS for gasoline engines or Service DM for diesel engines).

Do not allow the engine to operate at slow idle for any prolonged period as part of break-in procedure. Doing this prevents the piston rings from seating and may promote future oil consumption.

After the first 20 hours of operation, drain the oil from the crankcase. Replace the engine oil filter and clean the hydraulic reservoir oil filter. Fill crankcase with the proper viscosity of oil as specified in the LUBRICATION section of this manual.

STARTING THE ENGINE

Before starting the engine, make certain the separator, cutting platform, and grain tank unloading auger throw-out levers are disengaged and transmission is in neutral.

GASOLINE ENGINE

If the gasoline engine has not been operated for a period of time, or the fuel tank has run dry, prime fuel pump lever up or down to force gasoline into carburetor.

NOTE: After priming fuel pump, be sure the priming lever is in the "down" position. If the priming lever is left in the "up" position, the fuel pump is inoperative.

Move throttle lever one-quarter open. Move choke lever all the way open. Depress clutch pedal and turn key as far clockwise as possible. After engine starts, release key and push choke control rearward. Check oil pressure gauge to make certain it is registering pressure; if not, stop engine and determine cause.

Release clutch and warm engine and transmission for five minutes at fast idle—no load. Do not operate combine during warm up.

DIESEL ENGINE

If the diesel engine has not been operated for a long period of time, or if the fuel tank has run dry, it is necessary to bleed the entire fuel system to remove air bubbles. See page 67 for bleeding procedure.

CAUTION: If possible, never let the fuel tank run dry.

Move throttle to one-quarter open, depress clutch pedal, and turn key as far clockwise as possible.

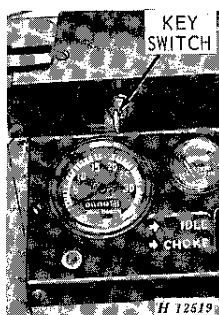

Diesel engines are equipped with the electrical combustion chamber pre-heaters called glow plugs, located above the fuel injectors. They are used when starting a cold engine, but need not be used when starting a hot engine. Heat glow plugs (no more than 30 seconds at a time) by turning the key switch clockwise as far as possible and cranking engine at the same time.

Diesel engines do not require a choking system.

If combine is equipped with primer pump, prime engine when necessary and heat glow plugs as specified in the chart below.

Primer Pump Chart

Temperature	Prime	Preheat Time
Warm engine	None	30 seconds
Above 32° F.	2 strokes	30 seconds
32° F. to 0° F.	3 strokes	30 seconds
Below 0° F.	4 strokes	30 seconds

NOTE: Do not prime more than specified in chart.

IMPORTANT: Lock plunger in place after using pump.

STOPPING THE ENGINE

GASOLINE ENGINE

Set engine at slow idle speed and allow engine to run at this speed for a few minutes before turning key switch off.

DIESEL ENGINE

Set engine at slow idle speed and allow engine to run at this speed until temperature gauge drops well into white range on dial. Move throttle to rear and turn off key.

CAUTION: Do not attempt to stop engine by turning off fuel supply at tank. Doing so will cause injection pump to run dry and damage internal parts.

STARTING THE COMBINE

CAUTION: Make certain no one is standing near enough to the combine to touch any moving parts. Warn everyone to stand clear.

When engine is properly warmed up, move separator throw-out lever forward to engage the separator. Push throttle lever all the way forward.

Check the speed of beater behind the cylinder (page 46) with a speed indicator. Beater should operate at 650 rpm with separator empty and not under load. If beater speed is not correct, adjust governor setting (see page 70).

Test operation of hydraulic control for adjusting cutting platform height.

Test operation of grain tank unloading auger.

Test operation of hydraulic selective ground speed control.

Check brakes to see if they are in proper working order.

Inspect entire combine again, making certain all units are working properly.

Disengage separator, then close doors at bottom of elevators.

SELECTING PROPER GROUND SPEED

The ground speed of the combine can be very closely controlled by using the selective ground speed drive in conjunction with different transmission speeds. The chart on page 3 shows the speeds that can be obtained in each transmission range by means of selective ground speed control. Select the best transmission speed range; then, with the selective ground speed control lever, adjust the ground speed to meet field conditions exactly.

TRANSPORTING

When transporting, drive combine under its own power or load it on a truck. Combine may be towed with caution. If combine is to be towed, remove the drive shafts between final drives and differential.

The width of the combine can be reduced by folding the unloading auger back along the separator and removing the cutting platform. The width can be further reduced by folding up hinged-type operator's platform ladder. The radiator screen can be hinged down to reduce the height.

Over-all dimensions are given on page 5.

If the cutting platform and feeder house are removed, the hydraulic cylinders must be wired or supported by support chains (special attachment) no closer to separator support channel than 14 inches. Damage may result to hoses if carried too close.

Clean out combine thoroughly before leaving one field and going to the next in order to reduce the spread of noxious weed seeds.

When through cutting in a field, sweep trash and straw from outside of combine, open doors at bottom of elevators and run combine until all straw, trash, and grain are removed from inside of combine before moving to the next field.

CAUTION: When driving the combine on a road or highway at night or during the day, use accessory lights and devices for adequate warning to the operators of other vehicles. In this regard check local governmental regulations. Various safety lights and devices are available at your John Deere dealer.

**SPEED OF VARIOUS UNITS
(Full Governed Speed—No Load)**

Auger, Platform	163 rpm	(regular)
Auger, Platform	179 rpm	(special)
Beater Behind Cylinder	650 rpm	
Cylinder (As Shipped From Factory)	1095 rpm	Regular
	1095 rpm	Edible Bean
	904 rpm	Rice
Cylinder (Extreme Low) (1" Pitch Drive Chain-with Special 59-Tooth Sprocket)	176 rpm	
Cylinder (Extreme High) (1" Pitch Drive Chain)	1095 rpm	
Elevator, Tailings	325 rpm	
Elevator, Clean Grain	325 rpm	
Engine	2590 rpm	
Fan (Regular)	696 rpm	
Fan (Extreme Low)	540 rpm	
Fan (Extreme High)	720 rpm	
Feeder House Conveyor Drive Shaft	231 rpm	
Ground Travel Speeds	(See page 3)	
Knife Speed	440 strokes per min.	
Reel	13 to 45 rpm	
Shoe Crank	288 rpm	
Straw Walker	208 rpm	

CUTTING PLATFORM HEIGHT

The cutting platform has a cutting height range from 2 inches below wheel level to 31-3/8 inches above wheel level on grain combines (13.6-26 tires), and from 3 inches below wheel level to 30-3/8 inches above wheel level on rice combines.

Cut just low enough to get all grain heads. Watch the height and condition of crop and continually raise and lower the cutting platform to meet conditions. If the crop is extremely heavy and badly down, it may be necessary to cut less than a full swath or reduce travel speed.

Listen for the warning of the clutches slipping. Also, listen to the engine for any evidence of slowing down caused by cylinder starting to slug. Immediately stop the forward travel of the combine and disengage the platform drive. This will permit the separator to clear.

SUGGESTED SETTINGS FOR COMBINING VARIOUS CROPS

(NOTE: These suggested settings are for average conditions. Different field conditions may make if necessary to change these settings.)

Crop	Cyl-inder RPM Range ⁺	Resp-Bar Cylinder to Concave Clearance		Spikes-Tooth Concave Arrangement T - Teeth OG - Open Grate			Snap-On Resp-Bar Concave Covers	Cleaning Sieve	Setting of Adjustable Cleaning Sieve	Setting of Chaffer	Cleaning Fan Speed Range
		Front	Rear	Front	Center	Rear					
Alfalfa	786 to 1095	1/4"	3/16"	T	T	T	4 to 8	Adjustable or Rd. Hole	Slightly Open	About 1/4 Open	398
Barley-Feed Malting	904 to 1095 786 to 904	1/2"	1/4"	T	T	T	As Required	Adjustable	1/3 to 1/2 Open	3/4 Open	620 to 680
Beans-Edible	325 to 433	1/2" to 3/4"	1/4" to 1/2"	T	OG	OG	Not Required	Adjustable (preferred) or Rd. Hole	Slightly Over 1/2 Open	2/3 to Nearly Open	660 to 700
Beans-Soy	487 to 650	1/2"	1/4"	T	T	OG	Not Required	Adjustable or Rd. Hole	About 1/2 Open	About 2/3 Open	620 to 680
Beans-White Pea	487 to 650	1/2"	1/4"	T	T	OG	Not Required	Adjustable	1/2 Open	2/3 Open	660 to 700
Buck Wheat	650 to 786	1/2"	3/16"	T	T	OG	As Required	Adjustable	1/4 to 1/3 Open	About 2/3 Open	540 to 640
Clover-Most Varieties	904 to 1095	5/32" to 3/16"	1/16" to 1/8"	T	T	T	4 to 8	Adjustable (preferred) or Rd. Hole	Slightly Open	About 1/4 Open	398
Corn-Field Shelled*	386 to 575	1"	5/8"	Not Recommended			None	Adjustable or Rd. Hole	About 1/2 Open	About 2/3 Open	660 to 750
Cornob Mix-* Cracked Kern.	786 to 904	3/8"	1/4"	Not Recommended			5	None	None	3/4 Open	660 to 720
Cornob Mix-* Whole Kern.	467 to 786	3/8"	1/4"	Not Recommended			5	None	None	3/4 Open	660 to 750
Flax	786 to 1095	1/4"	1/8"	T	T	T	4	Adjustable or Rd. Hole	About 1/3 Open	3/4 Open	480 to 560
Grass-Most Varieties	904 to 1095	3/16" to 1/2"	1/8" to 5/8"	T	T	T	None to 8	Adjustable or Rd. Hole	1/4 to 1/3 Open	1/2 to 2/3 Open	398
Lespedeza	650 to 904	3/16"	1/8"	T	T	T	As Required	Adjustable or Rd. Hole	1/3 Open	1/2 to 2/3 Open	398
Maize	786 to 904	1/2"	3/16"	T	T	OG	Not Required	Adjustable	1/3 Open	2/3 Open	620 to 680
Oats	786 to 1095	5/16"	3/16"	T	T	OG	As Required	Adjustable	1/3 to 1/2 Open	3/4 Open	480 to 560
Peas-Field	386 to 536	5/8"	1/4"	T	OG	OG	Not Required	Adjustable (preferred) or Rd. Hole	About 1/3 Open	About 2/3 Open	660 to 700
Rice	786 to 904	5/16"	3/16"	T	T	OG	Not Required	Adjustable	1/3 Open	3/4 Open	660 to 700
Rye	904 to 1095	5/16"	1/4"	T	T	OG	As Required	Adjustable	1/3 Open	3/4 Open	620 to 660
Timothy	1095	5/32"	1/16"	T	T	T	4 to 8	Adjustable or Rd. Hole	Slightly Open	About 1/2	398
Wheat	904 to 1095	5/16"	3/16"	T	T	OG	As Required	Adjustable	1/3 to 1/2 Open	3/4 Open	660 to 700

* Remove cylinder filler plates when operating at speeds over 600 rpm

+ See Page 43 for Sprockets

PLATFORM AUGER SPEED ADJUSTMENTS

If straw is extremely heavy and standard 163 rpm auger speed will not carry it properly, increase auger speed to 179 rpm by using special 22-tooth drive sprocket.

ATTACHING CUTTING PLATFORM

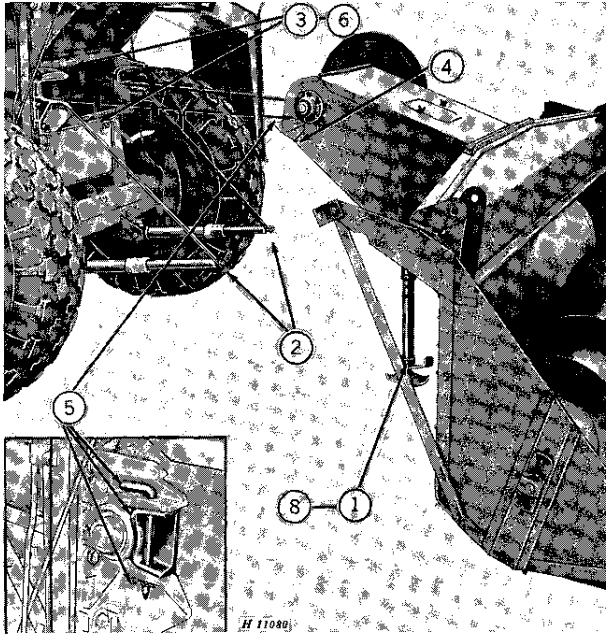

1. Block the cutting platform under hinge brackets or install support stand (special attachment).

2. Wire up hydraulic cylinders or install support chain (special attachment).

3. Remove cylinder front door and lower grain conveyor front door.

4. Raise feeder house hinged plate.

5. Drive separator forward and attach U-bracket to feeder house.

6. Install cylinder front door and raise grain conveyor front door.

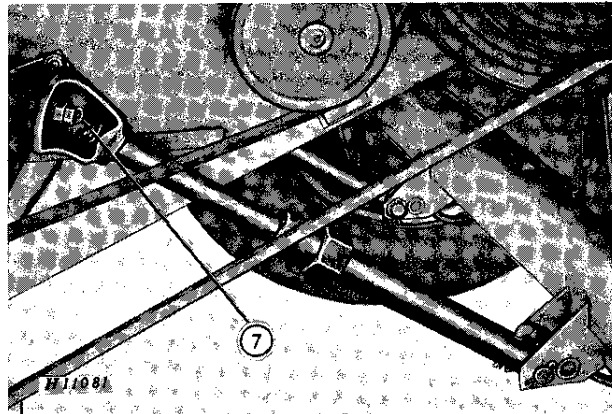

7. Attach hydraulic cylinders to hinge brackets.

8. Remove blocking or place support stand in transport position.

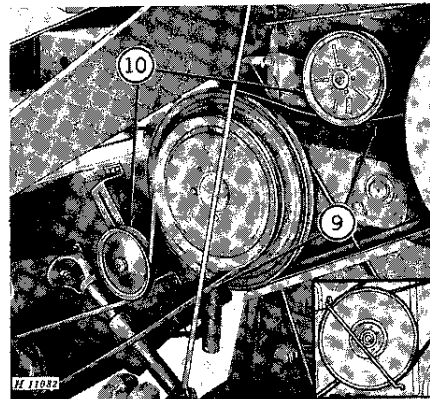

9. Install platform drive belts.

10. Adjust belt tension. (See page 41).

REMOVING CUTTING PLATFORM

To remove cutting platform, block under hinge brackets, or place support stand in upright position. Remove cylinder front door and lower the grain conveyor front door. Remove platform drive belts, pins from hydraulic cylinders, and pins and retainers from U-brackets on separator. Drive separator rearward slowly until front of separator clears rear of feeder house. Wire up hydraulic cylinders, install cylinder front door, and raise grain conveyor front door.



Suggest:

If the above button click is invalid.

Please download this document

first, and then click the above link

to download the complete manual.

Thank you so much for reading

CUTTING PLATFORM LEVELING ADJUSTMENT

To insure satisfactory performance, the cutting platform and the front axle tube must be parallel.

Inspect platform and tube periodically, using the following method:

Raise the cutting platform to maximum height.

Take a position approximately 15 feet directly in front of the cutting platform.

Compare the bottom of the cutting platform with the front axle tube to see if they are parallel.

NOTE: Main wheel tires must be inflated to equal pressure, otherwise an accurate platform leveling adjustment cannot be accomplished.

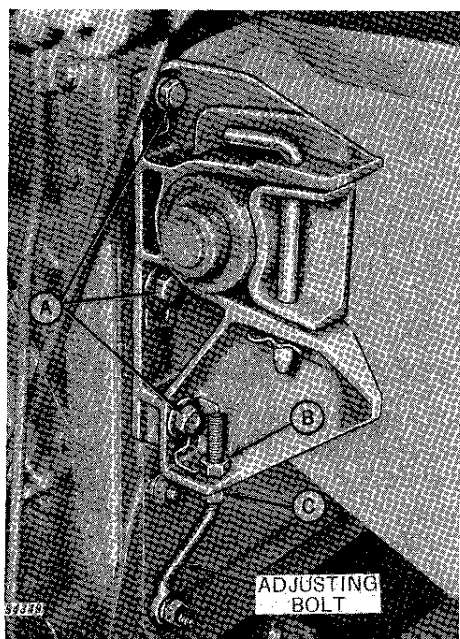

To adjust:

Loosen the three bolts "A" securing right-hand pivot bracket to separator.

Loosen lock nut "B" on adjusting bolt.

Thread adjusting nut "C" up to raise right-hand side of cutting platform or down to lower right-hand side of cutting platform.

When bottom of cutting platform is parallel with front axle tube, tighten the three bolts "A."
CAUTION: These bolts must be tight.

Tighten lock nut "B."

COLD WEATHER OPERATION

Operating a combine in cold weather requires special preparation.

HYDRAULIC UNIT AND ENGINE CRANKCASE

Use the grade of oil recommended in the lubrication chart, page 23. Lubricants of the right viscosity are necessary for proper protection.

TRANSMISSION CASE AND FINAL DRIVES

Be certain that SCL Multipurpose-type SAE 90 gear lubricant is being used.

FUEL SYSTEM

Use winter-grade fuel. Fill the fuel tank at the end of the day's run to prevent moisture from condensing in the fuel tank.

COOLING SYSTEM

To prevent freezing when temperature is 32° F. or lower, either drain the cooling system at the end of each day's run or use an antifreeze solution. The use of antifreeze is recommended. When refilling radiator with water or antifreeze add rust inhibitor.

CAUTION: Never use calcium chloride solution in the radiator. It is harmful to metal.

Add water or antifreeze slowly until the level is approximately 1 inch below the bottom of the filler neck.

Antifreeze Requirements	
Lowest Expected Temperature	Ethylene Glycol
+15°	3 Quarts
+ 6°	4 Quarts
- 5°	5 Quarts
-18°	6 Quarts
-34°	7 Quarts

<https://www.ebooklibonline.com>

Hello dear friend!

Thank you very much for reading.

Enter the link into your browser.

The full manual is available for immediate download.

<https://www.ebooklibonline.com>