

JOHN DEERE
WORLDWIDE COMMERCIAL & CONSUMER
EQUIPMENT DIVISION

Snowblower
44-Inch

OMM163342 E0

OPERATOR'S MANUAL



JOHN DEERE

Original Instruction

All information, illustrations and specifications in this manual are based on the latest information at the time of publication. The right is reserved to make changes at any time without notice.

COPYRIGHT© 2010
Deere & Co.

John Deere Worldwide Commercial and Consumer Equipment Division

All rights reserved
Previous Editions
COPYRIGHT© 2006

North American Version
Litho in U.S.A.

INTRODUCTION

Table of Contents

Introduction.....	1
Product Identification.....	1
Safety.....	2
Safety Labels.....	4
Assembly - Identify Parts.....	5
Assembly.....	9
Preparing Vehicle.....	12
Installing.....	12
Removing and Storing.....	14
Operating.....	16
Service.....	18
Troubleshooting.....	21
Specifications.....	21
Getting Quality Service.....	22

Introduction

Using Your Operator's Manual

Read this entire operator's manual, especially the safety information, before operating.

This manual is an important part of your machine. Keep all manuals in a convenient location so they can be accessed easily.

Use the safety and operating information in the attachment operator's manual, along with the machine operator's manual, to operate and service the attachment safely and correctly.

If your attachment manual has a section called Preparing the Machine, it means that you will have to do something to your tractor or vehicle before you can install the attachment. The Assembly and Installation sections of this manual provide information to assemble and install the attachment to your tractor or vehicle. Use the Service section to make any needed adjustments and routine service to your attachment.

If you have any questions or concerns with the assembly, installation, or operation of this attachment, see your local John Deere dealer or call the John Deere Customer Contact Center at 1-800-537-8233 for assistance.

Warranty information on this John Deere attachment can be found in the warranty that came with your John Deere tractor or vehicle.

Product Identification

Record Identification Numbers

Snowblower For John Deere L100 Series, G100 Series, D100 Series and 100 Series.

44-Inch Serial No. (050001 -)

When contacting a John Deere Dealer for information on servicing, always provide the product model and serial number.

Locate the model and serial number for the machine and record the information in the spaces provided below.

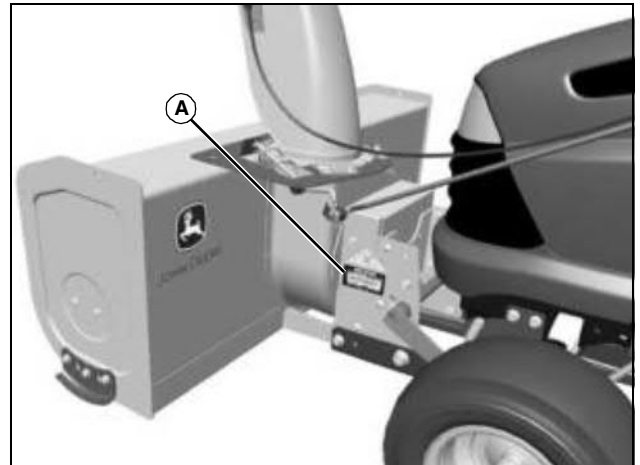

MX37425

DATE OF PURCHASE:

DEALER NAME:

DEALER PHONE:

PRODUCT SERIAL NUMBER (A):

SAFETY

Safety

Read Safety in Machine Operator's Manual

Read the general safety operating precautions in your machine operator's manual for additional safety information.

Safe Operation Practices for Ride On Snow Throwers

This snowthrower is capable of amputating hands and feet and throwing objects. Failure to observe the following safety instructions could result in serious injury.

Training

- Read, understand and follow all instructions on the machine and in the manuals before operating this unit. Be thoroughly familiar with the controls and the proper use of the equipment. Know how to stop the unit and disengage the controls quickly.
- Never allow children to operate the equipment. Never allow adults to operate the equipment without proper instruction.
- Keep the area of operation clear of all persons, particularly small children.

Preparation

- Thoroughly inspect the area where the equipment is to be used and remove all doormats, sleds, boards, wires, and other foreign objects.
- Disengage all clutches and shift into neutral before starting the engine.
- Do not operate the equipment without wearing adequate winter garments. Avoid loose fitting clothing that can get caught in moving parts. Wear footwear that will improve footing on slippery surfaces.
- Handle fuel with care; it is highly flammable.
 - a. Use an approved fuel container.
 - b. Never add fuel to a running engine or hot engine.
 - c. Fill fuel tank outdoors with extreme care. Never fill fuel tank indoors.
 - d. Never fill containers inside a vehicle or on a truck or trailer bed with a plastic liner. Always place containers on the ground, away from your vehicle, before filling.
 - e. When practical, remove gas-powered equipment from the truck or trailer and refuel it on the ground. If this is not possible, then refuel such equipment on a trailer with a portable container, rather than from a gasoline dispenser nozzle.
 - f. Keep the nozzle in contact with the rim of the fuel tank or container opening at all times, until refueling is complete. Do not use a nozzle lock-open device.
 - g. Replace gasoline cap securely and wipe up spilled fuel.
 - h. If fuel is spilled on clothing, change clothing immediately.
- Adjust the collector housing height to clear gravel or crushed rock surface.
- Never attempt to make any adjustments while the engine is running (except when specifically recommended by the manufacturer).
- Always wear safety glasses or eye shields during operation or while performing an adjustment or repair to protect eyes from foreign objects that may be thrown from the machine.

Operation

- Do not put hands or feet near or under rotating parts. Keep clear of the discharge opening at all times.
- Exercise extreme caution when operating on or crossing gravel drives, walks, or roads. Stay alert for hidden hazards or traffic.
- After striking a foreign object, stop the engine, remove the spark plug wire, thoroughly inspect the snow thrower for any damage, and repair the damage before restarting and operating the snow thrower.
- If the unit should start to vibrate abnormally, stop the engine and check immediately for the cause.
- Stop the engine whenever you leave the operating position, before unclogging the collector or impeller housing, or discharge guide, and when making any repairs, adjustments or inspections.
- When leaving the machine unattended, disengage the power take-off, lower the attachment, lock the park brake, stop the engine, and remove the key.
- When cleaning, repairing, or inspecting, make certain the collector or impeller and all moving parts have stopped. Disconnect the spark plug wire and keep the wire away from the plug to prevent accidental starting.
- Do not run the engine indoors, except when starting the engine and for transporting the snow thrower in or out of the building. Open the outside doors; exhaust fumes are dangerous.
- Do not clear snow across the face of slopes, go up and down. Exercise extreme caution when operating on slopes. Do not attempt to clear steep slopes.
- Never operate the snow thrower without proper guards, and other safety protective devices in place.
- Never direct the discharge toward people or areas where property damage can occur. Keep children and others away.
- Do not overload the machine capacity by attempting to clear snow at too fast a rate.
- Never operate the machine at high transport speeds on slippery surfaces. Look behind and use care when backing.
- Do not carry passengers.
- Never direct discharge at bystanders or allow anyone in front of the unit.
- Disengage power to the collector or impeller when the snow thrower is transported or not in use.
- Use only attachments and accessories approved by the manufacturer of the snow thrower (such as wheel weights, counterweights, and cabs).
- Never operate the snow thrower without good visibility or light.

Parking Safely

1. Stop machine on a level surface, not on a slope.
2. Disengage mower blades or any other attachments.
3. Lower attachments to the ground.
4. Lock the park brake.
5. Stop the engine.
6. Remove the key.
7. Wait for engine and all moving parts to stop before you leave the operator's seat.
8. Close fuel shut-off valve, if your machine is equipped.
9. Disconnect the negative battery cable or remove the spark plug wire(s) (for gasoline engines) before servicing the machine.

Clearing a Clogged Discharge Chute

<https://www.ebooklibonline.com>

Hello dear friend!

Thank you very much for reading.

Enter the link into your browser.

The full manual is available for immediate download.

<https://www.ebooklibonline.com>

SAFETY

- Hand contact with the rotating impeller inside the discharge chute is the most common cause of injury associated with snowthrowers. Never use your hand to clean out the discharge chute.
- To clear the chute:
 - a. Shut the engine off.
 - b. Wait ten seconds to be sure the impeller blades have stopped rotating.
 - c. always use a clean-out tool, not your hands.

Maintenance and Storage

- Check shear bolts and other bolts at frequent intervals for proper tightness to be sure the equipment is in safe working condition.
- Never store the machine with fuel in the fuel tank inside a building where ignition sources are present such as hot water and space heaters, and clothes dryers. Allow the engine to cool before storing in any enclosure.
- Always refer to operator's manual for important details if the snow thrower is to be stored for an extended period.
- Maintain or replace safety and instruction labels as necessary.
- Run the machine a few minutes after throwing snow to prevent freeze up of the collector or impeller.

Practice Safe Maintenance

- Only qualified, trained adults should service this machine.
- Understand service procedure before doing work. Keep area clean and dry.
- Do not operate the engine in a confined space where dangerous carbon monoxide fumes can collect.
- Never lubricate, service or adjust the machine or attachment while it is moving. Keep safety devices in place and in working condition. Keep hardware tight.
- Keep hands, feet, clothing, jewelry, and long hair away from any moving parts, to prevent them from getting caught.
- Lower any attachment completely to the ground or to an existing attachment mechanical stop before servicing the attachment. Disengage all power and stop the engine. Lock park brake and remove the key. Let machine cool.
- Disconnect battery or remove spark plug wire (for gasoline engines) before making any repairs.
- Before servicing machine or attachment, carefully release pressure from any components with stored energy, such as hydraulic components and springs.
- Release hydraulic pressure by lowering attachment or cutting units to the ground or to a mechanical stop and move hydraulic control levers.
- Securely support any machine or attachment elements that must be raised for service work. Use jack stands or lock service latches to support components when needed.
- Never run engine unless park brake is locked.
- Keep all parts in good condition and properly installed. Fix damage immediately. Replace worn or broken parts. Replace all worn or damaged safety and instruction decals.
- Check all hardware at frequent intervals to be sure the equipment is in safe working condition.
- Do not modify machine or safety devices. Unauthorized modifications to the machine or attachment may impair its function and safety.

Avoid Injury from Moving Parts

Before cleaning, repairing, or inspecting, make certain all moving parts have stopped. Disconnect the tractor spark plug wire or battery to prevent accidental starting.

Do not put hands or feet near or under rotating parts. Keep clear of any discharge area at all times.

Protect your hands when you inspect or unplug the attachment. Wear gloves and use proper tools.

Before you dismount to unplug or adjust attachment:

- Disengage PTO.
- Stop the engine.
- Lock the park brake.
- Remove the key.
- Wait for all moving parts to stop.
- Keep hands, feet and clothing away from attachment when engine is running.

Avoid Injury from Hitting Obstructions

- Raise the attachment when driving between jobs.
- Drive at slow speeds when using the attachment. Be cautious of hidden obstacles.

SAFETY LABELS

DANGER M154693

Safety Labels



Understanding The Machine Safety Labels

The machine safety labels shown in this section are placed in important areas on your machine to draw attention to potential safety hazards.

On your machine safety labels, the words DANGER, WARNING, and CAUTION are used with this safety-alert symbol. DANGER identifies the most serious hazards.

The operator's manual also explains any potential safety hazards whenever necessary in special safety messages that are identified with the word, CAUTION, and the safety-alert symbol.

There can be additional safety information contained on parts and components sourced from suppliers that is not reproduced in this operator's manual.



M154693

WARNING and CAUTION M144854



M144854

ROTATING BLADE

- Shut off engine before unclogging discharge chute.

TO AVOID INJURY FROM THROWN OBJECTS

- Read operator's manual.
- Keep all shields in place.
- Keep bystanders a safe distance away.

To avoid injury from loss of braking or steering,

- Install ballast per operator's manual.

DANGER M144853



M144853

To avoid injury from rotating auger, keep hands, feet and clothing away.

ASSEMBLY - IDENTIFY PARTS

Snowblower Parts

Assembly - Identify Parts

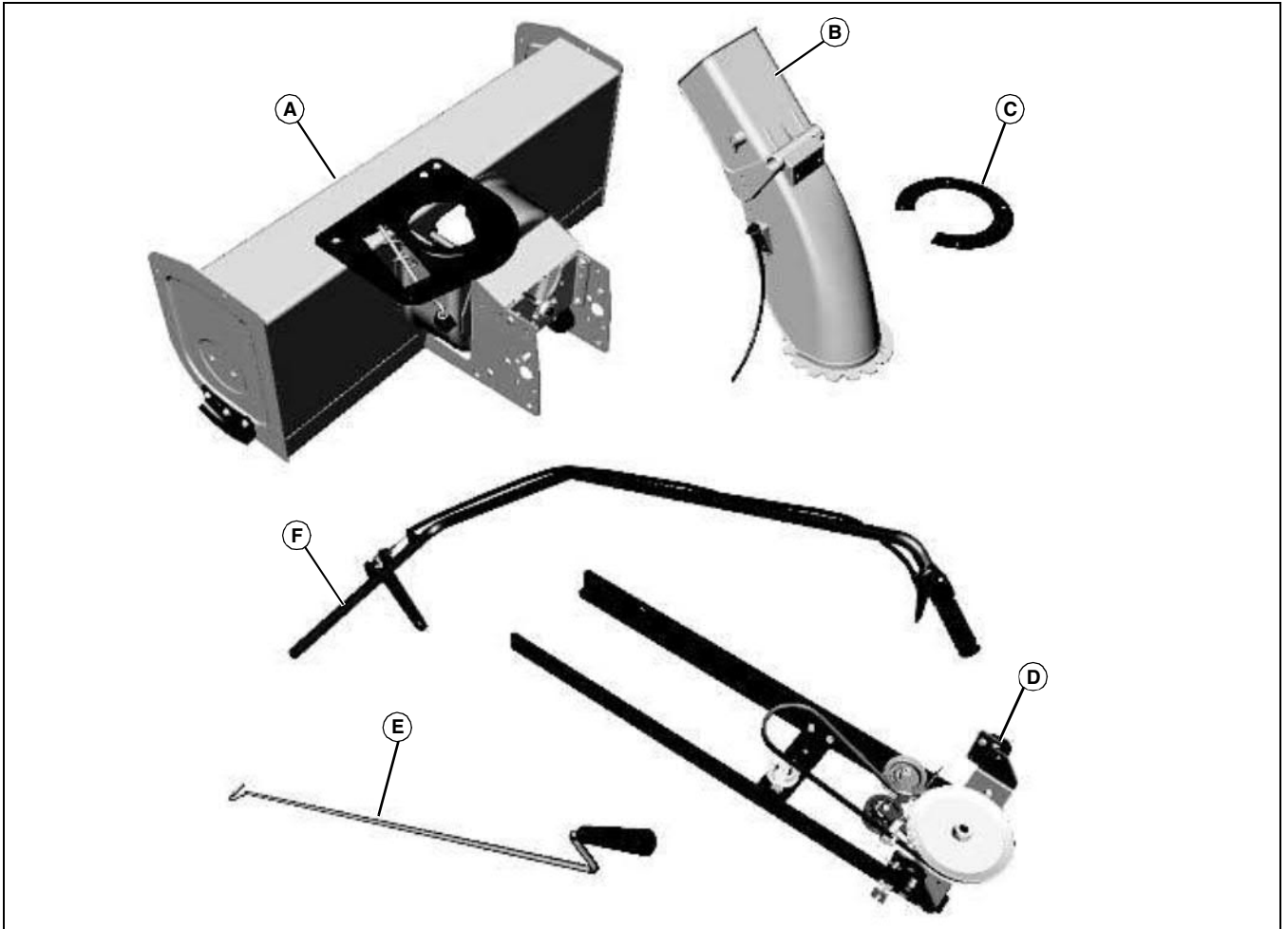

MX37506a

Key	Description	Qty	Key	Description	Qty
A	Housing	1	D	Frame	1
B	Chute Assembly	1	E	Chute Control Handle	1
C	Chute Retaining Bracket	1	F	Lift Lever Assembly	1

ASSEMBLY - IDENTIFY PARTS

Frame Parts

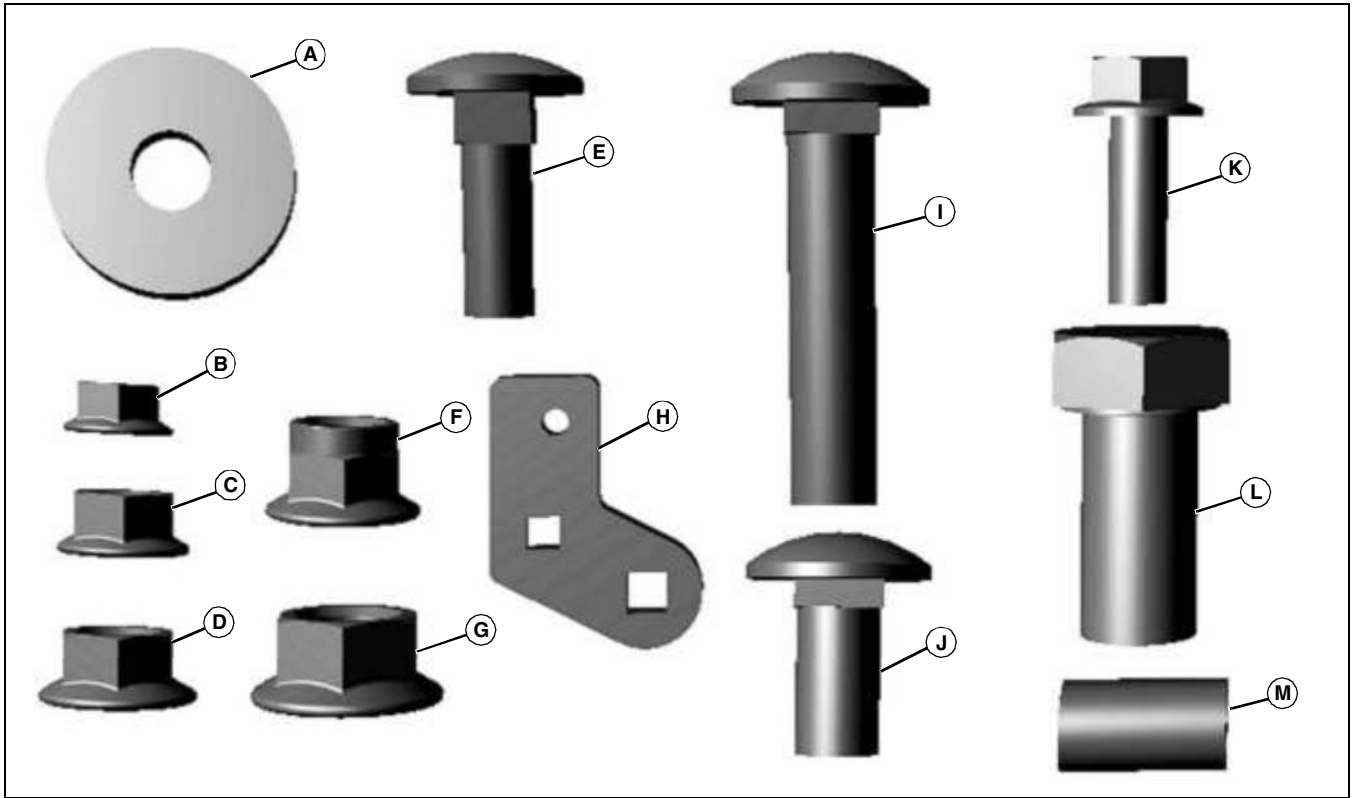

MX38108a

Picture Note: Hardware shown actual size unless noted.

Key	Description	Qty	Key	Description	Qty
A	Washer, M11x34 OD	2	H	Rear Mounting Plate (Not shown actual size)	2
B	Nut, Flange, M8	2	I	Carriage Bolt, M12x55	2
C	Nut, Flange, M10	2	J	Carriage Bolt, M12x25	2
D	Nut, Flange, M12	2	K	Bolt, Flange, M8x25	2
E	Carriage Bolt, M10x30	2	L	Bolt, Hex Head, M16x30	2
F	Locknut, Flange, M12	2	M	Bushing, M12x30 (Not shown actual size)	2
G	Nut, Flange, M16	2			



Suggest:

If the above button click is invalid.

Please download this document

first, and then click the above link

to download the complete manual.

Thank you so much for reading

ASSEMBLY - IDENTIFY PARTS

Lift Parts

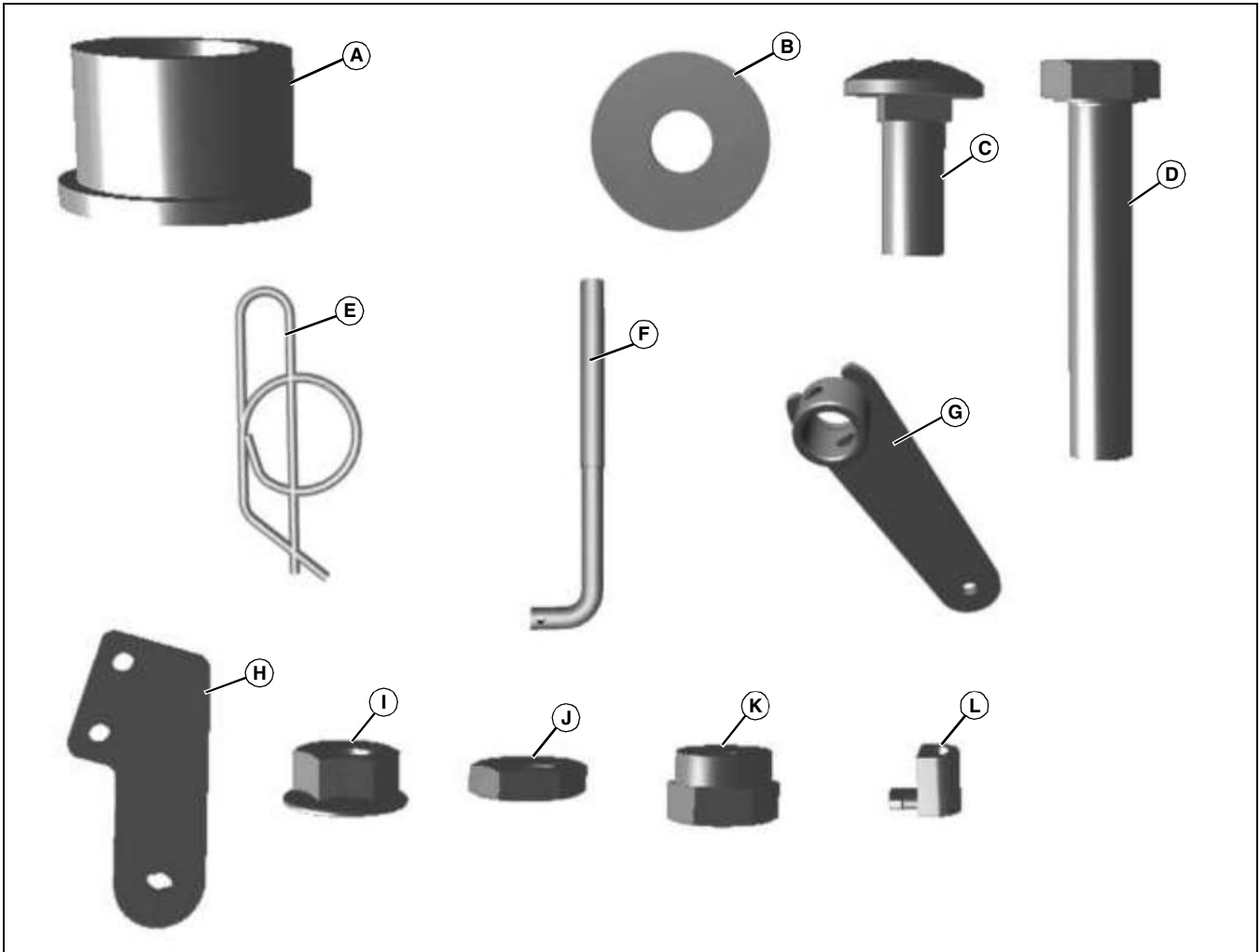

MX46151

Picture Note: Hardware shown actual size unless noted.

Key	Description	Qty	Key	Description	Qty
A	Bearing, 25 mm ID	2	G	Lift Arm (Not actual size)	1
B	Washer, M10x30 OD	2	H	Front Mounting Plate (Not actual size)	2
C	Carriage Bolt, M10x25	4	I	Nut, Flange, M10	4
D	Bolt, M10x55	1	J	Nut, M10	2
E	Cotter Pin, Locking (Not actual size)	2	K	Locknut, M10	3
F	Adjustable Lift Rod (Not actual size)	2	L	Adjustable Lift Link (Not actual size)	2

<https://www.ebooklibonline.com>

Hello dear friend!

Thank you very much for reading.

Enter the link into your browser.

The full manual is available for immediate download.

<https://www.ebooklibonline.com>