

40 SERIES CORN HEADS



JOHN DEERE

OPERATORS MANUAL 40 SERIES CORN HEADS

OMH116949 I3 English

OMH116949 I3

LITHO IN THE U.S.A.
ENGLISH



INTRODUCTION

 This safety alert symbol identifies important safety messages in this manual. When you see this symbol, be alert to the possibility of personal injury and carefully read the message that follows.

NOTE: If this corn head is attached to any combine, other than a John Deere, be certain all exposed drives are adequately shielded.

Your operator's manual contains SI Metric equivalents which follow immediately after the U.S. customary units of measure.

"Right-hand" and "left-hand" sides are determined by facing in the direction the corn head will travel.

Record your corn head serial number in the space provided on SPECIFICATIONS.

The warranty on this corn head appears on your copy of the purchase order which you should have received from your dealer when making your purchase. This warranty provides you the assurance that John Deere will back its products where defects appear within the warranty period. In some circumstances, John Deere also provides field improvements, often without charge to the customer, even if the product is out of warranty.

Warranty and field improvements are a part of John Deere's product support program for customers who operate and maintain their equipment as described in this manual. Should the equipment be abused, or modified to change its performance beyond the original factory specifications, the warranty will become void and field improvements may be denied.

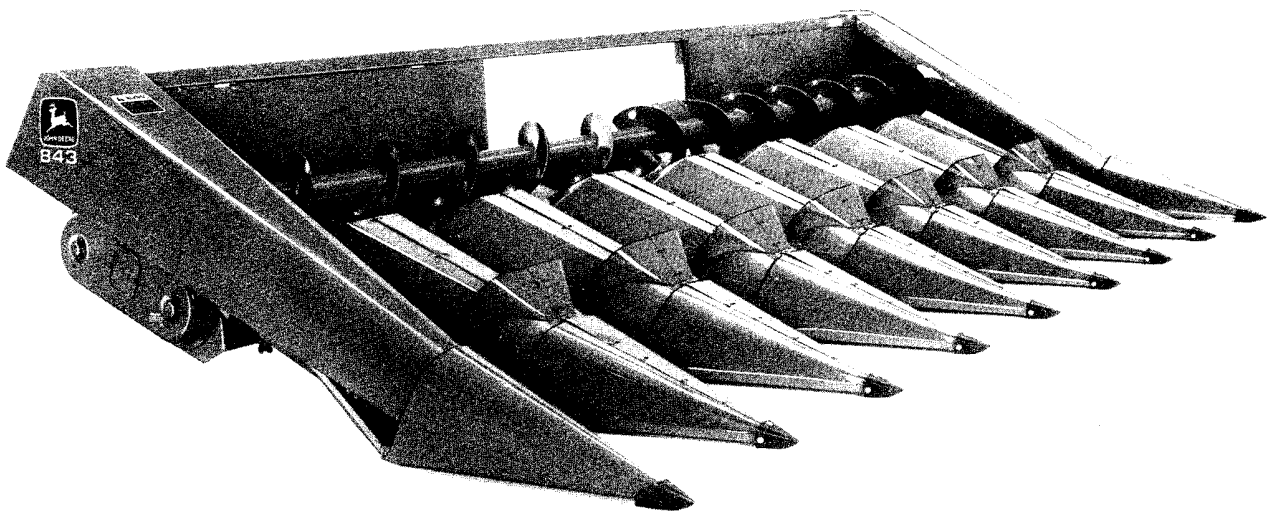



Contents

	Page
Contents	1
Safety	2
Preparing the Combine	5
Preparing the Corn Head	12
Attaching and Detaching	14
Transporting	24
Operating the Corn Head	25
Lubricants	49
Lubrication and Maintenance	50
Trouble Shooting	55
Service	59
Storage	62
Specifications	63
Index	65

<https://www.ebooklibonline.com>

Hello dear friend!

Thank you very much for reading.

Enter the link into your browser.

The full manual is available for immediate download.

<https://www.ebooklibonline.com>



Safety

Unauthorized modifications to the machine may impair the function and/or safety and affect machine life.

NOTE: If this corn head is attached to any combine, other than a John Deere, be certain all exposed drives are adequately shielded.

SAFETY DECALS



H78488N



CAUTION, WARNING OR DANGER: Decals with these headings and symbol indicate the possibility of personal injury.

IMPORTANT: Decals with this heading indicate the possibility of damage to the machine.

Decals are located in areas where they apply.

AVOID CONTACT WITH MOVING PARTS

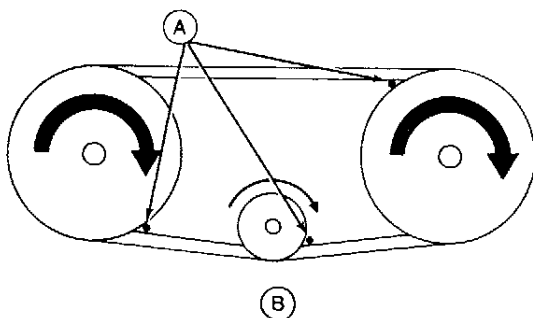

H31200

H31200

Keep hands, feet, and clothing away from power-driven parts.

Never clean, lubricate, or adjust the corn head when it is running.

Never attempt to clear obstructions off the corn head unless the combine engine is shut off.

A—Pinch Points
B—Belt Drive

TRANSPORTING

Check local width laws before transporting. It is recommended that you use a Model 25 Transport Frame for the 1243 and other 40 Series Headers.

LEAVING COMBINE UNATTENDED

Before leaving the combine unattended, turn off engine and remove keys. Support the corn head with the hydraulic cylinder safety stop, or lower it to the ground. Place the gearshift lever in neutral and engage the parking brake. Lock cab doors on 6620, SideHill 6620, 7720, and 8820 Combines.

OPERATE SAFELY

Clothing worn by operator must be fairly tight and belted. Loose jackets, shirts, or sleeves must never be worn.

Any time work is being done under corn head, the hydraulic cylinder safety stops must be placed in the safety position.

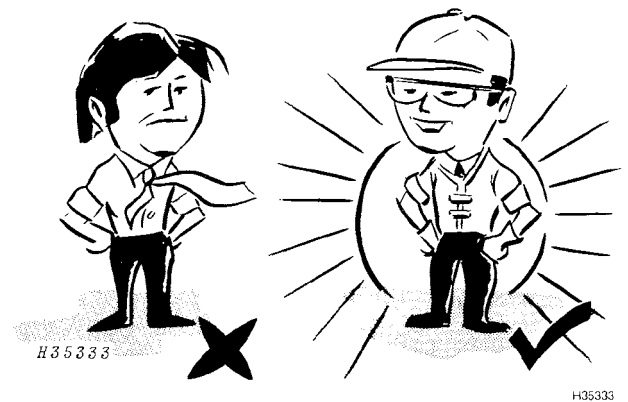

AVOID HIGH-PRESSURE FLUIDS

Escaping fluid under pressure can penetrate the skin, causing serious injury. Relieve pressure before disconnecting hydraulic or other lines. Tighten all connections before applying pressure. Keep hands and body away from pinholes and nozzles which eject fluids under high pressure. Use a piece of cardboard or paper to search for leaks. Do not use your hand.

If ANY fluid is injected into the skin, it must be surgically removed within a few hours by a doctor familiar with this type injury or gangrene may result.

Cracking hydraulic line fittings to lower feeder house will result in an instantaneous dropping of feeder house or feeder house and header.

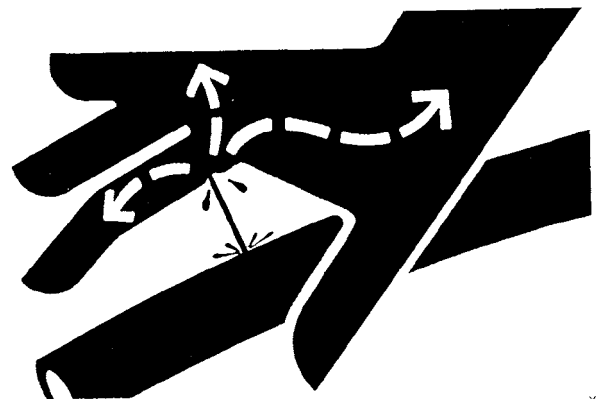

X9811

PROTECT AGAINST NOISE



Prolonged exposure to loud noise can cause impairment or loss of hearing.

Wear a suitable hearing protective device such as earmuffs (A) or earplugs (B) to protect against objectionable or uncomfortable loud noises.

A—Earmuffs
B—Earplugs

1243 CORN HEAD TIRE REQUIREMENTS

IMPORTANT
30.5L-32 16PR R1 or
73 x 44.00-32 12PR HF
tires are required on
8820 combine when
operating this header.

H37375

Either 30.5 L 16 PR or 73 x 44.00-32 high-flotation tires are required on 8820 Combine when operating with 1243 Header.

KEEP HANDS AWAY FROM STALK ROLLS

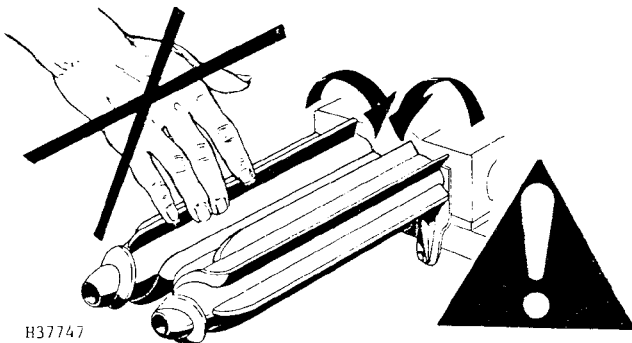

H37747

Never attempt to clear obstructions on the corn head unless the main drive is disengaged, the engine shut off and key removed.



CAUTION: Everyone must be clear before starting engine or running corn head.



Preparing The Combine

NOTE: If the combine has been used for small grain, the following changes must be made to the combine before attaching the corn head.

FEEDER HOUSE

IMPORTANT: When hoses are disconnected from the oil lines to the reel drive motor, connect the combine pressure hose to the return hose as shown (A). If connection is not made, hydraulic system can be damaged as constant operation of relief valve will cause overheating.

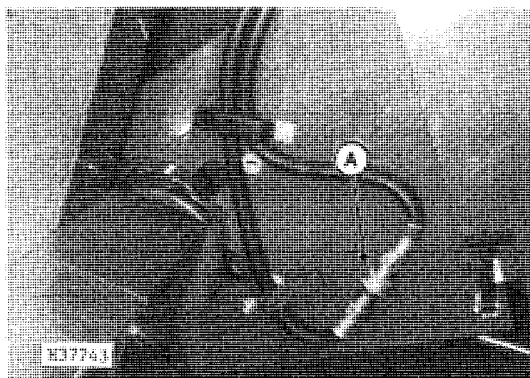

H37743



CAUTION: Escaping fluid under pressure can penetrate the skin, causing serious injury. Relieve pressure before disconnecting hydraulic or other lines. Tighten all connections before applying pressure. Keep hands and body away from pinholes and nozzles which eject fluids under high pressure. Use a piece of cardboard or paper to search for leaks. Do not use your hand.

If ANY fluid is injected into the skin, it must be surgically removed within a few hours by a doctor familiar with this type injury or gangrene may result.

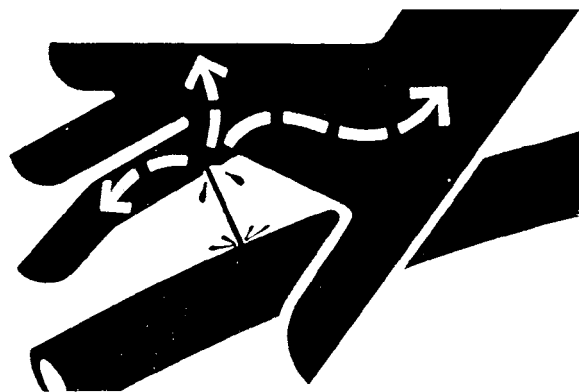

X9811

6 Preparing the Combine

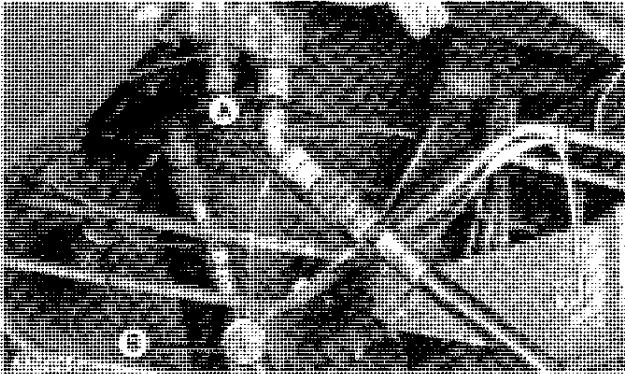

Connecting and Disconnecting Hoses - 3300, 4400, 4420, 6600, SideHill 6600, SideHill 6620, and 7700 Combines

Before attaching the corn head connect both hoses at quick-disconnect couplers (A) under operator's platform.

Start combine engine and move the variable speed feeder house control lever to close the top variable sheaves.

- A—Quick Disconnect Couplers
- B—Protective Caps

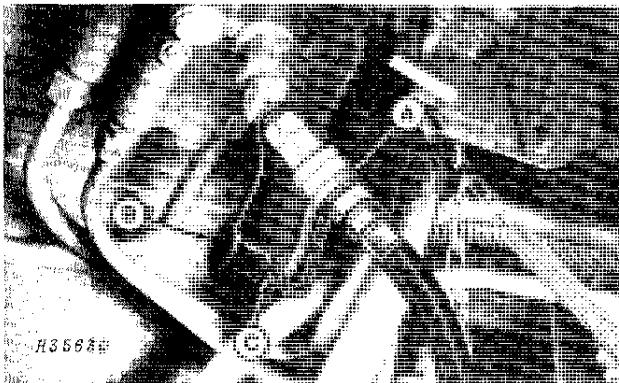

Connecting and Disconnecting Hoses - 6620, 7720, and 8820 Combines

When the hydraulic hose is connected to control valve, snap cap (C) and plug (B) together.

Whenever the hydraulic hose is disconnected from control valve, insert plug (B) into coupler (A) and snap cap (C) over coupler nose.

- A—Quick Disconnect Couplers
- B—Plug
- C—Cap

6620 - 7720 - 8820 (-600000)

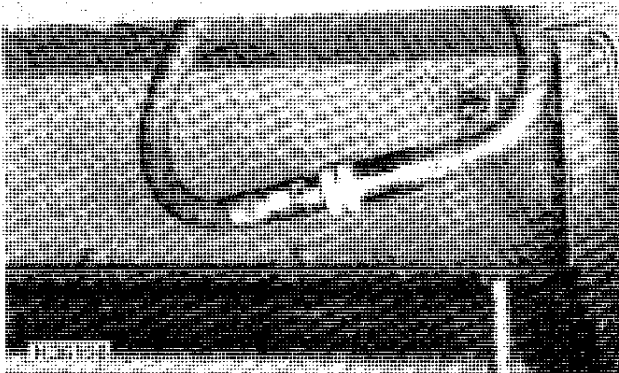

Connecting and Disconnecting Hoses - 7701 and 7721 Combines

IMPORTANT: When running the combine without the belt pickup, connect pressure line to the return line at the front of the combine to insure a free flow of hydraulic fluid to the reservoir.

7721 Combine (-600000)

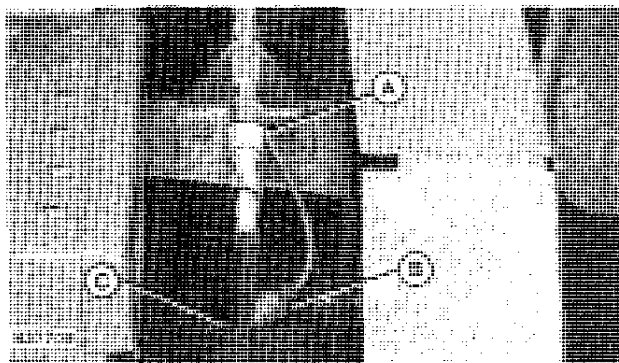

- A—Quick Disconnect Couplers
- B—Protective Cap
- C—Plug

6620, 7720, 8820 Combines (600001-)

Adjusting Feeder Conveyor "Float"

Adjust conveyor float so a 1-inch (25 mm) space exists between conveyor chain slats and the feeder house bottom.

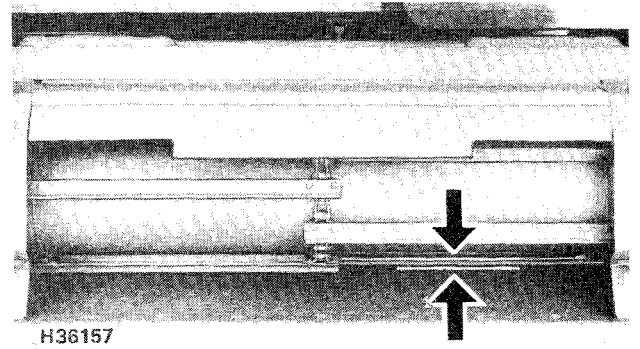

6620 Combine Illustrated

1. To obtain the 1-inch (25 mm) space, loosen nut (A).
2. Rotate bolt until hole (B) is aligned in the upper end of slot.
3. Tighten nut (A).

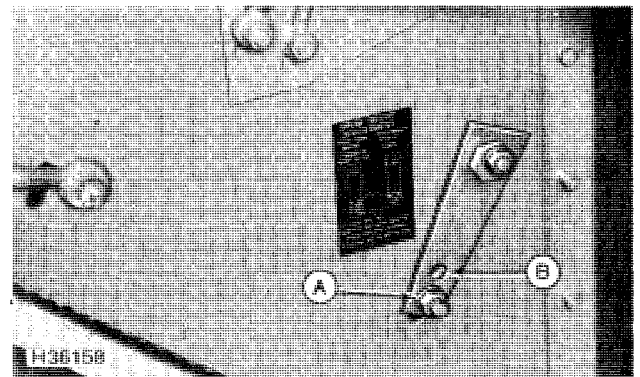

A—Nut
B—Hole

6620 Combine Illustrated

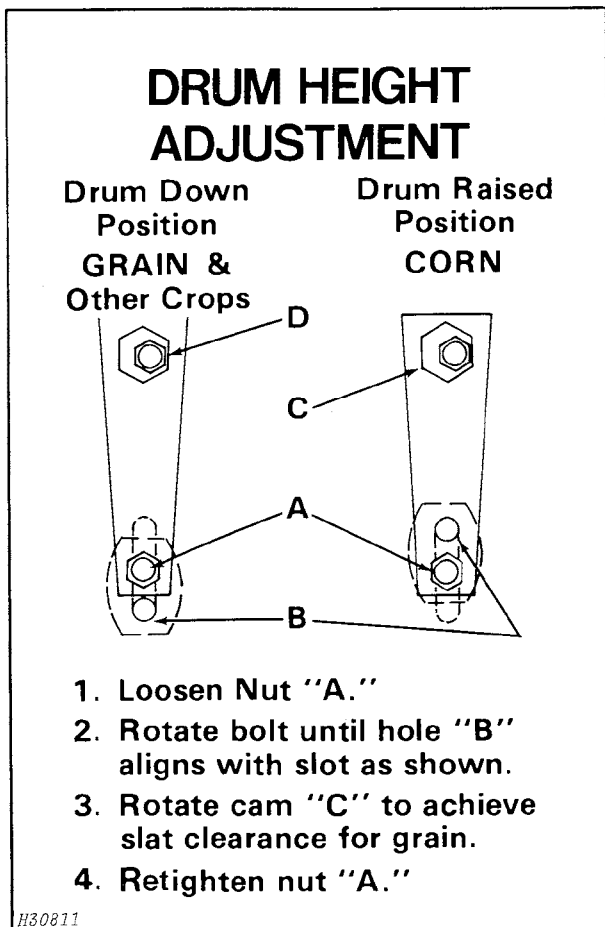

Drum Height Adjustment Decal

This decal appears on the lower right-hand side of the feeder house. Read it to obtain the proper drum height.

Adjusting Feeder Conveyor Drive Chain on Variable Speed Feeder House (All Combines Except SideHill 6600 and SideHill 6620 (-358900)

When combining corn, install drive chain on small sprocket (A).

NOTE: Large sprocket (B) is used for grain.

1. Move double sprocket to align the proper sprocket with the chain guides (C).

NOTE: It may be necessary to add or remove links from the chain when changing sprockets.

2. Loosen nut (D) and push sprocket upward until the chain will operate without climbing or jumping sprockets.
3. Adjust chain guides so they are directly under the chain with a slight clearance between the chain and ends of guides.

IMPORTANT: Do not use guides as tighteners.

- A—Small Sprocket
- B—Large Sprocket
- C—Chain Guides
- D—Nut

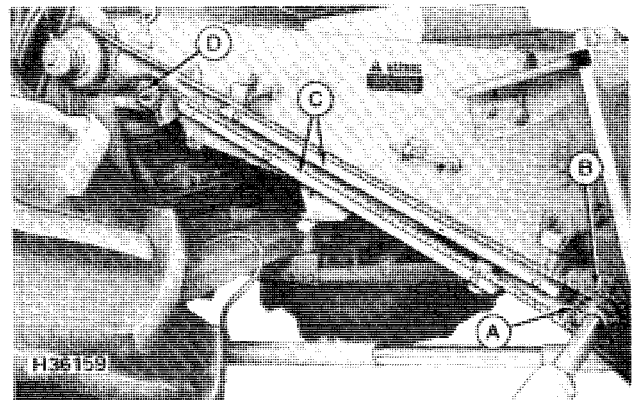

Adjusting Feeder Conveyor Drive Chain on SideHill 6620 (403301-)

When combining corn, install drive chain on large sprocket (A).

NOTE: Small sprocket (B) is used for grain.

1. Remove brace (C) and four cap screws (D) to install proper sprocket for the crop being harvested.
2. Secure proper sprocket in place with four cap screws and secure brace.

NOTE: It may be necessary to add or remove links from the chain when changing sprockets.

3. Loosen nut (E) and push sprocket down until the chain will operate without climbing or jumping sprocket.

- A—Large Sprocket
- B—Small Sprocket
- C—Brace
- D—Cap Screws
- E—Nut

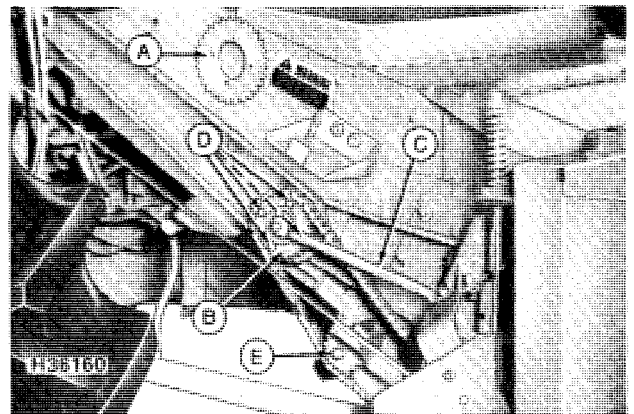

SEPARATOR

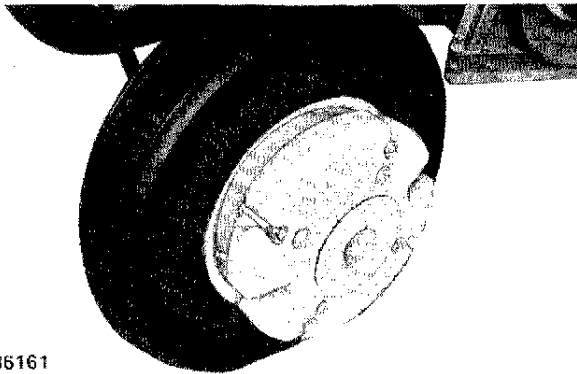

H36161

H36161

Steering Wheel Weights

Rear steering wheel weights are required for stability when using the corn head on the combine.

See your John Deere dealer.

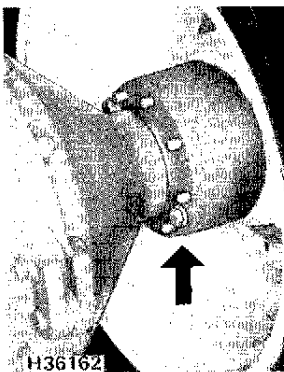

H36162

H36162

Drive Wheel Hub Spacers

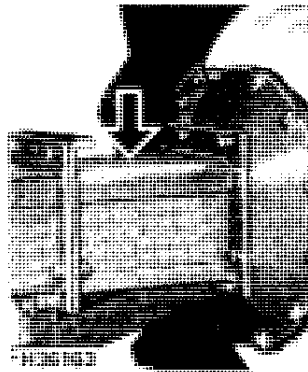

H36163

Axle Spacers

Front Wheel Spacing

Spacers are available to space wheels accurately between planted rows.

Position the front combine drive wheels to provide the wheel tread best suited to the row spacing of the corn to be harvested.

See your combine operator's manual for complete information on wheel spacing.

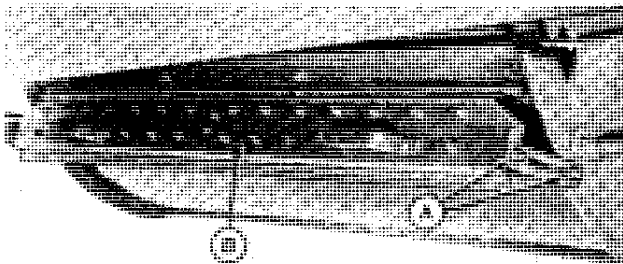

H36164

H36164

Straw Chopper (Attachment)

Loosen bolts (A) on both sides and swing knife bar (B) out. Tighten bolts (A).

IMPORTANT: Knives must be in the "out" (minimum cutting) position for operation in corn.

A—Adjusting Bolts

B—Knife Bar

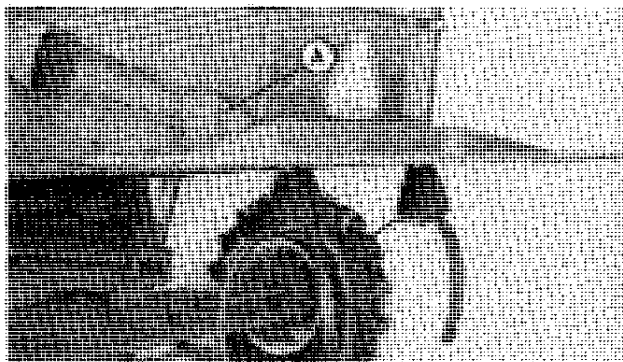

H50294

Straw Spreader (Attachment)

The drive belt must be tight enough to run without slipping.

To tighten belt, loosen cap screw (A) in slot and push up. Tighten cap screw (A).

Sieve Types

Regular tooth is used for small grains such as wheat. Deep tooth has larger openings between teeth than the regular tooth for use in corn and soybeans.

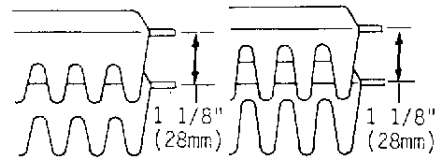

Regular Tooth

Deep Tooth

H3/167

Chaffer for Corn

The 1-5/8-inch (41 mm) adjustable, deep tooth, wide spaced chaffer is recommended for corn. The 1-1/4-inch (32 mm) throat openings between fingers and the 1-5/8-inch (41 mm) spacing of the vanes provide the most capacity available.

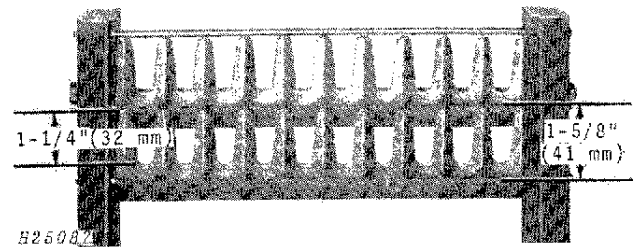

H25087

H-25087

Cylinder Filler Plates

When operating the combine in corn, install filler plates between the rasp bars. These plates increase efficiency by keeping ears from feeding between the rasp bars without being shelled. In rocky fields, they also help deflect stones into the stone trap.

The filler plates do not have to be removed when harvesting grain.

Torque filler plate cap screws to 35 lb-ft (45 N·m).

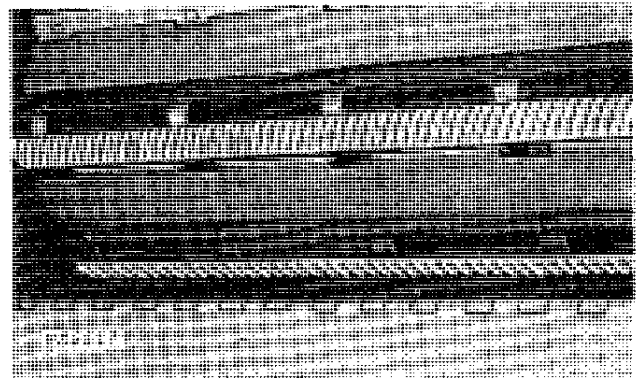

H3557

Perforated Parts (Attachment)

Perforated parts are available from your John Deere dealer, to help remove dirt and weed seed from the shelled corn.

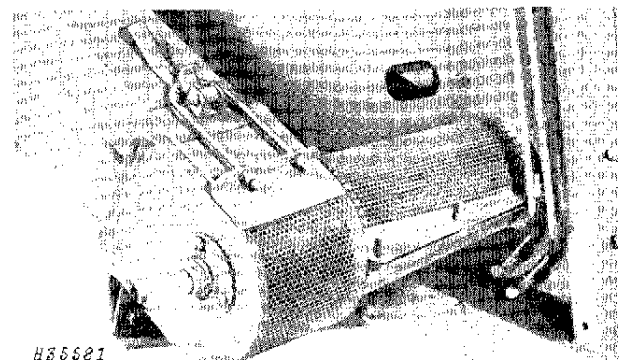

H35521

H-35521



Preparing The Corn Head

TWO- AND THREE-ROW CORN HEADS ONLY

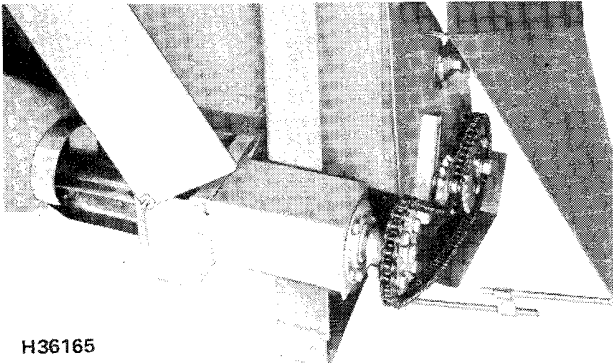

H36165

244 Corn Head Illustrated

NOTE: For mounting of a corn head on a forage harvester or a corn husker see the operator's manual for forage harvesters or corn huskers.

Before mounting the 243, 244 or 343 Corn Head on the combine, adjust the wheel shields far enough outward so the combine drive wheels do not strike them when the combine is driven forward.

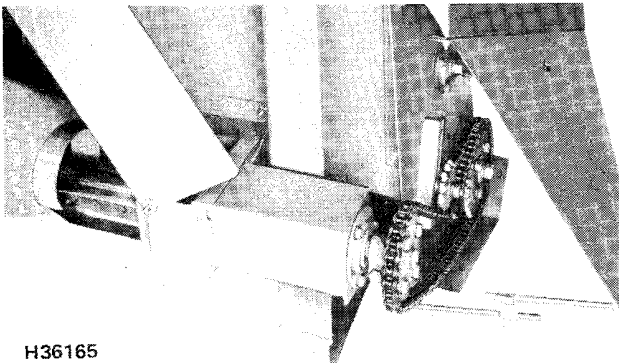

H36165

244 Corn Head Illustrated

244 and 343 Corn Head Drive Parts

The drive parts for the 244 and 343 must be mounted on the back side of the feeder house and removed when a different corn head or header is used.

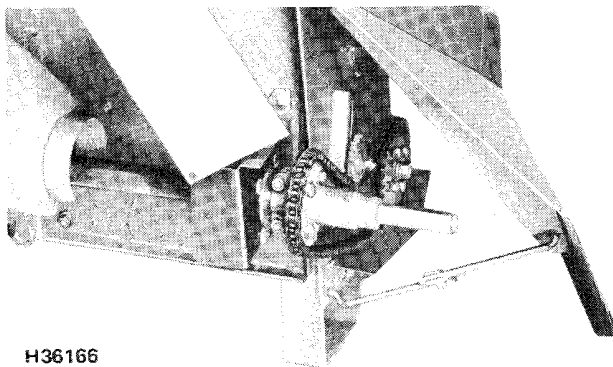

H36166

343 Corn Head Illustrated

Installing Sprockets and Drive Chain on Combines For 244 and 343 Corn Heads

Loosen tightener (A) and slip the 24-tooth drive sprocket (B) and hub on feeder house drive shaft. Align 30-tooth drive sprocket (C) with driven sprocket and tighten hub clamp bolt.

Install chain (D) on sprockets and adjust chain tension with tightener (A). Lower drive shield (E).

- A—Tightener
- B—24-Tooth Sprocket
- C—30-Tooth Sprocket
- D—Chain
- E—Drive Shield

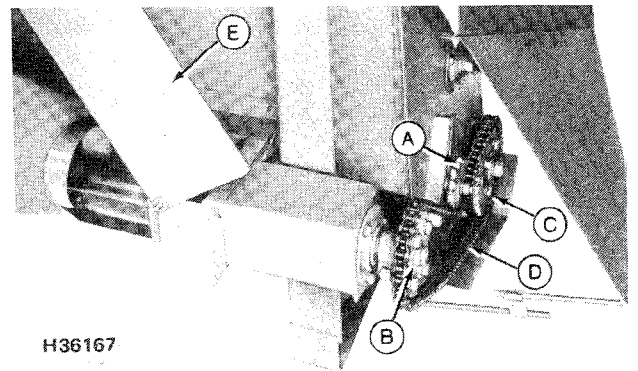

FOUR-, FIVE-, SIX-, EIGHT-, AND TWELVE-ROW CORN HEADS

On 443, 444, 546, 643, 644, 645, 843 and 1243 Corn Heads, remove and discard bolt (A) from the cover and transverse shields on both sides of the corn head. Position shields (B) up as shown. This will prevent damage to the shields when the combine is driven forward.

- A—Bolt
- B—Shield

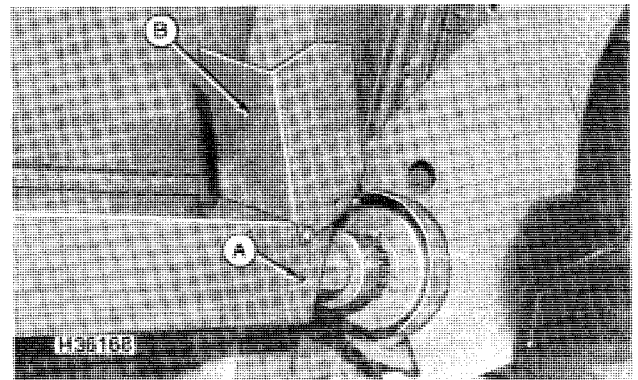



Attaching and Detaching

ATTACHING CORN HEAD TO 3300, 4400 (-350000), 6600, 7700 AND 7701 COMBINES

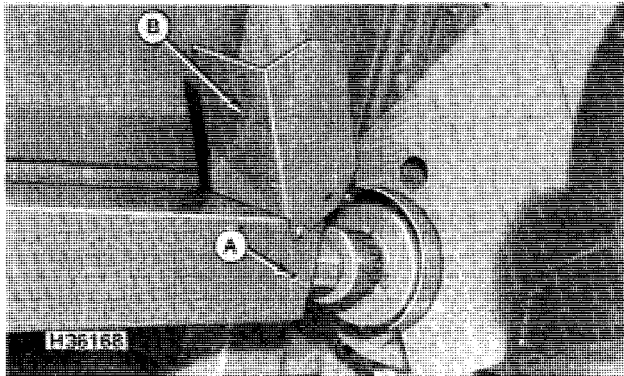

H36168

1. On all corn heads but two and three row models, remove and discard bolt (A) from shield (B) on both sides. Swing shield up to prevent damage when attaching corn head.

A—Bolt
B—Shield

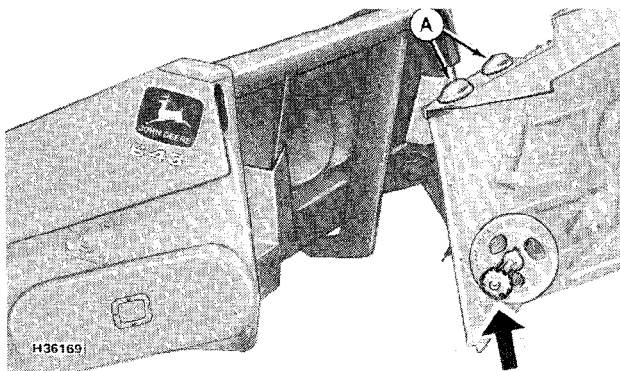

H36169

NOTE: The 344, 443 and 444 Corn Head requires one driven coupler. The 546, 643, 644, 645, and 843 Corn Heads require two drive couplers, use couplers shipped with feeder house.

2. Install coupler on lower feeder house shaft.
3. Start engine and lower feeder house.
4. Move combine slowly forward until feeder house is centered in corn head opening. Raise feeder house, lifting corn head all the way up. Shut off engine.

IMPORTANT: Pivot blocks (A) on feeder house must be properly seated in pocket under top beam of header.

A—Pivot Blocks

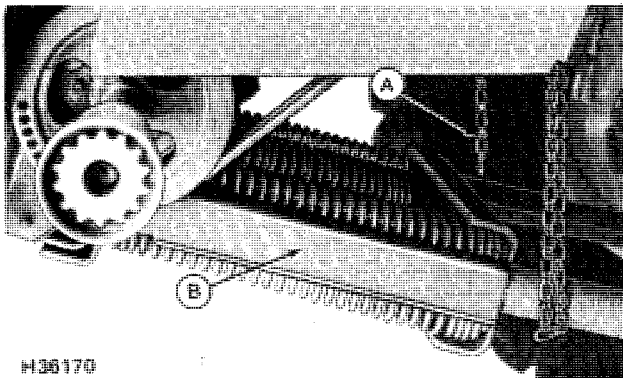

H36170

H36170

5. Disconnect chain (A) and lower hydraulic cylinder safety stop (B) on lift cylinder.

A—Support Chain
B—Safety Stop

6. Secure corn head to feeder house with three 1/2 x 1-1/2-inch round head bolts and 17/32 x 1-1/4 x .180-inch flat washers in bottom holes.
7. Place roller chain around sprockets, slide coupler over sprockets and chain. Position shield over coupler. Repeat procedure on other side.

**DETACHING CORN HEAD FROM 3300, 4400 (-350000),
6600, 7700 AND 7701 COMBINES**

1. Start engine and raise corn head all the way up. Shut off engine.
2. Disconnect chain and lower hydraulic cylinder safety stop on lift cylinder.
3. Swing shield up, slide coupler off sprockets and chain, and remove coupler chain. Repeat procedure on other side.
4. Remove three 1/2 x 1-1/2-inch round head bolts and 17/32 x 1-1/4 x .180-inch flat washers.
5. Raise hydraulic cylinder safety stop and hook chain.
6. Start engine and lower feeder house until corn head is on the ground and attaching blocks are free.
7. Move combine slowly rearward until feeder house is clear of corn head.



Suggest:

If the above button click is invalid.

Please download this document

first, and then click the above link

to download the complete manual.

Thank you so much for reading

ATTACHING CORN HEAD TO 4400 (350001-), 4420, 6620, 7720, 7721 AND 8820 COMBINES

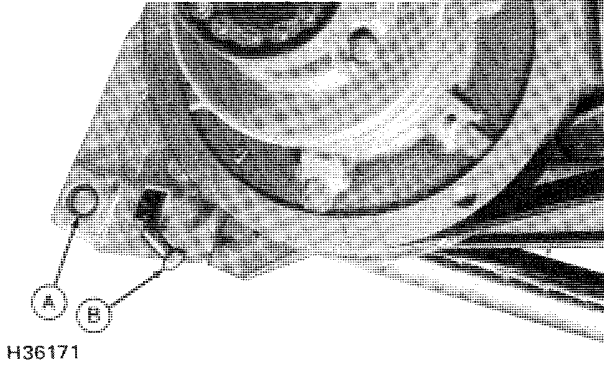

IMPORTANT: Lock pin (A) (both sides) must be positioned in before attaching header. Position pin by sliding stop bolt (B) in and then pivoting it down. If pins are left in the out position, the feeder house will be damaged when mounting a header.

A—Lock Pin
B—Stop Bolt

<u>Model</u>	<u>Driven</u>	<u>No. of Couplers</u>	<u>Type</u>	<u>Shipped</u>
443 and 444	Right-hand Side	One	Clamp	Right-hand Corn head Drive Shaft
546, 643 644, 645 and 843	Both Sides	Two	Clamp	Right and left-hand drive shafts of corn head
844 and 1243	Both Sides	Two	Clamp Quik	Right-hand corn head Drive Shaft Left-hand corn head drive shaft Loose in Grain Tank of 8820

Before attaching the corn head to the combine, read the chart and check the illustrations to determine the manner of installing the coupler on the lower feeder house shaft.

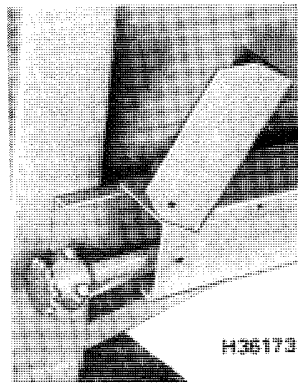

*Right-Hand Drive Shaft
443, 444*

<https://www.ebooklibonline.com>

Hello dear friend!

Thank you very much for reading.

Enter the link into your browser.

The full manual is available for immediate download.

<https://www.ebooklibonline.com>