

21C and 21S String Trimmers

(Serial No. 075001 –)

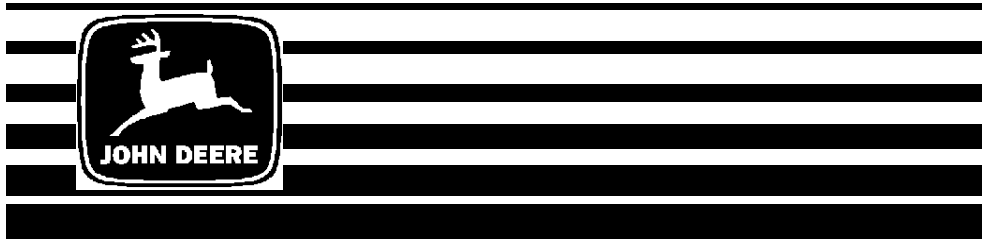

OPERATOR'S MANUAL

John Deere
Lawn & Grounds Care Division
OMM122057 H5

North American Version
Litho in U.S.A
English

INTRODUCTION

THANK YOU for purchasing a John Deere product.

Read this manual and your attachment manuals thoroughly. Failure to do so could result in personal injury or equipment damage.



C WARNING: The Engine Exhaust from this product contains chemicals known to the State of California to cause cancer, birth defects or other reproductive harm.

CALIFORNIA Proposition 65 Warning

This manual should be considered a permanent part of your machine and should remain with the machine when you sell it.

Measurements in this manual are metric units and their U.S. customary equivalents. RIGHT-HAND and LEFT-HAND sides are determined by facing in the direction the machine will travel when going forward. When you see a broken line arrow (- - - →) it indicates the part it is pointing to is hidden.

Record identification numbers below. Be sure to record all the numbers to help in tracing the machine if it is stolen. You also

Date of Purchase: _____	pers Dealer Name: _____	Phone: _____
----------------------------	----------------------------	-----------------

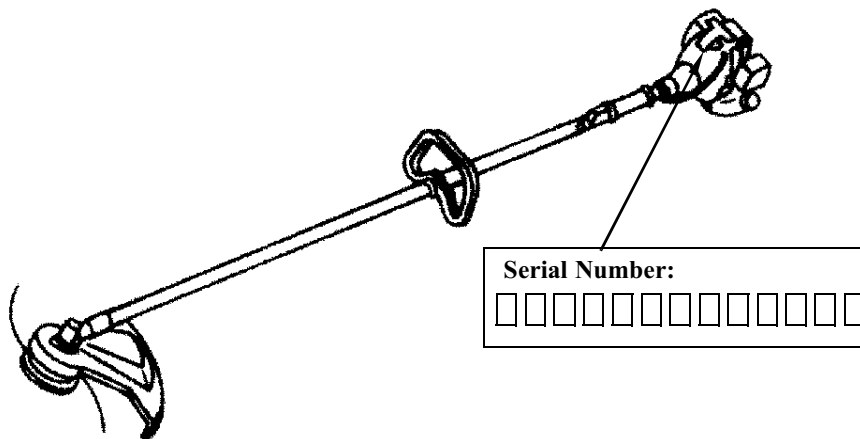

TABLE OF CONTENTS

	Page
Safety Signs	
Safety-Alert Symbol.....	1
Machine Safety Labels	1
Controls	6
Operating	
Operate String Trimmer Safely	8
Protect People And Pets.....	9
Help Prevent Serious Or Fatal Accidents	9
Handle Fuel Safely – Avoid Fires	9
Wear Appropriate Clothing	9
Adjusting Line Length	10
Adjusting Handle.....	11
Starting Cold Engine.....	11
Starting Warm Engine.....	13
Stopping Engine	13
Trimming Tips.....	14
Mowing And Scalping Tips	15
Edging And Sweeping Tips.....	16
Handle Fuel Safely	17
Filling Fuel Tank	18
Service	
Service String Trimmer Safely	19
Service Interval	19
Engine Oil	20
Mixing Fuel	20
Checking And Adding Gear Case Lubricant (21S)	22
Cleaning Fuel Filter.....	22
Checking Spark Plug	23
Replacing Air Cleaner Element.....	23
Cleaning Cylinder Fins.....	24
Lubricating Drive Shaft (21C)	26

<https://www.ebooklibonline.com>

Hello dear friend!

Thank you very much for reading.

Enter the link into your browser.

The full manual is available for immediate download.

<https://www.ebooklibonline.com>

TABLE OF CONTENTS

	Page
Service (Continued)	
Lubricating Driveshaft (21S).....	26
Removing Muffler.....	27
Adjusting Carburetor.....	29
Changing Cutting Line (21C And 21S).....	31
Replacing Spool (21C And 21S).....	32
Replacing Line Cutting Blade.....	32
Grease.....	33
Troubleshooting	
Using Troubleshooting Chart.....	34
Storage	
Storing Safety.....	35
Storing String Trimmer.....	35
Removing String Trimmer From Storage.....	36
Assembly	
Install Handle (21S).....	37
Install Shield (21C).....	37
Install Shield (21S).....	37
Install Cutting Head (21C).....	38
Install Cutting Head (21S).....	38
Specifications	
Engine.....	40
Drive.....	40
Cutter Head.....	41
Dimensions.....	41
Sound Level At Operator's Ear.....	41

TABLE OF CONTENTS

	Page
Warranty Information	
Product Warranty.....	42
John Deere Service Literature Available	
Order Form.....	43

All information, illustrations and specifications in this manual are based on the latest information at the time of publication. The right is reserved to make changes at any time without notice.

COPYRIGHT© 1995
John Deere Horicon Works
All rights reserved
Previous Editions
COPYRIGHT© 1994 and 1992

SAFETY SIGNS

Safety-Alert Symbol

Read and recognize safety information. Be alert to the potential for personal injury when you see this safety-alert symbol.

On your machine safety labels, the words DANGER, WARNING, and CAUTION are used with this safety-alert symbol. DANGER identifies the most serious hazards. In this manual, the word CAUTION and this symbol call attention to safety messages.



21C Machine Safety Labels

M60844

M71185

M60849

WARNING ▲ DANGER

This symbol is a graphic pictorial representation of a hazard. It is used to identify the most serious hazards. It is used to identify the most serious hazards. It is used to identify the most serious hazards.

- Always wear safety glasses when operating this machine.
- Prevent accidental contact with user and bystanders. ALWAYS WEAR SAFETY GLASSES.
- DO NOT OPERATE THIS MACHINE IN THE DARK.

• Cutting to reduce the risk of injury. Always use proper cutting technique. Always use proper cutting technique. Always use proper cutting technique.

• Do not remove this symbol until the machine is repaired. Do not remove this symbol until the machine is repaired. Do not remove this symbol until the machine is repaired.

SAFETY SIGNS

21S Machine Safety Labels (Continued)



M71092a



M60851

WARNING ⚠ DANGER

*This tool can be dangerous and cause serious injury if improperly used. To reduce injury risk, always wear eye protection, gloves and earplugs. Read and understand the Operator and Safety Manuals. *Blades can occur from blades that are thrown or caught over or under blades. Operators, helpers and bystanders must wear eye protection and earplugs.

*Always wear hearing protection when operating this tool.

*Prevent accidental contact with teeth and arm cutting attachment. Maintain a 30 in. (762 mm) distance. **DANGER ZONE** surrounding the operator. **ONE** of the operator, dressed in proper protective clothing should be in the **DANGER ZONE**.

*Beware of **BACKCUT Made Blade** which using this tool. Special precautions are necessary for blade operation, see your Operator and Safety Manuals. **ONLY** install approved blades on Brushcutter. **ONLY** install blades designed with proper blade shock. Unhand or, hammer, blade collar, nut & is some part.

*Each cutting attachment does not stop immediately after blade stops. Keep hands and feet clear of cutting attachment. Blade stops in shut off and cutting attachments not moving.

INSPECT BLADES BEFORE USE.

DO NOT USE DAMAGED, CRACKED, BENT, DULL OR IMPROPERLY SHARPENED BLADES.

*Do not remove shields, modify the tool or "tweak" attachments or parts not approved by Approved attachment manufacturer and help you more Operators and Safety Manuals on the side from your dealer or by writing.

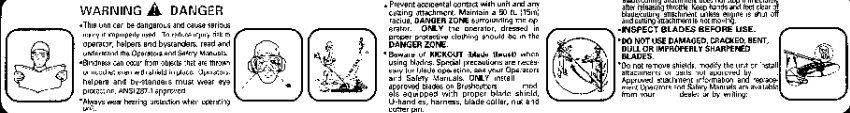

M60853c



M71188

SAFETY SIGNS

21C And 21S Machine Safety Labels (Continued)

This unit can be dangerous and cause serious injury if improperly used. Reduce injury risk to operator, helpers and bystanders, read and understand the Operators and Safety Manual.

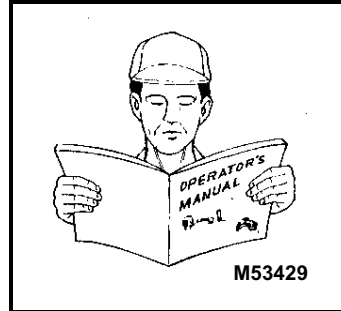

Blindness can occur from objects that are thrown or ricochet even with shield in place. Operators, helpers and bystanders must wear eye protection, ANSIZ87.1 approved.

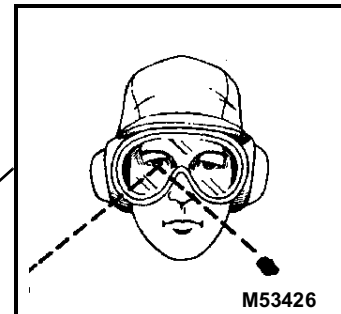

WARNING ⚠ DANGER

• This unit can be dangerous and cause serious injury if improperly used. To reduce injury risk to operator, helpers and bystanders, read and understand the Operators and Safety Manual.

• Blindness can occur from objects that are thrown or ricochet even with shield in place. Operators, helpers and bystanders must wear eye protection, ANSIZ87.1 approved.

• Always wear hearing protection when operating this machine.

• Prepare accidental operator with unit and physical attachment. Maintain a 30 ft. (10 m) safe DANGER ZONE surrounding the operator. ONLY the operator, designated people performing duties should be in the DANGER ZONE.

• DO NOT INSERT METAL BLADES

• Cut the attachment down and stop immediately after releasing the work. Keep hands and feet clear of cutting attachment until it is shut off and cutting attachment is not moving.

• Do not remove or modify the unit or installation, mounting parts and accessories. Approved attachment information is not in the Operators and Safety Manual. See available literature.

M60849

SAFETY SIGNS

21C And 21S Machine Safety Labels (Continued)

Always wear hearing protection when operating unit.

Prevent accidental contact with unit and any cutting attachment. Maintain a 50 ft. (15 m) radius, DANGER ZONE surrounding the operator. ONLY the operator, in proper protective clothing should be in the DANGER ZONE.

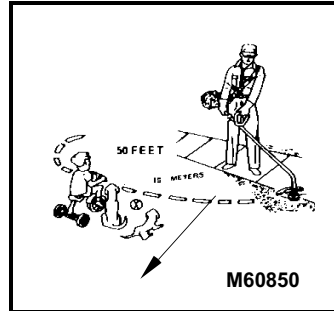

DO NOT INSTALL METAL BLADES.

Cutting attachment does not stop immediately after releasing throttle. Keep hands and feet clear of cutting attachment unless engine is shut off and cutting attachment is not moving.

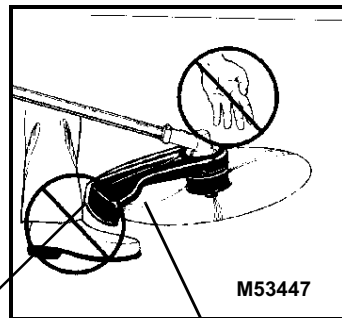

Do not remove shields, modify unit or install attachments or parts not approved by John Deere. Approved attachment information and replacement Operators and Safety

WARNING DANGER

• This unit can be dangerous and do not use it if improperly used. To reduce your risk of injury, read and understand the Operator's Manual and Safety Manual.

• Always wear hearing protection when operating unit.

• Prevent accidental contact with unit and any cutting attachment. Maintain a 50 ft. (15 m) radius DANGER ZONE surrounding the operator. ONLY the operator, dressed in proper protective clothing should be in the DANGER ZONE.

• DO NOT INSTALL METAL BLADES

• Cutting attachment does not stop immediately after releasing throttle. Keep hands and feet clear of cutting attachment unless engine is shut off and cutting attachment is not moving.

• Do not remove shields, modify the unit or install attachments or parts not approved by John Deere. Approved attachment information and replacement Operators and Safety Manual are available from your dealer or John Deere.

21C Decal Shown

SAFETY SIGNS

21S Machine Safety Labels (Continued)

Prevent accidental contact with unit and any cutting attachment. Maintain a 50 ft. (15m) radius, DANGER ZONE surrounding the operator. ONLY the operator, dressed in proper protective clothing should be in the DANGER ZONE.

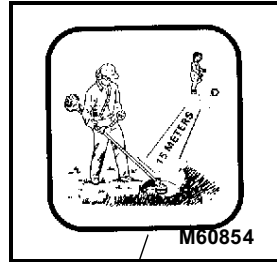

Beware of KICKOUT (blade thrust) when using blades. Special precautions are necessary for blade operation, see your Operator's and Safety Manuals. ONLY install approved blades on Brushcutters models equipped with proper blade shield, U-handles, harness, blade collar, nut and cotter pin.

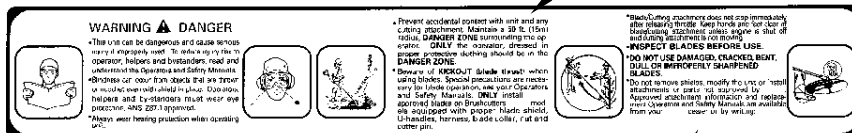
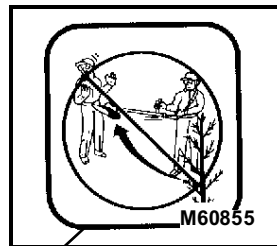

21S Decal Shown

INSPECT BLADES BEFORE USE

DO NOT USE DAMAGED, CRACKED, BENT, DULL OR IMPROPERLY SHARPENED BLADES.

DO NOT remove shields, modify the unit or install attachments or parts not approved by Deere. Approved attachment information and replacement Operators and Safety Manuals are available from your John Deere dealer.

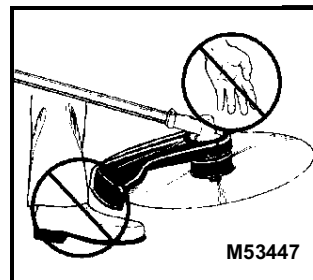

CONTROLS

Controls (21C)

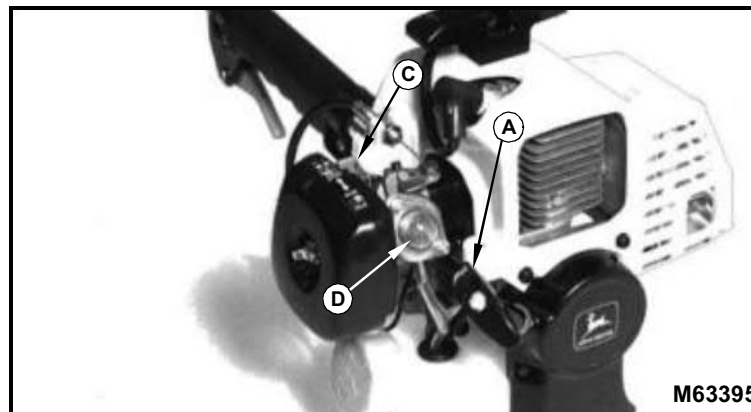
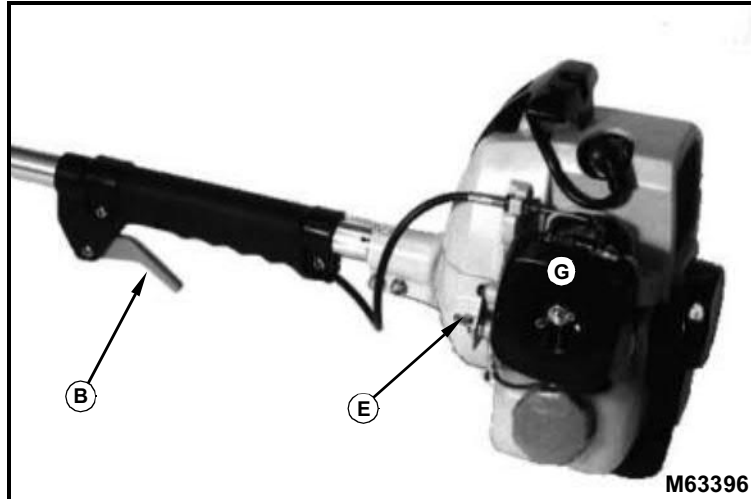

- A - Starter Handle Pull to start engine
- B - Throttle Trigger..... Controls engine speed
- C - Choke Lever..... Chokes engine for starting
- D - Primer Bulb..... Chokes engine for starting
- E - Engine Switch..... Starts engine

CONTROLS

Controls (21S)

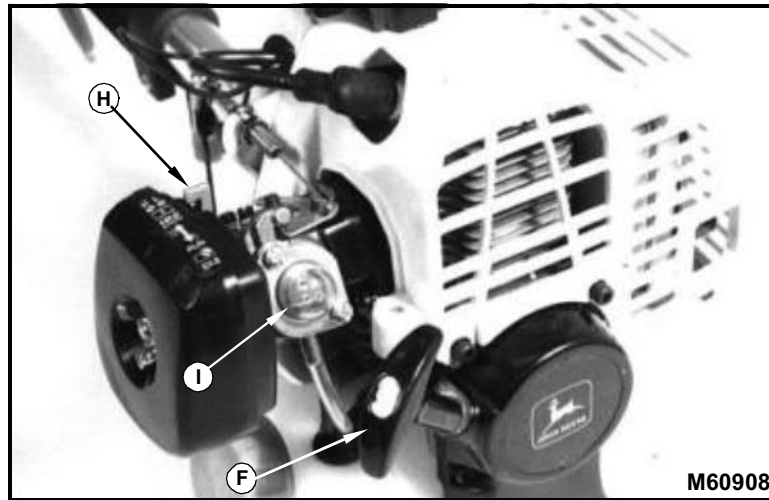
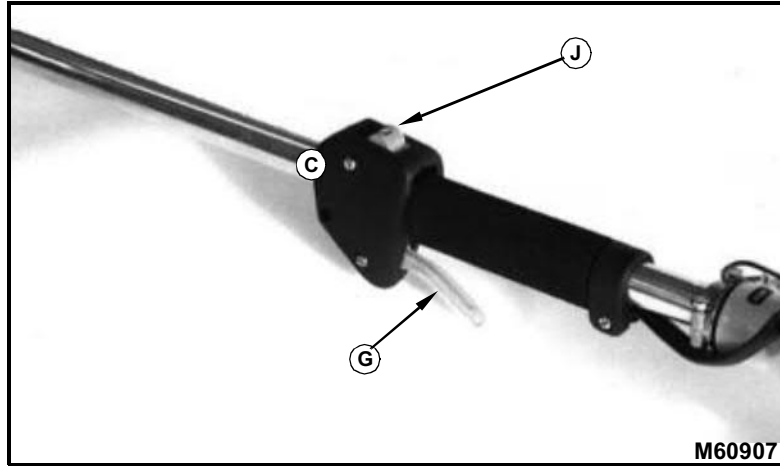

- F - Starter HandlePull to start engine
- G - Throttle Trigger Controls engine speed
- H - Choke LeverChokes engine for starting
- I - Primer BulbChokes engine for starting
- J - Engine Switch Starts engine

OPERATING

Operate String Trimmer Safely

- DO NOT wear radio or music headphones while operating the trimmer. Safe operation requires your full attention.
- Tighten parts on rotating head before you operate string trimmer.
- Start string trimmer on ground.
- DO NOT run engine in an enclosed area.
- DO NOT use string trimmer when you are tired.
- Keep hand grips clean and dry.
- Hold string trimmer firmly with both hands.
- Keep solid footing.
- Cut at ground level only.
- Trim from right to left, walking behind string trimmer. DO NOT draw string trimmer head toward you.
- DO NOT reach to make a cut.
- STOP engine before you remove debris from cutting head.
- DO NOT operate string trimmer without shield.



OPERATING

Protect People And Pets

- Keep people and pets at least 15 M (50 ft.) away.
- DO NOT let anyone operate string trimmer without proper instruction. DO NOT let children operate string trimmer.
- DO NOT leave string trimmer unattended.
- DO NOT hand string trimmer to another person while engine is running.

Help Prevent Serious Or Fatal Accidents

- Be alert at all times. People ESPECIALLY CHILDREN can move quickly into the trimming area before you know it.

Handle Fuel Safely – Avoid Fires

Handle fuel with care: it is highly flammable. DO NOT refuel machine while smoking or when near open flame or sparks.

Always stop engine and let it cool before refueling machine. Fill fuel tank outdoors.

Prevent fires by keeping machine clean of accumulated trash, grease, and debris. Always clean up spilled fuel.

DO NOT store machine with fuel in tank in a building where fumes may reach an open flame or spark.

Wear Appropriate Clothing

- Wear close fitting clothing and safety equipment appropriate for the job.
- Loud noise can cause impairment or loss of hearing, wear a suitable protective device such as earplugs.



OPERATING

Adjusting Line Length

IMPORTANT: Keep line cutting length 127 to 152 mm (5 to 6 in). Line too long will overload engine, and line too short may cause engine to overspeed.

If line is 50 mm (2 in.) or less you must lengthen it manually:

- Push and hold button (A).
- Pull line(s) to desired length.

To adjust line(s) during operation:

- Run engine at full throttle.
- Firmly tap button (A) on hard surface, not on lawn. Line extends 25 mm (1 in.) with each tap.

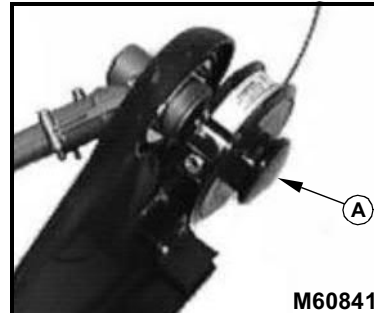
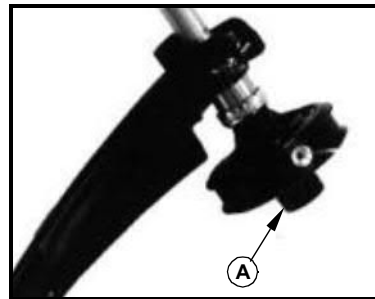

OPERATING

Adjusting Handle

IMPORTANT: DO NOT put handle assembly over caution decal.

Model 21C: Loosen wing nut (A).

Model 21S: Loosen screws (B).

Put handle assembly in desired position.

Tighten screws or wing nut.

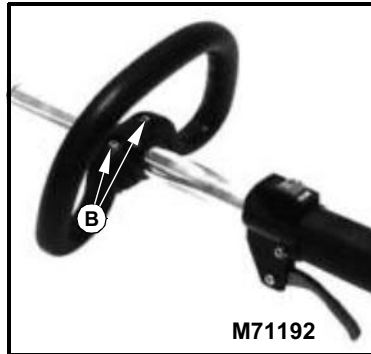
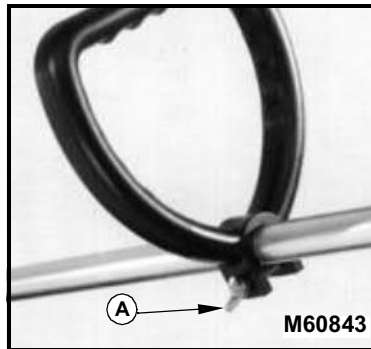

Starting Cold Engine

IMPORTANT: Avoid inhaling exhaust fumes. DO NOT operate string trimmer indoors. Start string trimmer on ground.

1. Put string trimmer on clear, level ground.
2. Support string trimmer with shield and engine.

IMPORTANT: DO NOT start string trimmer in tall grass or brush.



Suggest:

If the above button click is invalid.

Please download this document

first, and then click the above link

to download the complete manual.

Thank you so much for reading

OPERATING

3. CHOKE engine:

- Move choke lever (A) to CLOSE position.

4. Move switch (B) to ON position (21C shown).

5. Push primer bulb (C) 3 or 4 times until you see fuel in line (D).

6. Squeeze trigger (E) to FULL THROTTLE.

NOTE: Use short rapid pulls when pulling starter handle.

7. Pull starter handle. When you hear popping sound, move choke lever to HALF OPEN.

8. Pull starter handle again until engine starts.

9. Move choke lever (A) to OPEN.

10. Warm engine a few minutes at HALF THROTTLE before you cut.

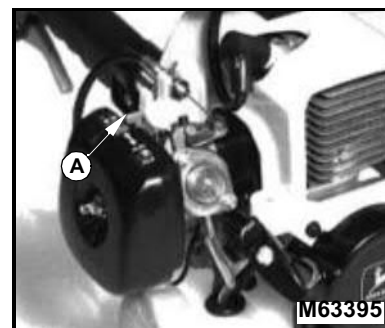
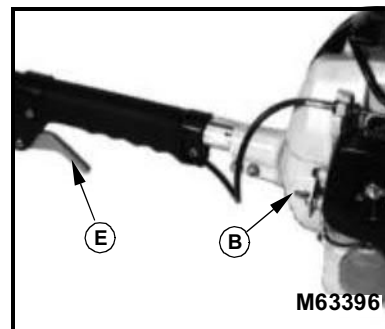
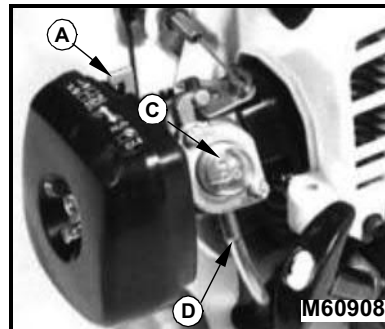

<https://www.ebooklibonline.com>

Hello dear friend!

Thank you very much for reading.

Enter the link into your browser.

The full manual is available for immediate download.

<https://www.ebooklibonline.com>