

18 One-Row Corn Picker (Effective Serial No. 18-2228)



JOHN DEERE

OPERATORS MANUAL

18 One-Row Corn Picker (Effective
Serial No. 18-2228)

OMN159076 K5 English

OMN159076 K5

LITHO IN U.S.A.
ENGLISH



FOREWORD

The purpose of this manual is to give you useful information on how to operate your new John Deere 18 Corn Picker in the many field and crop conditions under which corn is grown.

A corn picker must be built to handle a wide range of conditions. Average conditions can be handled by the standard equipment with which the machine is shipped. However, unusual conditions may require some special equipment. Your new machine will do a type of work directly proportional to the amount of care you use in operating it.

Field conditions vary from year to year, from day to day, and even from hour to hour. Different varieties of corn present widely different picking problems. A careful study of adjustments on your picker and what it will accomplish under different conditions will allow you to reap the many benefits and economies that a picker can provide.

If you find you need information not covered in this manual, see your John Deere dealer. He has the latest information on how to get the best service from your picker and can give you prompt "know-how" service in the field or in his shop.

When in need of parts, go to your John Deere dealer who carries genuine John Deere parts for your corn picker. Be sure to give him the serial number of your machine and the year purchased. This information should be recorded in the space provided on this page as soon as you have received your picker.

Serial Number.....
Date Purchased.....

You will find the Serial Number Plate on the left-hand outer wagon drawbar frame as illustrated at the right.

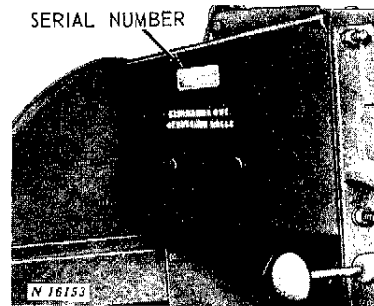

CONTENTS

	<i>Page</i>
SPECIFICATIONS	3
OPERATION	4-11
General Instructions	4-5
Tire Care and Inflation	5
Preparing Picker for Use	6
Hooking Picker to Tractor	6-9
Transporting	9
Starting Picker in the Field	10
Tilting the Machine	10
Wagon Elevator Throw-Out Control	10
How to Open the Field	10
Safety Suggestions	11
OPERATING ADJUSTMENTS	12-22
Gatherers	12-13
Snapping Rolls	13-14
Trash Knives	14
First Elevator Conveyor Auger	15
Husking Box	15-16
Husk Auger	16
Wagon Elevator	17-18
Slip Clutches	19
V-Belts	20
Chains	21
Adjusting Height of Picker (Axles)	22
Preparing Picker for Storage	22
LUBRICATION	23-29
PICKING DIFFICULTIES	30-34
SPECIAL EQUIPMENT	35-36
Wheel Scraper	35
Trash Mover	35
Wheel Shield and Down Corn Lifter	36
Cleaning Fan	36
Steel Flareboards for Wagon Box	36
SERVICE	37-38
ASSEMBLY	39-50

<https://www.ebooklibonline.com>

Hello dear friend!

Thank you very much for reading.

Enter the link into your browser.

The full manual is available for immediate download.

<https://www.ebooklibonline.com>

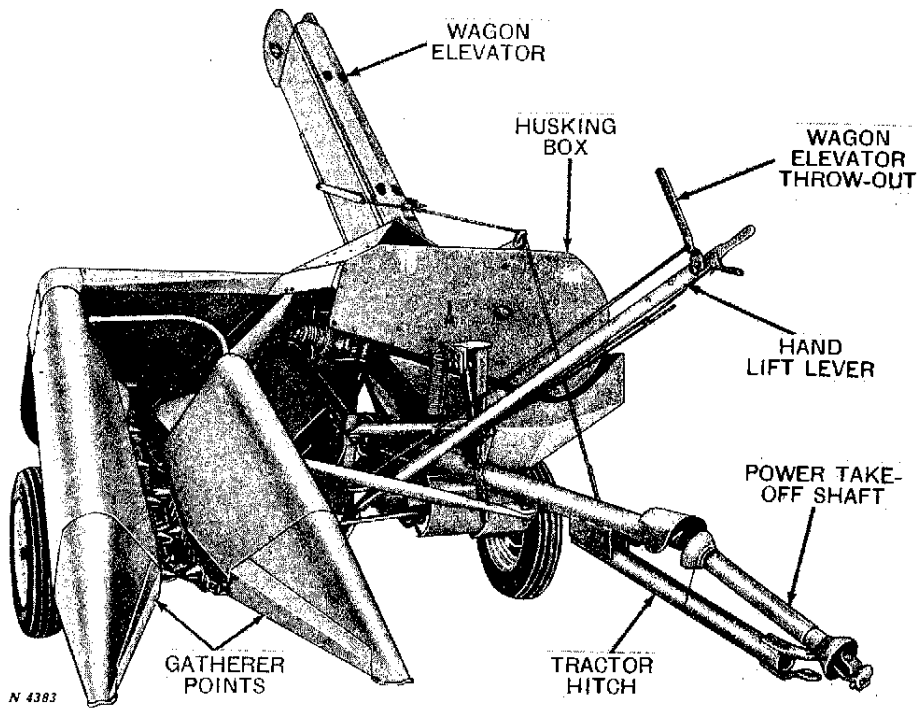

John Deere 18 Corn Picker

SPECIFICATIONS

No. of rows.....	1
Right- or left-hand machine.....	Right-hand
Lift mechanism.....	Hand lift or hydraulic remote cylinder
Distance from tractor drawbar hitch hole to corn row.....	60 inches
Gatherer points hinged or rigid.....	Hinged
Gatherer points hinged above or below gatherer chain.....	Above
Gatherer points, height of lift at hinge point (adjustable).....	0 to 24 inches
No. of gatherer chains.....	3
Type of gatherer chains.....	Steel link detachable
Minimum clearance between gatherer chains and ground.....	0 inches
Gatherer chains ahead of snapping roll entry.....	Yes
Length of snapping rolls (including points).....	41 inches
Snapping roll adjustment.....	Crank
Type of first elevator conveyor.....	Auger
No. of husking rolls.....	6
Diameter of husking rolls.....	3 inches
Length of husking rolls.....	27-1/2 inches
Type of husking rolls:	
Rubber roll.....	Spiral grooved and notched
Mating rubber roll.....	Smooth tire carcass type
Cleaning fan.....	Available as special equipment
Depth ear corn elevator.....	8-1/2 inches
Width ear corn elevator.....	9 inches
Wagon elevator location.....	In line with tractor
Shelled corn saver.....	Incorporated with husk auger and housing
Width over-all of picker.....	7 feet, 11 inches
Length from tractor hitch point to wagon hitch point.....	10 feet, 7-1/2 inches
Length including wagon elevator.....	18 feet
*Height less wagon elevator.....	5 feet, 6 inches
*Height to top of wagon elevator.....	9 feet, 9 inches
Tractor power requirement.....	John Deere "1010," or larger or equivalent (tractor can be equipped with 540 or 1000 rpm PTO)

*Adjustable wheel brackets in the 4-inch raised position.

(Specifications and design subject to change without notice.)

OPERATION

GENERAL INSTRUCTIONS

Successful operation, the maximum saving of corn, quality of work, and the length of life of your John Deere 18 Corn Picker depend very largely upon thorough lubrication, proper adjustment of all chains, V-belts, slip clutches, and upon making the best use of the simple adjustments that are provided to meet varying crop conditions.

Pick Early. One of the main advantages of owning a picker is its capacity for work enabling one to finish picking while conditions are most favorable. The John Deere 18 will handle the job under any conditions as well or better than other pickers. However, we recommend picking early and avoiding the troubles and disagreeable features that accompany frozen ground, extremely cold weather, and dried-out, frozen, and rotten stalks.

Ear corn that is not going to be artificially dried, should not be cribbed if it exceeds 20 to 22 per cent moisture. If using a dryer, or high moisture storage, picking can start when the corn is 28 to 30 per cent moisture. See your local county agent for more details.

In average conditions, the picker will do its best work when traveling at a low rate of speed. Avoid excessive travel and powershaft speeds. The tractor should operate at approximately 540 rpm or 1000 rpm under load.

The machine should travel in the same direction that the field was last cultivated.

Listen for slipping clutches and watch for deep furrows, rocks, or other obstructions, with which gatherer points may strike.

Drive tractor carefully so the gatherer points will follow the row. When crossing end of the field, raise the gatherer points by tilting machine.

If, for some reason, the picker becomes clogged, stop the tractor engine and then remove the obstacle from the machine. **Never use a corn stalk or stick to clean the snapping rolls while the power take-off is engaged. Keep hands and feet away from snapping rolls when the machine is running.**

If trouble is experienced, determine where it exists before making any adjustment. Make no adjustments until all paint is worn off the slip clutches and working parts are smooth.

Before putting the picker in the field for the first time, lubricate thoroughly and operate slowly for some time, making sure that all parts are working freely. If there is no binding or heating, run at full speed for a few minutes. Next, go over the entire machine to be sure that all bolts are

tight and that lubricant is reaching all bearings. Be sure to check the tension on all chains and V-belts.

IMPORTANT: Keep all nuts, pins, and keys tight. Keep cotter pins spread. Carry a wrench when lubricating the machine so that loose nuts can be tightened as they are discovered.



Never adjust a picker while it is in motion. Be sure to stop the tractor engine. Too much care cannot be taken to keep hands and clothing away from all moving parts.

Take pride in doing the best work possible under all conditions. In order to achieve this, follow the rows carefully; set gatherers and tilt the machine to pick the down and leaning stalks; set snapping rolls so that corn is not mutilated or shelled excessively; and to meet damp or dry conditions of corn. Handy adjustments are provided to meet these conditions. Above all, be a safe operator and follow all the safety suggestions mentioned in this manual.



TIRE CARE AND INFLATION

It is very important that tires be kept properly inflated as considerable damage may result to the tire when proper pressure is not maintained.

Your new picker was shipped from the factory with correct pressure of 28 psi in both 5.90 x 15—4-ply rib implement tires. However, check the pressure before moving the machine.

**A Careful Operator
IS THE BEST INSURANCE
AGAINST AN ACCIDENT**

—National Safety Council

PREPARING PICKER FOR USE

Before starting your corn picker in the field, be sure you are thoroughly familiar with the function of each working unit. A careful study of the adjustments and what they will accomplish under the wide variety of field conditions will allow you to reap the many benefits that an 18 Corn Picker can provide.

Careful inspection of the corn picker before starting work each day will prevent needless delays and break-downs in the field. Make the following checks and adjustments.

1. Perform the lubrication services (pages 23 through 29).
2. Inspect all drive chains for proper tension. Tighten chains only enough to prevent links from climbing sprocket teeth.
3. Inspect the snapping roll, fan, and first elevator auger drive V-belts for proper tension (page 20).
4. Check the gatherer chain adjustments (page 13).
5. Check the wagon elevator chain adjustment (page 18).
6. Check for loose bolts and connections.
7. Check tire inflation. The correct air pressure is 28 psi.
8. A new picker should be given an empty running "break-in" period of at least 10 minutes. Run the picker for about three or four minutes at slow speed, then stop the machine and inspect it completely for loose bolts, heating bearings, binding parts, or loose belts and chains. Start the picker again and complete the "break-in" period increasing the picker speed the last 3 minutes. After the "break-in" period, again inspect for loose bolts, heating bearings, or similar undesirable conditions.

HOOKING PICKER TO TRACTOR

Before attaching the picker to the tractor, set the tractor drawbar in the low position, with the hole in the drawbar behind the end of the power take-off shaft and in line with the shaft. See the illustration at the right.

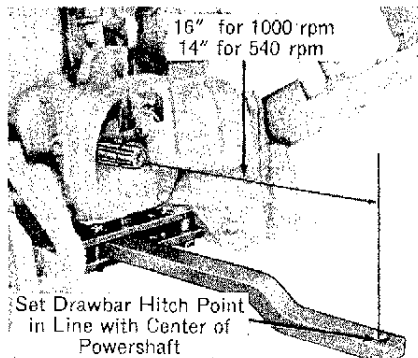

HOOKING PICKER TO TRACTOR—Continued

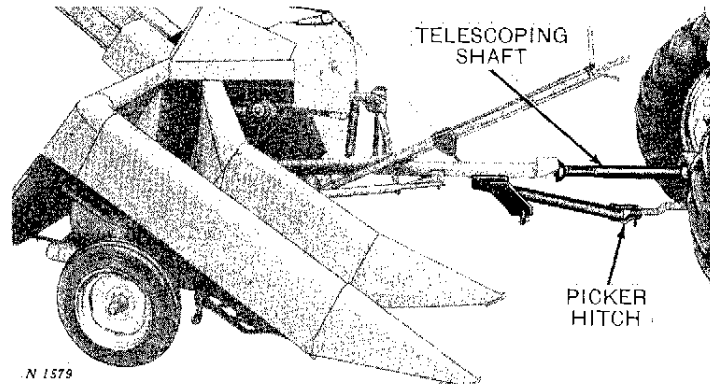

Back the tractor to the picker and attach the hitch to tractor. Depress the lock pin on the telescoping shaft universal joint and slide the universal joint on the tractor power take-off shaft. Release the lock pin, making sure it is properly seated in groove in the power take-off shaft.

ATTACHING HYDRAULIC REMOTE CYLINDER

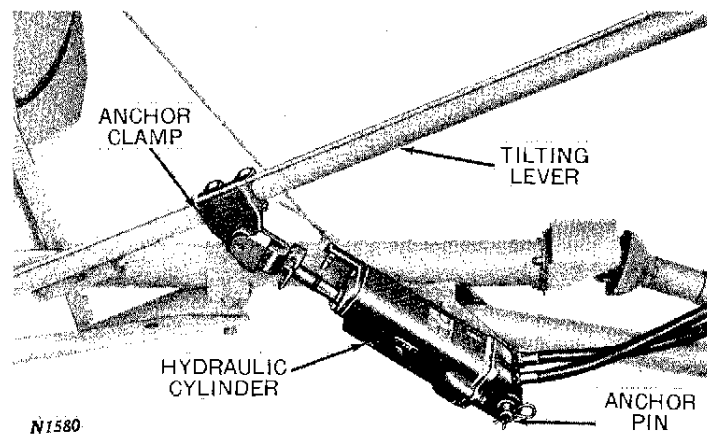

Attach the hydraulic remote cylinder to the anchor pin and anchor bracket as shown. Attach the hydraulic hoses to the forward end of the tilting lever with the S-hook, spring, and hose bracket (not illustrated). The anchor clamp must be positioned on tilting lever so that when the cylinder is extended, the first elevator housing will not strike the wagon elevator.

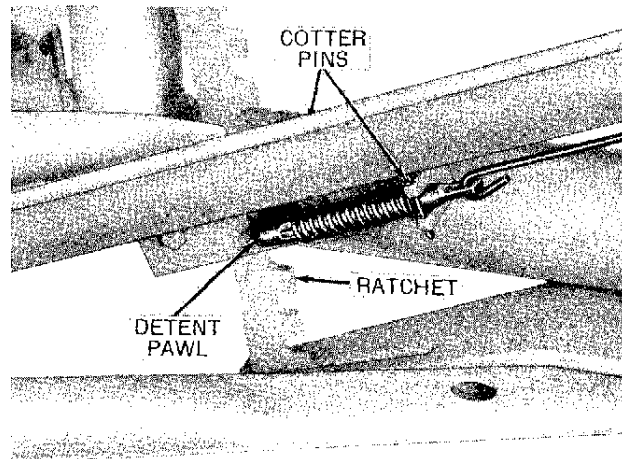

N 1581

Before operating the hydraulic cylinder, remove the two cotter pins holding the detent pawl and remove the pawl from the ratchet. Then disconnect the detent rod from lever handle.

When removing the hydraulic cylinder, reinstall the detent pawl *first*.

ADJUSTING HAND LIFT LEVER

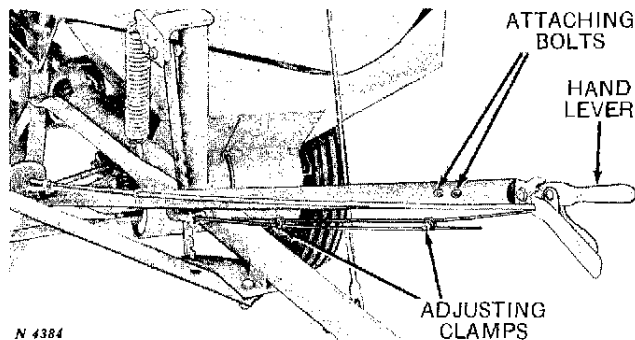

N 4384

The hand lift lever can be lengthened or shortened for the convenience of the tractor operator. To adjust the lever, loosen the two adjusting clamps on the hand lever and remove the two attaching bolts.

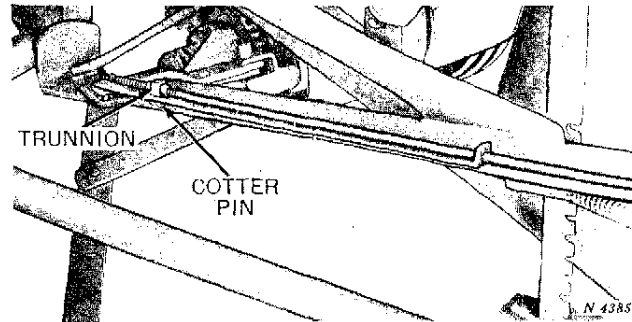

When adjusting the hand lever, the trunnion on the throw-out lever rod must be removed from the adjusting strap and repositioned to the new setting. After the desired position has been obtained, secure the attaching bolts, clamps and the trunnion in their proper places.

TRANSPORTING

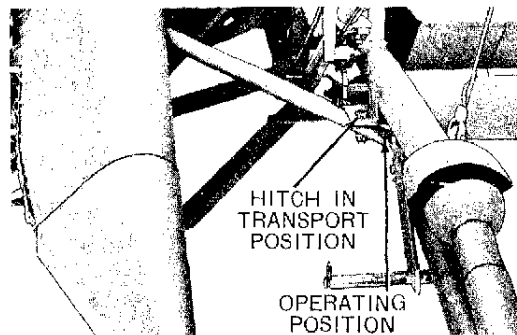

In order to reduce the over-all width of the corn picker for transporting, the hitch may be swung toward the gatherer sheets. Remove the bolt holding the hitch in operating position as shown in the illustration and move the hitch to transporting position. Replace the bolt.



CAUTION: When transporting the Corn Picker on a road or highway at night or during the day, use accessory lights and devices for adequate warning to the operators of other vehicles. In this regard, check local governmental regulations. Various safety lights and devices are available from your John Deere dealer.

STARTING THE PICKER IN THE FIELD

TILTING THE PICKER

Under most field conditions, the picker should be operated so the gatherer points just touch the ground. Raise the gatherer points to clear obstructions, ditches, and when crossing rows. The machine is tilted easily with the tilting lever of the hand lift picker as illustrated below or with the tractor hydraulic system on the hydraulic remote cylinder operated picker.

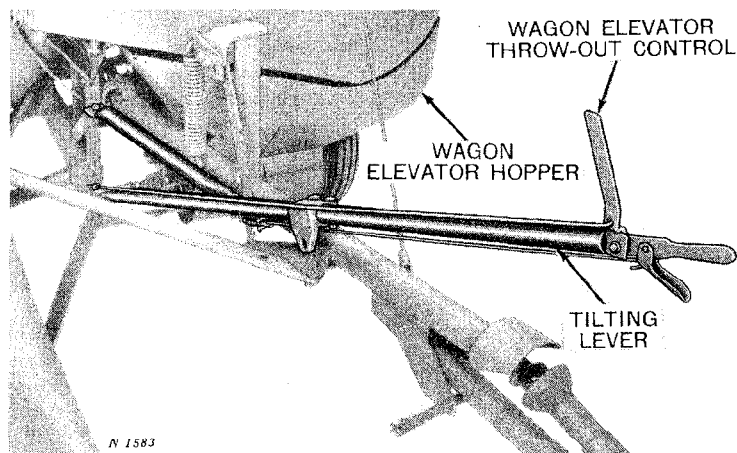

WAGON ELEVATOR THROW-OUT CONTROL

The wagon elevator throw-out control handle is conveniently located near the tractor seat. This handle is used to stop the wagon elevator when it is desirable to continue running the picker such as when turning at row ends. The wagon elevator hopper has ample capacity for holding the corn while turning at the end of the rows.

HOW TO OPEN THE FIELD

When opening the field, it is best to pick across the ends or around the field several times to provide sufficient space for turning. Because of the close-coupled wagon hitch, low over-all width, and compactness of the 18 Corn Picker, only two rows of standing corn are knocked down when opening fields or lands. When picking down rows, the picker should run in the opposite direction that it traveled when making down rows. Drive slowly.

After the field has been opened, pick in the same direction as the field was last cultivated.

SAFETY SUGGESTIONS

BEFORE OPERATION

1. Review this Operator's Manual. Understand the function of all working parts.
2. Do not wear loose fitting clothing—they may catch in moving parts.
3. When refueling, ground hose nozzle or can and funnel. Do not smoke.
4. Fire extinguisher should be in place and in good operating condition.
5. Make sure everyone is clear before starting the machine.
6. Do not permit anyone on the tractor except those required for its operation.
7. See that all safety shields are in place and properly secured before starting to operate the picker.
8. Be sure the correct PTO parts are used and properly secured.
9. Keep the picker in good repair. Less plugging will occur if all components are functioning properly.
10. After servicing, be sure all tools, parts, or service equipment are removed before starting the machine.

DURING OPERATION

1. Before starting tractor engine, be sure all controls are in neutral.
2. Avoid the possibility of fire by keeping the tractor and picker free of trash.
3. Use extreme care when operating close to ditches, fences, or on hillsides.
4. Keep hands and feet away from moving parts.
5. Stop tractor engine before lubricating, cleaning, or adjusting the machine.
6. Keep tractor in gear when going down grade.
7. Do not leave tractor seat without disengaging PTO drive and stopping engine.
8. Never attempt to remove obstructions from snapping or husking rolls while the rolls are in motion.

AFTER OPERATION

1. Do not disconnect wagon on incline without first blocking the wheels.

ON HIGHWAY OPERATION

1. Check clearance carefully before driving machine under electric lines, bridges, or into buildings.

OPERATING ADJUSTMENTS

GATHERERS

GATHERER POINTS

The gatherer points are hinged to follow the contour of the ground. They can also be raised and locked in any one of a number of positions.

When operating, have the gatherer points just touching the ground.

In muddy conditions or in snow, raise and lock the gatherer points high enough to prevent the points from scooping material into the throat opening thereby clogging the opening.

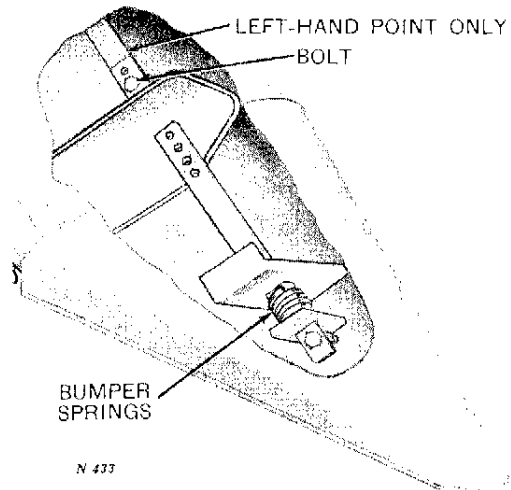

GATHERER CHAINS

The three gatherer chains on the 18 Corn Picker provide better gathering of down and tangled stalks and also provide better gathering in rough fields.

The gatherer chains run well beyond the points of the snapping rolls. Chains can be run touching the ground if necessary to bring low-hanging ears and down stalks into the snapping rolls.

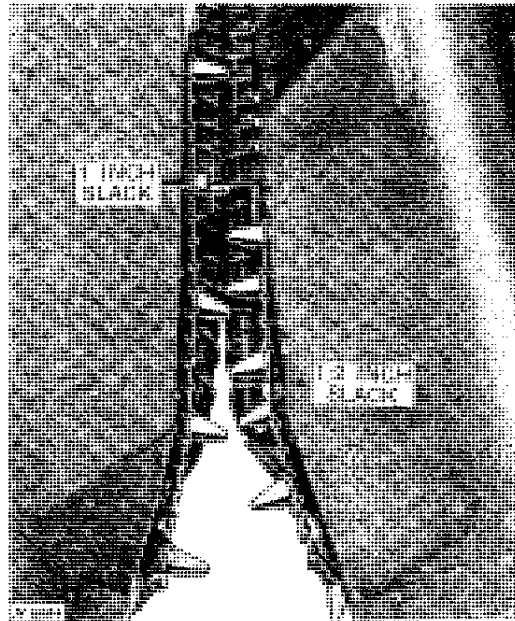



Suggest:

If the above button click is invalid.

Please download this document

first, and then click the above link

to download the complete manual.

Thank you so much for reading

Gatherer Chain Adjustment

Each gatherer chain is adjusted at the front tightener sprocket. Loosen the nut on top of the sprocket and move the tightener cam until proper chain tension is obtained and then retighten the nut. Proper chain tension exists when there is approximately 1-inch of slack on the outer chain and 1/2-inch on the inner chain at a point midway along the guide plate as shown on page 12.

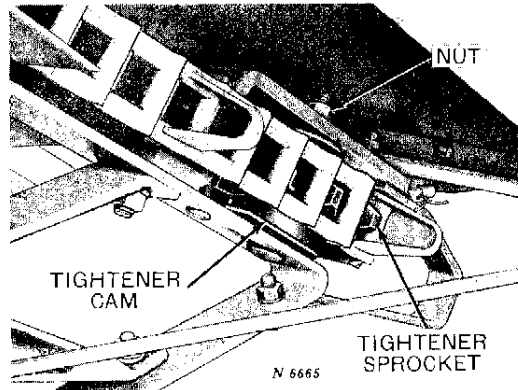

SNAPPING ROLLS

Snapping roll spirals move stalks up the rolls. Flutes between the spirals pull stalks through the rolls and snap off the ears.

Reduce field losses to a minimum by keeping snapping rolls properly timed and adjusted.

Timing the Rolls

1. Remove belt from snapping roll drive sheave at rear of picker.
2. Remove spring pin and pull drive sheave off snapping roll gudgeon.
3. Remove spur gear.
4. Time cam barrel (upper roll section) by rotating rolls so lugs on one roll do not strike lugs on the other roll. Each snapping roll should rotate freely.

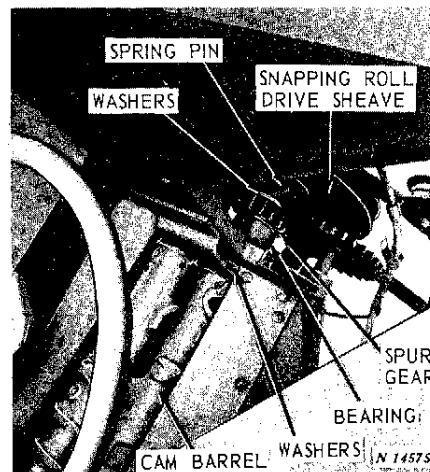
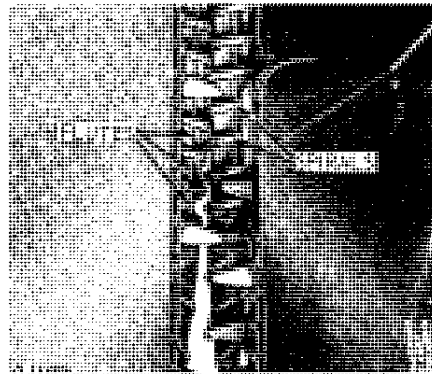

<https://www.ebooklibonline.com>

Hello dear friend!

Thank you very much for reading.

Enter the link into your browser.

The full manual is available for immediate download.

<https://www.ebooklibonline.com>