

JOHN DEERE
WORLDWIDE COMMERCIAL & CONSUMER
EQUIPMENT DIVISION

2-Bag Bagger
For EZtrak™ Series

OMM162319 L9

OPERATOR'S MANUAL



JOHN DEERE

Original Instruction

All information, illustrations and specifications in this manual are based on the latest information at the time of publication. The right is reserved to make changes at any time without notice.

COPYRIGHT© 2009

Deere & Co.

**John Deere Worldwide Commercial and
Consumer Equipment Division**

All rights reserved

Previous Editions

COPYRIGHT©

North American Version

Litho in U.S.A.

INTRODUCTION

Introduction

Using Your Operator's Manual

Read this entire operator's manual, especially the safety information, before operating.

This manual is an important part of your machine. Keep all manuals in a convenient location so they can be accessed easily.

Use the safety and operating information in the attachment operator's manual, along with the machine operator's manual, to operate and service the attachment safely and correctly.

If your attachment manual has a section called Preparing the Machine, it means that you will have to do something to your tractor or vehicle before you can install the attachment. The Assembly and Installation sections of this manual provide information to assemble and install the attachment to your tractor or vehicle. Use the Service section to make any needed adjustments and routine service to your attachment.

If you have any questions or concerns with the assembly, installation, or operation of this attachment, see your local John Deere dealer or call the John Deere Customer Contact Center at 1-800-537-8233 for assistance.

Warranty information on this John Deere attachment can be found in the warranty that came with your John Deere tractor or vehicle.

Product Identification

Product Compatibility

2-Bag Bagger

The 2-Bag Bagger is compatible with the Z225, Z245, Z425 and Z445 Residential Zero Turn Mowers Serial No. (- 080000).

Record Purchase Information

Record your purchase information in the spaces provided below.

DATE OF PURCHASE:

DEALER NAME:

DEALER PHONE:

Register Your Product and Warranty Online

To register your product through the Internet, simply go to www.JohnDeereWarrantyRegistration.com. Completing the information, either online or with the product warranty card, will ensure the customer that their product receives all post sales service and important product information.

Safety Labels



Understanding The Machine Safety Labels

The machine safety labels shown in this section are placed in important areas on your machine to draw attention to potential safety hazards.

On your machine safety labels, the words DANGER, WARNING, and CAUTION are used with this safety-alert symbol. DANGER identifies the most serious hazards.

The operator's manual also explains any potential safety hazards whenever necessary in special safety messages that are identified with

the word, CAUTION, and the safety-alert symbol.

There can be additional safety information contained on parts and components sourced from suppliers that is not reproduced in this operator's manual.

WARNING M158109

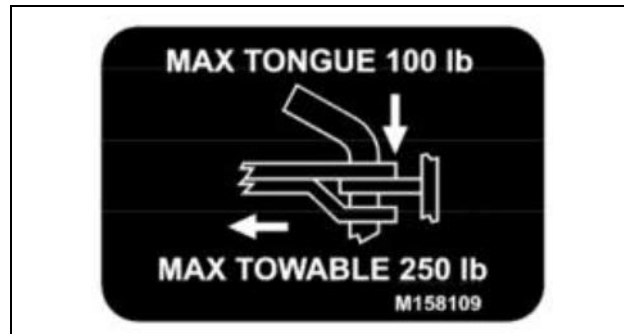

M158109

MAX TONGUE 100 LB

MAX TOWABLE 250 LB

WARNING

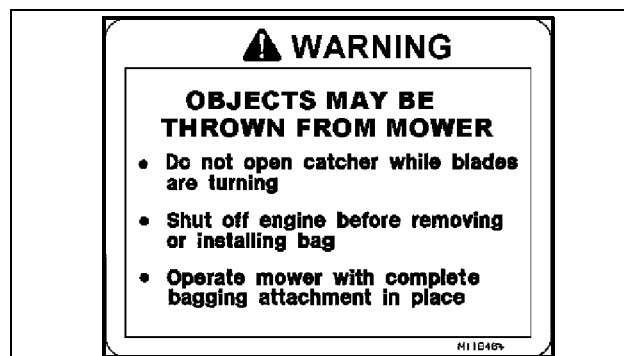

M118464

Objects May Be Thrown from Mower

- Do not open catcher while blades are turning.
- Shut off engine before removing or installing bag.
- Operate mower with complete bagging attachment in place.

WARNING

Thrown Objects

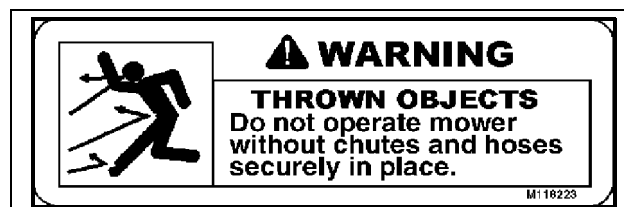

M118223

- Do not operate mower without chutes and hoses securely in place.

CAUTION

SAFETY

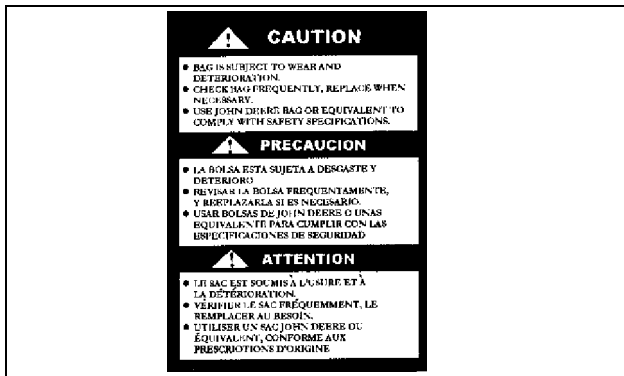

GC00215

- Bag is subject to wear and deterioration.
- Check bag frequently and replace when necessary.
- Use John Deere bag or equivalent to comply with safety specifications.

Safety

Read Safety in Machine Operator's Manual

Read the general safety operating precautions in your machine operator's manual for additional safety information.

Operating Safely

Read, understand and follow all instructions in this attachment manual, the machine operator's manual and safety signs on equipment before starting.

Use proper front ballast. Remove ballast when the material collection system is removed.

Hopper extends beyond machine. Be aware of surrounding objects when making short turns.

Do not operate material collection system unless entire grass catcher is fastened in place with hopper cover securely latched.

Do not let anyone ride on the mower or material collection system. Riders are subject to injury such as being struck by foreign objects or being thrown off. Riders may obstruct the operator's view and cause a collision.

Before bag removal or installation:

- Stop mower.
- Disengage mower or PTO.
- Stop engine and remove key.
- Wait for engine and all moving parts to stop before leaving the operator seat.

Before backing up machine:

- Stop machine.
- Look behind hopper for children.
- Keep bystanders away when unloading material collection system.

Operate safely on slopes:

- Empty bags when they are half full.
- Do not operate on steep slopes.
- Before turning, slow down.
- Avoid sudden starts and stops.
- Do not park machine with material collection system on slopes.

Bag and Hose Maintenance:

- Bag and hose are subject to wear and deterioration.
- Check bag and hose frequently; replace when necessary.
- Use John Deere bag and hose or equivalent to comply with safety specifications.
- Do not leave clippings in bags overnight.

Parking Safely

1. Stop machine on a level surface, not on a slope.
2. Disengage mower blades or any other attachments.
3. Lower attachments to the ground.
4. Lock the park brake.
5. Stop the engine.
6. Remove the key.
7. Wait for engine and all moving parts to stop before you leave the operator's seat.
8. Close fuel shut-off valve, if your machine is equipped.
9. Disconnect the negative battery cable or remove the spark plug wire(s) (for gasoline engines) before servicing the machine.

Protect Children

- Tragic accidents can occur if the operator is not alert to the presence of children. Keep children indoors when the machine and attachment are operated and under the watchful care of another responsible adult.
- Never assume that children will remain where you last saw them. Stay alert to the presence of children. Turn the machine off if a child enters the work area.
- Do not let children or an untrained person operate the machine.
- Do not carry or let children ride on any attachment or machine even with the attachment off. Do not tow children in a cart or trailer.

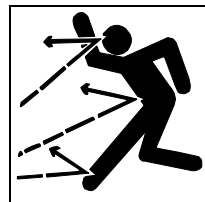

Avoid Injury From Thrown Objects

- When operating the vehicle with the MCS attachment installed make sure all chutes and hoses are securely in place. Keep hopper closed or MCS in operating position.
- Stop the engine and wait for all moving parts to stop before removing or lifting any attachment components.
- Avoid injury from impeller blades and thrown objects. Remove attachment when operating vehicle in side discharge mode. Make sure deflector shield is in place on mower deck if attachment is removed.



Avoid Injury From Rotating Blades

- Keep hands and feet away from rotating blades and blower assembly when engine is running.
- Stop engine and wait for moving parts to stop before servicing components.
- Do not operate MCS or blower unless all attachment components are in place and latched.

<https://www.ebooklibonline.com>

Hello dear friend!

Thank you very much for reading.

Enter the link into your browser.

The full manual is available for immediate download.

<https://www.ebooklibonline.com>

SAFETY

Practice Safe Maintenance

- Only qualified, trained adults should service this machine.
- Understand service procedure before doing work. Keep area clean and dry.
- Do not operate the engine in a confined space where dangerous carbon monoxide fumes can collect.
- Never lubricate, service or adjust the machine or attachment while it is moving. Keep safety devices in place and in working condition. Keep hardware tight.
- Keep hands, feet, clothing, jewelry, and long hair away from any moving parts, to prevent them from getting caught.
- Lower any attachment completely to the ground or to an existing attachment mechanical stop before servicing the attachment. Disengage all power and stop the engine. Lock park brake and remove the key. Let machine cool.
- Disconnect battery or remove spark plug wire (for gasoline engines) before making any repairs.
- Before servicing machine or attachment, carefully release pressure from any components with stored energy, such as hydraulic components and springs.
- Release hydraulic pressure by lowering attachment or cutting units to the ground or to a mechanical stop and move hydraulic control levers.
- Securely support any machine or attachment elements that must be raised for service work. Use jack stands or lock service latches to support components when needed.
- Never run engine unless park brake is locked.
- Keep all parts in good condition and properly installed. Fix damage immediately. Replace worn or broken parts. Replace all worn or damaged safety and instruction decals.
- Check all hardware at frequent intervals to be sure the equipment is in safe working condition.
- Do not modify machine or safety devices. Unauthorized modifications to the machine or attachment may impair its function and safety.

ASSEMBLY

Assembly

Identify Parts (42 and 48 in. Mower Deck)

Bagger and Hopper Parts

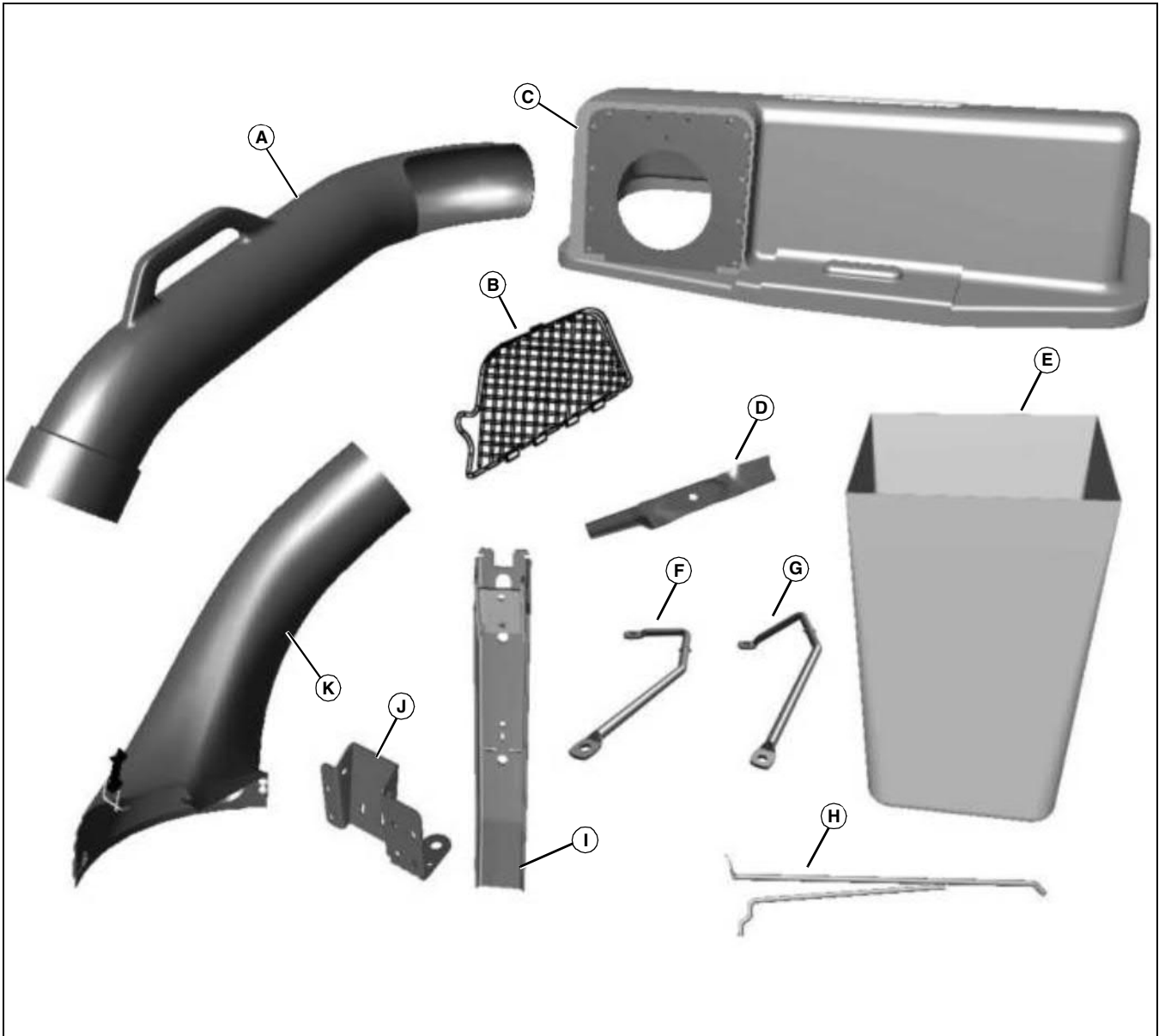

MX44777

Qty.	Description	Qty.	Description
1	Upper Discharge Chute (A)	1	Support Rod (2009 and newer) (G)
1	Hopper Screen (B)	1	Latch Rod (H)
1	Hopper Top (C)	1	Mounting Post (I)
3	Blade, 48 in. High Lift (Bagging) (D)	1	Mounting Post Bracket (J)
2	Grass Bag (E)	1	Lower Discharge Chute (K)
1	Support Rod (2008 and earlier) (F)		

ASSEMBLY

Bag of Parts

NOTE: Additional flat washer included for hopper top latch adjustment, if needed.

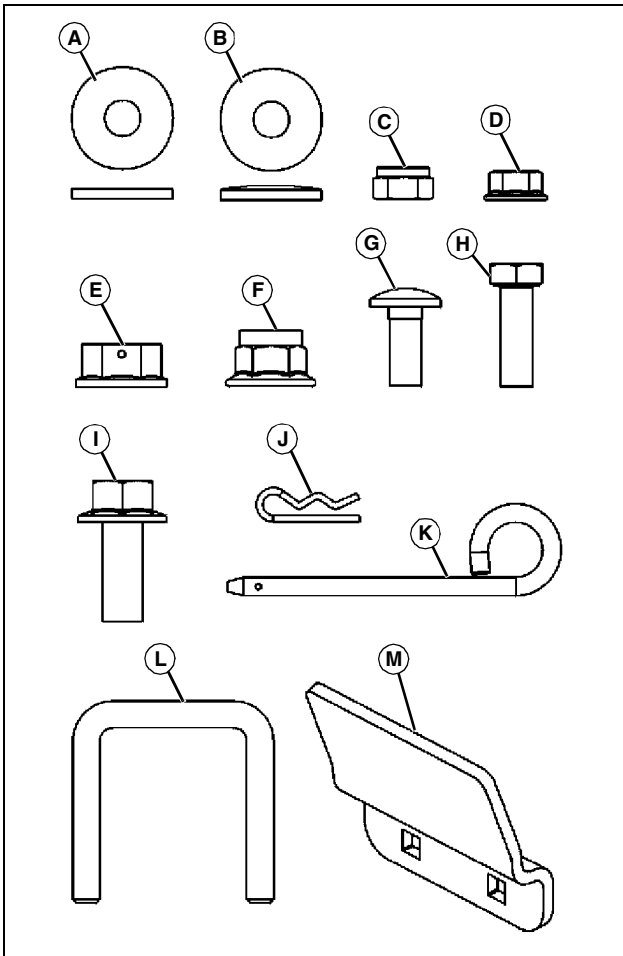

MX37835

Qty. Description

3 Tie Strap (not shown)

Assemble Hopper Screen to Hopper Top

IMPORTANT: Avoid damage! Allowing the hopper to contact abrasive surfaces can cause scratching.

1. Place hopper top upside down on a protective surface.

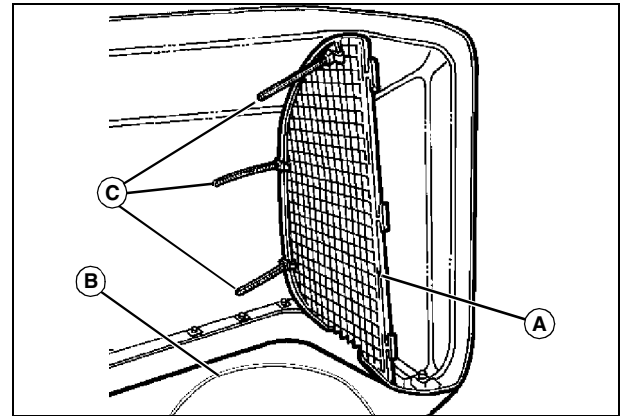

M96099

2. Insert the hopper screen (A) inside the hopper top so it fits between tabs located between chute hole (B) and side of hopper top.

Fasten hopper screen to tabs with three tie straps (C). Put tie straps through holes in hopper top tabs and slots in screen.

3. Pull tie straps tight and cut off excess.

Qty. Description

- 1 Washer, Flat, M8.4 (A)
- 4 Washer, Spring (B)
- 3 Locknut, M8 (C)
- 2 Nut, Flange, M8 (D)
- 6 Nut, Flange, 3/8 in. (E)
- 2 Locknut, Nylon Insert, M10 (F)
- 3 Bolt, Carriage, M8x20 (G)
- 3 Bolt, Hex Head, M8x25 (H)
- 2 Bolt, Flange Head, M10x25 (I)
- 1 Pin, Spring Locking (J)
- 1 Pin, Drilled (K)
- 3 U-Bolt (L)
- 1 Bracket, Stop (M)

ASSEMBLY

Assemble Support Rod to Mounting Post

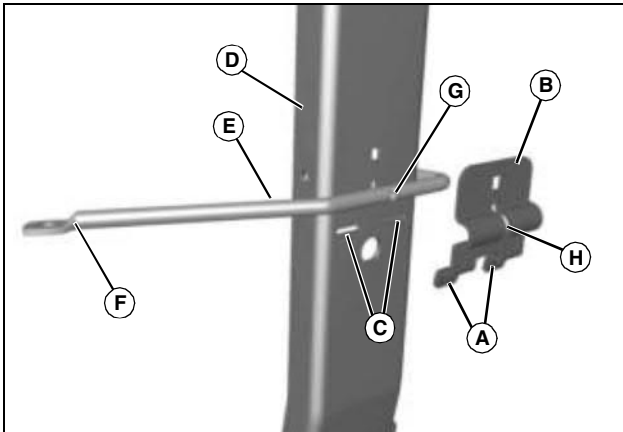

MX41668

Picture Note: 2008 and older version.

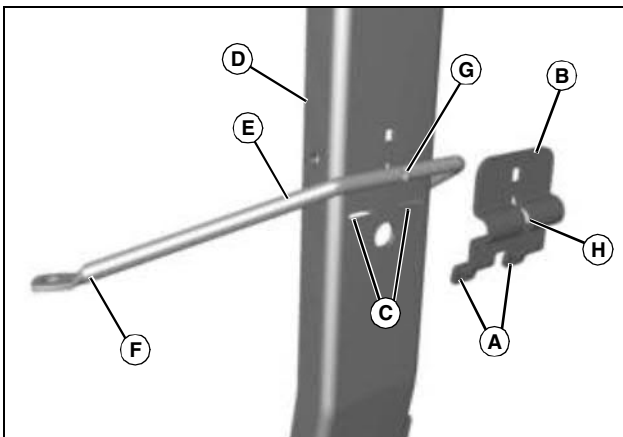

MX41669

Picture Note: 2009 and newer version.

1. Fit tabs (A) on support rod bracket (B) into slots (C) on mounting post (D).
2. Insert support rod (E) between support rod bracket and mounting post:
 - When viewed from rear, the longer end (F) of rod (E) should be faced toward the left.
 - Flat side of drilled ends on support rod must be facing down.
 - Tab (G) on support rod must fit into slot (H) on support rod bracket before tightening.

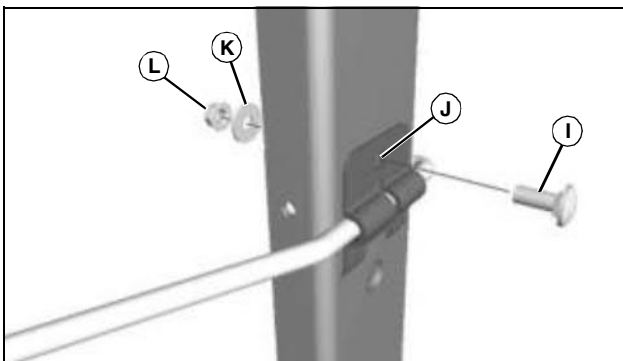

MX37802

3. Insert M8x20 carriage bolt (I) through support rod bracket and hole (J)

in mounting post.

4. Secure bolt with M8.4 flat washer (K) and M8 locknut (L).

Assemble Latch Rod to Mounting Post

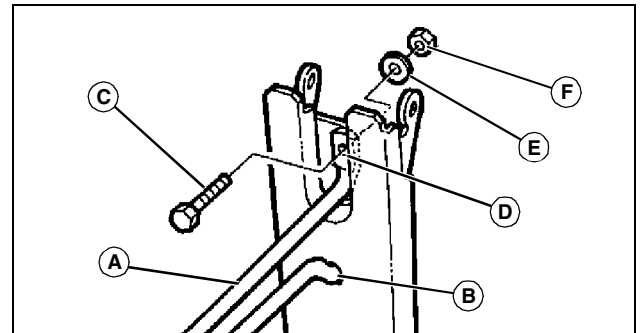

MX8875a

1. Insert lower part of latch rod (A) through hole (B) in mounting post.
2. Fasten upper part of latch rod with hex bolt (C) through latch rod end (D) and post hole, and secure with flat washer (E) and M8 lock nut (F).

Assemble Mounting Post to Hopper Top

NOTE: After hopper top is installed to the machine, raise and lower hopper top several times and adjust hardware if necessary for tightness.

1. Place hopper top upside down on a protective surface.

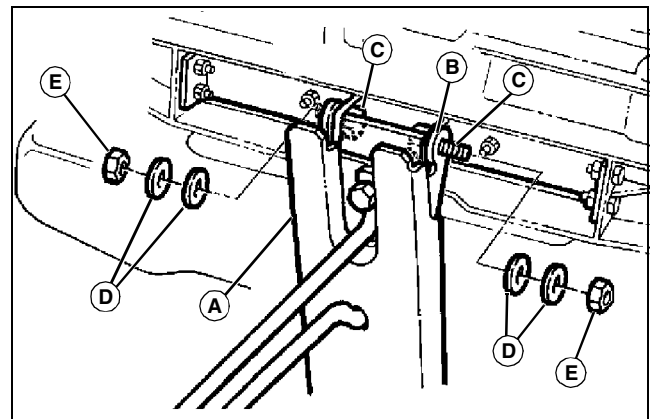

MX8875d

2. Install mounting post (A) to hopper top hinge (B).
3. Install M8x25 hex head bolts (C) from inside of hinge.

NOTE: Spring washers (D) must be installed with cup of washers facing each other. Do not over-tighten.

4. Install two spring washers (D) and M8 lock nut (E) on each hexhead bolt and tighten.
5. Fully raise and lower hopper top several times.
6. Tighten or loosen hardware to adjust hopper top hinge tightness.



Suggest:

If the above button click is invalid.

Please download this document

first, and then click the above link

to download the complete manual.

Thank you so much for reading

ASSEMBLY

Assemble Stop Bracket to Mounting Post Bracket

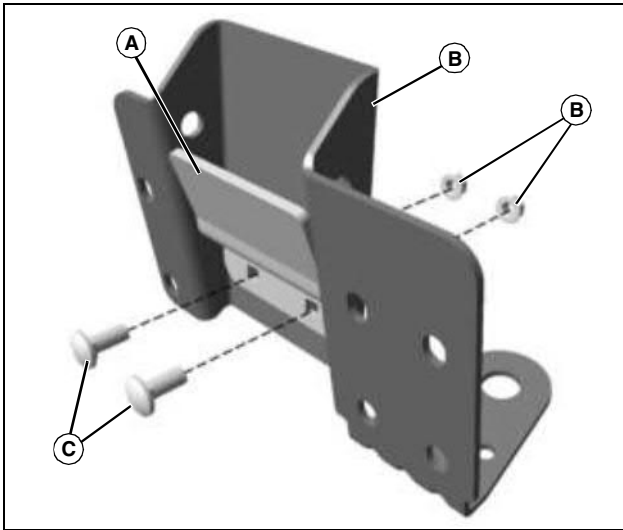

MX44775

1. Position stop bracket (A) inside of mounting post bracket (B), aligning square mounting holes in stop bracket with the two slotted holes in the mounting post bracket. Secure with two M8x20 carriage bolts (C), installed from the inside out, and two M8 flange nuts (D). Do not fully tighten until mounting post is installed, to adjust properly for crosspin alignment.

Assemble Mounting Post Bracket to Machine

NOTE: Allow engine to cool before beginning kit installation. Some components are in proximity to muffler.

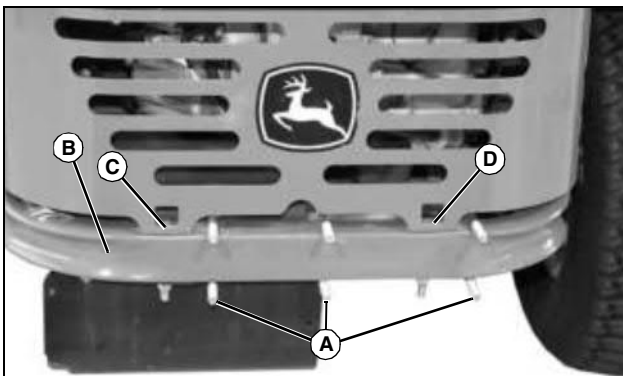

MX39862

1. Install three U-bolts (A) around machine frame (B) from the front. Position left side U-bolt to the inside of engine shield mount (C), and the right side U-bolt to the outside of engine shield mount (D).

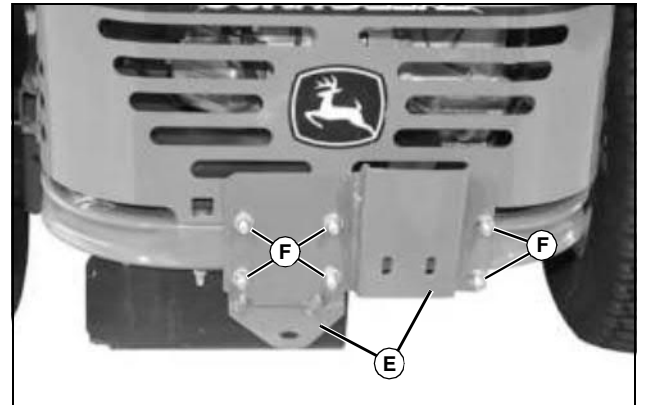

MX39861

2. Assemble the rear hitch plate (E) onto the three U-bolts and secure with six 3/8 in. flange locknuts (F). Do not fully tighten hardware at this time.

Install Quick-Attach Pins

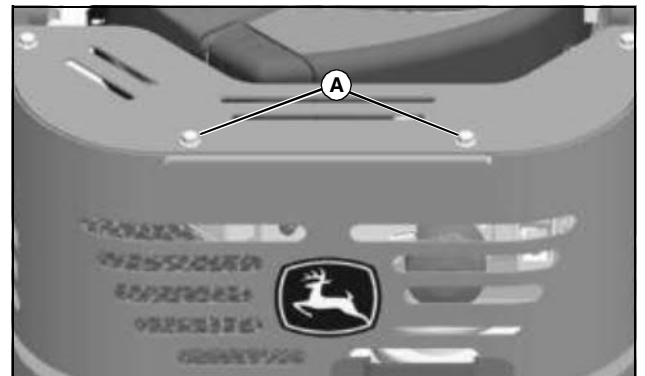

MX37840

1. Remove and discard the two M8x20 flange head bolts (A) at the top rear of the engine cover, and replace with two M8 quick-attach pins from the bag of parts. Tighten hardware.

Install High Lift Blades (42 / 48 in. Cut and Throw)

1. Park machine safely. (See Parking Safely in the SAFETY section.)
2. Raise mower deck to gain access to mower blades. If necessary, remove mower deck.
3. Block mower blade being removed with a piece of wood to prevent it from spinning.
4. Remove standard mower blade:

<https://www.ebooklibonline.com>

Hello dear friend!

Thank you very much for reading.

Enter the link into your browser.

The full manual is available for immediate download.

<https://www.ebooklibonline.com>