

MDG0002A

# **TRACTORS 360 - 370 - 375 KOMPAKT SERVICE MANUAL**

<b>SECTIONS</b>	
<b>GENERAL GUIDELINES</b> .....	<b>00</b>
<b>ENGINE</b> .....	<b>10</b>
<b>CLUTCH</b> .....	<b>18</b>
<b>TRANSMISSIONS</b> .....	<b>21</b>
<b>DRIVE LINES</b> .....	<b>23</b>
<b>FRONT MECHANICAL TRANSMISSION</b> .....	<b>25</b>
<b>REAR MECHANICAL TRANSMISSION</b> .....	<b>27</b>
<b>POWER TAKE-OFF</b> .....	<b>31</b>
<b>BRAKES</b> .....	<b>33</b>
<b>HYDRAULIC SYSTEMS</b> .....	<b>35</b>
<b>STEERING</b> .....	<b>41</b>
<b>AXLE AND WHEELS</b> .....	<b>44</b>
<b>CAB AIR CONDITIONING SYSTEM</b> .....	<b>50</b>
<b>ELECTRICAL SYSTEM</b> .....	<b>55</b>
<b>PLATFORM, CAB, BODYWORK</b> .....	<b>90</b>

**T E C H N I C A L   S U P P O R T**

## SAFETY REGULATIONS

### PAY ATTENTION TO THIS SYMBOL

*This warning symbol points out important messages concerning your safety.*

*Carefully read the following safety regulations and observe advised precautions in order to avoid potential hazards and safeguard your health and safety. In this manual the symbol is accompanied by the following key-words:*

**CAUTION** - Warnings concerning unsuitable repair operations that may jeopardise the safety of Service personnel.

**DANGER** - It gives specific warning about potential dangers for personal safety of the operator or other persons directly or indirectly involved in the operation.

### ACCIDENT PREVENTION

Most accidents or injuries that occur in workshops are the result of non-observance of simple and fundamental safety regulations. For this reason, IN MOST CASES THESE ACCIDENTS CAN BE AVOIDED by foreseeing possible causes and consequently acting with the necessary caution and care. Accidents may occur with all types of vehicle, regardless of how well it was designed and built.

A careful and judicious service technician is the best guarantee against accidents.

Precise observance of the most basic safety rule is normally sufficient to avoid many serious accidents.

**DANGER.** Never carry out any cleaning, lubrication or maintenance operations when the engine is running.

## SAFETY REGULATIONS

### GENERAL

- Carefully follow specified repair and maintenance procedures.
- Do not wear rings, wristwatches, jewellery, unbuttoned or loose articles of clothing such as: ties, torn clothing, scarves, open jackets or shirts with open zips that may remain entangled in moving parts. It is advised to wear approved safety clothing, e.g.: non-slip footwear, gloves, safety goggles, helmets, etc.

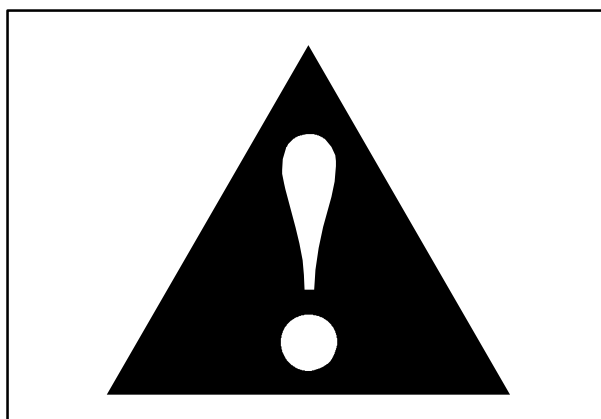

1

- Do not carry out repair operations with someone sitting in the driver's seat, unless the person is a trained technician who is assisting with the operation in question.
- Do not operate the vehicle or use any of the implements from different positions, other than the driver's seat.
- Do not carry out operations on the vehicle with the engine running, unless specifically indicated.
- Stop the engine and check that the hydraulic circuits are pressure-free before removing caps, covers, valves, etc.
- All repair and maintenance operations must be carried out using extreme care and attention.
- Service stairs and platforms used in a workshop or in the field should be built in compliance with the safety rules in force.
- Disconnect the batteries and label all controls to indicate that the vehicle is being serviced. Any parts that are to be raised must be locked in position.
- Do not check or fill fuel tanks, accumulator batteries, nor use starting liquid when smoking or near naked flames, as these fluids are inflammable.
- Brakes are inoperative when manually released for repair or maintenance purposes. Use blocks or similar devices to control the machine in these conditions.
- The fuel nozzle should always be in contact with the filling aperture. Maintain this position until filling operations are completed in order to avoid possible sparks caused by the accumulation of static electricity.

- Only use specified towing points for towing the tractor. Connect parts carefully. Make sure that all pins and/or locks are secured in position before applying traction. Never remain near the towing bars, cables or chains that are operating under load.
- Transport vehicles that cannot be driven using a trailer or a low-loading platform trolley, if available.
- When loading or unloading the vehicle from the trailer (or other means of transport), select a flat area capable of sustaining the trailer or truck wheels. Firmly secure the tractor to the truck or trailer and lock the wheels in the position used by the carrier.
- Electric heaters, battery-chargers and similar equipment must only be powered by auxiliary power supplies with efficient ground insulation to avoid electrical shock hazards.
- Always use suitable hoisting or lifting devices when raising or moving heavy parts.
- Take extra care if bystanders are present.
- Never pour petrol or diesel oil into open, wide or low containers.
- Never use petrol, diesel oil or other inflammable liquids as cleaning agents. Use non-inflammable, non toxic commercially available solvents.
- Wear safety goggles with side guards when cleaning parts with compressed air.
- Limit the air pressure to a maximum of 30.45 psi (2.1 bar), according to local regulations.
- Do not run the engine in confined spaces without suitable ventilation.
- Do not smoke, use naked flames, or cause sparks in the area when fuel filling or handling highly inflammable liquids.
- Never use naked flames for lighting when working on the machine or checking for "leaks".
- All movements must be carried out carefully when working under, on or near the vehicle. Wear protective equipment: helmets, goggles and special footwear.
- When carrying out checks with the engine running, request the assistance of an operator in the driver's seat. The operator must maintain visual contact with the service technician at all times.
- If operating outside the workshop, position the vehicle on a flat surface and lock in position. If working on a slope, lock the vehicle in position. Move to a flat area as soon as is safely possible.
- Damaged or bent chains or cables are unreliable. Do not use them for lifting or towing. Always use suitable protective gloves when handling chains or cables.
- Chains should always be safely secured. Make sure that the hitch-up point is capable of sustaining the load in question. Keep the area near the hitch-up point, chains or cables free of all bystanders.
- Maintenance and repair operations must be carried out in a CLEAN and DRY area. Eliminate any water or oil spillage immediately.
- Do not create piles of oil or grease-soaked rags as they represent a serious fire hazard. Always place them into a metal container. Before starting the tractor or its attachments, check, adjust and block the operator's seat. Also check that there are no persons within the tractor or implement range of action.
- Do not keep into your pockets any object which might fall unobserved into the Vehicle's inner compartments.
- In the presence of protruding metal parts, use protective goggles or goggles with side guards, helmets, special footwear and gloves.
- When welding, use protective safety devices: tinted safety goggles, helmets, special overalls, gloves and footwear. All persons present in the area where welding is taking place must wear tinted goggles. NEVER LOOK DIRECTLY AT THE WELDING ARC WITHOUT SUITABLE EYE PROTECTION.
- Metal cables tend to fray with repeated use. Always use suitable protective devices (gloves, goggles, etc.) when handling cables.
- Handle all parts carefully. Do not put your hands or fingers between moving parts. Always wear suitable safety clothing - safety goggles, gloves and shoes.

**<https://www.ebooklibonline.com>**

Hello dear friend!

Thank you very much for reading.

Enter the link into your browser.

The full manual is available for immediate download.

**<https://www.ebooklibonline.com>**

## START UP

- Never run the engine in confined spaces that are not equipped with adequate ventilation for exhaust gas extraction.
- Never bring your head, body, arms, legs, feet, hands, fingers near fans or rotating belts.

## ENGINE

- Always loosen the radiator cap slowly before removing it to allow any remaining pressure in the system to be discharged. Filling up with coolant should only be carried out with the engine stopped or idling (if hot).
- Never fill up with fuel when the engine is running, especially if hot, in order to prevent the outbreak of fire as a result of fuel spillage.
- Never check or adjust fan belt tension when the engine is running.  
Never adjust the fuel injection pump when the vehicle is moving.
- Never lubricate the vehicle when the engine is running.

## ELECTRICAL SYSTEMS

- If it is necessary to use auxiliary batteries, remember that both ends of the cables must be connected as follows: (+) with (+) and (-) with (-). Avoid short-circuiting the terminals. **GAS RELEASED FROM BATTERIES IS HIGHLY INFLAMMABLE.** During charging, leave the battery compartment uncovered to improve ventilation. Never check the battery charge using "jumpers" (metal objects placed on the terminals). Avoid sparks or flames near the battery zone. Do no smoke to prevent explosion hazards.
- Before servicing operations, check for fuel or current leaks. Eliminate any eventual leaks before proceeding with work.
- Never charge batteries in confined spaces. Make sure that there is adequate ventilation in order to prevent accidental explosion hazards as a result of the accumulation of gases released during charging operations.
- Always disconnect the batteries before performing any kind of servicing on the electrical system.

## HYDRAULIC SYSTEMS

- A liquid leaking from a tiny hole may be almost invisible but, at the same time, be powerful

enough to penetrate the skin; therefore, NEVER USE HANDS TO CHECK FOR LEAKS. Use a piece of cardboard or wood for this purpose. If any liquid penetrates skin tissue, call for medical aid immediately. Failure to treat this condition with correct medical procedure may result in serious infection or dermatosis.

- In order to check the pressure in the system use suitable instruments.

## WHEELS AND TYRES

- Check that the tyres are correctly inflated at the pressure specified by the manufacturer. Periodically check for possible damage to the rims and tyres.
- Stand away from (at the side of) the tyre when checking inflation pressure.
- Only check pressure when the tractor is unloaded and the tyres are cold, to avoid incorrect readings as a result of over-pressure. Do not reuse parts of recovered wheels as improper welding, brazing or heating may weaken the wheel and make it fail.
- Never cut or weld a rim mounted with an inflated tyre.
- To remove the wheels, lock both the front and rear vehicle wheels. After having raised the vehicle, position supports underneath, according to regulations in force.
- Deflate the tyre before removing any object caught in the tyre tread.
- Never inflate tyres using inflammable gases; as this may result in explosions and injury to bystanders.

## REMOVAL AND INSTALLATION

- Lift and handle all heavy parts using suitable hoisting equipment. Ensure that parts are supported by appropriate slings and hooks. Use lifting eyes provided to this purpose. Extra care should be taken if persons are present near the load to be lifted.
- Handle all parts carefully. Do not put your hands or fingers between parts. Wear suitable safety clothing - safety goggles, gloves and shoes.
- Avoid twisting chains or metal cables. Always wear safety gloves when handling cables or chains.

**SECTION 10 - ENGINE****Chapter 1 - Engine****CONTENT**

<b>Section</b>	<b>Description</b>	<b>Page</b>
<b>10 000</b>	General specifications .....	2
	Main data .....	5
	Torque settings .....	20
	Tools .....	21
	Sections .....	23
	Lubrication and cooling system diagrams .....	25
	Troubleshooting .....	27
<b>10 001 10</b>	Engine. Removal - Installation .....	31
<b>10 001 30</b>	Compression test .....	33
<b>10 001 54</b>	Engine. Disassembly - Assembly .....	34
<b>10 101 53</b>	Valve guides. Replacement .....	69
<b>10 101 60</b>	Injector sleeve. Replacement .....	72
<b>10 102 70</b>	Front engine oil seal. Removal - Installation .....	74
<b>10 106 12</b>	Valve rocker arm clearance adjustment .....	76
<b>10 218 30</b>	Engine injector. Removal - Installation .....	78
<b>10 246 14</b>	Bosch injection pump. Removal-Installation timing and air bleeding check .....	80
<b>10 254 44</b>	Exhaust pipe. Removal-Refitting .....	86
<b>10 402 11</b>	Coolant pump. Removal-Refitting with radiator removed .....	87
<b>10 402 28</b>	Coolant pump. Overhaul .....	88
<b>10 402 30</b>	Thermostat valve. Removal-Refitting .....	89
<b>10 406 10</b>	Radiator. Removal - Installation .....	91

<b>GENERAL SPECIFICATIONS</b>	
Engine, technical type:	
- Mod. 360 - type 8035.05C.615/619/919 (BOSCH pump)	See data on page 6-7
- Mod. 370 - type 8035.25R.615/619/919 (BOSCH pump)	See data on page 8-9
- Mod. 375 - type 8035.25.615/619/919 (BOSCH pump)	See data on page 10-11
Cycle .....	diesel, 4-stroke
Fuel injection .....	Direct
Number of cylinders in line .....	3
Cylinder liners .....	in cylinder block
Diameter of pistons	
- Mod. 360 .....	4.0944 in. (104 mm)
- Mod. 370 .....	4.0944 in. (104 mm)
- Mod. 375 .....	4.0944 in. (104 mm)
Piston stroke .....	4.5275 in. (115 mm)
Total displacement:	
- Mod. 360 .....	2931 cm <sup>3</sup>
- Mod. 370 .....	2931 cm <sup>3</sup>
- Mod. 375 .....	2931 cm <sup>3</sup>
Compression ratio mod. 360 .....	17:1 normally aspirated
Compression ratio for Mod. 370 and 375 .....	16.5:1 turbocharged
Maximum power:	
- Mod. 360 .....	43.5 kW (59 Hp)
- Mod. 370 .....	53 kW (72 HP)
- Mod. 375 .....	55.5 kW (76 Hp)
Maximum power speed .....	2300 rpm
Maximum torque speed for Mod. 360 .....	1400 rev/min
Maximum torque speed for Mod. 370 .....	1400 rev/min
Maximum torque speed for Mod. 375 .....	1400 rev/min
Number of main bearings .....	4
Sump .....	structural, cast iron

(continued)

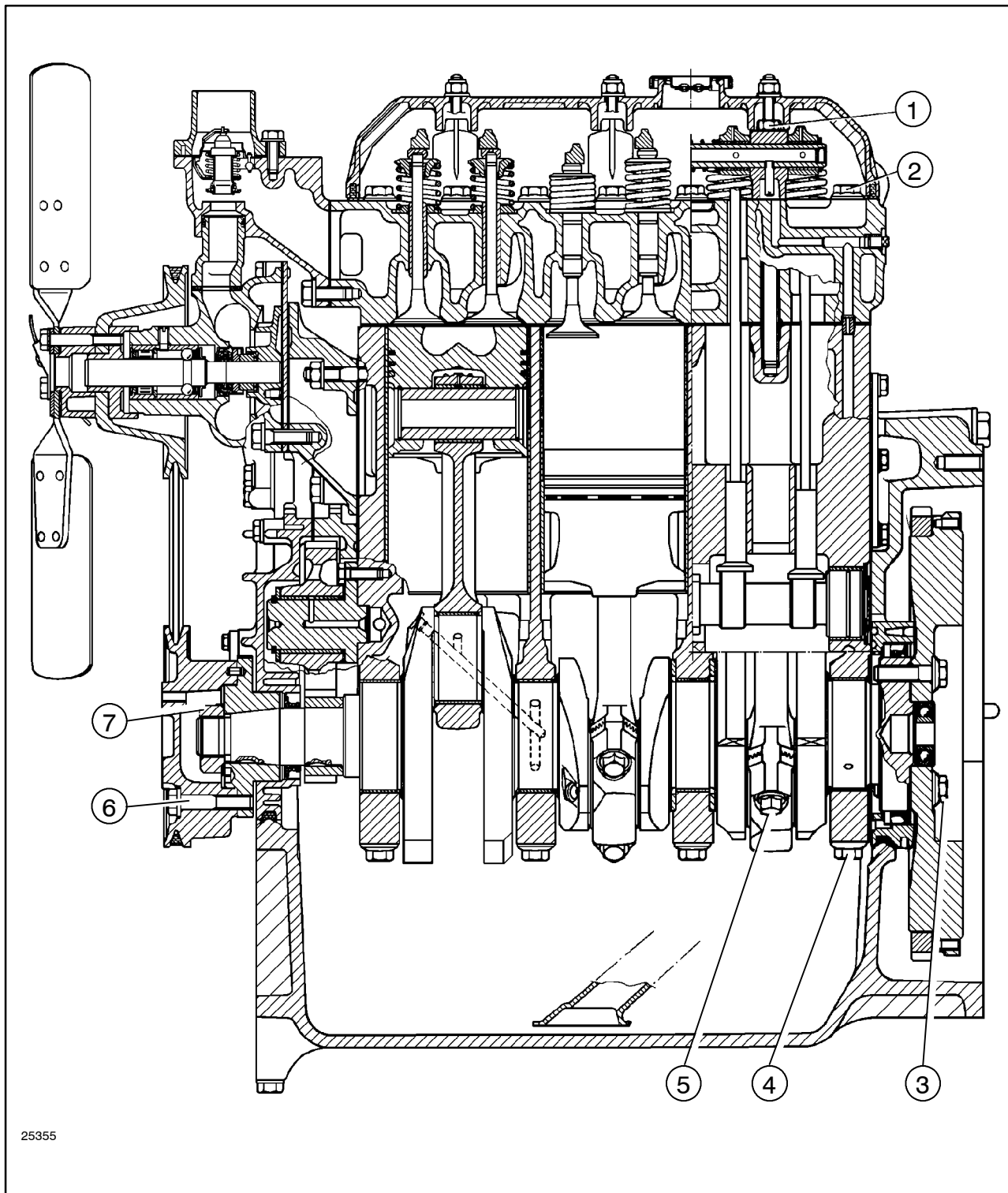

25355

Longitudinal section of engine (mod. 360).

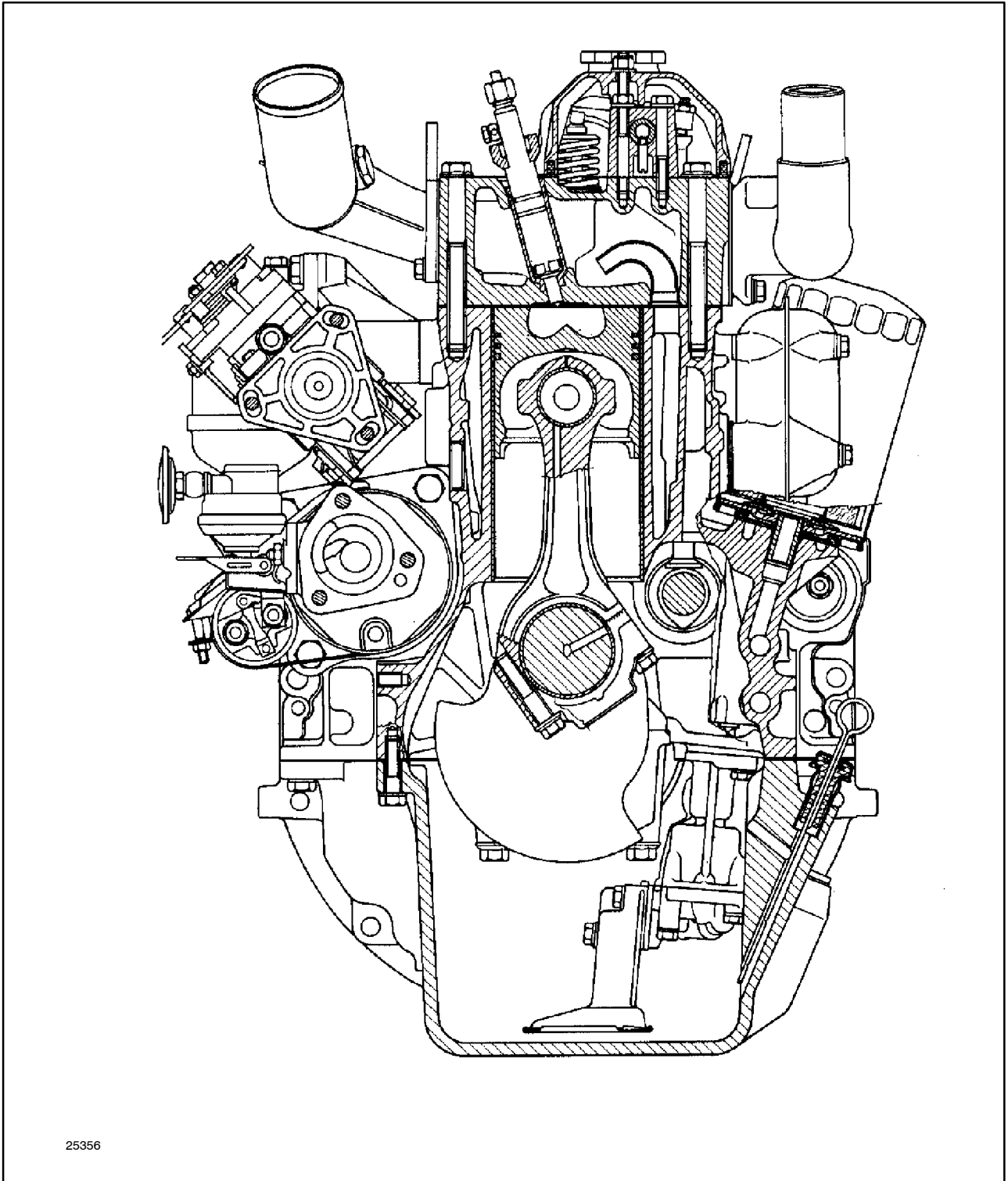

Cross-section of engine (mod. 360).

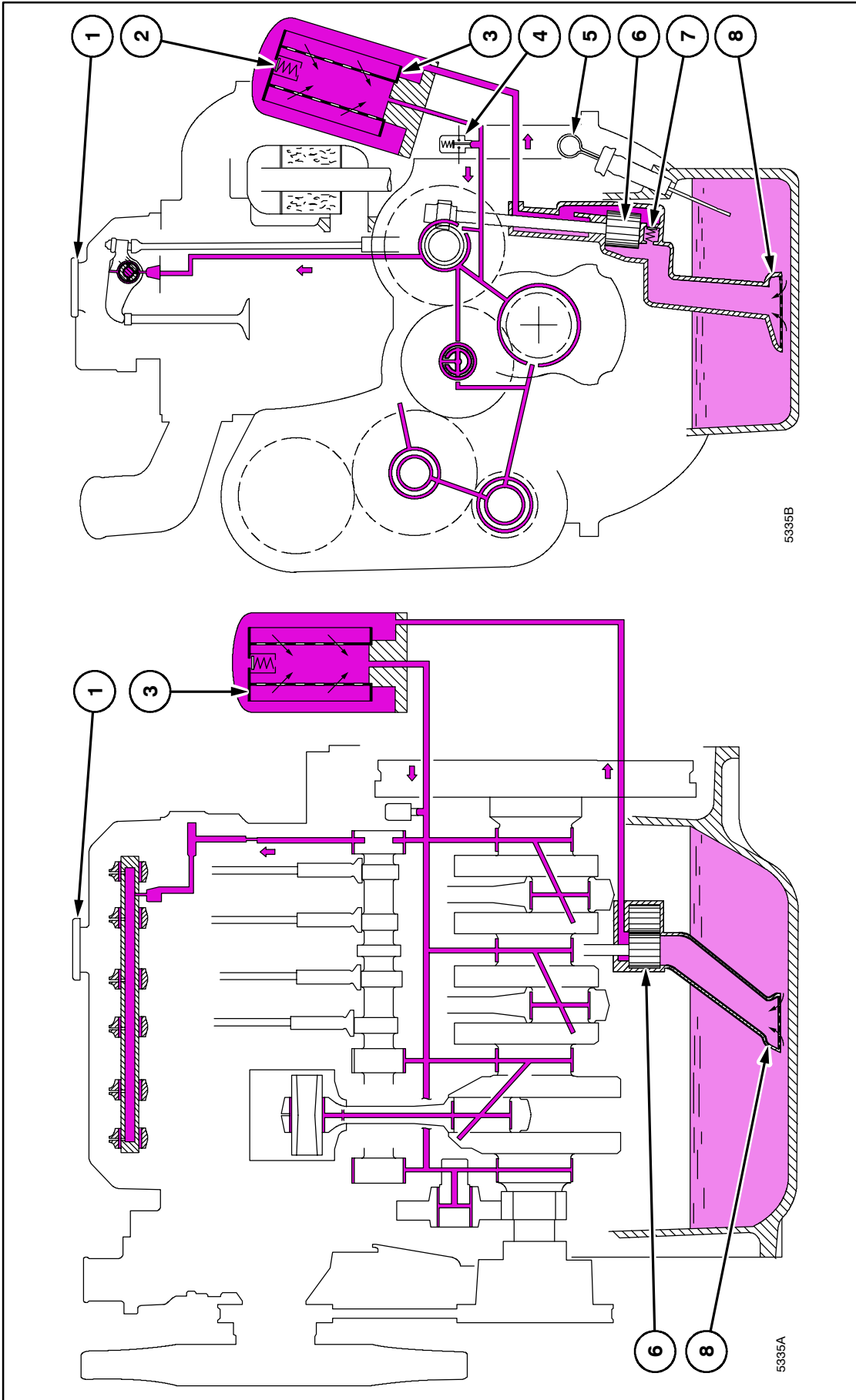

**Engine lubrication system diagram**

1. Oil filler cap - 2. Filter safety valve (opens when oil pressure at filter inlet exceeds the outlet pressure by 1.5-1.7 bar/cm<sup>2</sup>) - 3. Filter - 4. Engine lubrication oil low pressure indicator lamp switch (located on the dashboard) - 5. Dipstick - 6. Pump - 7. Oil pressure limiting valve - 8. Mesh filter on intake

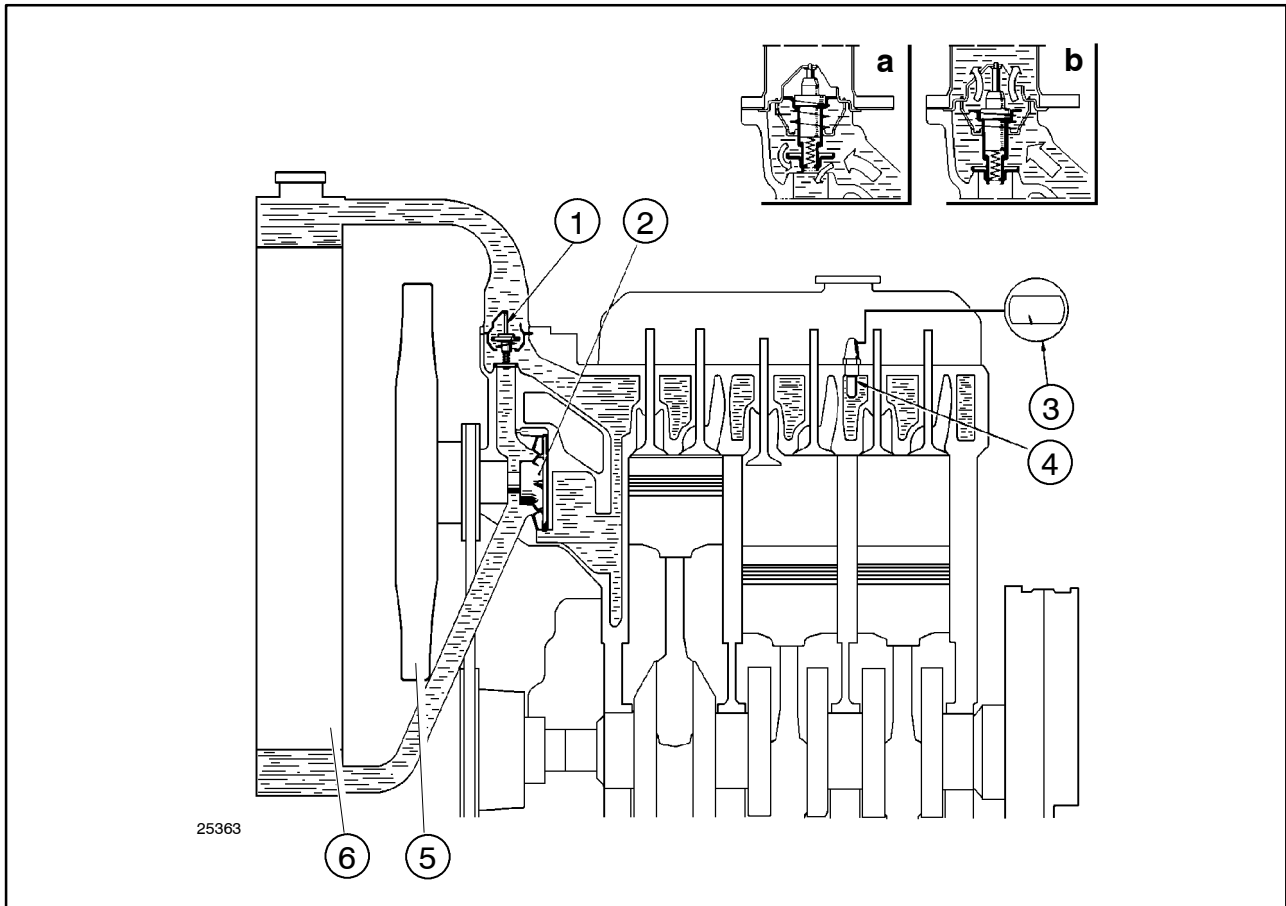

6

**Engine cooling system circuit diagram.**

- |  |   |
|--|---|
| <b>A.</b> Coolant circulation with thermostat valve closed | <b>3.</b> Electric thermometer for engine coolant temperature |
| <b>B.</b> Coolant circulation with thermostat valve open   | <b>4.</b> Temperature transmitter                             |
| <b>1.</b> Thermostat                                       | <b>5.</b> Fan   |
| <b>2.</b> Pump   | <b>6.</b> Radiator  |

**Op. 10 001 10**  
**ENGINE Removal-Installation**

**! DANGER !**

Lift and handle all heavy parts using suitable lifting equipment.

Make sure that assemblies or parts are supported by means of suitable slings and hooks. Check that no one is in the vicinity of the load to be lifted.

**! WARNING !**

Use suitable tools to align the holes. **NEVER USE FINGERS OR HANDS.**

Proceed as follows.

1. Carry out operation **18 110 10** Clutch, only removal (see Sect. 18).
2. Disconnect the clogged air filter sensor connection (1).
3. Disconnect the audible warning connection (1).

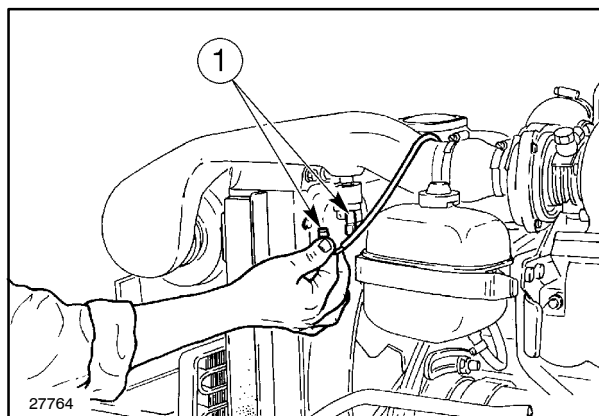

7

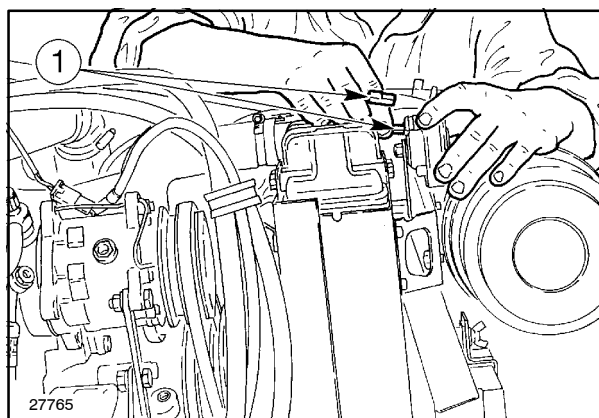

8

4. Unscrew the clamps 1, 2 and 3 and remove the inlet sleeve.

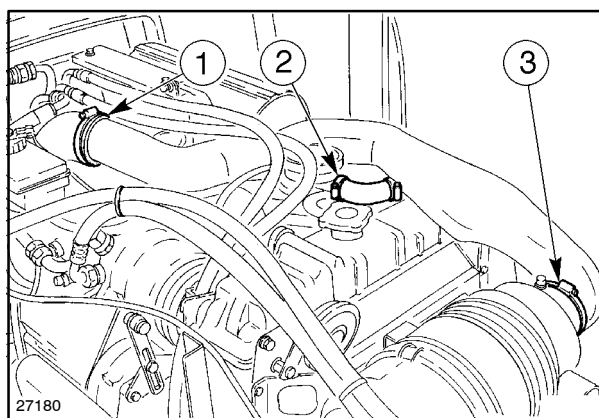

9

5. Unscrew the relative clamps and detach the upper (2) and lower sleeves on the radiator, remove the radiator bracket (1).

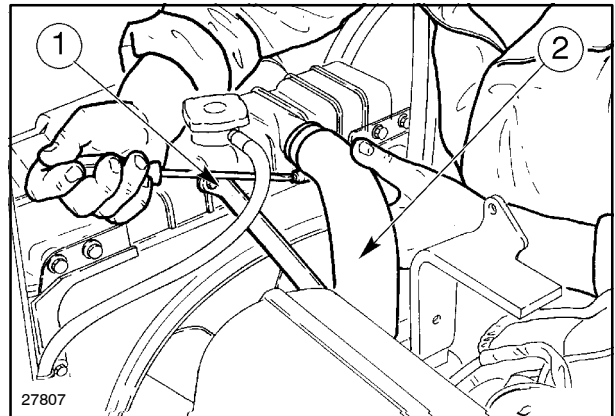

6. Position two fixed stands under the axle support and under the engine, position a chain so that the engine is balanced whilst being raised and insert two wooden blocks between the support and the axle to prevent swinging.
7. Unscrew the bolts (1) fastening the support to the front axle.
8. Detach the engine from the axle - support unit.
9. To re-fit the engine, proceed as follows.

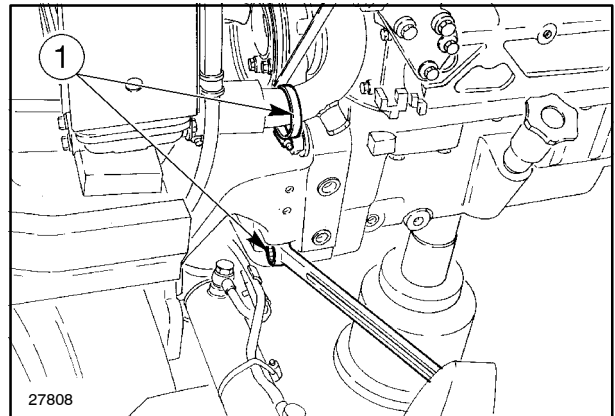

### WARNING



Use suitable tools to align the holes. NEVER USE FINGERS OR HANDS.

- Apply the torque settings listed on page 20.
- Re-fit the front axle support assembly on the engine.
- Connect and secure the upper and lower sleeves on the radiator and the connecting bracket.
- Fit and secure the inlet sleeve.
- Connect the audible warning and clogged air filter indicator connections.
- Carry out operation **18 110 10** Clutch, only installation (see Sect. 18).

**Op. 10 001 30 COMPRESSION TEST**

In case of poor engine performance, in addition to checking the fuel injection system (injection nozzles and injection pump), also test the compression on each cylinder.

**DANGER**

Do not use matches, lighters, blowtorches or any form of naked flame as a source of light when inspecting the engine due to the presence of flammable fluids and vapour.

**Degree of compression**

The compression ratio is a measure of the quantity of air drawn into the cylinder, and provides an indication of the efficiency of the sealing elements in the cylinder (piston rings and valves).

Uniform compression in all the cylinders ensures that they all perform an equal amount of work, provided that each cylinder is injected with the same quantity of fuel at the right time.

Low compression not only reduces engine performance, it also causes incomplete fuel combustion due to the lack of available combustion air.

The engine therefore gives poor performance with excessive fuel consumption and, consequently, exhaust smoke and restriction of the exhaust passages.

As the compression ratio **also varies with the temperature of the engine** (cold engines produce lower compression values than hot engines), the compression should only be tested when the engine is at normal operating temperature.

Compression should be tested using the compression test kit **380000303**, as follows:

- 1) run the engine until it reaches normal operating temperature;
- 2) switch off the engine;
- 3) disconnect the lead from the engine stop electromagnet on the injection pump in order to close the valve and block the flow of fuel to the injectors;
- 4) remove the injector from the cylinder to be tested;
- 5) turn the engine over a few times with the starter motor in order to expel any carbon residue;

6) fit the dummy injector **380000617** in place of the injector removed previously, inserting the copper sealing washer;

7) connect the compression test instrument **380000303** and take readings while turning the engine over with the starter motor.

On engines in perfect working order, with the sump oil at approx. 104 °F (40 °C) at sea level (2992 in. (760 mm) mercury) and at an engine speed of 200 to 280 rpm, the compression should be 1.75 to 1.89 psi (25.5 to 27.5 bar).

8) Test the compression on the other cylinders, repeating steps 4-5-6-7, bearing in mind that:

The minimum permissible compression on a used engine is 1.48 psi (21.6 bar).

The maximum permissible compression difference between cylinders is 0.20 psi (3 bar).

Every 100 metres above sea level corresponds to a reduction in compression by approx. 1%.

**CONSIDERATIONS:****Uniform compression**

Although high compression is important, it is more important for smooth engine running that compression is uniform in all cylinders.

Low compression readings.

If extremely low pressure readings are obtained on one cylinder it is advisable to repeat the test.

Before testing this time, pour about a spoonful of engine oil into the cylinder through the injector bore.

Turn over the engine a few times to distribute the oil evenly over the cylinder walls, and then repeat the test.

If the second test readings are significantly higher, suspect worn piston rings, out-of-round or damaged pistons or liners.

If the second test readings are not higher, the problem will be the valves.

On the other hand, if the second test reading shows only a slight improvement, the problem will be due to both the valves and the rings.

**Op. 10 001 54**  
**ENGINE Disassembly - Assembly**

**WARNING**

Handle all parts carefully. Do not put your hands or fingers between parts. Wear the prescribed safety clothing, including goggles, gloves and safety footwear.

Proceed as follows.

1. Unscrew the thermostarter union (2), the fittings fastening the pipes (1) for delivery to the pump and the injectors and detach these pipes (1).
2. Unscrew the injection pump connection pipes (2) and the bolts fastening the support (1), remove the support with the fuel filter.
3. Unscrew; the hydraulic pump pipe retaining bolts (2), bolts (1) retaining the oil filter, comprehensive of the support, to the engine and remove it.
4. Unscrew the retaining bolts and remove the hydraulic pumps of the lift (2) and services (1), the latter comprehensive of piping (3).

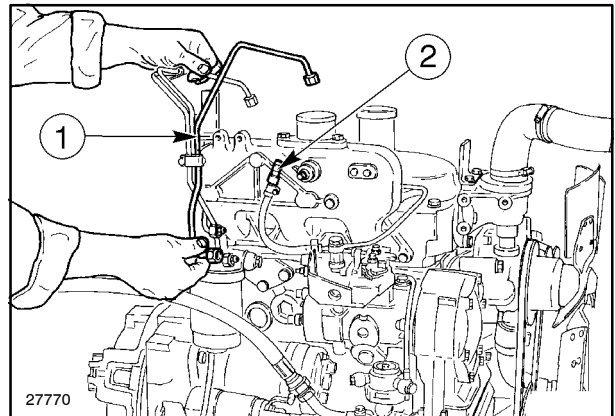

12

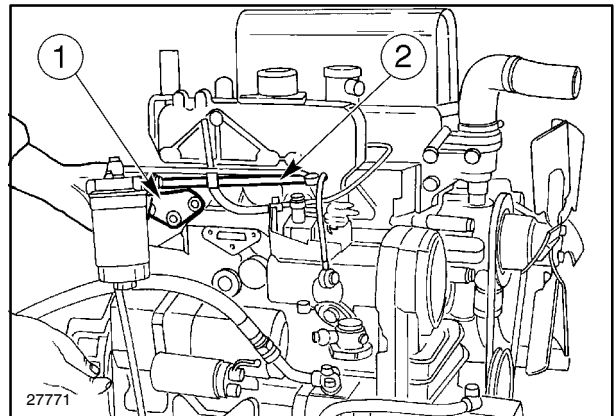

13

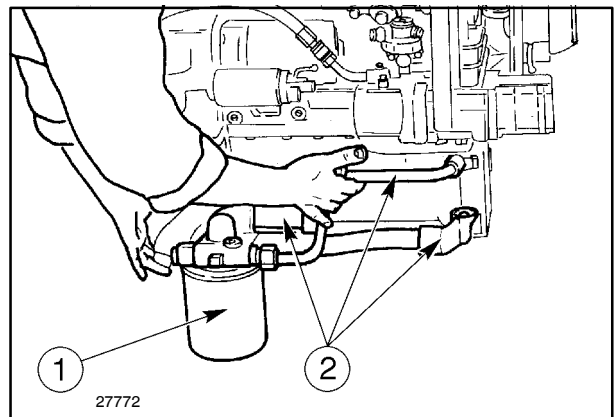

14

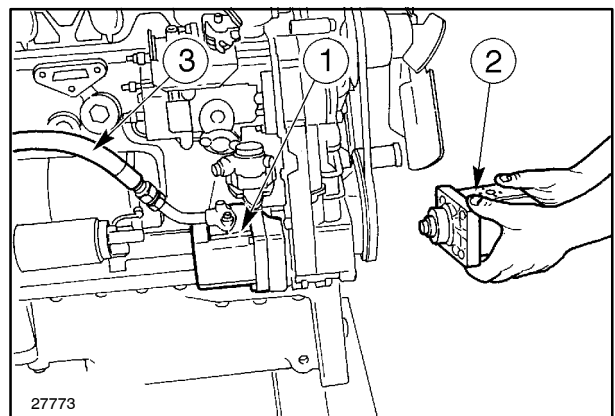

15

5. Unscrew the retaining bolts and remove the starter motor (1).

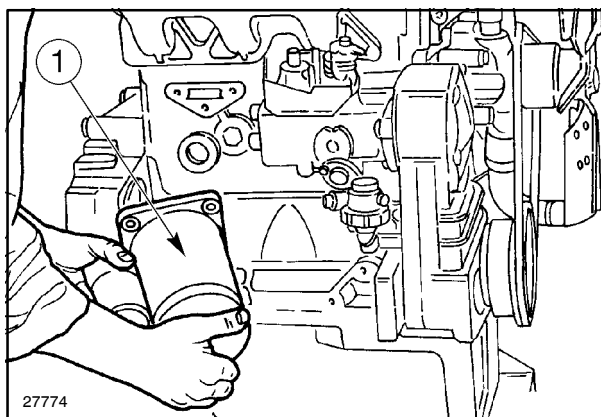

16

6. Unscrew the retaining bolts and take off the cover (3), unscrew the nut (2) fastening the injection pump (1) and remove this from the opposite side.

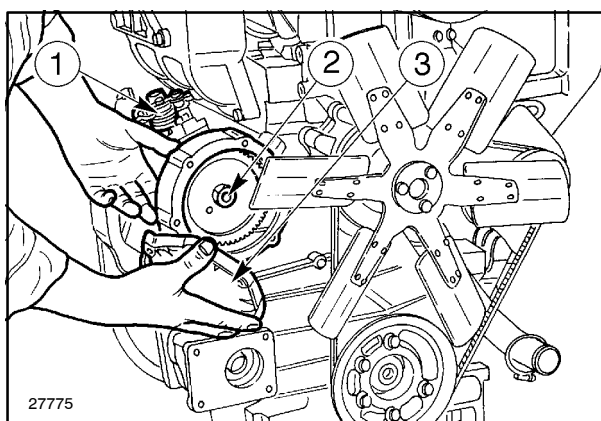

17

7. Unscrew the retaining nuts and remove the fuel pump (1).

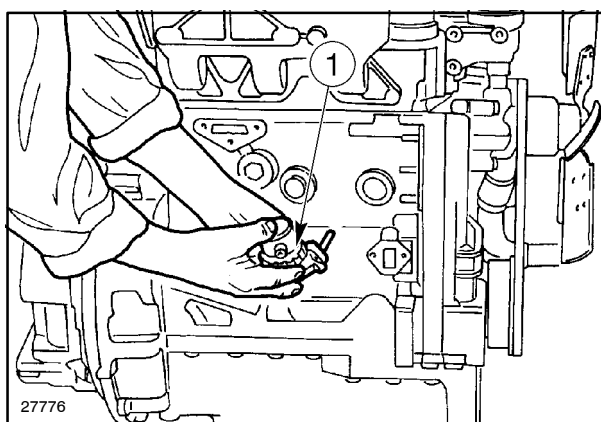

18

8. Unscrew the retaining bolts and remove the exhaust silencer (1) comprehensive of the vertical pipe. On the version with a horizontal exhaust pipe, this must be removed when removing the engine.

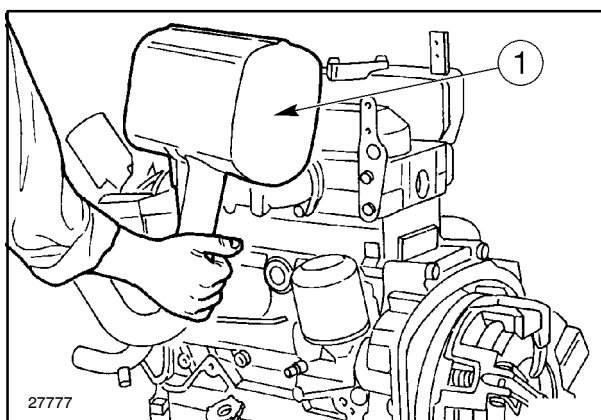

19

9. Unscrew the retaining bolts, remove the alternator (1) and recover the drive belt.
10. Unscrew the engine oil filter (2).

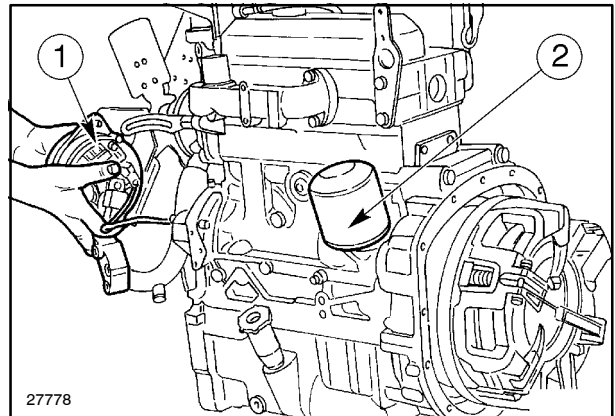

20

11. Unscrew the retaining bolts and remove the exhaust manifold (1).

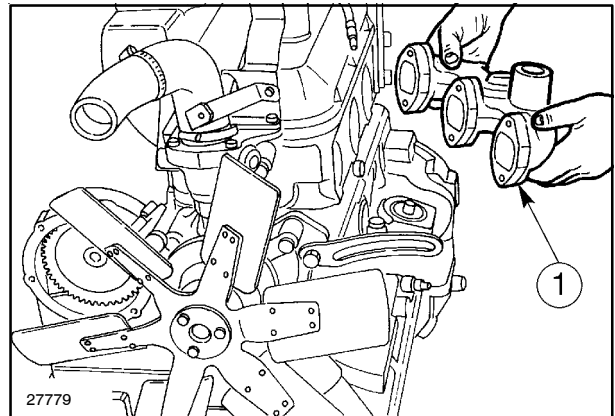

21

12. Unscrew the retaining bolts and remove the pipe (1) from the water pump.

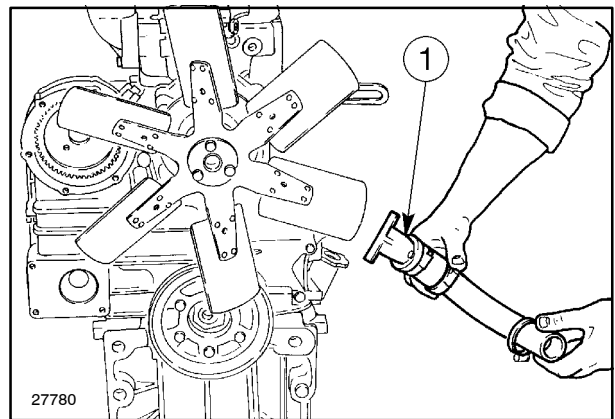

22

13. Unscrew the retaining bolts and remove the coolant pump (1) together with the fan (2).

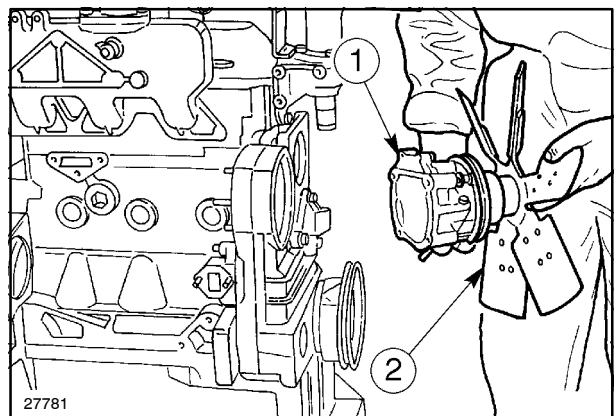

23

14. Unscrew the retaining bolts and remove the coolant pump support (1).

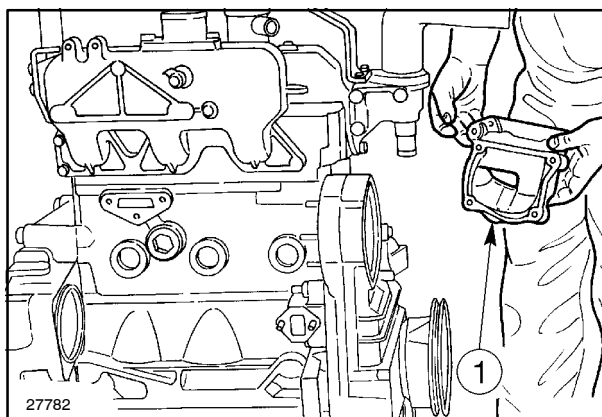

24

15. Unscrew the retaining bolts and remove the thermostat valve unit (2) together with the bracket (1).

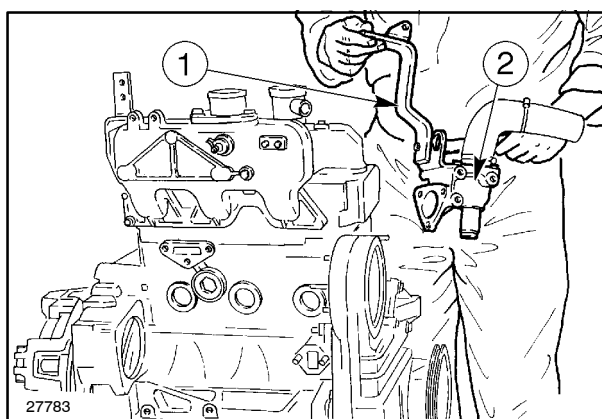

25

16. Unscrew the retaining bolts and remove the intake manifold (1).

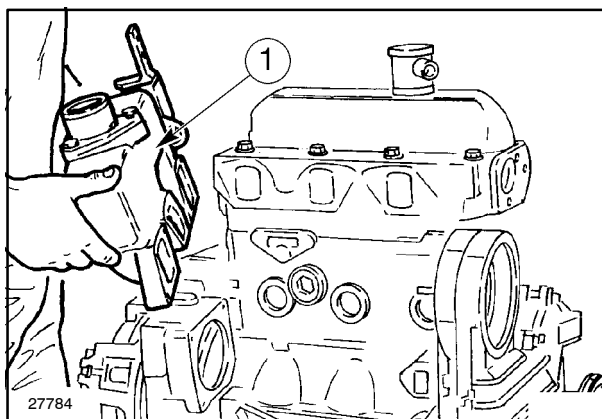

26

17. Remove the injector mounting nuts, the underlying spherical washers, then the supports and the injectors themselves.
18. Remove the retaining bolts (1), washers and seal, then remove the rocker housing cover (2) and seal.

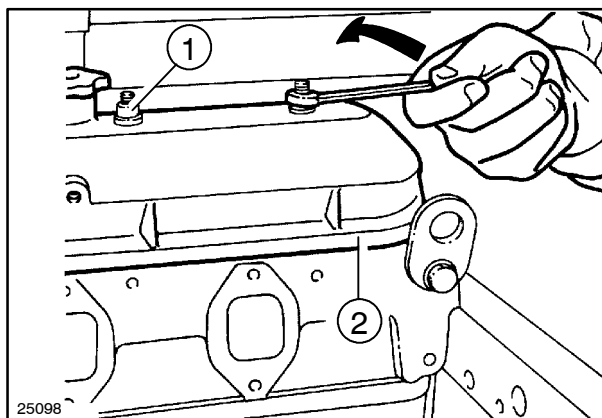

27

19. Remove the rocker shaft retaining bolts (2), then remove the entire rocker shaft assembly (1).

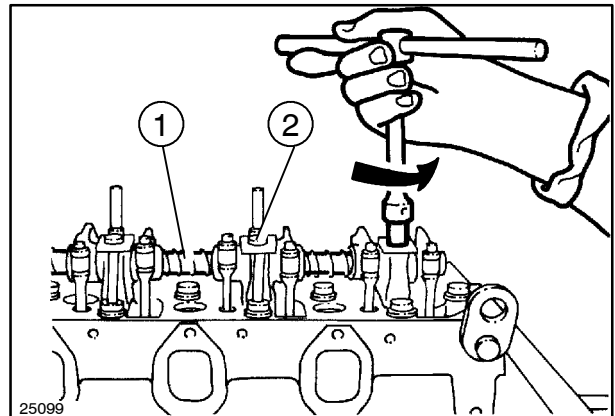

28

20. Remove the valve collets (1) and extract the pushrods (2).

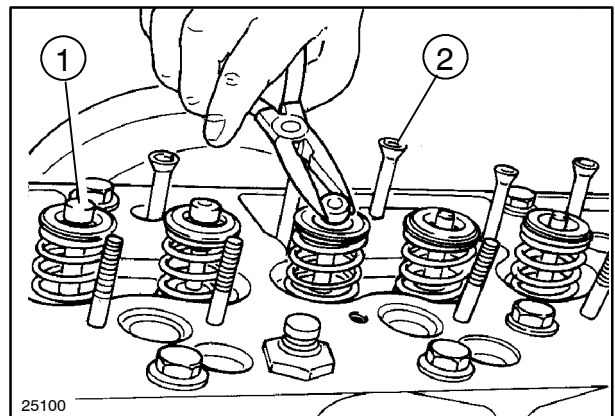

29

21. Unscrew the cylinder head bolts (1) and remove the head using a hoist and lifting hook **380000216**.
22. Remove the cylinder head gasket.

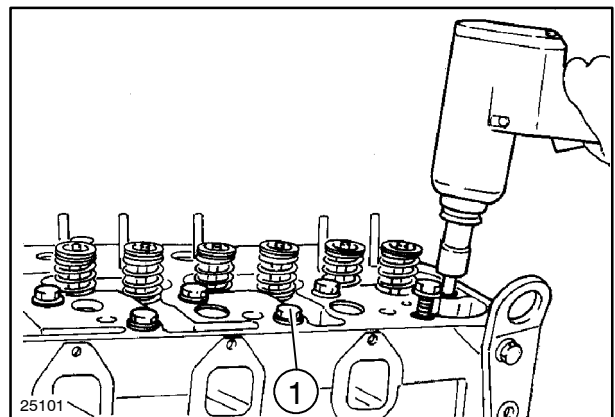

30

23. Unscrew the sump pan retaining bolts (4) and remove the sump pan using a hoist, lifting hook **380000216** and lifting chain with eyeholes.
24. Remove the half-gaskets (1) and (3) between the crankcase/sump pan and the gasket (2) between the timing gear carrier/sump pan.

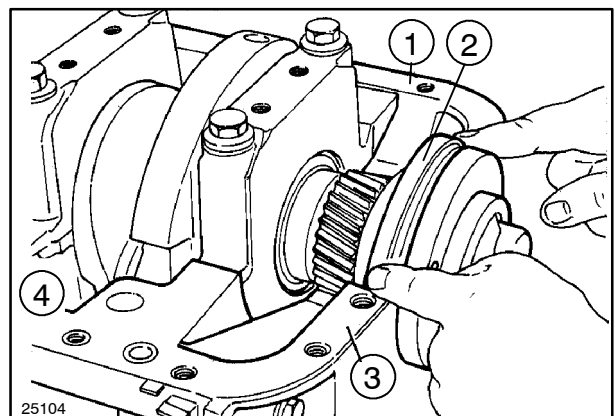

31

25. Remove the gasket (1) between the flywheel carrier and the sump pan.

**NOTE:** When relocating gaskets (1) and (2, fig. 31), apply RHODORSIL CAF1 silicone sealing compound to the mating surfaces.

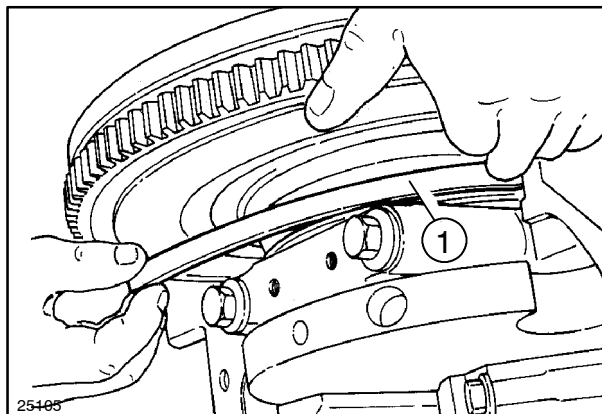

32

26. Remove the rotating counterweight oil seal O-ring (1) installed on the crankcase mating surface.

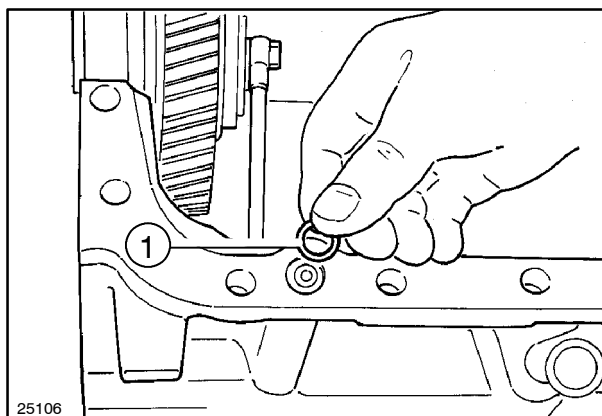

33

27. Unscrew the retaining bolts (1) and remove the complete oil pump.

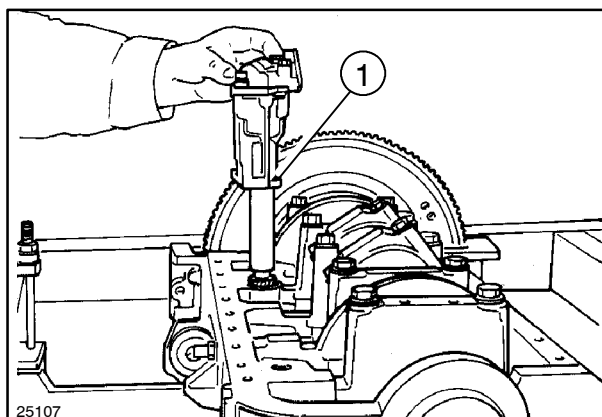

34

28. Unscrew the retaining bolts (2) and remove the fan-alternator drive pulley (1).

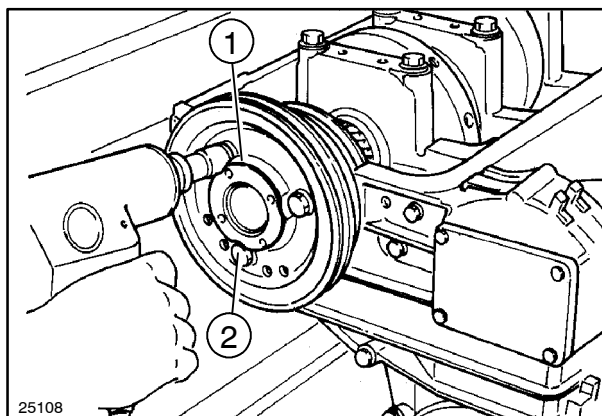

35

29. Straighten the lock tab and remove the nut (1), securing the crankshaft against rotation.

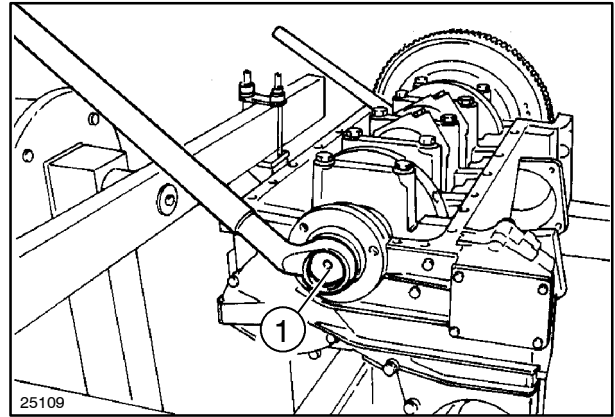

36

30. Pull the pulley hub off the crankshaft using tool **380000226** (1) and recover the Woodruff key.

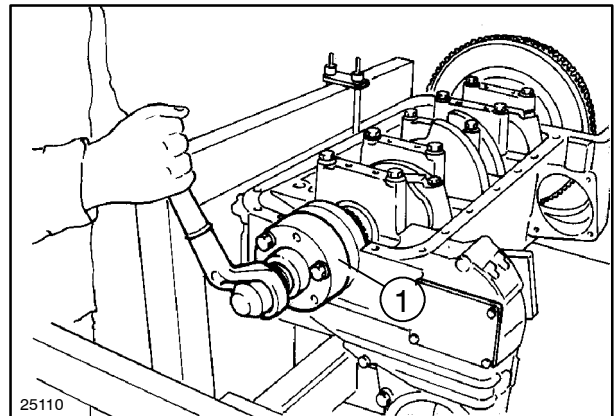

37

31. Unscrew the retaining bolts (1) and remove the timing cover and gasket.

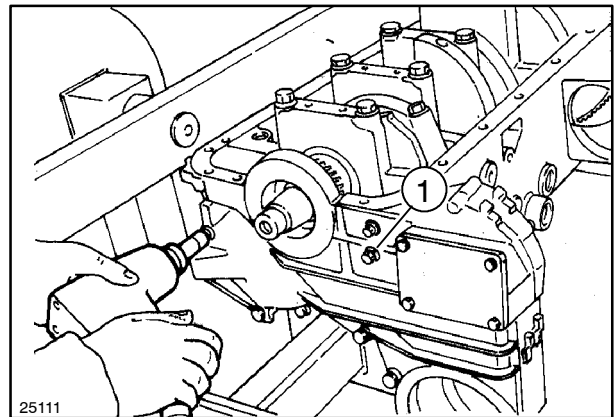

38

32. Unscrew the retaining bolts and remove the lift pump drive gear carrier (1).

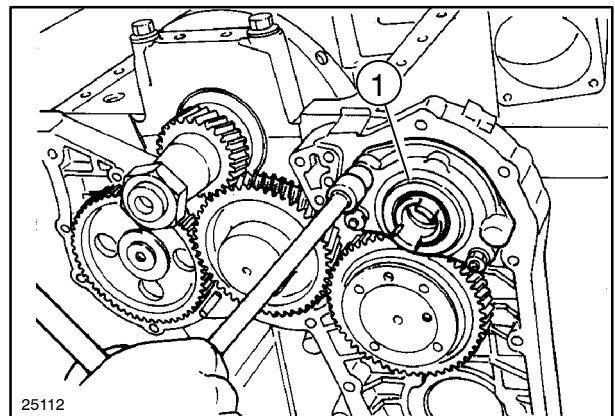

39

33. Remove the circlip (1) and recover the thrust washer and the intermediate gear (2):

**NOTE:** When refitting the intermediate gear see engine timing instructions on page 49.

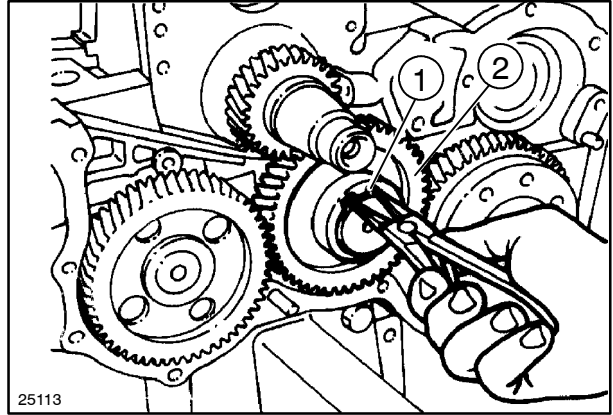

40

34. Unscrew the retaining bolts (1) and remove the intermediate gear journal.

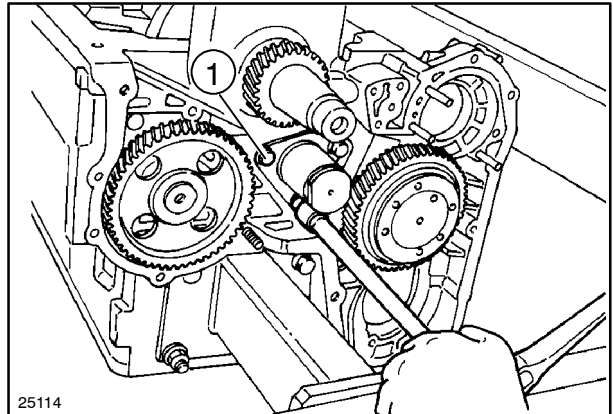

41

35. Unscrew the retaining bolts (2) and withdraw the camshaft (3) complete with the camshaft gear (1) and the end plate (4).

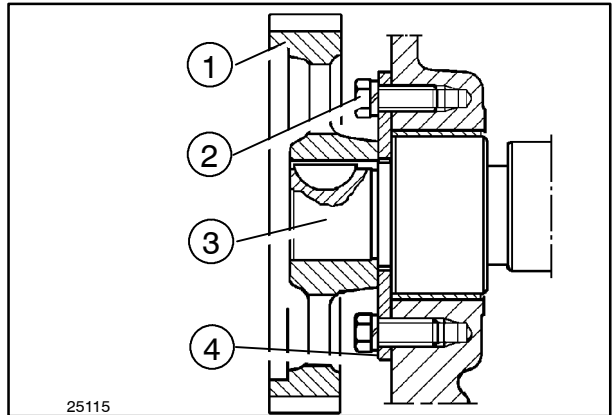

42

36. Remove the circlip (1) and the thrust washer, and withdraw the gear with fuel supply pump camshaft (2) from the opposite side.

**NOTE:** This gear transmits drive to the injection pump gear. On re-assembly, see the timing instructions on page 49.

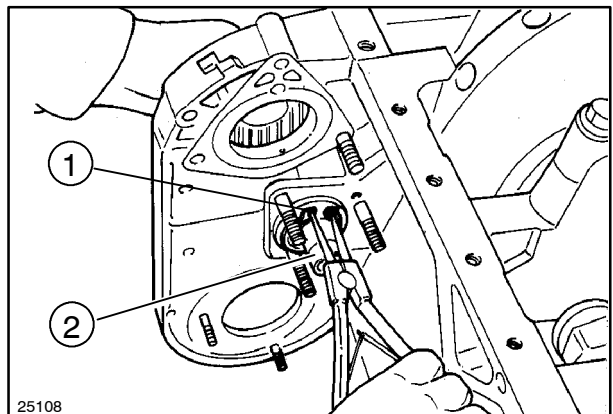

43

37. Unscrew the retaining bolts (1) and remove the timing gear case.

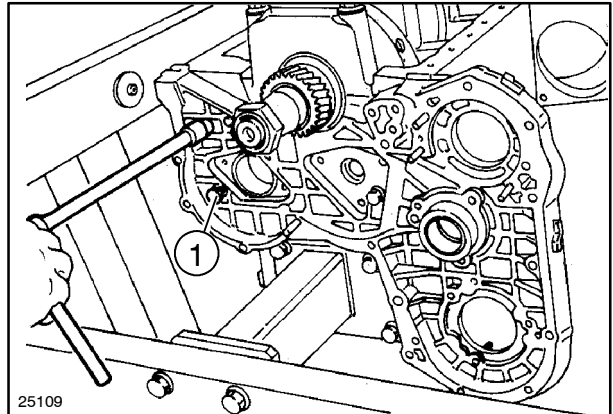

44

38. Replace the O-ring seal (1) installed in the lift pump drive shaft lubrication line.  
39. Remove the crankcase - timing gear case gasket.

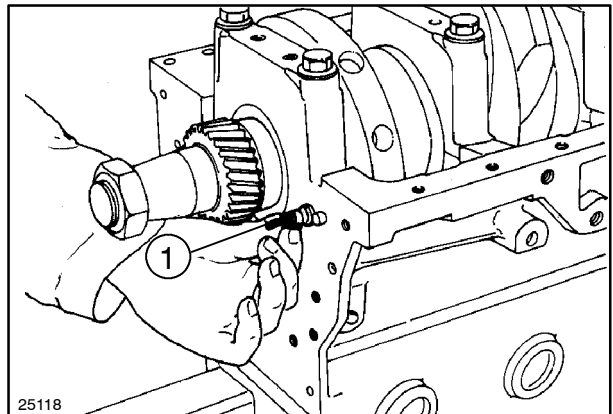

45

40. Rotate the engine through 90°, take out the retaining bolts (2) and recover the big-end caps (1) with their bearings.

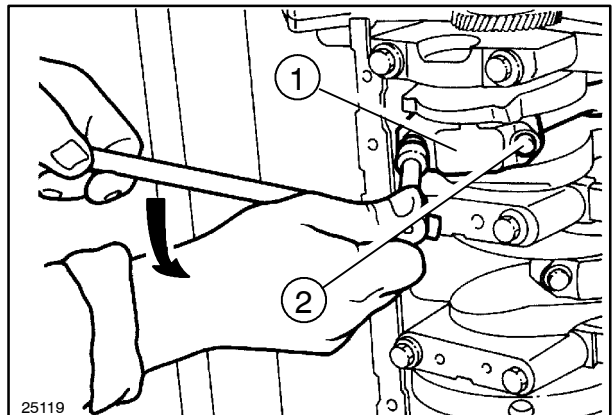

46

41. Slide the pistons (1), complete with rings, gudgeon pins and connecting rods, out of the cylinder linings.

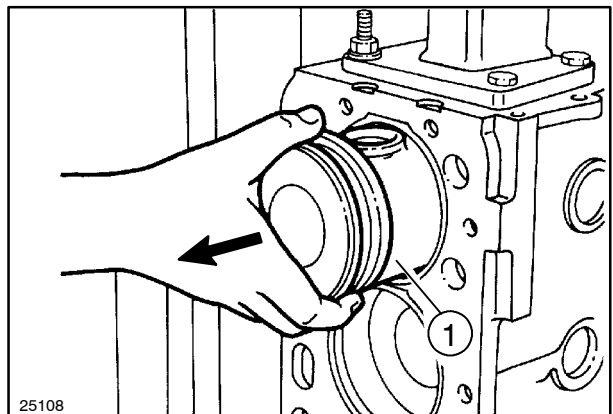

47

42. Rotate the engine on the stand through 90° back to the horizontal position. Unscrew the flywheel bolts and remove the flywheel with the aid of a hoist and hook **380000216**.
43. Unscrew the retaining bolts and remove the rear cover (1) complete with gasket.

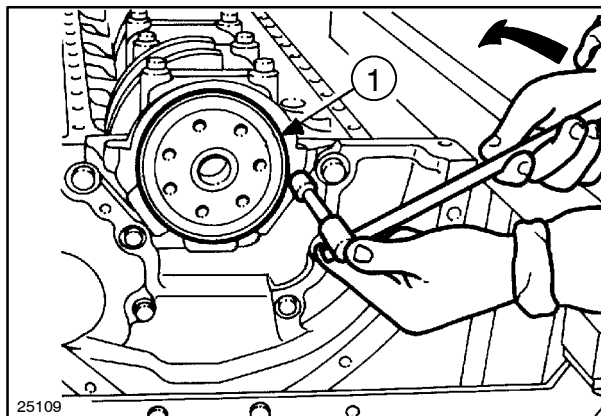

48

44. Unscrew the main bearing cap bolts (1), and remove the main bearing caps with relative bearing shells, recover the thrust washers located on the penultimate main bearing, as shown in the drawing.
45. Lift the crankshaft clear of the crankcase using a hoist and nylon sling. Recover the bearing shells, thrust washers and tappets.

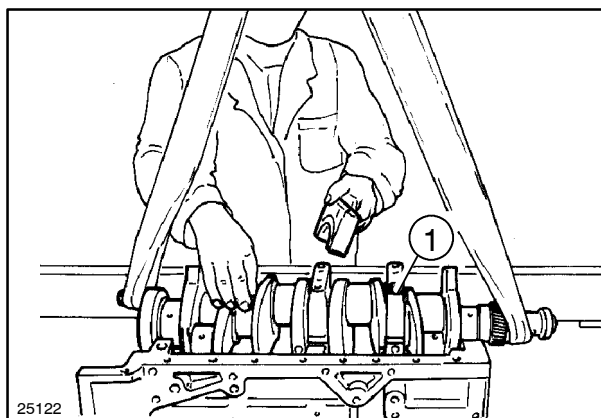

49

46. Turn the engine through 180° on rotating stand **380000301** (2). Attach the lifting chain with eye-holes to the crankcase, as shown in the figure. Slightly tension the chain with the hoist and the hook **380000216**, take out the bolts securing the crankcase to the rotating stand (2) and bracket (3) of the **380000313** series.
47. Lift the engine clear of the stand.
48. Unscrew the retaining bolts and remove the rear crankcase housing (1) and its gasket.

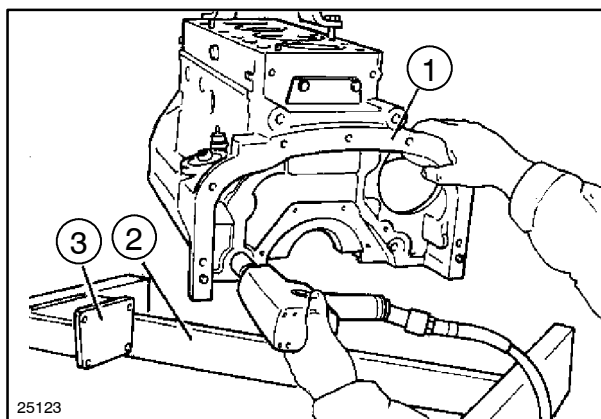

50

**GENERAL NOTES**

- After disassembling the engine, thoroughly clean the parts.
- Engine assembly operations should be carried out in reverse order to the disassembly operations described on pages 34 to 43.
- The following pages 44 to 50 concern assembly operations that require special attention in order to correctly fit parts.
- The torque settings are shown on page 20.

**REMEMBER THAT:**

- When partially or fully disassembling the engine, all seals must be replaced.
- Before inserting rotating parts and seals in seats, lubricate the parts with engine oil.
- When fitting the oil filter, lubricate the seal with engine oil.

**WARNING**

Handle all parts carefully, do not put your hands or fingers between parts and use appropriate tools to align fixing holes.

Wear the prescribed safety clothing, including goggles, gloves and safety footwear.

**MOUNTING THE TAPPETS AND DRIVE SHAFT WITH MAIN BEARING CAPS, BEARINGS AND THRUST RINGS: CHECKING AXIAL CLEARANCE OF DRIVE SHAFT (Disassembly operations 44 to 45)**

Proceed as follows:

- Install the tappets in their crankcase bores.
- Lubricate the main bearing seats with engine oil and install the half shell bearings (3).
- Insert the crankshaft semi-circular thrust washers (1), applying grease on the penultimate main bearing shims (2) to facilitate the operation.

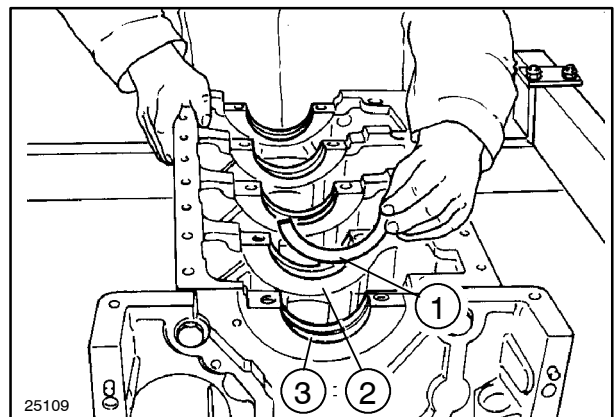

- Lubricate the upper surfaces of the main bearing shells with engine oil and lower the crankshaft (1) into position, taking care not to dislodge the semi-circular thrust washers installed previously.

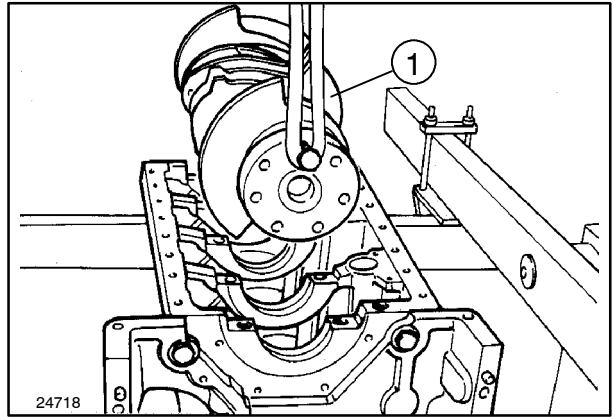

52

- Lubricate the crankshaft journals with engine oil and fit the main bearing caps (3) with the half-shells (4), fitting the top semi-circular thrust washers (2) to the penultimate bearing cap.
- Rotate the crankshaft (1) a few times to allow the parts to settle into position.
- Insert the main bearing cap bolts and screw in until the head of the bolt is up against the cap.

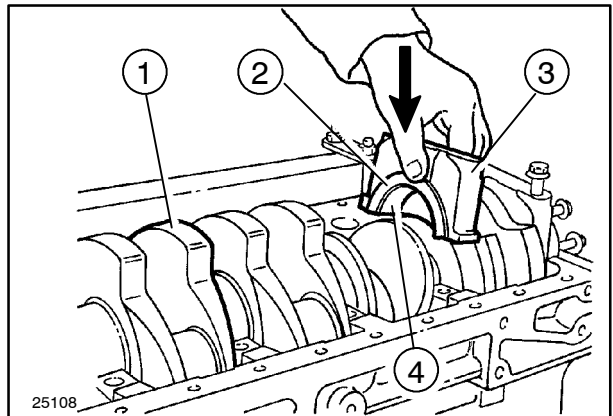

53

- Tighten all cap bolts (1) to a torque of 80 Nm (8.2 kgm).

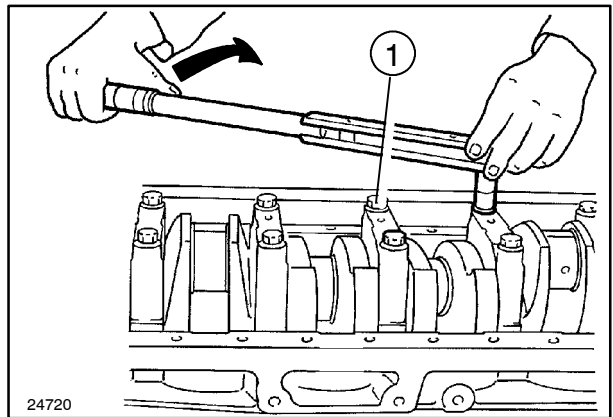

54

- Using tool **380000304** (2) tighten each bolt (1) through a further 90°.

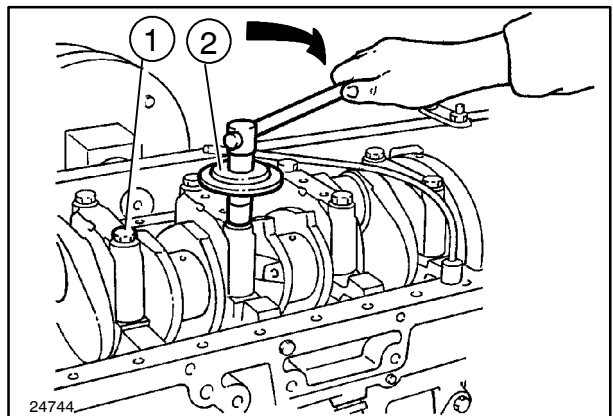

55

- Check that the crankshaft endfloat does not exceed the value specified on page 13.

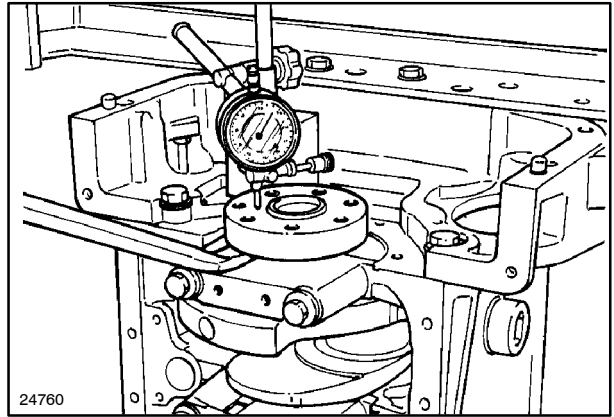

56

## MOUNTING THE REAR COVER WITH SEAL AND ENGINE FLYWHEEL

### (Disassembly operation 43)

Proceed as follows:

- Fit the rear oil seal carrier (3) with the outer seal. Tighten the retaining bolts (2) to the torque specified on page 20. Using a feeler gauge (1), check that the crankshaft flange is coaxial with the carrier.
- Fit the inner rear oil seal using tool **50139** (1) and hand grip.
- Fit the flywheel and tighten the retaining bolts (1) to a torque of 40 Nm (4.1 kgm).

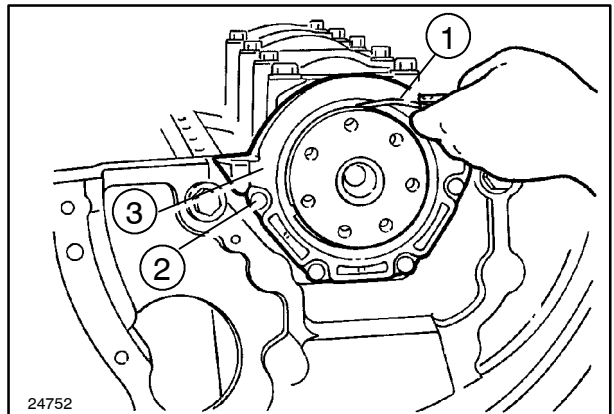

57

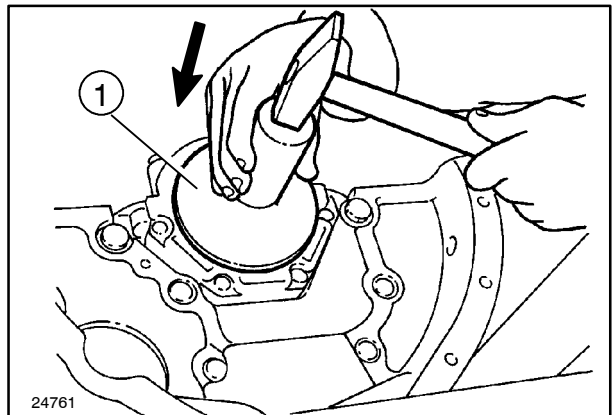

58

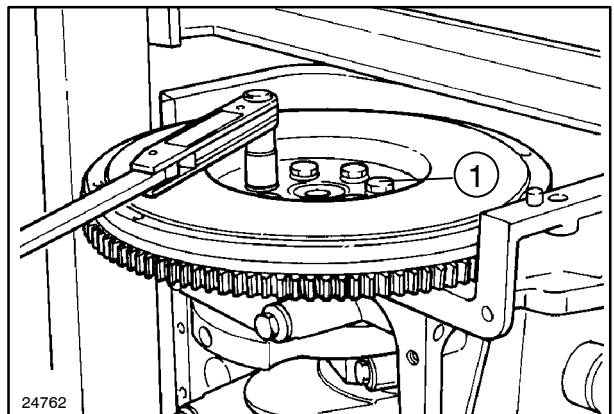

59

- Using tool **380000304** (1), tighten each flywheel bolt (2) through a further 60°.

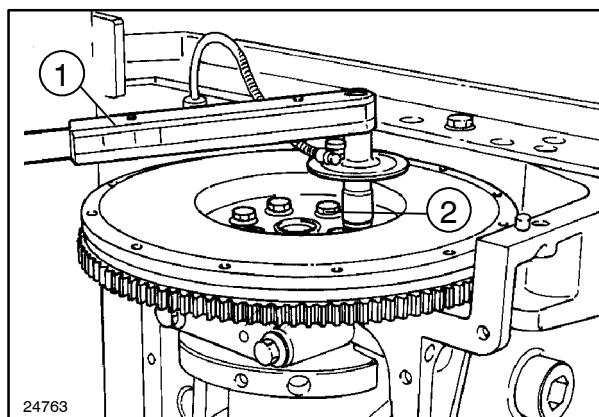

60

### MOUNTING THE PISTONS COMPLETE WITH RINGS, PINS, CONNECTING RODS, BIG END CAPS AND BEARINGS - CHECKING PROTRUSION IN RELATION TO CYLINDER BLOCK FACE

(Disassembly operations 40 and 41)

Proceed as follows:

- Lubricate pistons, rings and cylinder liners with engine oil prior to fitting.
- Using piston ring pliers **380000221** fit the piston rings. Make sure that the piston ring gaps are offset at 180°.
- Fit tool **380000220** (1) to insert the pistons (2) in the cylinder sleeves, taking care not to offset the gaps in the rings (described in the previous point).
- Insert the piston / connecting rod into the cylinder liner, checking that the connecting rod number corresponds with the cylinder number and that the number stamped on the connecting rod is facing away from the camshaft.
- Fit the big-end caps (1), complete with shells, to the crankpins and tighten the cap bolts (2) to a torque of 40 Nm (4.1 kgm).
- Using tool **380000304** (1), tighten each big-end cap bolt (2) through a further 60°.

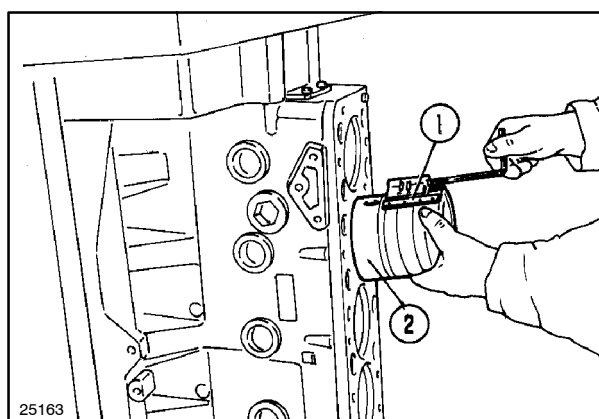

61

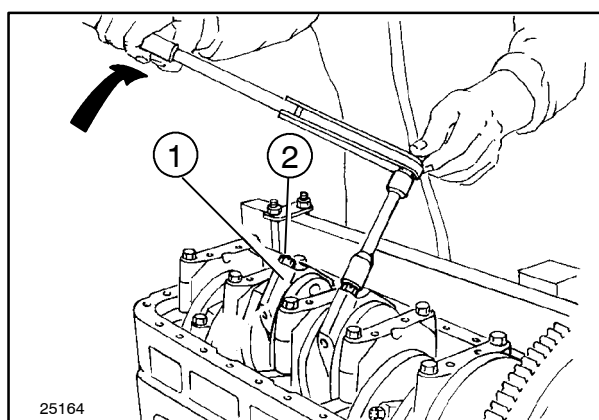

62

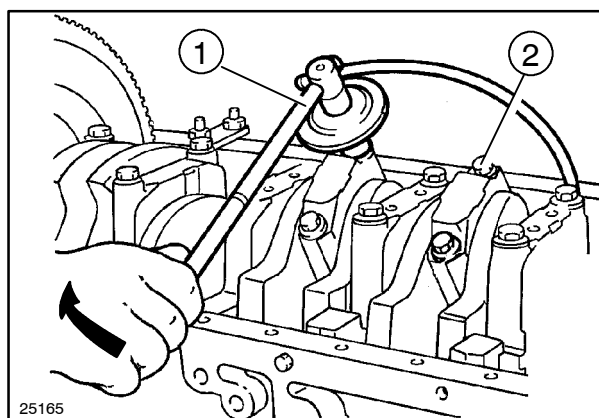

63

- Rotate the engine on the stand through 180° and clean the upper face of the cylinder block. Bring the pistons (2), up to TDC and, using a dial gauge with a magnetic base (1), check that the piston (2) protrusion from the cylinder block face is within the tolerance limits specified on page 13.

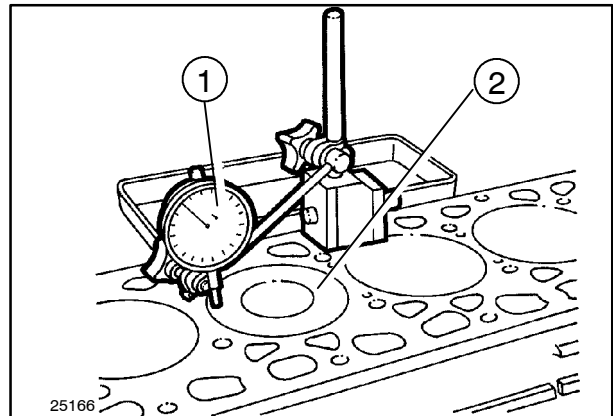

64

## SYNCHRONISING THE TIMING GEARS

### (Disassembly operations 32 to 36)

Proceed as follows:

- Remove the cover of the flywheel housing inspection window and its gasket.

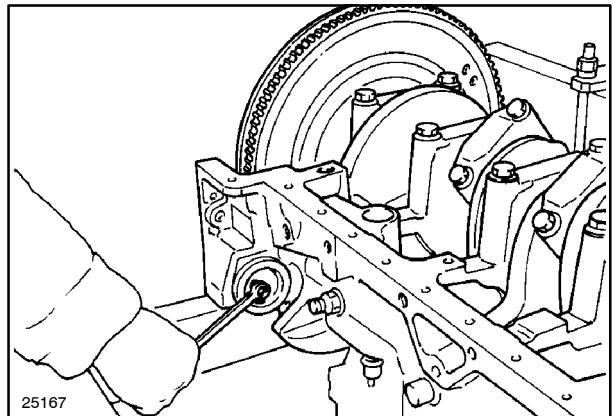

65

- Rotate the crankshaft to bring cylinder no. 1 to TDC (compression stroke). Look through the inspection window to check that the notch in degrees aligns with the index mark, according to the type of BOSCH pump installed on the tractor (see pages 6-8-10) with the indicator.

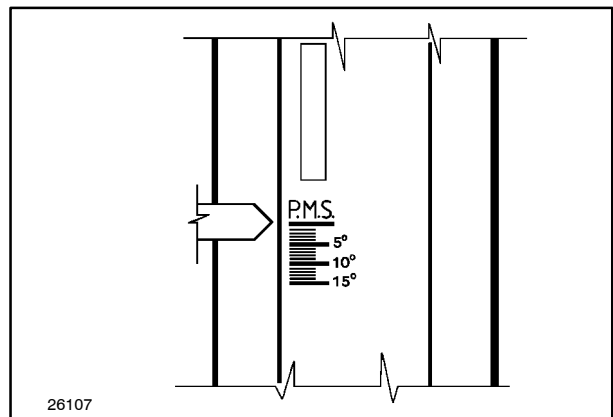

66

- Fit the timing gears, making sure that the various reference marks on the gears are aligned.

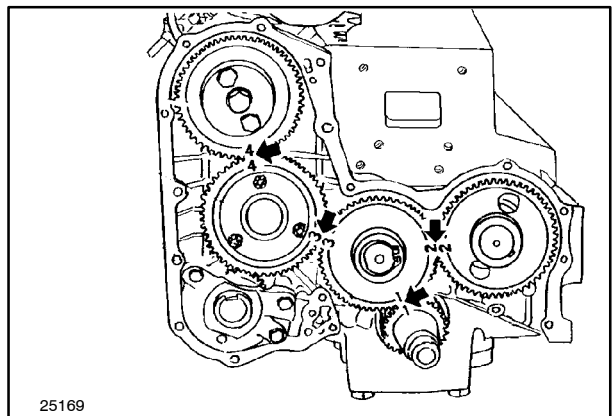

67

## REFITTING THE BOSCH INJECTION PUMP

### (Disassembly operation 6)

- Fit the BOSCH injection pump and proceed with the injection pump timing, as described on page 80.

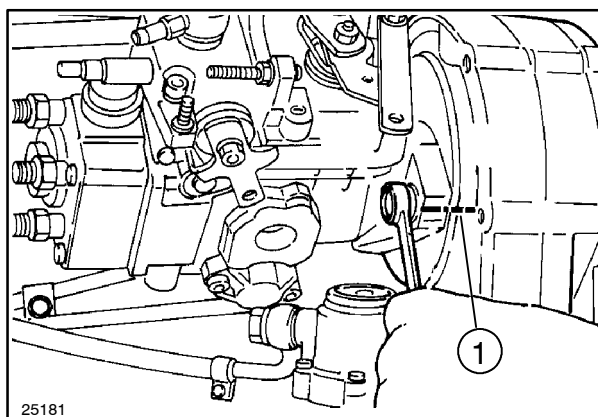

68

## FITTING THE CYLINDER HEAD GASKET

### (Disassembly operation 22)

Proceed as follows:

- Before fitting the cylinder head, carefully clean and degrease the mating surface of the cylinder block. Locate the cylinder head gasket (1) with the word **UP** uppermost.

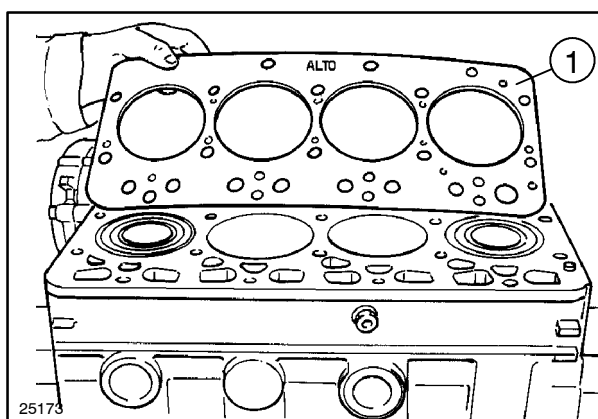

69

## FITTING AND TIGHTENING THE CYLINDER HEAD

### (Disassembly operation 21)

Proceed as follows:

- Lower the cylinder head onto the block and screw in the cylinder head bolts (1, fig. 71) so that the heads are brought into contact with the cylinder head.
- Tightening sequence for cylinder head bolts (1, fig. 71) on 4-cylinder engines to be followed for tightening stages (A = fan end).
- Tighten the bolts (1) to a torque of 70 Nm (7.1 kgm) in the sequence indicated above (1<sup>st</sup> stage).
- Check the torque of all the bolts in the sequence indicated above (2<sup>nd</sup> stage).

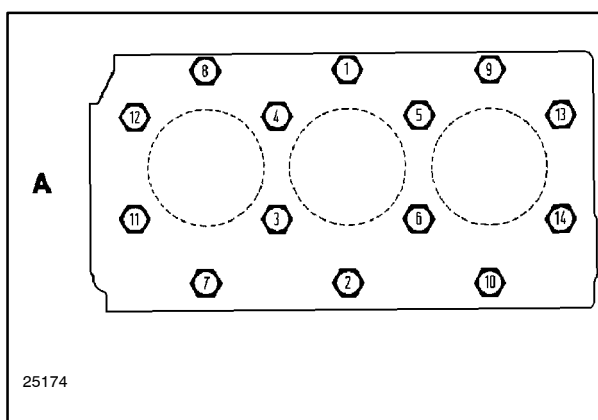

70

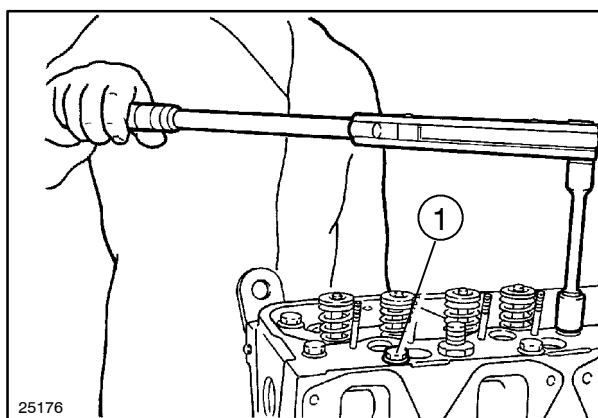

71



**Suggest:**

**If the above button click is invalid.**

**Please download this document**

**first, and then click the above link**

**to download the complete manual.**

**Thank you so much for reading**

- Using tool **380000304** (1) tighten each bolt (2) in sequence through 90° (3<sup>rd</sup> phase) and then through a further 90° (4<sup>th</sup> phase) in the sequence indicated above.

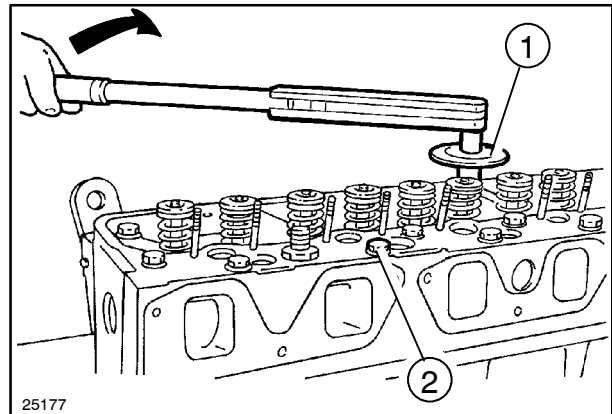

72

## ADJUSTING VALVE / ROCKER ARM CLEARANCE

### (Disassembly operation 18)

- Before refitting the rocker cover, adjust the valve clearances as described on pages 76 and 77.
- Tighten the rocker arm adjuster screw locknuts (1) to the torque specified on page 20.

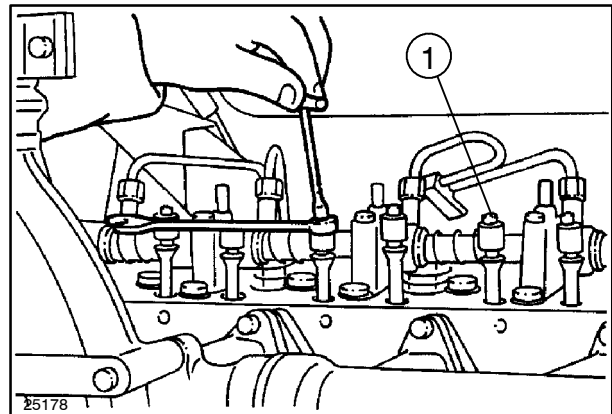

73

## FITTING THE INJECTORS

### (Disassembly operation 17)

Proceed as follows:

- Insert the injectors (2) in their respective bores.
- Position the injector support brackets and fit the spherical washers.
- Screw the bracket retaining nuts (1) up to the spherical washers then, using a torque wrench, tighten to the torque specified on page 20 in two stages :  
1<sup>st</sup> stage, tighten nuts to 10 Nm (1 kgm),  
2<sup>nd</sup> stage, tighten nuts to 25 Nm (2.6 kgm).
- Tighten the injector leak-off pipe union.
- Tighten the high-pressure fuel line union.

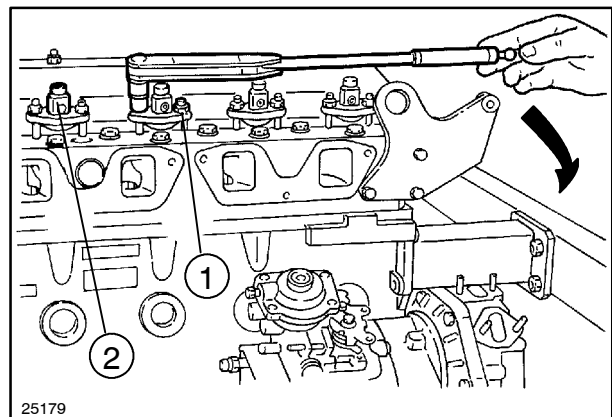

74

## ADJUSTING BELT TENSION ON THE COOLING SYSTEM

### (Disassembly operations 9)

**NOTE:** Tension the belt correctly, as shown on page 68.

**<https://www.ebooklibonline.com>**

Hello dear friend!

Thank you very much for reading.

Enter the link into your browser.

The full manual is available for immediate download.

**<https://www.ebooklibonline.com>**