

JOHN DEERE
WORLDWIDE COMMERCIAL & CONSUMER
EQUIPMENT DIVISION

Spin-Steer Lawn Tractor
SST15, SST16 and SST18

TM1908 JULY 2004

TECHNICAL MANUAL



JOHN DEERE

North American Version
Litho in U.S.A.

INTRODUCTION

Manual Description

This technical manual is written for an experienced technician and contains sections that are specifically for this product. It is a part of a total product support program.

The manual is organized so that all the information on a particular system is kept together. The order of grouping is as follows:

- Table of Contents
- Specifications and Information
- Identification Numbers
- Tools and Materials
- Component Location
- Schematics and Harnesses
- Theory of Operation
- Operation and Diagnostics
- Diagnostics
- Tests and Adjustments
- Repair
- Other

NOTE: Depending on the particular section or system being covered, not all of the above groups may be used.

The bleed tabs for the pages of each section will align with the sections listed on this page. Page numbering is consecutive from the beginning of the Safety section through the last section.

We appreciate your input on this manual. If you find any errors or want to comment on the layout of the manual please contact us.

Safety

Specifications and Information

Engine (Briggs & Stratton)

Engine (Kohler)

Electrical

Power Train

Steering

Brakes

Attachments

Miscellaneous

All information, illustrations and specifications in this manual are based on the latest information at the time of publication. The right is reserved to make changes at any time without notice.

COPYRIGHT© 2004
Deere & Co.
John Deere Worldwide Commercial and
Consumer Equipment Division
All rights reserved
Previous Editions
COPYRIGHT© 2002

SAFETY

Recognize Safety Information

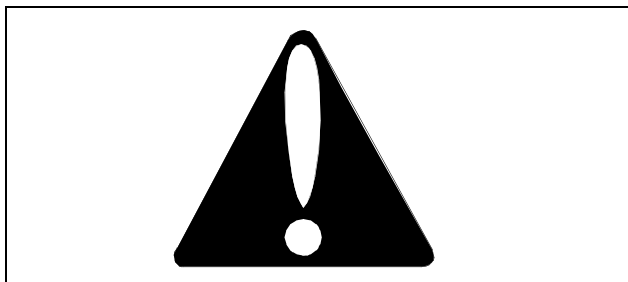

This is the safety-alert symbol. When you see this symbol on your machine or in this manual, be alert to the potential for personal injury.

Follow recommended precautions and safe servicing practices.

Understand Signal Words

A signal word - DANGER, WARNING, or CAUTION - is used with the safety-alert symbol. DANGER identifies the most serious hazards.

DANGER or WARNING safety signs are located near specific hazards. General precautions are listed on CAUTION safety signs. CAUTION also calls attention to safety messages in this manual.

Replace Safety Signs

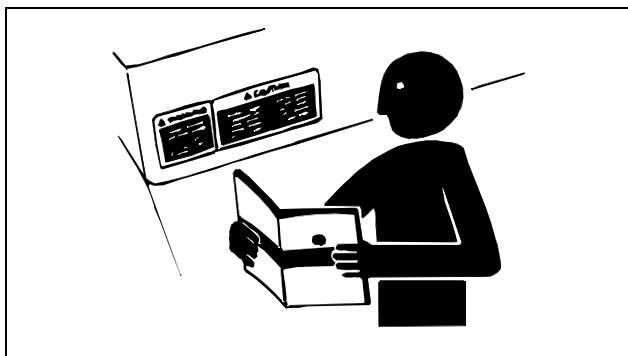

Replace missing or damaged safety signs. See the machine operator's manual for correct safety sign placement.

Be Prepared For Emergencies

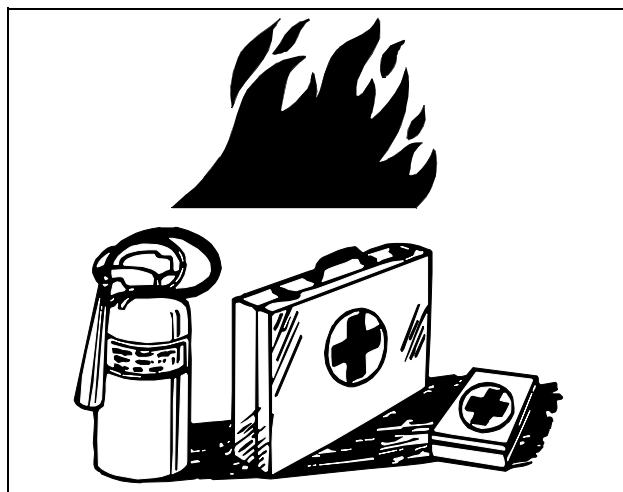

- When you work around fuel, do not smoke or work near heaters or other fire hazards.
- Store flammable fluids away from fire hazards. Do not incinerate or puncture pressurized containers.
- Make sure machine is clean of trash, grease, and debris.
- Do not store oily rags; they can ignite and burn spontaneously.
- Be prepared if a fire starts.
- Keep a first aid kit and fire extinguisher handy.
- Keep emergency numbers for doctors, ambulance service, hospital, and fire department near your telephone.

Use Care In Handling and Servicing Batteries

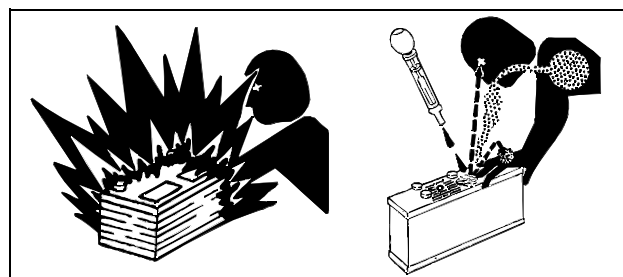

Prevent Battery Explosions

- Keep sparks, lighted matches, and open flame away from the top of battery. Battery gas can explode.
- Never check battery charge by placing a metal object across the posts. Use a volt-meter or hydrometer.
- Do not charge a frozen battery; it may explode. Warm battery to 16°C (60°F).

<https://www.ebooklibonline.com>

Hello dear friend!

Thank you very much for reading.

Enter the link into your browser.

The full manual is available for immediate download.

<https://www.ebooklibonline.com>

SAFETY

Prevent Acid Burns

- Sulfuric acid in battery electrolyte is poisonous. It is strong enough to burn skin, eat holes in clothing, and cause blindness if splashed into eyes.

Avoid acid burns by:

1. Filling batteries in a well-ventilated area.
2. Wearing eye protection and rubber gloves.
3. Avoiding breathing fumes when electrolyte is added.
4. Avoiding spilling or dripping electrolyte.
5. Use proper jump start procedure.

If you spill acid on yourself:

1. Flush your skin with water.
2. Apply baking soda or lime to help neutralize the acid.
3. Flush your eyes with water for 10 - 15 minutes.
4. Get medical attention immediately.

If acid is swallowed:

1. Drink large amounts of water or milk.
2. Then drink milk of magnesia, beaten eggs, or vegetable oil.
3. Get medical attention immediately.

Wear Protective Clothing

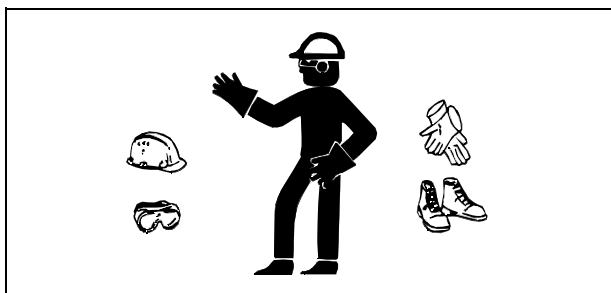

Wear close fitting clothing and safety equipment appropriate to the job.

Prolonged exposure to loud noise can cause impairment or loss of hearing. Wear a suitable hearing protective device such as earmuffs or earplugs to protect against objectionable or uncomfortable loud noises.

Operating equipment safely requires the full attention of the operator. Do not wear radio or music headphones while operating machine.

Service Machines Safely

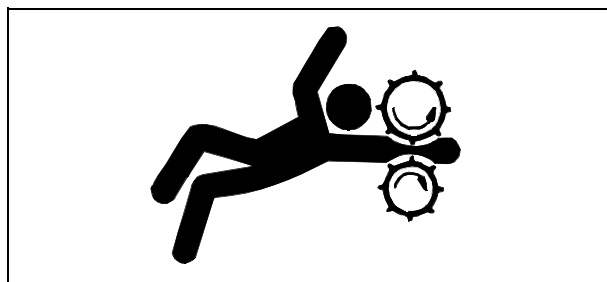

Tie long hair behind your head. Do not wear a necktie, scarf, loose clothing, or necklace when you work near machine tools or moving parts. If these items were to get caught, severe injury could result.

Remove rings and other jewelry to prevent electrical shorts and entanglement in moving parts.

Avoid Injury From Rotating Blades, Augers and PTO Shafts

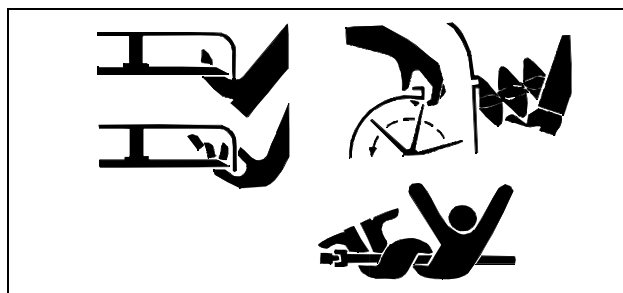

Keep hands and feet away while machine is running. Shut off power to service, lubricate or remove mower blades, augers or PTO shafts.

Use Proper Tools

Use tools appropriate to the work. Makeshift tools and procedures can create safety hazards. Use power tools only to loosen threaded parts and fasteners. For loosening and tightening hardware, use the correct size tools. **DO NOT** use U.S. measurement tools on metric fasteners. Avoid bodily injury caused by slipping wrenches. Use only service parts meeting John Deere specifications.

Illuminate Work Area Safely

Illuminate your work area adequately but safely. Use a portable safety light for working inside or under the machine. Make sure the bulb is enclosed by a wire cage. The hot filament of an accidentally broken bulb can ignite spilled fuel or oil.

SAFETY

Work In Clean Area

Before starting a job:

1. Clean work area and machine.
2. Make sure you have all necessary tools to do your job.
3. Have the right parts on hand.
4. Read all instructions thoroughly; do not attempt shortcuts.

Park Machine Safely

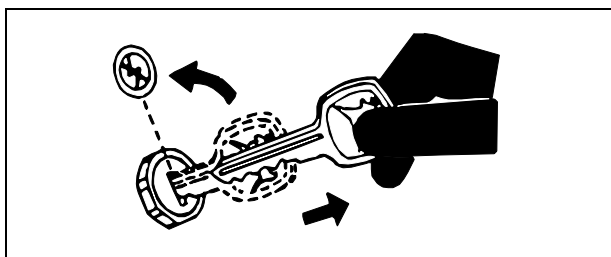

Before working on the machine:

1. Lower all equipment to the ground.
2. Stop the engine and remove the key.
3. Disconnect the battery ground strap.
4. Hang a "DO NOT OPERATE" tag in operator station.

Support Machine Properly and Use Proper Lifting Equipment

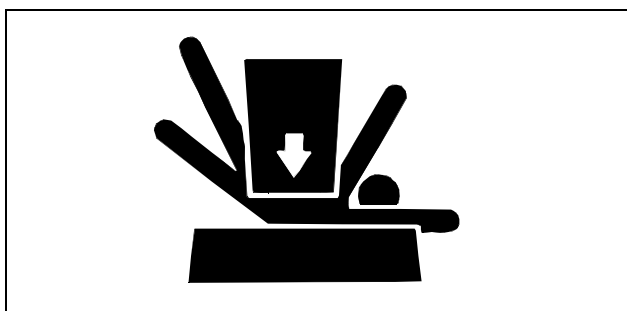

If you must work on a lifted machine or attachment, securely support the machine or attachment.

Do not support the machine on cinder blocks, hollow tiles, or props that may crumble under continuous load. Do not work under a machine that is supported solely by a jack. Follow recommended procedures in this manual.

Lifting heavy components incorrectly can cause severe injury or machine damage. Follow recommended procedure for removal and installation of components in the manual.

Using High Pressure Washers

Directing pressurized water at electronic/electrical components or connectors, bearings, hydraulic seals, fuel injection pumps or other sensitive parts and components may cause product malfunctions. Reduce pressure and spray at a 45 to 90 degree angle.

Work In Ventilated Area

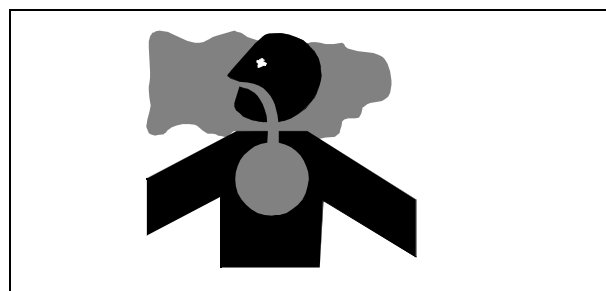

Engine exhaust fumes can cause sickness or death. If it is necessary to run an engine in an enclosed area, remove the exhaust fumes from the area with an exhaust pipe extension.

If you do not have an exhaust pipe extension, open the doors and get outside air into the area.

Warning: California Proposition 65 Warning

Gasoline engine exhaust from this product contains chemicals known to the State of California to cause cancer, birth defects, or other reproductive harm.

Remove Paint Before Welding Or Heating

Avoid potentially toxic fumes and dust. Hazardous fumes can be generated when paint is heated by welding, soldering, or using a torch. Do all work outside or in a well ventilated area. Dispose of paint and solvent properly. Remove paint before welding or heating: If you sand or grind paint, avoid breathing the dust. Wear an approved respirator. If you use solvent or paint stripper, remove stripper with soap and water before welding. Remove solvent or paint stripper containers and other flammable material from area. Allow fumes to disperse at least 15 minutes before welding or heating.

Avoid Harmful Asbestos Dust

Avoid breathing dust that may be generated when handling components containing asbestos fibers. Inhaled asbestos fibers may cause lung cancer.

Components in products that may contain asbestos fibers are brake pads, brake band and lining assemblies, clutch

SAFETY

plates, and some gaskets. The asbestos used in these components is usually found in a resin or sealed in some way. Normal handling is not hazardous as long as airborne dust containing asbestos is not generated.

Avoid creating dust. Never use compressed air for cleaning. Avoid brushing or grinding material containing asbestos. When servicing, wear an approved respirator. A special vacuum cleaner is recommended to clean asbestos. If not available, apply a mist of oil or water on the material containing asbestos. Keep bystanders away from the area.

Service Tires Safely



Explosive separation of a tire and rim parts can cause serious injury or death.

Do not attempt to mount a tire unless you have the proper equipment and experience to perform the job.

Always maintain the correct tire pressure. Do not inflate the tires above the recommended pressure. Never weld or heat a wheel and tire assembly. The heat can cause an increase in air pressure resulting in a tire explosion. Welding can structurally weaken or deform the wheel.

When inflating tires, use a clip-on chuck and extension hose long enough to allow you to stand to one side and NOT in front of or over the tire assembly. Use a safety cage if available.

Check wheels for low pressure, cuts, bubbles, damaged rims or missing lug bolts and nuts.

Handle Chemical Products Safely

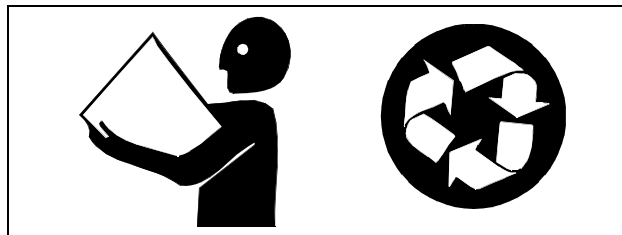

Direct exposure to hazardous chemicals can cause serious injury. Potentially hazardous chemicals used with John Deere equipment include such items as lubricants, coolants, paints, and adhesives.

A Material Safety Data Sheet (MSDS) provides specific details on chemical products: physical and health hazards, safety procedures, and emergency response techniques. Check the MSDS before you start any job using a hazardous chemical. That way you will know exactly what the risks are and how to do the job safely. Then follow procedures and recommended equipment.

Dispose Of Waste Properly

Improperly disposing of waste can threaten the environment and ecology. Potentially harmful waste used with John Deere equipment include such items as oil, fuel, coolant, brake fluid, filters, and batteries. Use leakproof containers when draining fluids. Do not use food or beverage containers that may mislead someone into drinking from them. Do not pour waste onto the ground, down a drain, or into any water source. Inquire on the proper way to recycle or dispose of waste from your local environmental or recycling center, or from your John Deere dealer.

Live With Safety



Before returning machine to customer, make sure machine is functioning properly, especially the safety systems. Install all guards and shields.

GENERAL VEHICLE SPECIFICATIONS TABLE OF CONTENTS













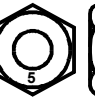









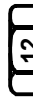

Table of Contents

Fastener Torques	7
Metric Fastener Torque Values	7
Inch Fastener Torque Values	8
General Information	9
Gasoline	9
Gasoline Storage.....	9
Engine Oil.....	9
Engine Break-In Oil	10
Chassis Grease.....	11
Hydrostatic Transmission Oil.....	11
Synthetic Lubricants	11
Alternative Lubricants.....	11
Lubricant Storage	12
Mixing of Lubricants	12
Serial Number Locations	12
Machine Product Identification Number	12
Engine Serial Number	12
Transaxle Serial Number.....	12

GENERAL VEHICLE SPECIFICATIONS FASTENER TORQUES

Fastener Torques

Metric Fastener Torque Values

Property Class and Head Markings	4.8   	8.8 9.8    	10.9  	12.9    
Property Class and Nut Markings	5   	10   	10   	12   

MIF

SIZE	Class 4.8		Class 8.8 or 9.8				Class 10.9				Class 12.9					
	Lubricated a		Dry a		Lubricated a		Dry a		Lubricated a		Dry a		Lubricated a		Dry a	
	N•m	lb-ft	N•m	lb-ft	N•m	lb-ft	N•m	lb-ft	N•m	lb-ft	N•m	lb-ft	N•m	lb-ft	N•m	lb-ft
M6	4.8	3.5	6	4.5	9	6.5	11	8.5	13	9.5	17	12	15	11.5	19	14.5
M8	12	8.5	15	11	22	16	28	20	32	24	40	30	37	28	47	35
M10	23	17	29	21	43	32	55	40	63	47	80	60	75	55	95	70
M12	40	29	50	37	75	55	95	70	110	80	140	105	130	95	165	120
M14	63	47	80	60	120	88	150	110	175	130	225	165	205	150	260	109
M16	100	73	125	92	190	140	240	175	275	200	350	225	320	240	400	300
M18	135	100	175	125	260	195	330	250	375	275	475	350	440	325	560	410
M20	190	140	240	180	375	275	475	350	530	400	675	500	625	460	800	580
M22	260	190	330	250	510	375	650	475	725	540	925	675	850	625	1075	800
M24	330	250	425	310	650	475	825	600	925	675	1150	850	1075	800	1350	1000
M27	490	360	625	450	950	700	1200	875	1350	1000	1700	1250	1600	1150	2000	1500
M30	675	490	850	625	1300	950	1650	1200	1850	1350	2300	1700	2150	1600	2700	2000
M33	900	675	1150	850	1750	1300	2200	1650	2500	1850	3150	2350	2900	2150	3700	2750
M36	1150	850	1450	1075	2250	1650	2850	2100	3200	2350	4050	3000	3750	2750	4750	3500

DO NOT use these hand torque values if a different torque value or tightening procedure is given for a specific application. Torque values listed are for general use only and include a ±10% variance factor. Check tightness of fasteners periodically. DO NOT use air powered wrenches.

Shear bolts are designed to fail under predetermined loads. Always replace shear bolts with identical grade.

Fasteners should be replaced with the same grade. Make sure fastener threads are clean and that you properly start thread engagement. This will prevent them from failing when tightening.

When bolt and nut combination fasteners are used, torque values should be applied to the NUT instead of the bolt head.











Tighten toothed or serrated-type lock nuts to the full torque value.

a "Lubricated" means coated with a lubricant such as engine oil, or fasteners with phosphate and oil coatings. "Dry" means plain or zinc plated (yellow dichromate - Specification JDS117) without any lubrication.

Reference: JDS - G200.

GENERAL VEHICLE SPECIFICATIONS FASTENER TORQUES

Inch Fastener Torque Values

SAE Grade and Head Markings	1 or 2 ^b No Marks 	5  5.1  5.2 	8  8.2 
SAE Grade and Nut Markings	2 No Marks 	5  	8  

MIF

SIZE	Grade 1		Grade 2b				Grade 5, 5.1 or 5.2				Grade 8 or 8.2					
	Lubricated a	Dry a	Lubricated a	Dry a	Lubricated a	Dry a	Lubricated a	Dry a	Lubricated a	Dry a	Lubricated a	Dry a				
	N•m	lb-ft	N•m	lb-ft	N•m	lb-ft	N•m	lb-ft	N•m	lb-ft	N•m	lb-ft	N•m	lb-ft	N•m	lb-ft
1/4	3.7	2.8	4.7	3.5	6	4.5	7.5	5.5	9.5	7	12	9	13.5	10	17	12.5
5/16	7.7	5.5	10	7	12	9	15	11	20	15	25	18	28	21	35	26
3/8	14	10	17	13	22	16	27	20	35	26	44	33	50	36	63	46
7/16	22	16	28	20	35	26	44	32	55	41	70	52	80	58	100	75
1/2	33	25	42	31	53	39	67	50	85	63	110	80	120	90	150	115
9/16	48	36	60	45	75	56	95	70	125	90	155	115	175	130	225	160
5/8	67	50	85	62	105	78	135	100	170	125	215	160	215	160	300	225
3/4	120	87	150	110	190	140	240	175	300	225	375	280	425	310	550	400
7/8	190	140	240	175	190	140	240	175	490	360	625	450	700	500	875	650
1	290	210	360	270	290	210	360	270	725	540	925	675	1050	750	1300	975
1-1/8	470	300	510	375	470	300	510	375	900	675	1150	850	1450	1075	1850	1350
1-1/4	570	425	725	530	570	425	725	530	1300	950	1650	1200	2050	1500	2600	1950
1-3/8	750	550	950	700	750	550	950	700	1700	1250	2150	1550	2700	2000	3400	2550
1-1/2	1000	725	1250	925	990	725	1250	930	2250	1650	2850	2100	3600	2650	4550	3350

DO NOT use these hand torque values if a different torque value or tightening procedure is given for a specific application. Torque values listed are for general use only and include a $\pm 10\%$ variance factor. Check tightness of fasteners periodically. DO NOT use air powered wrenches.

Shear bolts are designed to fail under predetermined loads. Always replace shear bolts with identical grade.

Fasteners should be replaced with the same grade. Make sure fastener threads are clean and that you properly start thread engagement. This will prevent them from failing when tightening.

When bolt and nut combination fasteners are used, torque values should be applied to the NUT instead of the bolt head.

Tighten toothed or serrated-type lock nuts to the full torque value.

a "Lubricated" means coated with a lubricant such as engine oil, or fasteners with phosphate and oil coatings. "Dry" means plain or zinc plated (yellow dichromate - Specification JDS117) without any lubrication.

b "Grade 2" applies for hex cap screws (Not Hex Bolts) up to 152 mm (6 in.) long. "Grade 1" applies for hex cap screws over 152 mm (6 in.) long, and for all other types of bolts and screws of any length.

Reference: JDS - G200

GENERAL VEHICLE SPECIFICATIONS GENERAL INFORMATION

General Information

Gasoline



CAUTION: Avoid Injury! Gasoline is HIGHLY FLAMMABLE, handle it with care.

DO NOT refuel machine while:

- Indoors, always fill gas tank outdoors;
- Machine is near an open flame or sparks;
- Engine is running, STOP engine;
- Engine is hot, allow it to cool sufficiently first;
- smoking.

Help prevent fires:

- Fill gas tank to bottom of filler neck only;
- Be sure fill cap is tight after fueling;
- Clean up any gas spills IMMEDIATELY;
- Keep machine clean and in good repair - free of excess grease, oil, debris, and faulty or damaged parts.

Any storage of machines with gas left in tank should be in an area that is well ventilated to prevent possible igniting of fumes by an open flame or spark, this includes any appliance with a pilot light.

To prevent fire or explosion caused by STATIC ELECTRIC DISCHARGE during fueling:

- **ONLY use a clean, approved POLYETHYLENE PLASTIC fuel container and funnel WITHOUT any metal screen or filter.**

To avoid engine damage:

- DO NOT mix oil with gasoline;
- **ONLY use clean, fresh unleaded gasoline with an octane rating (anti-knock index) of 87 or higher;**
- fill gas tank at the end of each day's operation to help prevent condensation from forming inside a partially filled tank;
- keep up with specified service intervals.

Use of alternative oxygenated, gasohol blended, unleaded gasoline is acceptable as long as:

- the ethyl or grain alcohol blends DO NOT exceed 10% by volume or,
- methyl tertiary butyl ether (MTBE) blends DO NOT exceed 15% by volume.

RFG (reformulated) gasoline is acceptable for all machines designed for use of regular unleaded fuel. Older machines (that were designed for leaded fuel) may see some accelerated valve and seat wear.

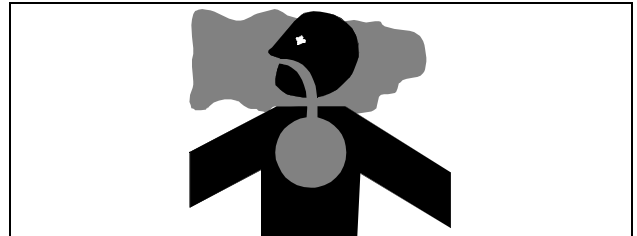

MIF

IMPORTANT: Avoid damage! California Proposition 65 Warning: Gasoline engine exhaust from this product contains chemicals known to the State of California to cause cancer, birth defects, or other reproductive harm.

Gasoline Storage

IMPORTANT: Avoid damage! Keep all dirt, scale, water or other foreign material out of gasoline.

Keep gasoline stored in a safe, protected area. Storage of gasoline in a clean, properly marked ("UNLEADED GASOLINE") POLYETHYLENE PLASTIC container WITHOUT any metal screen or filter is recommended. DO NOT use de-icers to attempt to remove water from gasoline or depend on fuel filters to remove water from gasoline. Use a water separator installed in the storage tank outlet. BE SURE to properly discard unstable or contaminated gasoline. When storing the machine or gasoline, it is recommended that you add **John Deere Gasoline Conditioner and Stabilizer (TY15977)** or an equivalent to the gasoline. BE SURE to follow directions on container and to properly discard empty container.

Engine Oil

Use the appropriate oil viscosity based on the expected air temperature range during the period between recommended oil changes. Operating outside of these recommended oil air temperature ranges may cause premature engine failure.

The following John Deere oils are **PREFERRED**:

- **TURF - GARD® - SAE 10W-30;**
- **PLUS - 4® - SAE 10W-30;**

The following John Deere oils are **also recommended**, based on their specified temperature range:

- **TORQ - GARD SUPREME® - SAE 5W-30.**
- **PLUS - 4® - SAE 10W-40;**

GENERAL VEHICLE SPECIFICATIONS GENERAL INFORMATION

- **TORQ - GARD SUPREME® - SAE 30.**

Other oils may be used if above John Deere oils are not available, provided they meet one of the following specifications:

- SAE 10W-40 - API Service Classifications SG or higher;
- SAE 5W-30 - API Service Classification SG or higher;
- SAE 10W-30 - API Service Classifications SG or higher;
- SAE 30 - API Service Classification SC or higher.

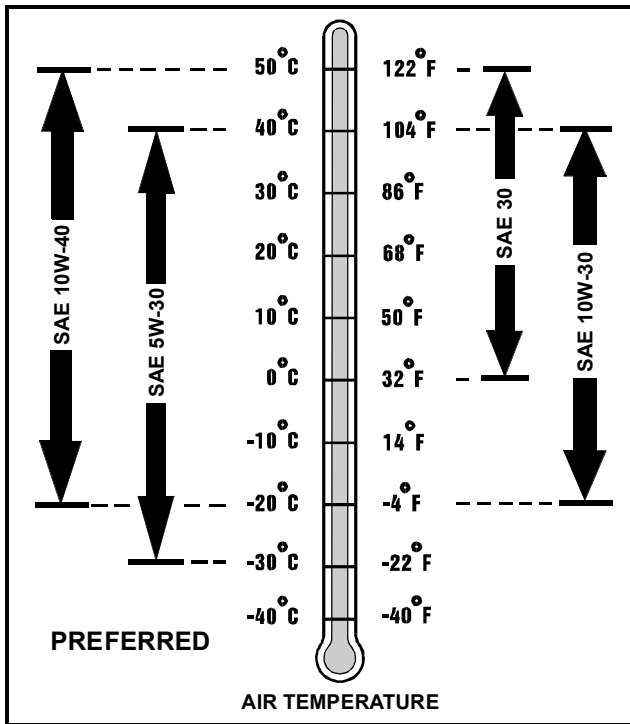

Engine Break-In Oil

IMPORTANT: Avoid damage! ONLY use a quality break-in oil in rebuilt or remanufactured engines for the first 5 hours (maximum) of operation. DO NOT use oils with heavier viscosity weights than SAE 5W-30 or oils meeting specifications API SG or SH, these oils will not allow rebuilt or remanufactured engines to break-in properly.

The following John Deere oil is **PREFERRED**:

- John Deere **BREAK-IN ENGINE OIL.**

John Deere BREAK-IN ENGINE OIL is formulated with special additives for aluminum and cast iron type engines to allow the power cylinder components (pistons, rings, and liners as well) to “wear-in” while protecting other engine components, valve train and gears, from abnormal wear. Engine rebuild instructions should be followed closely to determine if special requirements are necessary.

John Deere BREAK-IN ENGINE OIL is also recommended for non-John Deere engines, both aluminum and cast iron types.

The following John Deere oil is **also recommended as a break-in engine oil**:

- **TORQ - GARD SUPREME® - SAE 5W-30.**

If the above recommended John Deere oils are not available, use a break-in engine oil meeting the following specification during the first 5 hours (maximum) of operation:

- SAE 5W-30 - API Service Classification SE or higher.
- SAE 5W-30 - CCMC Specification G4 or higher.

IMPORTANT: Avoid damage! After the break-in period, use the John Deere oil that is recommended for this engine.

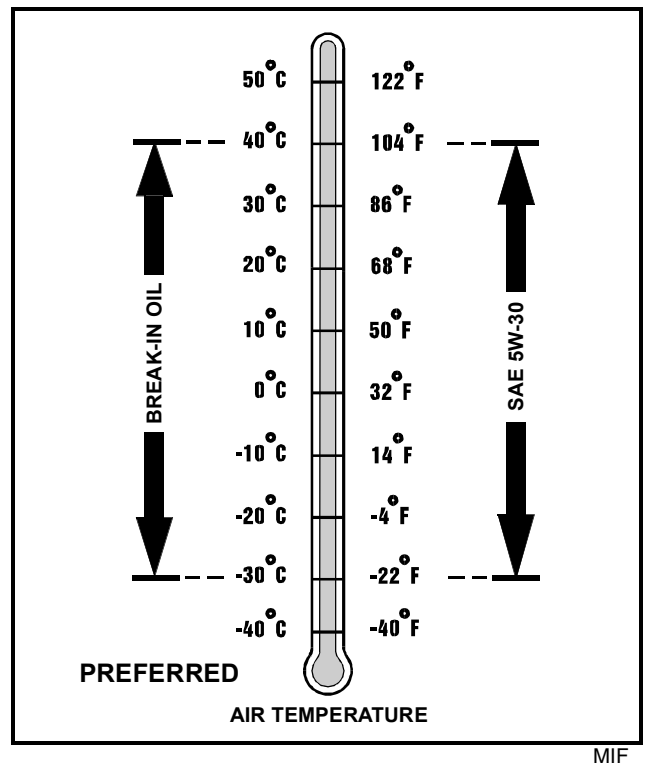

John Deere Dealers: You may want to cross-reference the following publications to recommend the proper oil for your customers:

- Module DX, ENOIL4 in JDS-G135;
- Section 530, Lubricants & Hydraulics, of the John Deere Merchandise Sales Guide;
- Lubrication Sales Manual PI7032.

GENERAL VEHICLE SPECIFICATIONS GENERAL INFORMATION

Chassis Grease

Use the following grease based on the air temperature range. Operating outside of the recommended grease air temperature range may cause premature failures.

IMPORTANT: Avoid damage! ONLY use a quality grease in this application. DO NOT mix any other greases in this application. DO NOT use any BIO-GREASE in this application.

The following John Deere grease is PREFERRED:

- **HIGH-TEMPERATURE EP GREASE® - JDM J13E4, NLGI Grade 2.**
- **GREASE-GARD™ - JDM J13E4, NLGI Grade 2.**

Other greases may be used if above preferred John Deere grease is not available, provided they meet the following specification:

- John Deere Standard JDM J13E4, NLGI Grade 2.

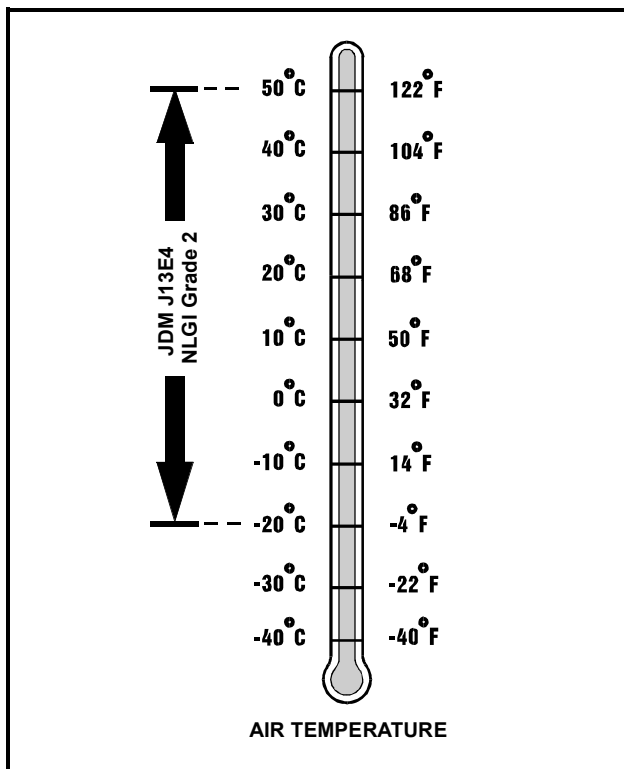

John Deere Dealers: You may want to cross-reference the following publications to recommend the proper grease for your customers:

- Module DX, GRE A1 in JDS-G135;
- Section 530, Lubricants & Hydraulics, of the John Deere Merchandise Sales Guide;
- Lubrication Sales Manual P17032.

Hydrostatic Transmission Oil

These machines are equipped with a internal wet disc brake transmission.

IMPORTANT: Avoid damage! ONLY use HY-GARD® J20D oil in this transmission. Mixing of two viscosity grade oils is NOT RECOMMENDED. DO NOT use type "F" automatic transmission fluid.

The following oil is RECOMMENDED:

- **HY-GARD J20D OIL**

John Deere Dealers: You may want to cross-reference the following publications to recommend the proper oil for your customers:

- Module DX, ENOIL2 in JDS - G135;
- Section 530, Lubricants & Hydraulics, of the John Deere Merchandise Sales Guide;
- Lubrication Sales Manual P17032.

Synthetic Lubricants

Synthetic lubricants may be used in John Deere equipment if they meet the applicable performance requirements (industry classification and/or military specification) as shown in this manual.

The recommended air temperature limits and service or lubricant change intervals should be maintained as shown in the operator's manual.

Avoid mixing different brands, grades, or types of oil. Oil manufacturers blend additives in their oils to meet certain specifications and performance requirements. Mixing different oils can interfere with the proper functioning of these additives and degrade lubricant performance.

Alternative Lubricants

Conditions in certain geographical areas outside the United States and Canada may require different lubricant recommendations than the ones printed in this technical manual or the operator's manual. Consult with your John Deere Dealer, or Sales Branch, to obtain the alternative lubricant recommendations.

IMPORTANT: Avoid damage! Use of alternative lubricants could cause reduced life of the component.

If alternative lubricants are to be used, it is recommended that the factory fill be thoroughly removed before switching to any alternative lubricant.

GENERAL VEHICLE SPECIFICATIONS SERIAL NUMBER LOCATIONS

Lubricant Storage

All machines operate at top efficiency only when clean lubricants are used. Use clean storage containers to handle all lubricants. Store them in an area protected from dust, moisture, and other contamination. Store drums on their sides. Make sure all containers are properly marked as to their contents. Dispose of all old, used containers and their contents properly.

Mixing of Lubricants

In general, avoid mixing different brands or types of lubricants. Manufacturers blend additives in their lubricants to meet certain specifications and performance requirements. Mixing different lubricants can interfere with the proper functioning of these additives and lubricant properties which will downgrade their intended specified performance.

Serial Number Locations

Machine Product Identification Number

When ordering parts or submitting a warranty claim, it is **IMPORTANT** that the machine product identification number (PIN) and component serial numbers are included. The location of the PIN and component serial numbers are shown.



MX1475

Located on right side of frame.

Engine Serial Number



MX1474

Picture Note: Briggs and Stratton Engines

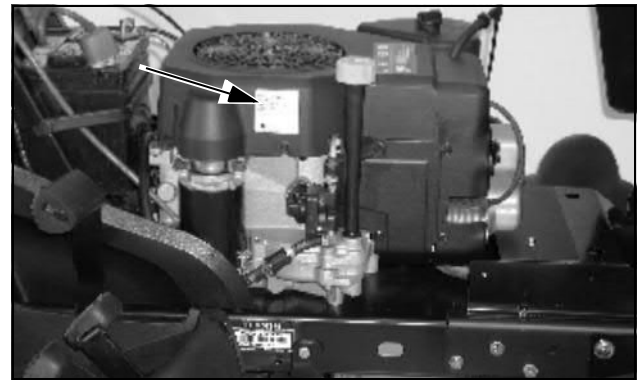

MX10553

Picture Note: Kohler Engine

Located on right side of engine.

Transaxle Serial Number

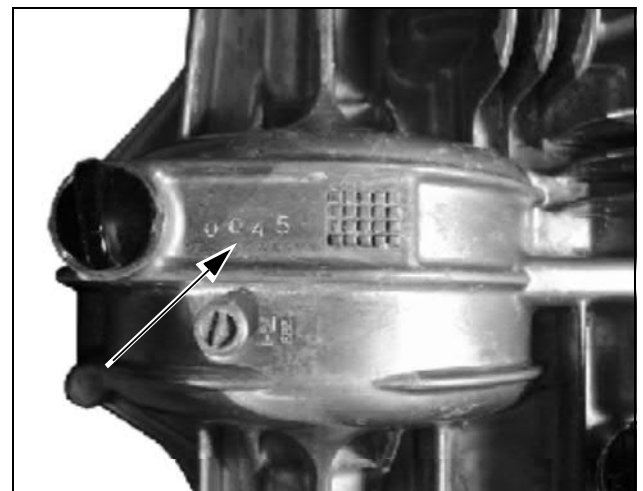

MX8551

Located (stamped) on top-front-center of transaxle.

ENGINE - BRIGGS AND STRATTON TABLE OF CONTENTS

Table of Contents	
Specifications15	Assemble Piston Rod etc..... 50
Engine Specifications15	Cylinder Bore Inspection..... 52
Tests and Adjustments Specifications.....15	Cylinder Bore Honing..... 52
Repair Specifications.....16	Cylinder Bore Cleaning..... 53
Torque Specifications.....18	Resizing Cylinder Bore 53
Diagnostics19	Flywheel Removal and Installation 54
Engine Diagnostics.....19	Crankshaft Removal and Installation 55
Tests and Adjustments26	Magneto Bearing Inspection..... 57
Throttle Cable Adjustment.....26	PTO and Cam Bearing Inspection 58
Choke Cable Adjustment.....26	Breather Valve Service 59
Governor Adjustment27	Oil Pump Removal..... 60
Carburetor Adjustment28	Starting Motor
Valve Clearance Adjustment29	Removal and Installation 61
Fuel Shutoff Solenoid Test.....29	Starting Motor Disassembly 62
Compression Test30	Starting Motor Assembly..... 64
Without Cylinder Leak Tester30	Starting Motor
With Cylinder Leak Tester.....30	Pinion Gear Replacement..... 65
Engine Oil Pressure Test31	
Ignition Armature Air Gap Adjustment.....32	
Repair.....33	
Throttle and Choke Cable	
Removal and Installation33	
Air Cleaner Removal and Installation33	
Upper Blower Housing	
Removal and Installation.....34	
Carburetor Removal and Installation.....35	
Carburetor Disassembly.....36	
Carburetor Inspection.....38	
Carburetor Assembly.....39	
Air Guides Removal and Installation41	
Engine Removal and Installation.....42	
Intake Manifold	
Removal and Installation44	
Cylinder Head	
Removal and Installation44	
Cylinder Head Inspection and Repair.....46	
Valve Removal47	
Valve Inspection and Repair47	
Valve Guide Ream48	
Valve Installation48	
Piston, Rings & Rod	
Removal and Installation48	
Piston Inspection50	
Connecting Rod Inspection50	

ENGINE - BRIGGS AND STRATTON SPECIFICATIONS

Specifications

Engine Specifications

Engine Use	SST16 and SST18
Make	Briggs and Stratton
Series	Vanguard V-Twin
Type	Gasoline
Stroke/Cycle	4

Engine Model Number:

SST16	303777
SST18	350777

Horsepower:

SST16	11.9 kW (16 hp)
SST18	13.4 kW (18 hp)

Displacement:

SST16	480 cm ³ (29.3 cu in.)
SST18	570 cm ³ (34.8 cu in.)

Bore and Stroke:

SST16	68 mm (2.68 in.)
SST18	72 mm (2.84 in.)
SST16	66 mm (2.60 in.)
SST18	70 mm (2.76 in.)

Cooling Type	Air Cooled
Lubrication	Pressurized
Oil Filter	Full Flow Filter (w/o By-Pass Valve)

Engine Oil:

With Filter	1.5 L (1.6 qt)
Without Filter	1.4 L (1.5 qt)

Air Cleaner	Paper with outer foam element
Muffler	Horizontal discharge below frame
Fuel Filter	Replaceable (In-Line Type)
Aspiration	Normal

Tests and Adjustments Specifications

Spark Plug Gap	0.76 mm (0.030 in.)
Slow Idle	1500 ± 100 rpm
Fast Idle	3350 ± 50 rpm
Crankcase Vacuum (minimum)	10.2 cm H ₂ O (4 in. H ₂ O)
Intake Vacuum (minimum)	33 cm Hg (13 in. Hg)
Valve Clearance	0.10 - 0.16 mm (0.004 - 0.006 in.)
Valve Guide Depth	0.7 mm (0.281 in.)
Oil Pump Operating Pressure	69 - 517 kPa (10 - 75 psi)

ENGINE - BRIGGS AND STRATTON SPECIFICATIONS

Repair Specifications

Valves:

Valve Guide:

Standard Dimension 6.01 - 6.02 mm (0.236 - 0.237 in.)

Wear Limit 6.05 mm (0.238 in.)

Valve Stem Standard Dimension:

Intake 5.94 - 5.96 mm (0.234 - 0.235 in.)

Exhaust 5.94 - 5.95 mm (0.234 - 0.235 in.)

Valve Stem Wear Limit:

Intake 5.92 mm (0.233 in.)

Exhaust 5.91 mm (2.328 in.)

Valve Seat Width 1.2 - 1.6 mm (0.047 - 0.062 in.)

Valve Margin 0.8 mm (0.030 in.)

Valve Face Angle 45°

Valve Seat Narrowing Angle 30°

Cylinder Bore, Pistons and Rings:

SST16 Cylinder Bore:

Standard Dimension 68.0 - 68.025 mm (2.677 - 2.678 in.)

Wear Limit 68.065 mm (2.6795 in.)

SST18 Cylinder Bore:

Standard Dimension 72.0 - 72.025 mm (2.835 - 2.836 in.)

Wear Limit 72.065 mm (2.837 in.)

Piston Pin:

Standard Dimension 17.07 - 17.08 mm (0.672 - 0.673 in.)

Wear Limit 17.06 mm (0.672 in.)

Piston Pin Bore:

Standard Dimension 17.09 - 17.10 mm (0.673 - 0.674 in.)

Wear Limit 17.12 mm (0.674 in.)

Ring End Gap:

Standard Dimension 0.20 - 0.40 mm (0.008 - 0.016 in.)

Wear Limit 0.76 mm (0.030 in.)

Compression Ring Groove Wear Limit (New Ring Installed) 0.10 mm (0.004 in.)

Oil Ring Groove Clearance Wear Limit (New Ring Installed) 0.20 mm (0.008 in.)

Connecting Rod and Crankshaft:

Connecting Rod Crankpin:

Standard Dimension 37.06 - 37.08 mm (1.459 - 1.460 in.)

Wear Limit 37.11 mm (1.461 in.)

ENGINE - BRIGGS AND STRATTON SPECIFICATIONS

Connecting Rod Piston Pin Bearing:

Standard Dimension 17.07 - 17.09 mm (0.672 - 0.673 in.)
Wear Limit 17.13 mm (0.6745 in.)

Crankshaft PTO Journal:

Standard Dimension 34.96 - 34.97 mm (1.376 - 1.377 in.)
Wear Limit 34.92 mm (1.375 in.)

Crankshaft Magneto Journal:

Standard Dimension 34.99 - 35.01 mm (1.3776 - 1.378 in.)
Wear Limit 34.95 mm (1.376 in.)

Magneto Bearing:

Standard Dimension 30.03 - 30.06 mm (1.1825 - 1.1835 in.)
Wear Limit 30.08 mm (1.184 in.)

PTO Bearing:

Standard Dimension 35.04 - 35.05 mm (1.379 - 1.380 in.)
Wear Limit 35.07 mm (1.381 in.)

Crankshaft Crankpin Journal:

Standard Dimension 37.0 - 37.02 mm (1.456 - 1.457 in.)
Wear Limit 36.95 mm (1.455 in.)

Crankshaft End Play 0.08 - 0.40 mm (0.003 - 0.015 in.)

Cam Gear PTO Journal:

Standard Dimension 19.94 - 19.96 mm (0.785 - 0.786 in.)
Wear Limit 19.92 mm (0.784 in.)

Cam Gear Magneto Journal:

Standard Dimension 15.95 - 15.97 mm (0.628 - 0.629 in.)
Wear Limit 15.93 mm (0.627 in.)

Cam Lobe:

Standard Dimension 30.33 - 30.53 mm (1.194 - 1.202 in.)
Wear Limit 30.25 mm (1.191 in.)

Cam Bearing (Magneto Side):

Standard Dimension 16.0 - 16.025 mm (0.630 - 0.631 in.)
Wear Limit 16.08 mm (0.633 in.)

Cam Bearing (PTO Side):

Standard Dimension 20.0 - 20.02 mm (0.787 - 0.788 in.)
Wear Limit 20.04 mm (0.789 in.)

ENGINE - BRIGGS AND STRATTON SPECIFICATIONS

Torque Specifications

Alternator to Cylinder Block	2.2 Nm (20 lb in.)
Air Cleaner Base to Carburetor	7 N•m (65 lb-in.)
Clutch to Crankshaft Bolt	68 N•m (50 lb-ft)
Connecting Rod Cap Screws	13 N•m (115 lb-in.)
Clutch Mounting Bolt	75 N•m (55 lb-ft)
Crankcase Cover	17 N•m (150 lb-in.)
Cylinder Head Cap Screws	19 N•m (165 lb-in.)
Cylinder Shield	7 N•m (65 lb-in.)
Engine Mounting Bolts	32 N•m (24 lb-ft)
Exhaust Manifold	17 N•m (150 lb-in.)
Flywheel Nut	175 N•m (129 lb-ft)
Fuel Shutoff Solenoid	5 N•m (45 lb-in.)
Oil Breather Mounting Bolt	3 N•m (30 lb-in.)
Oil Filter Adaptor Mounting Bolts	7 N•m (62 lb-in.)
Oil Pump Mounting Screws	7 N•m (62 lb-in.)
Rocker Arm Adjustment Lock Nut	7 N•m (62 lb-in.)
Rocker Mounting Studs	16 N•m (140 lb-in.)
Spark Plug	20 N•m (180 lb-in.)
Starting Motor Mounting Bolts	16 N•m (140 lb-in.)
Valve Cover Nuts	3 N•m (30 lb-in.)

ENGINE - BRIGGS AND STRATTON DIAGNOSTICS

Diagnostics

Engine Diagnostics



CAUTION: Avoid Injury! The engine may start to rotate at any time. Keep hands away from moving parts when testing.

Test Conditions:

- Battery fully charged.
- Operator On Seat
- PTO Switch In Off Position
- Brake On
- Key switch in run or start position as needed
- Engine running when needed

Engine Doesn't Crank

Symptom: Engine Doesn't Crank

(1) Are battery cables loose or dirty?

Yes - Tighten or clean.

No - Go to next step.

(2) Is battery fully charged? See "Battery Voltage & Specific Gravity Tests" on page 178 in the Electrical section.

No - Charge battery. See "Battery - Charge" on page 179 in the Electrical section.

Yes - Go to next step.

(3) Is key switch working correctly?

Yes - Go to next step.

No - Test switch. See "Cranking Circuit Operation" on page 138 in the Electrical section. Replace as needed.

(4) Has engine seized?

Yes - See Engine Repair Section.

No - Go to next step.

(5) Is starting motor or solenoid defective?

Yes - Repair or replace. See "Starting Solenoid Test" on page 180 or See "No-Load Starting Motor Amperage Draw" on page 181 in the Electrical section.

Engine Cranks But Does Not Start

Symptom: Engine Cranks But Does Not Start

(1) Are battery cables loose or dirty?

Yes - Tighten or clean.

No - Go to next step.

(2) Is battery fully charged?

No - Charge battery.

Yes - Go to next step.

(3) Have the operating conditions for the cranking and ignition systems been met? See "Cranking Circuit Operation" on page 138 and See "Ignition Circuit Operation" on page 142 in the Electrical section.

Yes - Go to next step.

No - Set the switches to the proper positions.

(4) Is air cleaner dirty?

Yes - Clean or replace. See "Air Cleaner Removal and Installation" on page 33.

No - Go to next step.

(5) Are spark plugs loose/dirty?

Yes - Clean or replace and tighten to specifications.

No - Go to next step.

(6) Is fuel old or contaminated?

Yes - Replace.

No - Go to next step.

(7) Are fuel filter/lines clogged?

Yes - Replace or clean.

No - Go to next step.

(8) Is fuel shutoff solenoid defective? See "Fuel Shutoff Solenoid Test" on page 29.

Yes - Replace.

No - Go to next step.

(9) Is fuel pump defective?

Yes - Replace.

No - Go to next step.

(10) Is ignition coil air gap adjusted properly? See "Ignition Armature Air Gap Adjustment" on page 32.

No - Adjust. See "Ignition Armature Air Gap Adjustment" on page 32.

ENGINE - BRIGGS AND STRATTON DIAGNOSTICS

Symptom: Engine Cranks But Does Not Start

Yes - Go to next step.

(11) Is carburetor adjusted properly, clean? See "Carburetor Adjustment" on page 28.

No - Adjust or clean. See "Carburetor Adjustment" on page 28.

Yes - Go to next step.

(12) Is magneto kill circuit grounded - shorted? See "Ignition Circuit Operation" on page 142 In the Electrical section.

Yes - Repair as needed.

No - Go to next step.

(13) Does engine lack compression? See "Compression Test" on page 30.

Yes - Check valves, pistons and rings.

No - Go to next step.

(14) Do valve tappets need adjustment? See "Valve Inspection and Repair" on page 47.

Yes - See "Valve Inspection and Repair" on page 47.

No - Go to next step.

(15) Are valves and/or valve seats burned or are valve seats loose? See "Valve Inspection and Repair" on page 47.

Yes - See "Valve Inspection and Repair" on page 47.

No - Go to next step.

(16) Has engine seized?

Yes - See "Engine Removal and Installation" on page 42.

No - Go to next step.

(17) Is camshaft worn?

Yes - See repair section.

Engine Starts Hard



CAUTION: Avoid Injury! Do not rotate engine with starting motor if the spark plugs are removed. Gasoline spray from the open cylinders may be ignited by ignition spark and cause an explosion or fire.

IMPORTANT: Avoid damage! Perform a visual inspection first to determine if battery cables are tight and not corroded and if the battery is of sufficient size to turn the engine over at minimum cranking speed of 350 rpm.

Symptom: Engine Starts Hard

(1) Are battery cables loose or dirty?

Yes - Tighten or clean.

No - Go to next step.

(2) Is battery fully charged? See "Battery Voltage & Specific Gravity Tests" on page 178 in the Electrical section.

No - Charge battery. See "Battery - Charge" on page 179 in the Electrical section.

Yes - Go to next step.

(3) Is air cleaner dirty?

Yes - Clean or replace. See "Air Cleaner Removal and Installation" on page 33.

No - Go to next step.

(4) Is fuel pump defective?

Yes - Replace.

No - Go to next step.

(5) Is ignition coil air gap adjusted properly? See "Ignition Armature Air Gap Adjustment" on page 32.

No - Adjust as needed.

Yes - Go to next step.

(6) Is carburetor adjusted properly, clean? See "Carburetor Adjustment" on page 28.

No - Adjust or clean.

Yes - Go to next step.

(7) Are spark plugs loose/dirty?

Yes - Clean or replace and tighten to specifications.

No - Go to next step.



Suggest:

If the above button click is invalid.

Please download this document

first, and then click the above link

to download the complete manual.

Thank you so much for reading

ENGINE - BRIGGS AND STRATTON DIAGNOSTICS

Symptom: Engine Starts Hard

(8) Is fuel old or contaminated?

Yes - Replace

No - Go to next step.

(9) Does engine lack compression? See "Compression Test" on page 30.

Yes - Check valves, pistons and rings.

No - Go to next step.

(10) Do valve tappets need adjustment? See "Valve Inspection and Repair" on page 47.

Yes - Adjust as needed.

No - Go to next step.

(11) Are valves and/or valve seats burned or are valve seats loose? See "Valve Inspection and Repair" on page 47.

Yes - Repair or replace valves and/or seats as needed.

No - Go to next step.

(12) Is cylinder head warped? See "Cylinder Head Inspection and Repair" on page 46.

Yes - Replace. See "Cylinder Head Removal and Installation" on page 44 and See "Cylinder Head Inspection and Repair" on page 46.

No - Go to next step.

(13) Is exhaust system restricted?

Yes - Clear exhaust system.

No - Go to next step.

(14) Is camshaft worn?

Yes - Replace.

No - Go to next step.

(15) Is connecting rod broken? See "Connecting Rod Inspection" on page 50.

Yes - See "Piston, Rings & Rod Removal and Installation" on page 48.

No - Go to next step.

(16) Are cylinder bore or rings worn? See "Piston, Rings & Rod Removal and Installation" on page 48 and See "Cylinder Bore Inspection" on page 52.

Yes - See "Piston, Rings & Rod Removal and Installation" on page 48 and See "Cylinder Bore Inspection" on page 52.

Engine won't shut off

Symptom: Engine won't shut off

(1) Is magneto kill circuit grounded - shorted? See "Ignition Circuit Operation" on page 142 in the Electrical section.

Yes - Repair as needed.

No - Go to next step.

(2) Is carburetor adjusted properly, clean? See "Carburetor Adjustment" on page 28.

No - Adjust or clean carburetor.

Yes - Go to next step.

(3) Is fuel shutoff solenoid defective? See "Fuel Shutoff Solenoid Test" on page 29.

Yes - Replace.

Loss of power

Symptom: Loss of power

(1) Is air cleaner dirty?

Yes - Clean or replace. See "Air Cleaner Removal and Installation" on page 33.

No - Go to next step.

(2) Are fuel filter/lines clogged?

Yes - Replace or clean

No - Go to next step.

(3) Is fuel pump defective?

Yes - Replace.

No - Go to next step.

(4) Is ignition coil air gap adjusted properly? See "Ignition Armature Air Gap Adjustment" on page 32.

No - Adjust as needed.

Yes - Go to next step.

(5) Are spark plugs loose/dirty?

Yes - Clean or replace and tighten to specifications.

No - Go to next step.

(6) Is fuel old or contaminated?

Yes - Replace fuel.

No - Go to next step.

(7) Is fuel shutoff solenoid defective? See "Fuel Shutoff Solenoid Test" on page 29.

<https://www.ebooklibonline.com>

Hello dear friend!

Thank you very much for reading.

Enter the link into your browser.

The full manual is available for immediate download.

<https://www.ebooklibonline.com>