

MODEL 70 STANDARD TRACTOR



JOHN DEERE

OPERATORS MANUAL MODEL 70 STANDARD TRACTOR

OMR2036 E6 English

OMR2036 E6

LITHO IN THE U.S.A.
ENGLISH



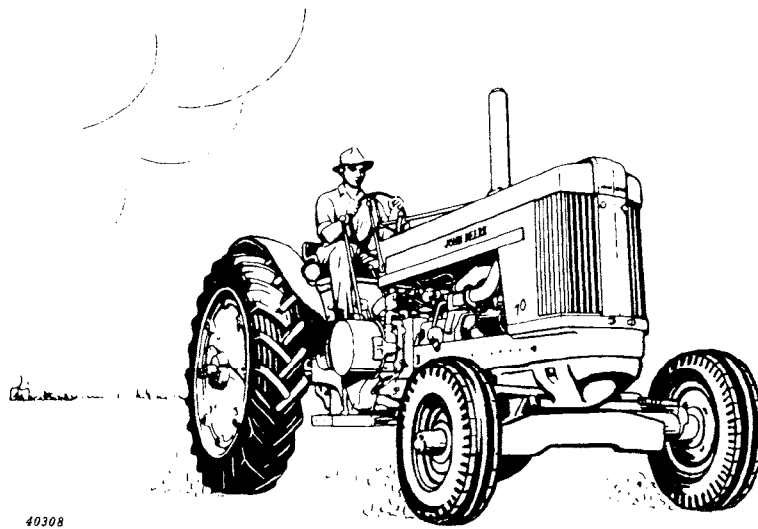

TO THE PURCHASER

We welcome you to our ever-growing family of John Deere tractor owners. We are confident that the dependable and economical performance of the John Deere Model "70" Standard Tractor will prove that you made a wise choice.

The purpose of this manual is to acquaint you with your new tractor. The manual explains how to operate and service your tractor, and how to maintain its high operating efficiency. Instructions are given clearly with the intention of making these operations as easy as possible.

Keep this manual in a convenient place for quick and easy reference. Use it as a guide whenever questions arise. You have purchased a dependable, sturdy tractor, but only by operating and caring for it properly can you expect to receive the service and long life for which it was designed.

If in the future you need new parts to replace those that may be worn, insist on genuine John Deere parts. They are exact duplicates of the originals, made from the same patterns and of the same high-quality materials.

When in need of parts, give your John Deere dealer the serial number of your tractor, distributor, or Powr-Trol, depending on the parts you need. The illustration below shows you where to find these serial numbers. Obtain them from your tractor—NOW—and insert them in the spaces provided in the illustrations below.

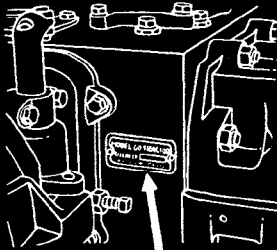
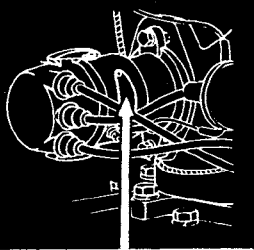
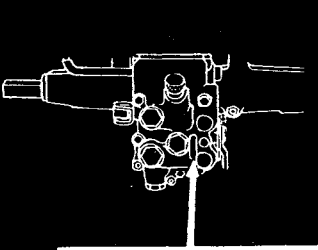
TRACTOR	DISTRIBUTOR	POWR-TROL
 <input data-bbox="320 1783 584 1839" type="text"/>	 <input data-bbox="683 1783 946 1839" type="text"/>	 <input data-bbox="1046 1783 1310 1839" type="text"/>
Owner <input data-bbox="400 1845 863 1877" type="text"/>		
35162 Date Purchased <input data-bbox="488 1883 783 1915" type="text"/>		

• TABLE OF CONTENTS •

	<i>Page</i>
SPECIFICATIONS AND DATA.....	5
CONTROLS AND INSTRUMENTS.....	7
OPERATING INSTRUCTIONS.....	21
SAFETY SUGGESTIONS.....	52
LUBRICATION AND PERIODIC SERVICES.....	55
SERVICE THAT WILL KEEP YOUR TRACTOR IN TIP-TOP SHAPE.....	75
SERVICE REMINDERS.....	102
TRACTOR DIFFICULTIES.....	103
STORING THE TRACTOR.....	109
INDEX.....	111



40309

<https://www.ebooklibonline.com>

Hello dear friend!

Thank you very much for reading.

Enter the link into your browser.

The full manual is available for immediate download.

<https://www.ebooklibonline.com>

Even though your dealer has carefully inspected this tractor before delivering it to you, it is always good business to re-check the items which are encircled on the reproduction below of the envelope which contains this manual.

TO THE NEW JOHN DEERE TRACTOR OWNER

Each John Deere Tractor is carefully designed, assembled, and given a complete test and final inspection at the factory before it is shipped. Our main ambition is to deliver tractors to new owners in the same mechanical condition as when shipped from the factory.

To enable us to fulfill this one ambition, this tractor was carefully inspected for irregularities that may have occurred in shipment. This inspection included a complete checking of the following:

- Wheel equipment: Tire pressure Wheel weights; Install calcium chloride if requested by new Date 5/1/54. Dealer Ernest Business Supply owner.
- Radiator: Fill with water or anti-freeze.
- Air cleaner oil level.
- Manifold heat control.
- Crankcase oil level.
- Transmission oil level.
- Steering housing oil level.
- Powr-Trol oil level.
- Power shaft clutch oil level.
- Grease tractor.
- Rear wheel brakes.
- Clutch operation.
- Spark plug gaps.
- Tighten cap screws and nuts.
- Carburetor setting. (May require adjusting later according to fuel burned.) (See Instructions in Manual.)
- Engine speed and oil pressure.
- Inspect rubber hose connections.
- Connect battery ground terminal. Check battery water level. Grease terminal posts.
- Check lights.
- Check starting motor for operation.
- Serial numbers entered in owner's register.

The above inspection made by John Doe

Date 5/1/54. Dealer Ernest Business Supply



HANG THIS BOOK IN A
HANDY PLACE

45282

We suggest this rechecking especially during freezing weather or when a period of time has elapsed between delivery and when you are ready to operate it. For complete starting information, see page 24.



We, your John Deere dealer, are mighty proud to add your name to our list of John Deere tractor owners. Because we are interested in having you obtain from this new tractor all the comfort and long life that are built into it, we are pleased to discuss the following important maintenance operations:

- Controls.
- Manifold Heat Control.
- Breaking-in Period—Part Load, Open Throttle, Changing Oil.
- Method of Starting and Stopping Engine.
- Lubrication—Engine, Transmission, Power Shaft Clutch, Powr-Trol, Grease Fittings, Air Cleaner and Oil Gauge.
- Cooling System—Adding Water, Thermostat, Cleaning.
- Fuel System—Fuel, Fuel Control, Sediment Bowl and Trap, Carburetor Adjustment.
- Tires—Inflation, Inspection, Wheel Weights.
- Drawbar—Adjustment; pull from no other place.
- Ignition System—Terminals Tight, Cleaning, Oiling, Adjusting Points.
- Battery Registration.
- Rear Wheel Brakes—Adjustment.
- Clutch—Adjustment, Pulley Brake.
- Front Wheels—Cleaning, Adjustment and Spacing.
- Powr-Trol—Drop Control, Operation.
- Power Shaft Clutch Adjustment and Operation.
- Starter and Lights—Starting, Lights, Battery Care.
- Tightening Cap Screws and Nuts.
- Safety in Operation—Selecting Proper Speed, Power Shaft.
- Keeping the Tractor Clean.
- Have Farmer Operate the Tractor.
- Appointment for After-Sales Service—not later than two weeks after delivery.

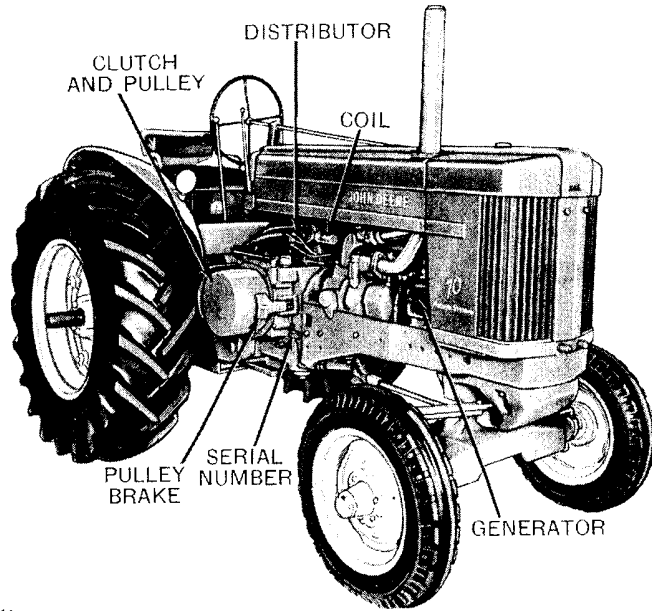

40310

John Deere Model "70" Standard Tractor with Adjustable-Tread Front Axle—Pulley Side

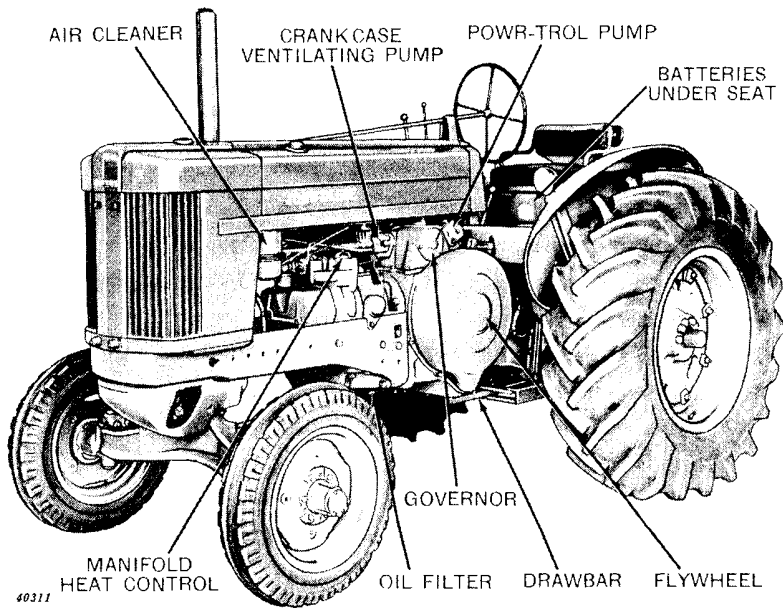

40311

John Deere Model "70" Standard Tractor with Fixed-Tread Front Axle—Flywheel Side

SPECIFICATIONS AND DATA . . .

PERFORMANCE:

Capacity for Work:

Four 14-inch plow bottoms in most soil conditions, five in many soils; and other big-capacity tools.

Maximum Belt Horsepower:

*Gasoline 50.35
*All-Fuel 44.96

Maximum Drawbar Horsepower:

*Gasoline 44.21
*All-Fuel 41.00

CAPACITIES (U. S. MEASUREMENTS):

Gasoline Tank:
Gasoline Tractor 24 Gals.
All-Fuel Tractor 1-3/4 Gals.
Fuel Tank (All-Fuel) 24 Gals.
Crankcase 11 Qts.
Transmission 7-1/2 Gals.
Powr-Trol 1-1/3 Gals.
Power Shaft Clutch 2-1/4 Qts.
Remote Cylinder 1 Qt.
Cooling System 8-1/2 Gals.
First Reduction Gear Cover 1-1/2 Qts.

SPEEDS:

Gear	15-30 Tires
1	2-1/2 mph
2	3-1/2 mph
3	4-1/2 mph
4	6-1/4 mph
5	8-1/2 mph
6	12 mph
Reverse	3-1/4 mph

ENGINE:

Type Two-cylinder, cast-in-block, valves-in-head.
Engine Speeds:
Load 975 rpm
Idle 1115 rpm
Bore and Stroke—Gasoline 5-7/8" x 7"
All-Fuel 6-1/8" x 7"
Displacement—Gasoline 379.5 cu. in.
All-Fuel 412.5 cu. in.
Compression Ratio:
Gasoline 6.1 to 1
All-Fuel 4.5 to 1

LUBRICATION SYSTEM:

Type Full force-feed pressure system with full flow oil filter.

FUEL SYSTEM:

Type Gravity feed
Carburetor Natural-draft duplex type
Air Cleaner Oil-wash type

COOLING SYSTEM:

Type Pressure system—centrifugal pump with engine temperature controlled by heavy-duty automotive-type thermostat.

IGNITION SYSTEM:

Type Battery-Distributor
Distributor Point Gap022"
Spark Plugs:
Size 18 mm.
Spark Plug Gap030"

ELECTRICAL SYSTEM:

Battery Voltage 12 Volts
Generator Regulation Voltage Regulator
Battery Group I

CLUTCH:

Type Hand-operated, 10-inch dry disks.

BELT PULLEY:

Diameter 12-7/8"
Width 7-3/8"
Rpm (Load) 975
Belt Speed 3285 fpm

TRANSMISSION:

Type Six forward speeds and one in reverse.
Gears Selective-type, straight spur-cut gears, forged and heat-treated.
Bearings Shafts operate on five roller bearings, six tapered roll bearings, and four ball bearings.

(Continued on next page)

*Maximum h.p. corrected to 60° F. and 29.92 in. hg. (Nebraska Tests Nos. 498 and 506)

CONTROLS

THE quality of work and the amount of work you do with your tractor not only depends upon the use of proper equipment, but also upon the ease and convenience of tractor operation. If you are in an uncomfortable position, if you have to fight the steering wheel, or if you can't see what you are doing, you are definitely handicapped.

Your John Deere Tractor is as convenient to handle as your automobile. All controls and levers are reached easily from the operator's seat. Under your feet are the convenient brakes and a large, comfortable platform on which you can stand if you so desire.

Familiarize yourself with all the controls provided for safe and easy operation of your new tractor. Regardless of your previous tractor experience, study this section covering controls carefully before you operate your tractor.

40312

70

STANDARD

STARTING CONTROLS

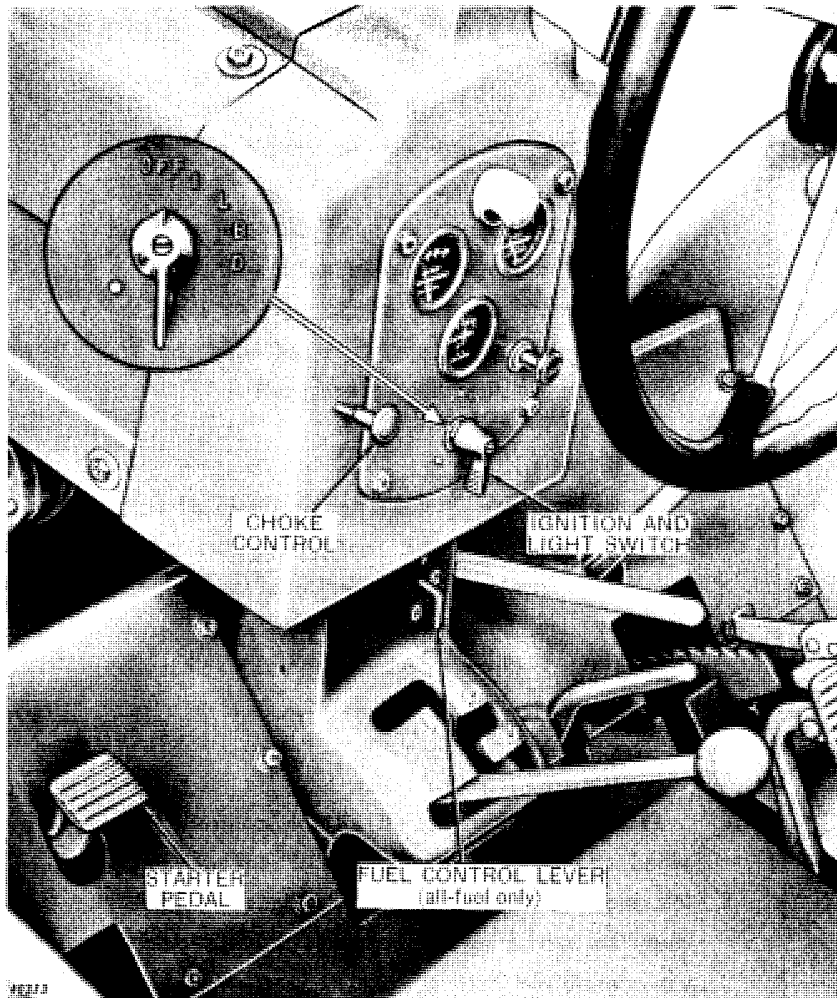

Starting Controls

IGNITION-LIGHT SWITCH.

The ignition on your new tractor is controlled by a combination ignition-light switch located in the center of the instrument panel. Turning the switch to any position except "OFF" turns on the ignition.

Your tractor is equipped with lights which are designed to provide maximum use and convenience both for night work in the field and night travel on the highway. The combination rear lamp has a bright white light for illuminating drawn implements and a red light for highway travel.

All lights are controlled by the combination ignition-light switch. The switch has five positions as follows:

- "OFF"—Both ignition and lights off
- "I" —Ignition only
- "L" —Bright front lights and white rear light
- "B" —Bright front lights and red rear light
- "D" —Dim front lights and red rear light

FUEL SHUT-OFF (GASOLINE TRACTORS).

Gasoline tractors are equipped with an automatic oil-pressure-operated fuel shut-off valve located on top of the fuel filter bowl. When the engine is stopped, the valve automatically shuts off flow of fuel to the filter. As soon as the engine is turned over by the starter the valve is automatically opened by engine oil pressure.

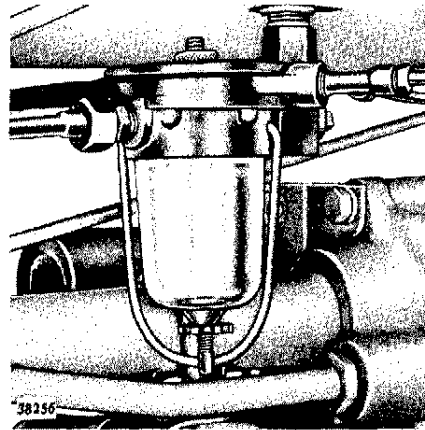

Fuel Filter with Automatic Shut-Off Valve

FUEL-CONTROL LEVER (ALL-FUEL TRACTORS).

A three-way fuel control lever on All-Fuel tractors enables the operator to switch from gasoline for starting the engine to low-cost fuel for operation, or to shut off the fuel supply entirely without leaving his position at the wheel.

STARTER PEDAL.

The engine is started by the pedal located in convenient reach of the operator's left foot. The pedal engages the starter pinion with the fly-wheel and also completes the electrical circuit to the starting motor. For starting instructions see page 27.

CHOKE CONTROL.

Pulling the choke button provides a rich mixture for the engine when starting. When button is pushed in, the choke returns to its normal position.

OPERATING CONTROLS

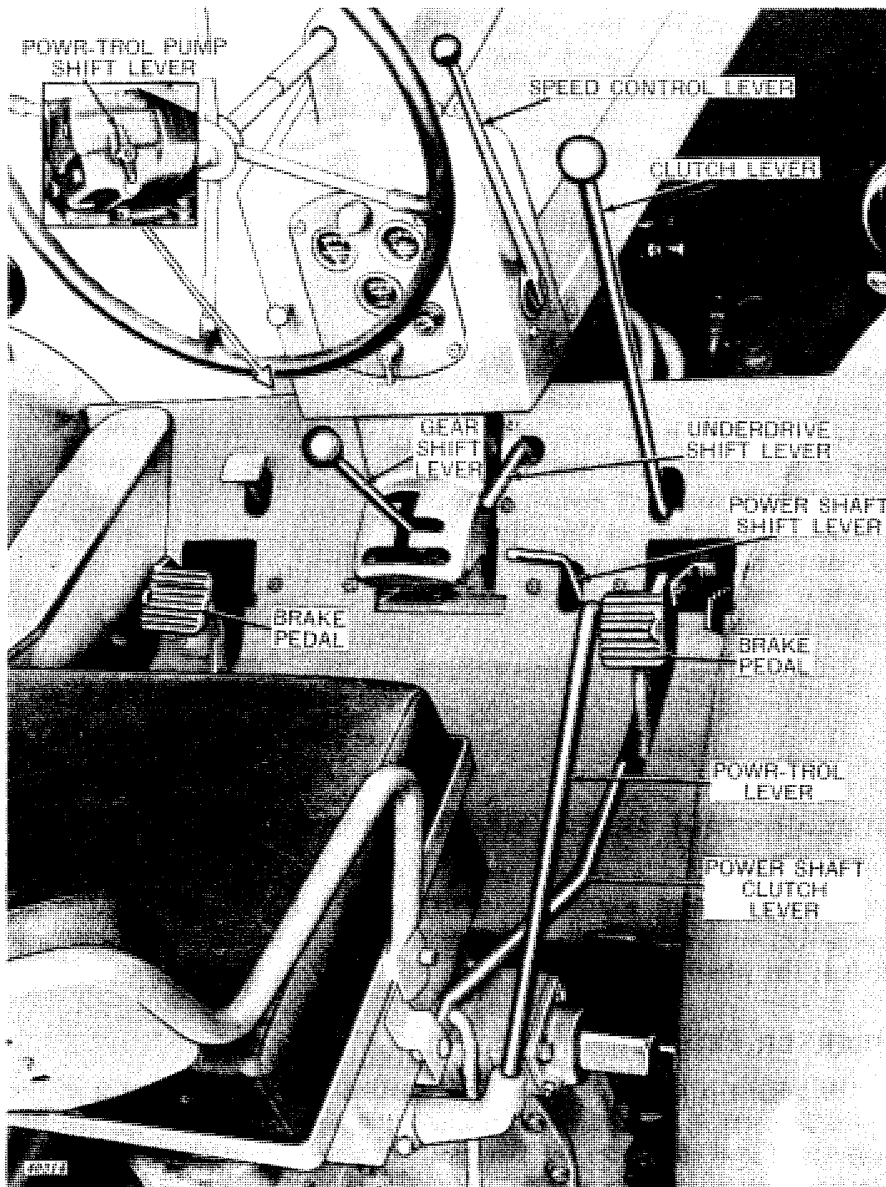

Operating Controls

SPEED CONTROL LEVER.

The lever mounted on the right-hand side of the hood support regulates the speed of the tractor engine. Pushing it forward opens the throttle and pulling it back closes the throttle. *NOTE: It is good practice to operate the engine whenever possible with speed control lever in forward position.*

CLUTCH LEVER AND PULLEY BRAKE.

Power required to put the tractor in motion is gradually and smoothly applied to the drive system by slowly pushing the clutch lever forward. When the tractor picks up speed, a quick forward thrust on the lever snaps the clutch into engagement.

By pulling back on the clutch lever, the clutch is released and engine disconnected from the transmission.

The pulley brake, which is applied when the clutch lever is pulled back to disengage the clutch, stops the pulley from rotating, permitting easy shifting of the transmission gears. *NOTE: Do not use pulley brake to stop tractor.*

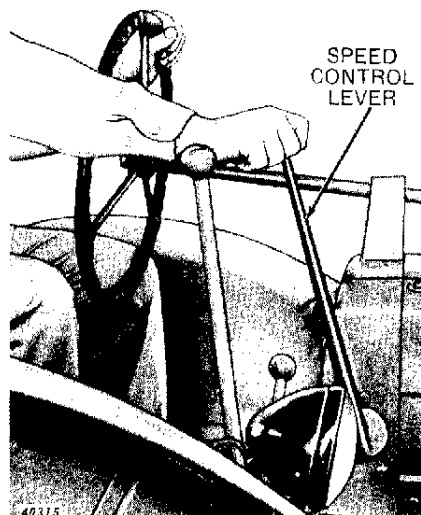

Speed Control Lever

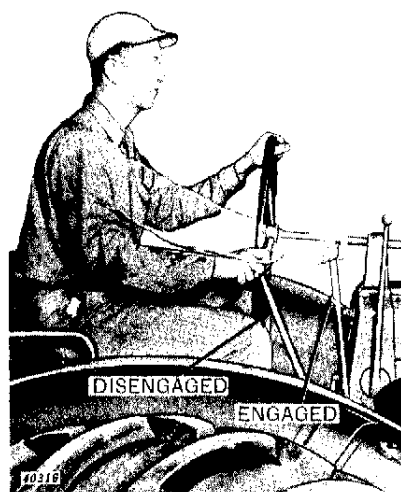

Clutch Lever and Pulley Brake

GEAR SHIFT LEVERS.

Familiarize yourself with the shifting diagrams before you attempt to operate the tractor.

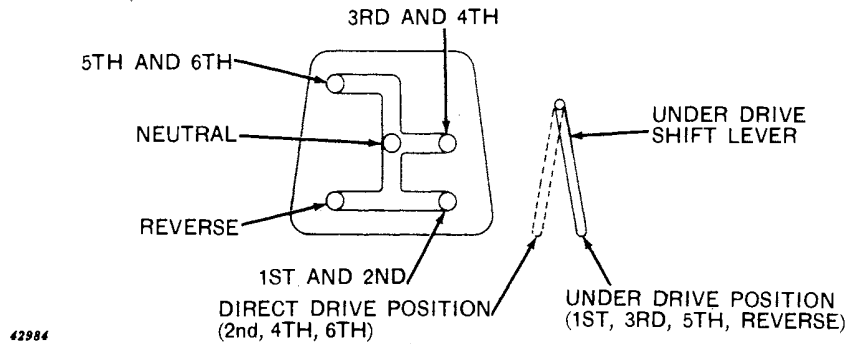

Gear Shift and Underdrive Lever Positions

When the underdrive shift lever is moved to the right, first, third, fifth and reverse speeds are obtained by moving the gear shift lever to the proper position as shown on the chart above. When the underdrive shift lever is moved to the left, second, fourth, and sixth speeds are obtained by moving the gear shift lever to the proper position.

If gears do not shift freely, move clutch lever forward until pulley turns slowly. This allows gear teeth to line up for shifting.

Avoid clashing of gears. This causes unnecessary wear and possible breakage.

BRAKES.

Individually foot-operated brakes make possible short turns to right or left.

To assure safe stopping at high transport speeds, apply the brakes evenly to avoid drawing the tractor to one side.

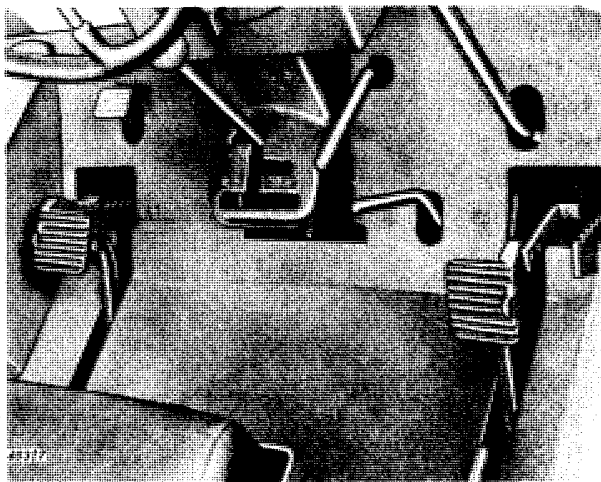

Brake Pedals and Latches

A brake latch is conveniently located for locking each brake when doing belt work or when holding the tractor on a hill or incline. The brakes are locked by tipping the top of the pedal forward to engage the latch. The brakes are released by pressing on the heel of the pedals.

SEAT AND BATTERY COMPARTMENT.

The large, roomy seat adds much to operator comfort and materially lessens fatigue.

A stop pin and adjusting lever, located on the right-hand side of the seat, make it possible to move the seat forward and backward to suit the convenience of the operator.

The back of the seat can be adjusted for height by removing the attaching screws shown in the illustration and raising or lowering the back to suit the operator.

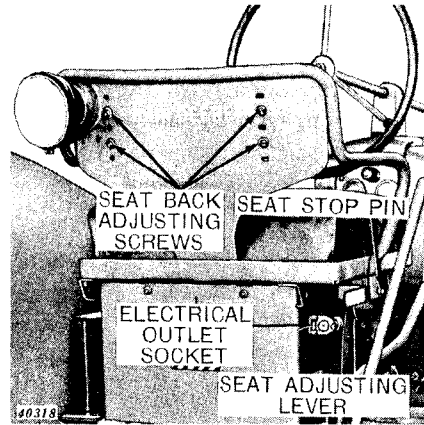

Seat

The batteries are located in a compartment under the seat where they are readily accessible for periodic checking and service.

An electrical outlet socket is located on the right-hand side of the battery box. This socket is provided for you to attach your battery charger, trouble light or lights on your trailing implements.

STEERING MECHANISM.

The seat location and streamlined hood design permit easy view of work on either side or at the rear. This design, coupled with a steering mechanism built to eliminate objectionable wandering, backlash, or whipping of the steering wheel permits you to work in freedom and comfort.

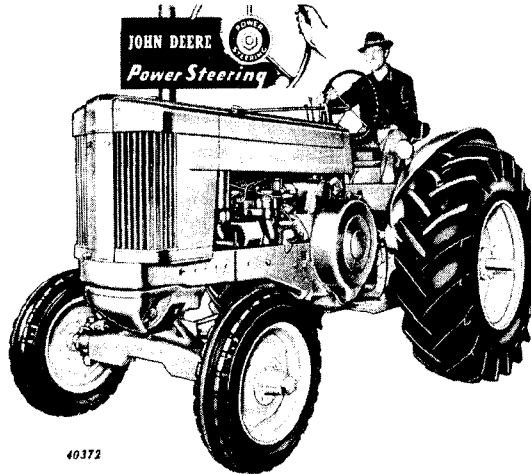

Steering a Model "70" Tractor

If your tractor is equipped with exclusive John Deere Power Steering you will be able to steer without effort in the roughest going. Even such adverse conditions as deep sand or heavy front-end-mounted equipment will not affect the ease with which you turn the steering wheel.

POWER SHAFT SHIFT LEVER.

Your new tractor may be equipped with either a transmission-driven power shaft, or an engine-driven (constant-running) power shaft which runs independently of the tractor transmission. In either case the power shaft is engaged by the power shaft shift lever located to the right of the gear shift lever.

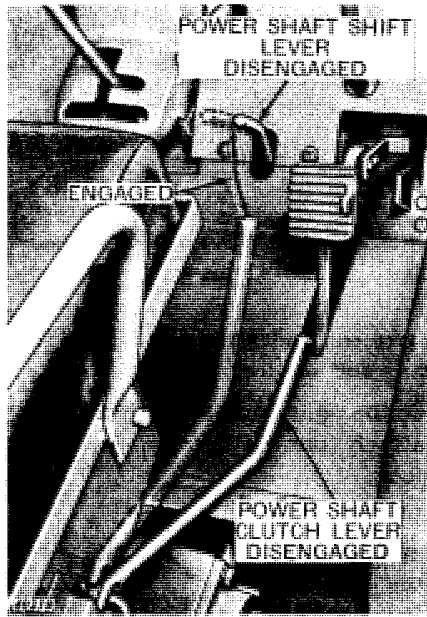

Power Shaft Shift Lever and Clutch Lever

Move the lever to the left to engage the power shaft and to the right to disengage the shaft. **CAUTION: Do not engage the power shaft shift lever while the engine is running. Before engaging the lever, read the operating instructions on page 40.**

POWER SHAFT CLUTCH LEVER.

A power shaft clutch is provided on tractors equipped with an engine-driven power shaft. The clutch makes it easy and convenient to use the power shaft without the necessity of shifting gears. Pulling up the clutch lever engages the clutch; pushing the lever down disengages the clutch and applies a partial brake to power shaft. Additional downward pressure on the lever brings in added brake action and effects a faster stopping of the power shaft.

POWER SHAFT MASTER SAFETY SHIELD.

A master safety shield is mounted over the power shaft to provide for the safety of the operator. This master shield should be removed only when it is necessary to mount integral equipment where the power shaft is used. *Replace the master shield immediately upon removal of the equipment.*

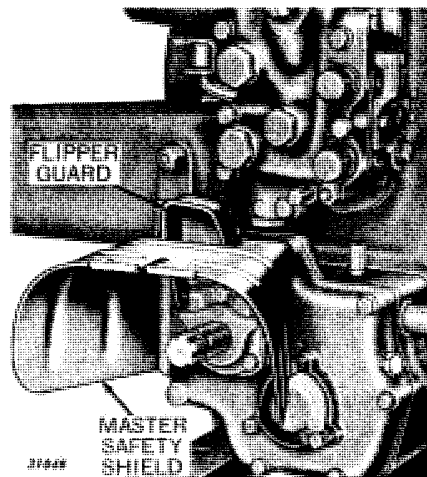

Power Shaft Master Safety Shield and Flipper Guard

POWER SHAFT FLIPPER GUARD.

The power shaft flipper guard should never be removed from the tractor. Do not operate the tractor with the end of the power shaft



Suggest:

If the above button click is invalid.

Please download this document

first, and then click the above link

to download the complete manual.

Thank you so much for reading

exposed. If the flipper is damaged, repair or replace it immediately.

Make it a rule never to dismount from the tractor without first disengaging the power shaft.

POWR-TROL PUMP CONTROL.

The Powr-Trol pump is engaged by a control lever located below and to the left of the instrument panel. The pump is engaged by rotating control lever in a counterclockwise direction and disengaged by turning the lever in a clockwise direction.

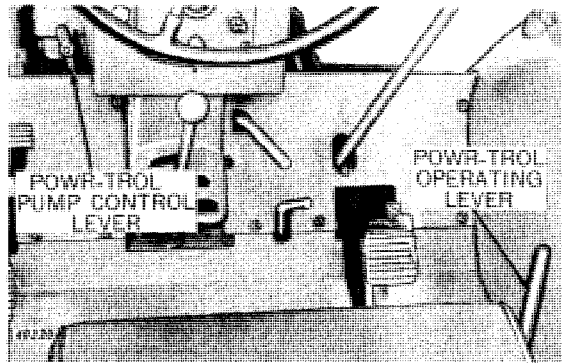

Powr-Trol Pump Control Lever and Powr-Trol Operating Lever

CAUTION: Do not engage the Powr-Trol pump while the engine is running. It may be necessary to turn the engine over by means of the starter with the ignition switch off to engage the gears.

POWR-TROL OPERATING LEVER.

The lever at the side of the seat operates the Powr-Trol. The lever has five operating positions; neutral, slow raise, fast raise, slow drop, and fast drop. Implements are raised by pushing the lever forward and dropped by pushing the lever to the rear. For further information, see page 43.

REAR WHEEL TREAD ADJUSTING PINION.

The rear wheels on your new tractor can be easily adjusted for tread width by loosening the hub bolts and turning the pinion shaft shown in the illustration to the right. Turning the pinion causes the wheel to move in or out on the axle. See page 34 for additional information.

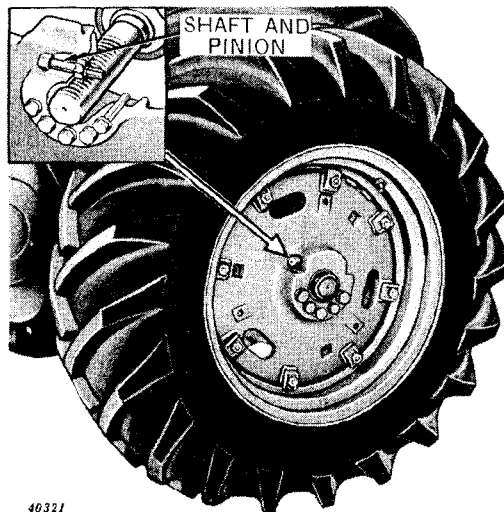

46321

Rear Wheel Adjusting Shaft and Pinion

<https://www.ebooklibonline.com>

Hello dear friend!

Thank you very much for reading.

Enter the link into your browser.

The full manual is available for immediate download.

<https://www.ebooklibonline.com>